



**THE DATASHEET OF  
RT4533AGJ6**



## Asynchronous Boost Converter for 10 WLEDs

### General Description

The RT4533/A is a highly integrated LED driver IC capable of driving 10 WLEDs in series. It is composed of a current mode Boost converter integrated with a 36.5V/1.2A power switch.

The RT4533/A supports a wide input voltage range from 2.5V to 5.5V and runs at a fixed frequency of 1.1MHz. The LED current is set via an external resistor and the feedback voltage is regulated to 200mV / 300mV.

For brightness dimming, the RT4533/A supports PWM dimming which determines the feedback reference voltage.

### Applications

- Cellular Phones
- Digital Cameras
- Probable Instruments

### Marking Information

RT4533GJ6

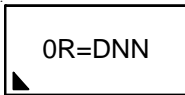

0R= : Product Code  
DNN : Date Code

RT4533AGJ6

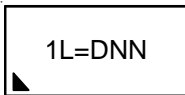

1L= : Product Code  
DNN : Date Code

### Features

- 2.5V to 5.5V Input Voltage Range
- 36.5V Open LED Protection for 10 WLEDs
- PWM Dimming Brightness Control
- 200mV / 300mV Reference Voltage with  $\pm 2\%$  Accuracy
- 1.1MHz Switching Frequency
- Built-In Soft-Start
- Over-Temperature Protection
- Internal Compensation
- Current Limit
- RoHS Compliant and Halogen Free

### Ordering Information

RT4533/A □ □

- Package Type  
J6 : TSOT-23-6
- Lead Plating System  
G : Green (Halogen Free and Pb Free)
- Feedback Voltage  
RT4533 : 200mV  
RT4533A : 300mV

Note :

Richtek products are :

- ▶ RoHS compliant and compatible with the current requirements of IPC/JEDEC J-STD-020.
- ▶ Suitable for use in SnPb or Pb-free soldering processes.

### Simplified Application Circuit

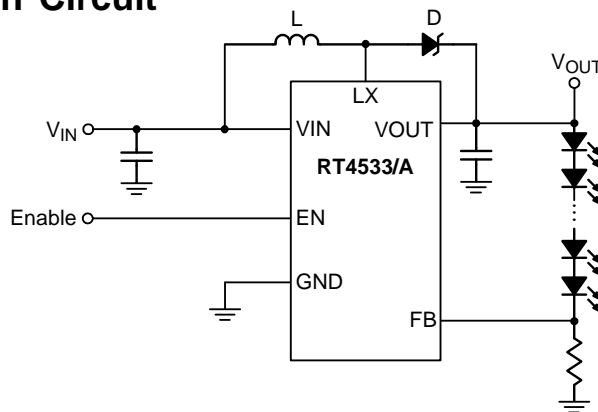

## Pin Configurations

(TOP VIEW)

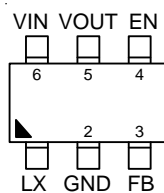

TSOT-23-6

## Functional Pin Description

Pin No.	Pin Name	Pin Function
1	LX	Switch Node.
2	GND	Ground.
3	FB	Feedback Voltage Input. Put a resistor to GND to setting the current.
4	EN	Enable Control Input (PWM Dimming).
5	VOUT	Output Voltage Pin.
6	VIN	Supply Voltage Input.

**Function Block Diagram**

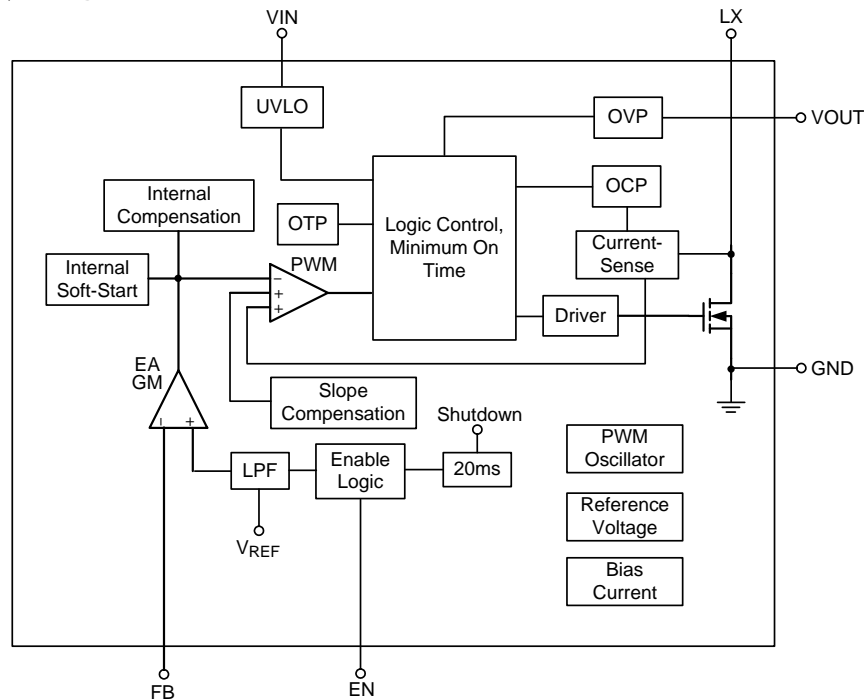

**Operation**

The RT4533/A is a constant frequency, current mode Boost LED driver. In normal operation, the N-MOSFET is turned on when the PWM Control circuit is set by the oscillator and is turned off when the current comparator resets the PWM Control circuit. While the N-MOSFET is turned off, the inductor current conducts through the external diode.

**UVLO**

When the input voltage is lower than the UVLO threshold (2.37V typ.), the driver will turn off. There is a 80mV for the UVLO hysteresis control.

**Soft-Start**

When the device is enabled, the Comp ramps up to the target voltage in a specific time. This ensures that the output voltage rises slowly to reduce the input inrush current.

**EN Dimming**

The EN pin is used for the control input for both PWM dimming mode and digital dimming mode. Shutdown delay when the EN voltage is logic low for more than specific time, the driver will be shut down.

**OCP**

The driver provides cycle-by-cycle current limit function to control the current on power switch. The boost switch turns off when the inductor current reaches this current threshold and it remains off until the beginning of the next switching cycle. This protects the RT4533/A and external component under overload conditions.

**OVP**

The Over Voltage Protection is detected by a resistor divider circuit from VOUT.

Once VOUT goes over the OVP voltage, LX pin stops switching and the power N-MOSFET will be turned off. Then, the VOUT will be discharged by external resistor. OVP will be released until EN goes from Lo to Hi again.

**OTP**

As the die temperature is higher than 160°C, the chip also will enter protection mode. The power MOSFET will be turned off during protection mode to prevent abnormal operation. The device is released from shutdown automatically when the junction temperature decreases by 15°C.

## Absolute Maximum Ratings (Note 1)

- VIN ----- -0.3V to 6V
- EN, FB to GND ----- -0.3V to (VIN + 0.3V)
- LX to GND ----- -0.3V to 38V
- VOUT to GND ----- -0.3V to 40V
- Power Dissipation, PD @ TA = 25°C  
 TSOT-23-6 ----- 0.5W
- Package Thermal Resistance (Note 2)  
 TSOT-23-6,  $\theta_{JA}$  ----- 197.4°C/W
- Junction Temperature ----- 150°C
- Lead Temperature (Soldering, 10 sec.) ----- 260°C
- Storage Temperature Range ----- -65°C to 150°C
- ESD Susceptibility (Note 3)  
 HBM (Human Body Model) ----- 2kV  
 MM (Machine Model) ----- 200V

## Recommended Operating Conditions (Note 4)

- Supply Input Voltage, VIN ----- 2.5V to 5.5V
- Junction Temperature Range ----- -40°C to 125°C
- Ambient Temperature Range ----- -40°C to 85°C

## Electrical Characteristics

(VIN = 3.6V, CIN = 4.7μF, COUT = 1μF, L = 22μH, fSW = 1.1MHz, TA = 25°C, unless otherwise specified)

Parameter	Symbol	Test Conditions	Min	Typ	Max	Unit
<b>Power Supply</b>						
IC Operating Current (switching)	IQ_SW	VFB = 0V	0.25	0.8	1.5	mA
IC Quiescent Current (non-switching)	IQ	VFB = 0.4V	0.25	0.35	0.5	mA
VIN Pin Shutdown Current	ISD	EN = GND	--	0.3	1	μA
Under-Voltage Lockout Threshold,	UVLO	VIN Rising Edge	2.25	2.37	2.5	V
Under-Voltage Lockout Hysteresis	UVLO_hys	VIN Falling Edge	--	80	--	mV
<b>Enable and Reference Control</b>						
EN Input Voltage	Logic-High	VIH	1.4	--	--	V
	Logic-Low	VIL	--	--	0.4	
EN Pull Low Resistance	REN		--	300	--	kΩ
EN Minimum Shut down Pulse Width	Toff		20	--	--	ms
EN Minimum Logic High Pulse Width	THigh_Min		0.5	--	--	μs
EN Minimum logic low pulse width	TLow		1	--	10000	μs
Internal Comp Resistance	Rcomp		--	7	--	MΩ
PWM Minimum Duty	Dpwm min		--	3	--	%
PWM Frequency	fPWM		5	--	100	kHz

Parameter	Symbol	Test Conditions	Min	Typ	Max	Unit
<b>Voltage And Current Control</b>						
Feedback Regulation Voltage	RT4533	$V_{FB}$	196	200	204	mV
	RT4533A		294	300	306	
Feedback Pin Bias Current	$I_{FB}$		--	--	0.1	$\mu A$
Oscillator Frequency	$f_{SW}$		0.99	1.1	1.21	MHz
Maximum Duty Cycle	$D_{MAX}$		--	93	--	%
<b>Power Switch</b>						
N-MOSFET On-Resistance	$R_{DS(ON)}$	$V_{IN} = 3.6V$	--	0.4	0.7	$\Omega$
<b>OC and OLP</b>						
Peak N-MOSFET Current Limit	$I_{LIM}$		1.0	1.2	1.4	A
Open LED Protection Threshold	OVP		35	36.5	38	V
<b>Thermal Shutdown</b>						
Thermal Shutdown Threshold	$T_{SD}$		--	160	--	$^{\circ}C$
Thermal Shutdown Hysteresis	$\Delta T_{SD}$		--	15	--	$^{\circ}C$

**Note 1.** Stresses beyond those listed “Absolute Maximum Ratings” may cause permanent damage to the device. These are stress ratings only, and functional operation of the device at these or any other conditions beyond those indicated in the operational sections of the specifications is not implied. Exposure to absolute maximum rating conditions may affect device reliability.

**Note 2.**  $\theta_{JA}$  is measured at  $T_A = 25^{\circ}C$  on a high effective thermal conductivity four-layer test board per JEDEC 51-7.

**Note 3.** Devices are ESD sensitive. Handling precaution is recommended.

**Note 4.** The device is not guaranteed to function outside its operating conditions.

## Typical Application Circuit

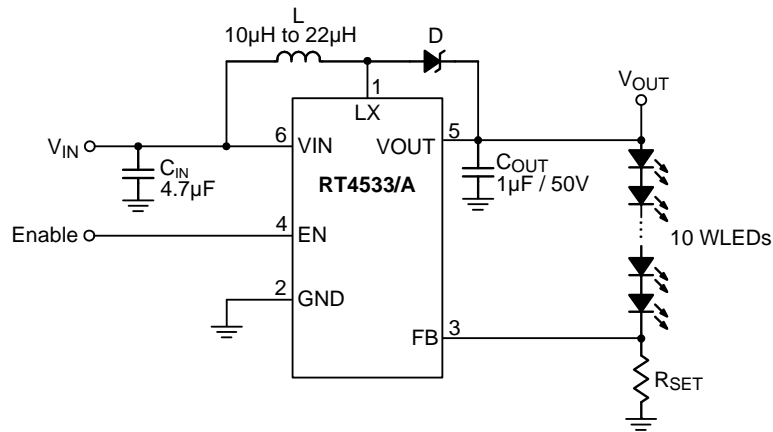

## Timing Diagram

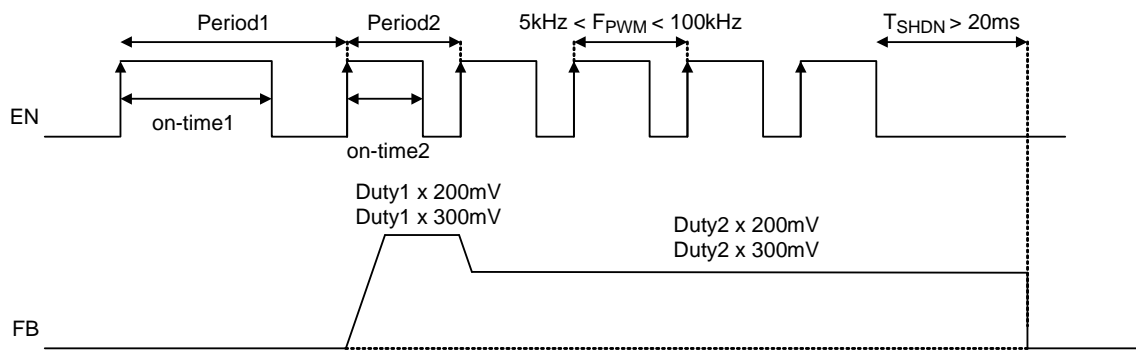

Duty1 : on-time1/Period1  
 Duty2 : on-time2/Period2

**Typical Operating Characteristics**

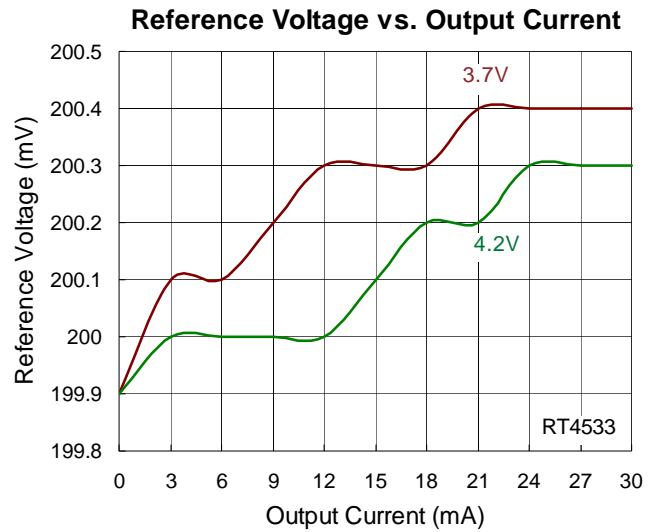
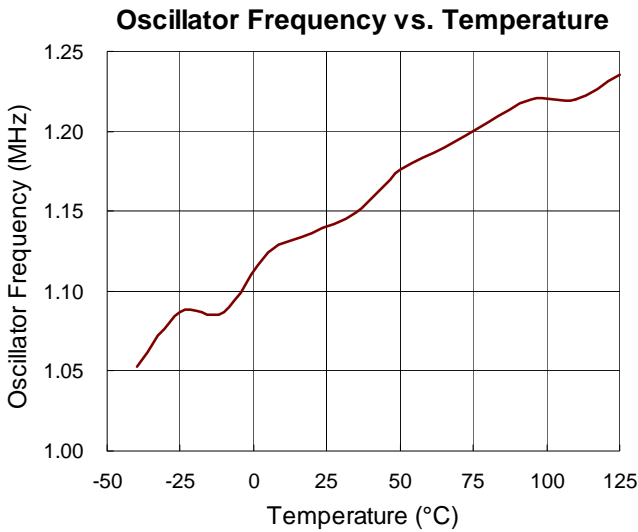
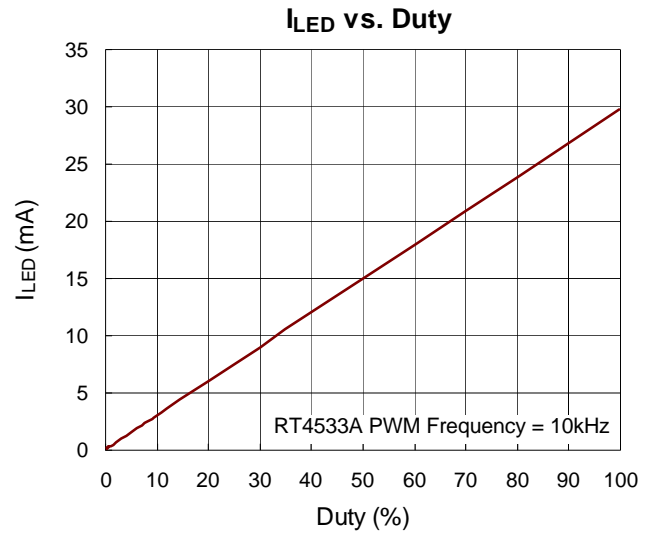
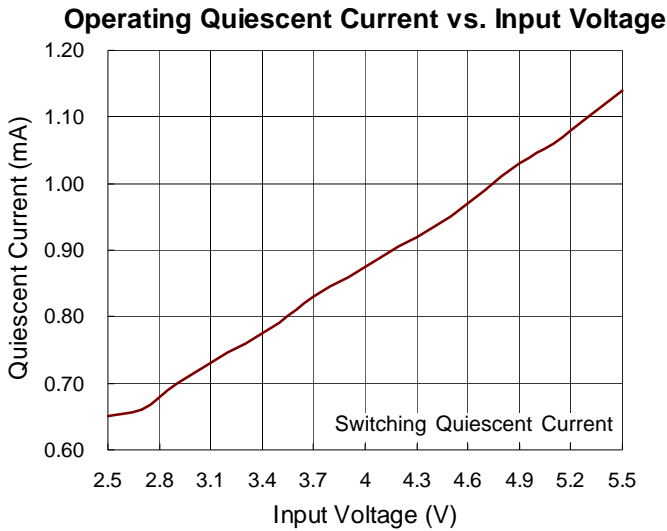
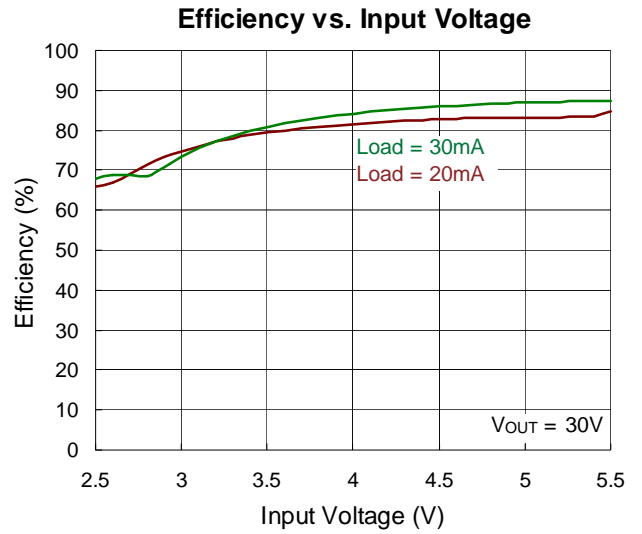
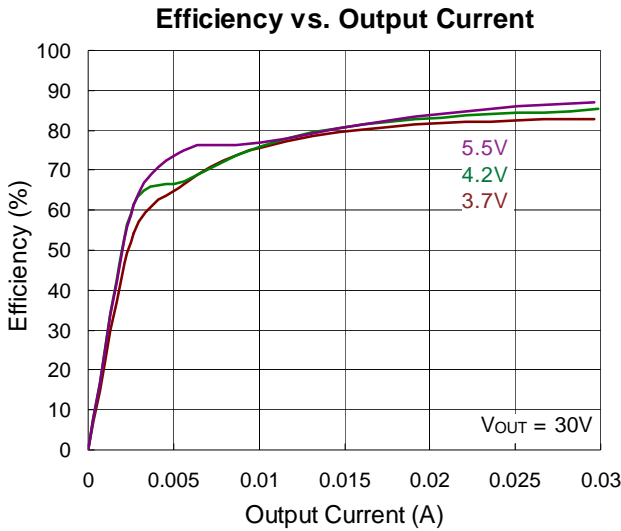

## Application Information

### Soft-Start

The RT4533/A includes a soft-start function to avoid high inrush current during start-up. The soft-start function is achieved by clamping the output voltage of the error amplifier with another voltage source that is increased slowly from zero to near VIN.

### LED Current

The loop control of the Boost converter keeps VFB equal to a reference voltage, VREF. Therefore, when RSET is connected between the FB pin and GND, the LED current will be determined by the current through RSET, which is equal to VFB / RSET.

### Current Limit

The current flowing through the inductor during a charging period is detected by a current sensing circuit. If the value exceeds the current limit, the N-MOSFET will be turned off. The inductor will then be forced to leave charging stage and enter discharging stage. Therefore, the inductor current will not increase to reach current limit.

### Shutdown Delay

When the EN voltage is in logic low for 20ms during PWM dimming, the system will enter shutdown.

### PWM Dimming

When the EN pin is constantly high, the FB voltage is regulated to 200mV / 300mV typically. The RT4533/A allows a PWM signal from EN pin to reduce the regulation voltage; and achieve LED brightness dimming. The relationship between the duty cycle and FB voltage is given by

$$V_{FB} = \text{Duty} \times V_{REF}$$

Where

Duty = duty cycle of the PWM signal VREF = internal reference voltage (200mV / 300mV typ.)

The RT4533/A choose the internal 200mV reference voltage via the duty cycle of the PWM signal. Therefore, although a PWM signal is used for brightness dimming, only the LED DC current is modulated, which is often referred as

analog dimming. This eliminates the audible noise which often occurs when the LED current is pulsed in replica of the frequency and duty cycle of PWM control. For optimum performance, use the PWM dimming frequency in the range of 5kHz to 100kHz, and the PWM dimming frequency is strongly suggested to be over than 20kHz to avoid audio noise.

### Inductor Selection

The recommended value of inductor for 10 LEDs or high brightness LED applications is 10μH to 22μH. Smaller size and better efficiency are the major concerns for portable devices. The inductor should have low core loss at 1MHz and low DCR for better efficiency. The inductor saturation current rating should be considered to cover the inductor peak current. Table 1 lists the recommended inductor for the RT4533/A.

Table 1

Part Number	L (μH)	DCR MAX (mΩ)	Saturation Current (A)	Size (L x W x H mm)	Vendor
NR4018T100M	10	216	1.2	4 x 4 x 1.8	TAIYO
NR4018T220M	22	432	0.8	4 x 4 x 1.8	TAIYO

### Capacitor Selection

For low ripple voltage, ceramic capacitors with low ESR are recommended. X5R and X7R types are suitable because of their wide voltage range and good operating temperature characteristics. For the application of the RT4533/A to drive 10 LEDs in series, a 4.7μF for input capacitor, an 1μF / 50V for output capacitor.

### Thermal Considerations

For continuous operation, do not exceed absolute maximum operation junction temperature. The maximum power dissipation depends on the thermal resistance of IC package, PCB layout, the rate of surroundings airflow and temperature difference between junction to ambient. The maximum power dissipation can be calculated by following formula :

$$P_{D(MAX)} = (T_{J(MAX)} - T_A) / \theta_{JA}$$

Where  $T_{J(MAX)}$  is the maximum operation junction temperature,  $T_A$  is the ambient temperature and the  $\theta_{JA}$  is the junction to ambient thermal resistance.

For recommended operating condition specifications, the maximum junction temperature is 125°C. The junction to ambient thermal resistance,  $\theta_{JA}$ , is layout dependent. For TSOT-23-6 package, the thermal resistance,  $\theta_{JA}$ , is 197.4°C/W on the standard JEDEC 51-7 four-layer thermal test board. The maximum power dissipation at  $T_A = 25^\circ\text{C}$  can be calculated by following formula :

$$P_{D(MAX)} = (125^\circ\text{C} - 25^\circ\text{C}) / (197.4^\circ\text{C/W}) = 0.5\text{W for TSOT-23-6 package}$$

The maximum power dissipation depends on operating ambient temperature for fixed  $T_{J(MAX)}$  and thermal resistance  $\theta_{JA}$ . The derating curve in Figure 1 of derating curves allows the designer to see the effect of rising ambient temperature on the maximum power allowed.

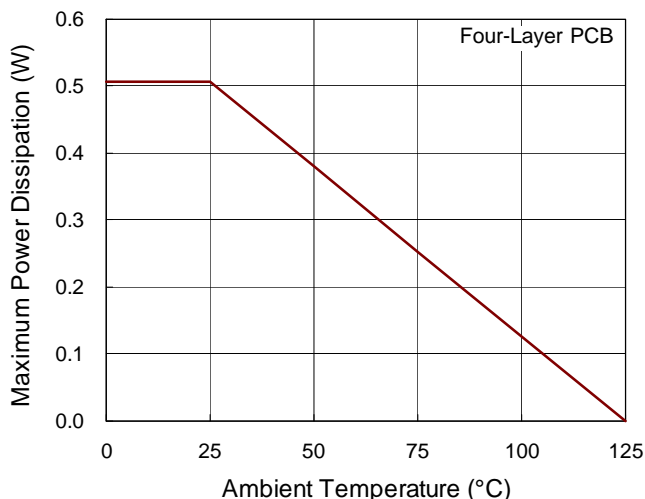

Figure 1. Derating Curve of Maximum Power Dissipation

**Layout Consideration**

For best performance of the RT4533/A, the following guide lines must be strictly followed.

- ▶ Input and Output capacitors should be placed close to the IC and connected to ground plane to reduce noise coupling.
- ▶ The GND and Exposed Pad should be connected to a strong ground plane for heat sinking and noise protection.
- ▶ Keep the main current traces as possible as short and wide.
- ▶ LX node of DC/DC converter is with high frequency voltage swing. It should be kept at a small area.
- ▶ Place the feedback components as close as possible to the IC and keep away from the noisy devices.

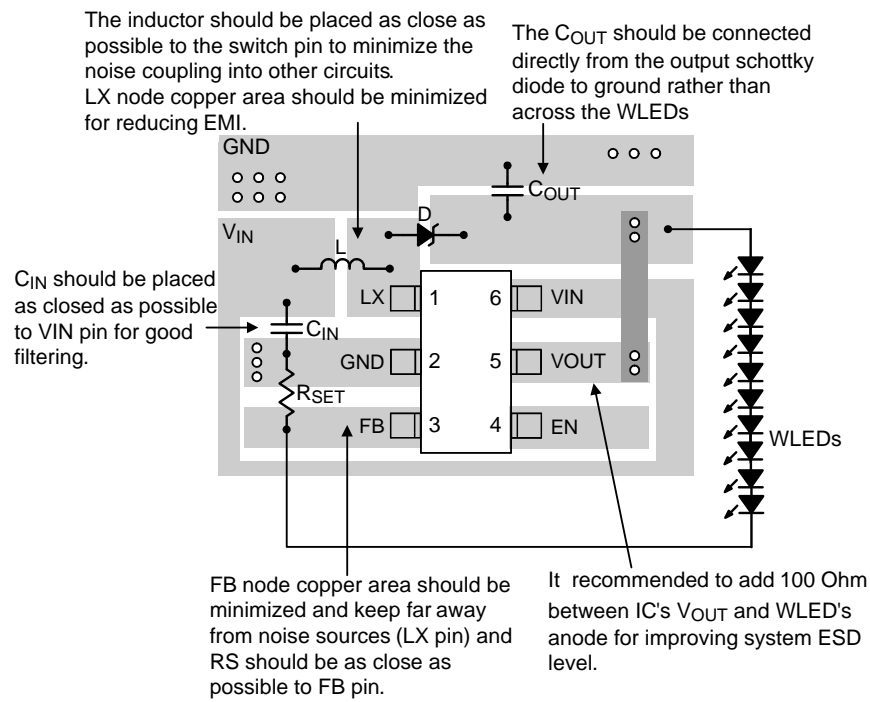
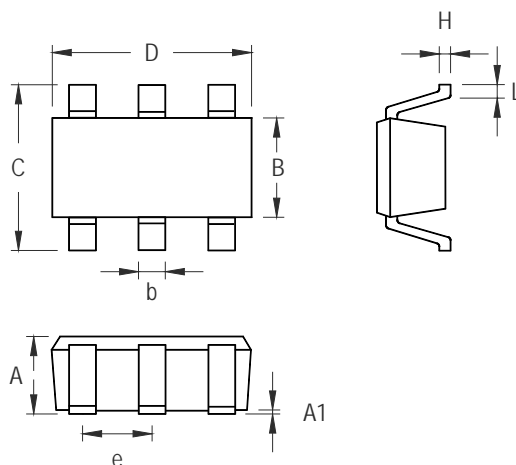

Figure 2. PCB Layout Guide

**Outline Dimension**



Symbol	Dimensions In Millimeters		Dimensions In Inches	
	Min	Max	Min	Max
A	0.700	1.000	0.028	0.039
A1	0.000	0.100	0.000	0.004
B	1.397	1.803	0.055	0.071
b	0.300	0.559	0.012	0.022
C	2.591	3.000	0.102	0.118
D	2.692	3.099	0.106	0.122
e	0.838	1.041	0.033	0.041
H	0.080	0.254	0.003	0.010
L	0.300	0.610	0.012	0.024

**TSOT-23-6 Surface Mount Package**

**Richtek Technology Corporation**

14F, No. 8, Tai Yuen 1<sup>st</sup> Street, Chupei City



Hsinchu, Taiwan, R.O.C.

Tel: (8863)5526789

Richtek products are sold by description only. Richtek reserves the right to change the circuitry and/or specifications without notice at any time. Customers should obtain the latest relevant information and data sheets before placing orders and should verify that such information is current and complete. Richtek cannot assume responsibility for use of any circuitry other than circuitry entirely embodied in a Richtek product. Information furnished by Richtek is believed to be accurate and reliable. However, no responsibility is assumed by Richtek or its subsidiaries for its use; nor for any infringements of patents or other rights of third parties which may result from its use. No license is granted by implication or otherwise under any patent or patent rights of Richtek or its subsidiaries.

## Looking for pricing, stock, or lifecycle information?

Click below to explore more details on WIN SOURCE:

-  [View RT4533AGJ6 on WIN SOURCE](#)
-  [Richtek USA Inc. Information](#)

## Optimize Your Supply Chain with WIN SOURCE Solutions

-  Global Sourcing Solution
-  Obsolete Management
-  Cost Control Management
-  Shortage Management
-  Alternative Solution
-  Excess Inventory Management