



# THE DATASHEET OF SMA4038



# SMA4038

NPN Darlington

With built-in flywheel diode

External dimensions ..... SMA (15-pin)

## Absolute maximum ratings

(Ta=25°C)

Symbol	Ratings	Unit
V <sub>CB0</sub>	120	V
V <sub>CEO</sub>	120	V
V <sub>EBO</sub>	6	V
I <sub>C</sub>	3	A
I <sub>CP</sub>	5 (PW≤1ms, Du≤50%)	A
I <sub>B</sub>	0.2	A
I <sub>F</sub>	3 (PW≤0.5ms, Du≤25%)	A
I <sub>FSM</sub>	5 (PW≤10ms, Single pulse)	A
V <sub>R</sub>	120	V
P <sub>T</sub>	4 (Ta=25°C) 20 (Tc=25°C)	W
T <sub>J</sub>	150	°C
T <sub>stg</sub>	-40 to +150	°C

## Electrical characteristics

(Ta=25°C)

Symbol	Specification			Unit	Conditions
	min	typ	max		
I <sub>CB0</sub>			10	μA	V <sub>CB</sub> =120V
I <sub>EBO</sub>			10	mA	V <sub>EB</sub> =6V
V <sub>CEO</sub>	120			V	I <sub>C</sub> =25mA
V <sub>CEO(SUS)</sub>	120			V	I <sub>C</sub> =1.5A
h <sub>FE</sub>	2000	5000	1500		V <sub>CE</sub> =4V, I <sub>C</sub> =1.5A
V <sub>CE(sat)</sub>		1.1	1.5	V	I <sub>C</sub> =1.5A, I <sub>B</sub> =3mA
V <sub>BE(sat)</sub>		1.7	2.0	V	
V <sub>FEC</sub>		1.4		V	I <sub>FEC</sub> =1.5A
t <sub>on</sub>		0.5		μs	V <sub>CC</sub> ≈30V, I <sub>C</sub> =1.5A,
t <sub>stg</sub>		2.4		μs	I <sub>B1</sub> =-I <sub>B2</sub> =3mA
t <sub>f</sub>		1.0		μs	V <sub>CB</sub> =10V, f=1MHz
C <sub>ob</sub>		30		pF	

## Equivalent circuit diagram

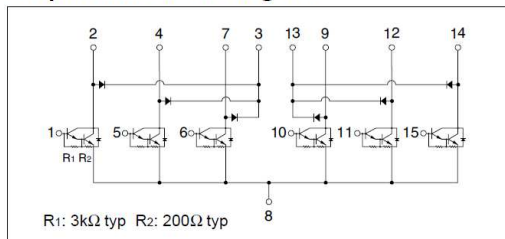

## Diode for flyback voltage absorption

(Ta=25°C)

Symbol	Specification			Unit	Conditions
	min	typ	max		
V <sub>R</sub>	120			V	I <sub>R</sub> =10μA
V <sub>F</sub>			1.8	V	I <sub>F</sub> =1A
I <sub>R</sub>			10	μA	V <sub>R</sub> =120V
t <sub>rr</sub>		100		ns	I <sub>F</sub> =±100mA

## Characteristic curves

I<sub>C</sub>-V<sub>CE</sub> Characteristics (Typical)

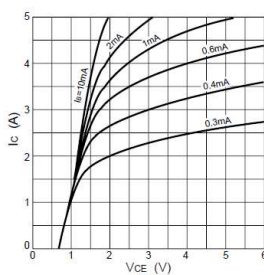

h<sub>FE</sub>-I<sub>C</sub> Characteristics (Typical)

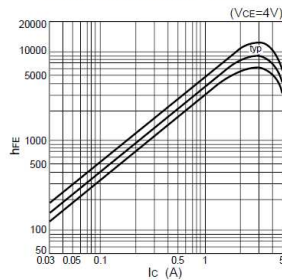

h<sub>FE</sub>-I<sub>C</sub> Temperature Characteristics (Typical)

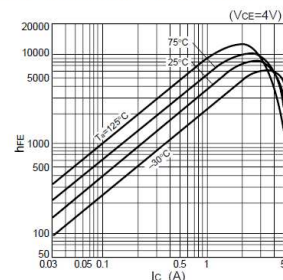

V<sub>CE(sat)</sub>-I<sub>C</sub> Temperature Characteristics (Typical)

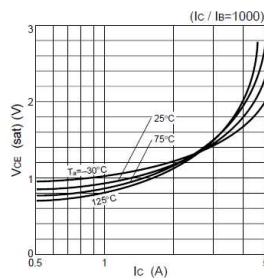

V<sub>CE(sat)</sub>-I<sub>B</sub> Characteristics (Typical)

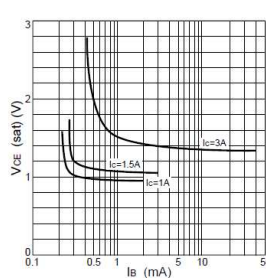

I<sub>C</sub>-V<sub>BE</sub> Temperature Characteristics (Typical)

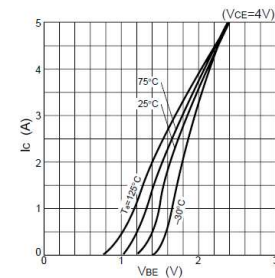

θ<sub>J-a</sub>-PW Characteristics

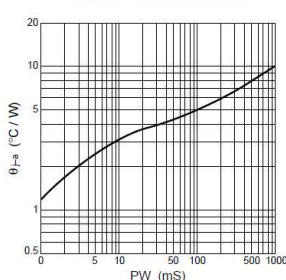

P<sub>T</sub>-T<sub>a</sub> Characteristics

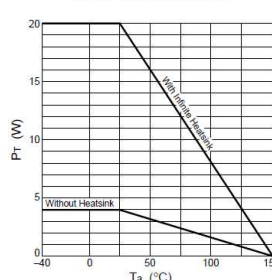

Safe Operating Area (SOA)

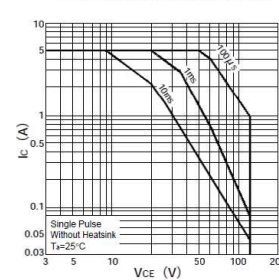

• SIP 8 (STA8Pin)

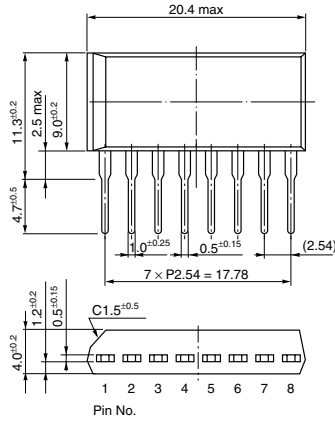

• SIP 10 (STA10Pin)

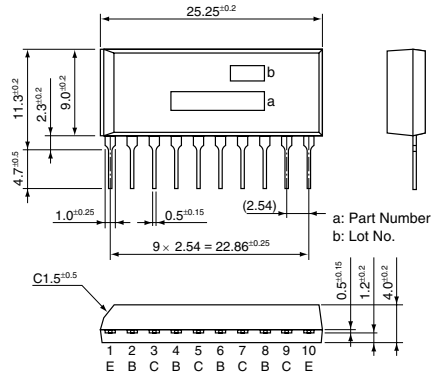

• PS 16 (Surface-Mount)

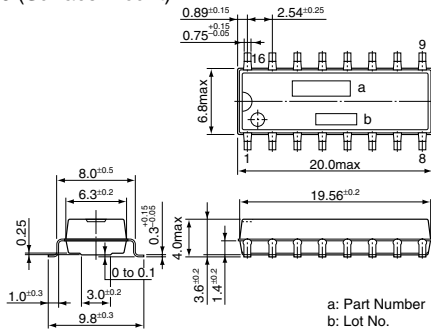

• SIP 12 (SMA12Pin)

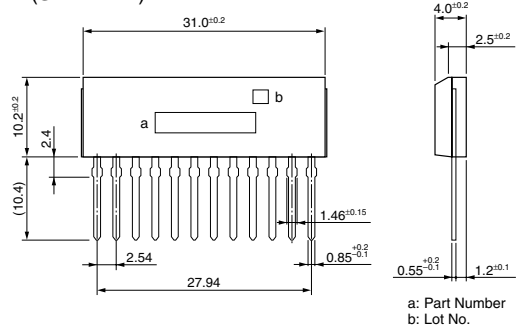

• SIP 15 (SMA15Pin)

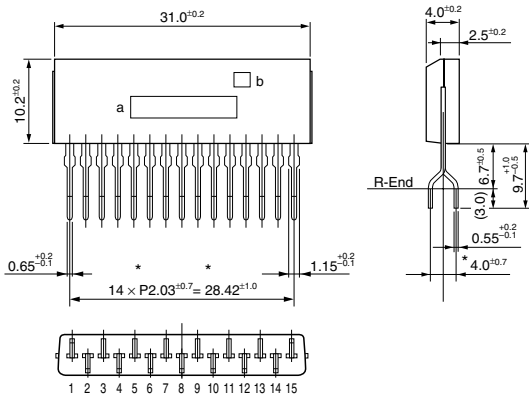

• SIP 12 with Fin (SLA12Pin)

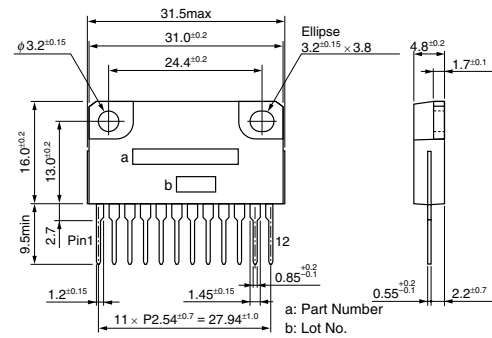

• SIP 15 with Fin (SLA15Pin)

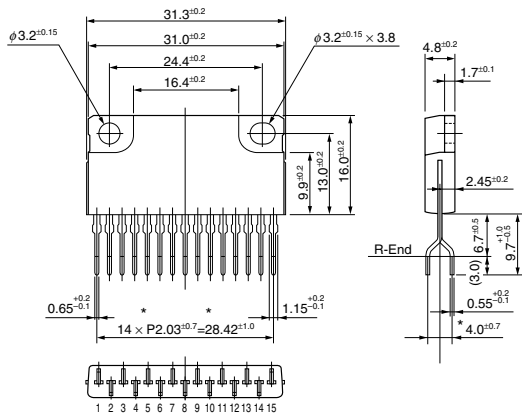

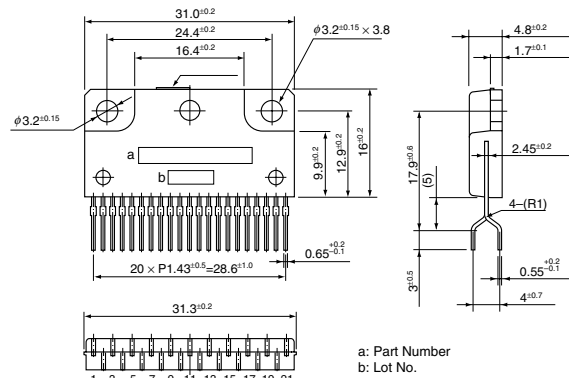

• SIP 21 with Fin (SLA21Pin)



(Unit:mm)

## Looking for pricing, stock, or lifecycle information?

Click below to explore more details on WIN SOURCE:

-  [View SMA4038 on WIN SOURCE](#)
-  [Sanken Information](#)

## Optimize Your Supply Chain with WIN SOURCE Solutions

-  Global Sourcing Solution
-  Obsolete Management
-  Cost Control Management
-  Shortage Management
-  Alternative Solution
-  Excess Inventory Management