



**THE DATASHEET OF
STP26N65DM2**



TPS7B63xx-Q1

300-mA, 40-V High-Voltage, Ultra-Low-Quiescent-Current Watchdog LDO

1 Features

- AEC-Q100 qualified for automotive applications:
 - Temperature grade 1: -40°C to 125°C , T_A
- Maximum output current: 300 mA
- 4-V to 40-V wide V_{IN} input-voltage range with up to 45-V transients
- Fixed 3.3-V and 5-V outputs
- Maximum dropout voltage: 400 mV at 300 mA
- Stable with output capacitor in wide range of capacitance (4.7 μF to 500 μF) and ESR (0.001 Ω to 20 Ω)
- Low quiescent current ($I_{(Q)}$):
 - $< 4 \mu\text{A}$ when EN is low (shutdown mode)
 - 19 μA typical at light loads with $\overline{\text{WD_EN}}$ high (watchdog disabled)
- Configurable for window watchdog or standard watchdog
- Open-to-closed window ratio configurable as 1:1 or 8:1
- Fully adjustable watchdog period (from 10 ms to 500 ms)
- 10% accurate watchdog period
- Dedicated $\overline{\text{WD_EN}}$ pin to control watchdog ON-OFF
- Fully adjustable power-good threshold and power-good delay period
- Low input-voltage tracking to UVLO
- Integrated fault protection
 - Overload current-limit protection
 - Thermal shutdown
- [Functional Safety-Capable](#)
 - Documentation available to aid functional safety system design
- 16-pin HTSSOP package

2 Applications

- Automotive MCU power supplies
- [Body control modules \(BCM\)](#)
- [Seat comfort modules](#)
- [EV and HEV battery management systems \(BMS\)](#)
- [Electronic gear shifters](#)
- [Transmissions](#)
- [Electrical power steering \(EPS\)](#)

3 Description

In automotive microcontroller or microprocessor power-supply applications, the watchdog is used to monitor the microcontroller working status to prevent software runaway. The watchdog must be independent of the microcontroller in a reliable system.

The TPS7B63xx-Q1 is a family of 300-mA watchdog low-dropout regulators (LDOs) designed for an operating voltage up to 40 V, with typical quiescent current of only 19 μA at light load. The devices integrate a programmable function for selecting a window watchdog or standard watchdog, with an external resistor to set the watchdog time within 10% accuracy.

The PG pin on the TPS7B63xx-Q1 devices indicate when the output voltage is stable and in regulation. The power-good delay period and power-good threshold can be adjusted by selecting external components. The devices also feature integrated short-circuit and overcurrent protection. The combination of such features makes these devices particularly flexible and suitable to supply microcontroller in automotive applications.

Device Information

PART NUMBER (1)	OUTPUT VOLTAGE	PACKAGE
TPS7B6333-Q1	Fixed 3.3 V	HTSSOP (16)
TPS7B6350-Q1	Fixed 5 V	

- (1) For all available packages, see the orderable addendum at the end of the data sheet.

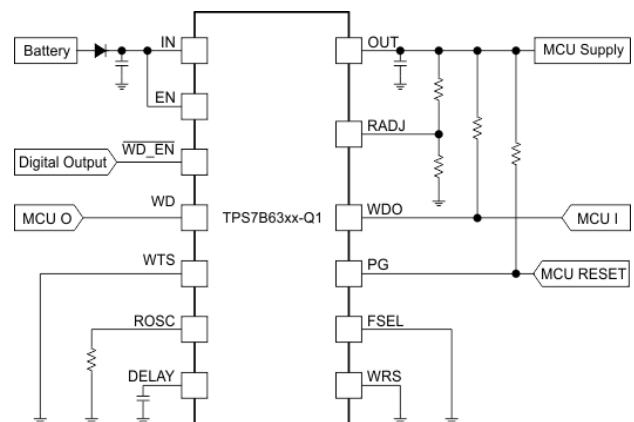

Typical Application Schematic



Table of Contents

1 Features	1	7.3 Feature Description.....	12
2 Applications	1	7.4 Device Functional Modes.....	19
3 Description	1	8 Application and Implementation	20
4 Revision History	2	8.1 Application Information.....	20
5 Pin Configuration and Functions	3	8.2 Typical Application.....	20
6 Specifications	4	8.3 Power Supply Recommendations.....	22
6.1 Absolute Maximum Ratings.....	4	8.4 Layout.....	23
6.2 ESD Ratings.....	4	9 Device and Documentation Support	24
6.3 Recommended Operating Conditions.....	4	9.1 Documentation Support.....	24
6.4 Thermal Information.....	5	9.2 Receiving Notification of Documentation Updates.....	24
6.5 Electrical Characteristics.....	5	9.3 Support Resources.....	24
6.6 Switching Characteristics.....	7	9.4 Trademarks.....	24
6.7 Typical Characteristics.....	8	9.5 Electrostatic Discharge Caution.....	24
7 Detailed Description	12	9.6 Glossary.....	24
7.1 Overview.....	12	10 Mechanical, Packaging, and Orderable Information	24
7.2 Functional Block Diagram.....	12		

4 Revision History

NOTE: Page numbers for previous revisions may differ from page numbers in the current version.

Changes from Revision B (September 2020) to Revision C (December 2022)	Page
• Changed PADJ and WTS pins to inputs instead of outputs.....	3
• Changed <i>Load Regulation</i> graph and changed VIN condition for I _{OUT} = 200 mA <i>Line Transient</i> graphs.....	8
• Changed resistor values in <i>TPS7B63xx-Q1 Typical Application Schematic</i> figure.....	20

Changes from Revision A (March 2017) to Revision B (September 2020)	Page
• Updated the numbering format for tables, figures, and cross-references throughout the document.....	1
• Changed automotive-specific applications bullets in <i>Features</i> section.....	1
• Changed accurate watchdog period from 9% to 10% in <i>Features</i> section.....	1
• Added Functional Safety-Capable bullets to <i>Features</i> section.....	1
• Changed accuracy from 9% to 10% in <i>Description</i> section.....	1
• Added ESD classification levels to <i>ESD Ratings</i> table.....	4
• Changed V _{OUT} parameter: added temperature range to test conditions of first parameter row and added second row to parameter.....	5
• Changed V _(dropout) maximum specification in second row of parameter from 260 mV to 325 mV.....	5
• Changed t _(DEGLITCH) minimum specification from 100 μs to 50 μs, changed t _(DLY_FIX) maximum specification from 550 μs to 900 μs, and deleted t _(DLY_FIX) minimum specification.....	7
• Changed fault 1 maximum open-window duration from t _(WD) / 2 to t _(WD)	18

5 Pin Configuration and Functions

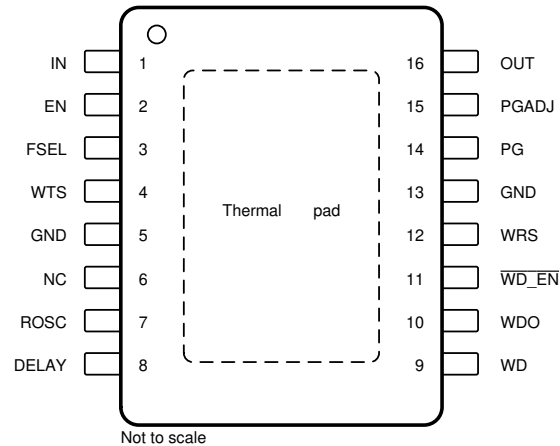

NC - No internal connection

Figure 5-1. PWP PowerPAD™ Package, 16-Pin HTSSOP With Exposed Thermal Pad (Top View)

Table 5-1. Pin Functions

PIN		TYPE	DESCRIPTION
NAME	NO.		
DELAY	8	O	Power-good delay period adjustment pin. Connect this pin with a capacitor to ground to adjust the power-good delay time.
EN	2	I	Device enable pin. Pull this pin down to low-level voltage to disable the device. Pull this pin up to high-level voltage to enable the device.
FSEL	3	I	Internal oscillator frequency selection pin. Pull this pin down to low-level voltage to select the high-frequency oscillator. Pull this pin up to high-level voltage to select the low-frequency oscillator.
GND	5, 13	—	Ground reference
IN	1	I	Device input power-supply pin
NC	6	—	Not connected
OUT	16	O	Device 3.3-V or 5-V regulated output voltage pin
PG	14	O	Power-good pin. Open-drain output pin. Pull this pin up to V_{OUT} or to a reference through a resistor. When the output voltage is not ready, this pin is pulled down to ground.
PGADJ	15	I	Power-good threshold adjustment pin. Connect a resistor divider between the PGADJ and OUT pins to set the power-good threshold. Connect this pin to ground to set the threshold to 91.6% of output voltage V_{OUT} .
ROSC	7	O	Watchdog timer adjustment pin. Connect a resistor between the ROSC pin and the GND pin to set the duration of the watchdog monitor. Leaving this pin open or connecting this pin to ground results in the watchdog reporting a fault at the watchdog output (WDO).
WD	9	I	Watchdog service-signal input pin.
WDO	10	O	Watchdog status pin. Open-drain output pin. Pull this pin up to OUT or a reference voltage through a resistor. When watchdog fault occurs, this pin is pulled down to a low-level voltage.
WD_EN	11	I	Watchdog enable pin. Pull this pin down to a low level to enable the watchdog. Pull this pin up to a high level to disable the watchdog.
WRS	12	I	Window ratio selection pin (only applicable for the window watchdog). Pull this pin down to a low level to set the open:closed window ratio to 1:1. Pull this pin up to high level to set the open:closed window ratio to 8:1.
WTS	4	I	Watchdog type-selection pin. To set the window watchdog, connect this pin to the GND pin. To set the standard watchdog, pull this pin high.
Thermal pad	—	—	Solder to board to improve the thermal performance.

6 Specifications

6.1 Absolute Maximum Ratings

over operating ambient temperature range (unless otherwise noted)^{(1) (2)}

		MIN	MAX	UNIT
Unregulated input	IN, EN	-0.3	45	V
Internal oscillator reference voltage	ROSC	-0.3	7	V
Power-good delay-timer output	DELAY	-0.3	7	V
Regulated output	OUT	-0.3	7	V
Power-good output voltage	PG	-0.3	7	V
Watchdog status output voltage	WDO	-0.3	7	V
Watchdog frequency selection, watchdog-type selection	FSEL, WTS	-0.3	45	V
Watchdog enable	WD_EN	-0.3	7	V
Watchdog service signal voltage	WD	-0.3	7	V
Window ratio selection	WRS	-0.3	7	V
Power-good threshold-adjustment voltage	PGADJ	-0.3	7	V
Operating junction temperature, T _J		-40	150	°C
Storage temperature, T _{stg}		-65	150	°C

- (1) Stresses beyond those listed under *Absolute Maximum Ratings* may cause permanent damage to the device. These are stress ratings only, which do not imply functional operation of the device at these or any other conditions beyond those indicated under *Recommended Operating Conditions*. Exposure to absolute-maximum-rated conditions for extended periods may affect device reliability.
- (2) All voltage values are with respect to ground.

6.2 ESD Ratings

			VALUE	UNIT	
V _(ESD)	Electrostatic discharge	Human-body model (HBM), per AEC Q100-002 ⁽¹⁾ , device HBM ESD classification level 2	±2000	V	
		Charged-device model (CDM), per AEC Q100-011, device CDM ESD classification level C4B	All pins		±500
			Corner pins (1, 14, 15, and 28)		±750

- (1) AEC Q100-002 indicates that HBM stressing shall be in accordance with the ANSI/ESDA/JEDEC JS-001 specification.

6.3 Recommended Operating Conditions

Over operating ambient temperature range (unless otherwise noted)

		MIN	MAX	UNIT
Unregulated input	IN	4	40	V
40-V pins	EN, FSEL, WTS	0	V _{IN}	V
Regulated output	OUT	0	5.5	V
Power good, watchdog status, reference oscillator	PG, WDO, ROSC	0	5.5	V
Low voltage pins	WD, WD_EN, PGADJ, DELAY, WRS	0	5.5	V
Output current		0	300	mA
Ambient temperature, T _A		-40	125	°C

6.4 Thermal Information

THERMAL METRIC ⁽¹⁾		TPS7B63xx-Q1	UNIT
		PWP (HTSSOP)	
		16 PINS	
R _{θJA}	Junction-to-ambient thermal resistance	39.7	°C/W
R _{θJC(top)}	Junction-to-case (top) thermal resistance	28.9	°C/W
R _{θJB}	Junction-to-board thermal resistance	23.8	°C/W
ψ _{JT}	Junction-to-top characterization parameter	1.3	°C/W
ψ _{JB}	Junction-to-board characterization parameter	23.7	°C/W
R _{θJC(bot)}	Junction-to-case (bottom) thermal resistance	3.1	°C/W

(1) For more information about traditional and new thermal metrics, see the [Semiconductor and IC Package Thermal Metrics application report](#).

6.5 Electrical Characteristics

V_{IN} = 14 V, C_{OUT} ≥ 4.7 μF, 1 mΩ < ESR < 20 Ω, and T_J = –40°C to 150°C (unless otherwise noted)

PARAMETER		TEST CONDITIONS	MIN	TYP	MAX	UNIT
SUPPLY VOLTAGE AND CURRENT (IN)						
V _{IN}	Input voltage		4		40	V
I _(SLEEP)	Input sleep current	EN = OFF			4	μA
I _(Q)	Input quiescent current	V _{IN} = 5.6 V to 40 V for fixed 5-V V _{OUT} ; V _{IN} = 4 V to 40 V for fixed 3.3-V V _{OUT} ; EN = ON; watchdog disabled; I _{OUT} < 1 mA; T _J < 80°C		19	29.6	μA
		V _{IN} = 5.6 V to 40 V for fixed 5-V V _{OUT} ; V _{IN} = 4 V to 40 V for fixed 3.3-V V _{OUT} ; EN = ON; watchdog enabled; I _{OUT} < 1 mA		28	42	
		V _{IN} = 5.6 V to 40 V for fixed 5-V V _{OUT} ; V _{IN} = 4 V to 40 V for fixed 3.3-V V _{OUT} ; EN = ON; watchdog enabled; I _{OUT} < 100 mA		78	98	
V _(UVLO)	Undervoltage lockout, falling	Ramp V _{IN} down until output is turned off			2.6	V
V _(UVLO_HYST)	UVLO hysteresis			0.5		V
ENABLE INPUT, WATCHDOG TYPE SELECTION AND FSEL (EN, WTS, AND FSEL)						
V _{IL}	Low-level input voltage				0.7	V
V _{IH}	High-level input voltage		2			V
V _{hys}	Hysteresis			150		mV
WATCHDOG ENABLE (WD_EN PIN)						
V _{IL}	Low-level input threshold voltage for watchdog enable pin	Watchdog enabled			0.7	V
V _{IH}	High-level input threshold voltage for watchdog enable pin	Watchdog disabled	2			V
I _{WD_EN}	Pulldown current for watchdog enable pin	V _{WD_EN} = 5 V			3	μA
REGULATED OUTPUT (OUT)						
V _{OUT}	Regulated output	V _{IN} = 5.6 V to 40 V for fixed 5-V V _{OUT} ; V _{IN} = 4 V to 40 V for fixed 3.3-V V _{OUT} ; I _{OUT} = 0 to 300 mA, –40°C ≤ T _J ≤ 125°C	–2%		2%	
		V _{IN} = 5.6 V to 40 V for fixed 5-V V _{OUT} ; V _{IN} = 4 V to 40 V for fixed 3.3-V V _{OUT} ; I _{OUT} = 0 to 300 mA	–2.5%		2.5%	
ΔV _{OUT(ΔVIN)}	Line regulation	V _{IN} = 5.6 V to 40 V			10	mV

6.5 Electrical Characteristics (continued)

 $V_{IN} = 14\text{ V}$, $C_{OUT} \geq 4.7\ \mu\text{F}$, $1\ \text{m}\Omega < \text{ESR} < 20\ \Omega$, and $T_J = -40^\circ\text{C}$ to 150°C (unless otherwise noted)

PARAMETER		TEST CONDITIONS	MIN	TYP	MAX	UNIT
$\Delta V_{OUT(\Delta I_{OUT})}$	Load regulation	$I_{OUT} = 1\ \text{mA}$ to $300\ \text{mA}$			20	mV
$V_{(\text{dropout})}$	Dropout voltage ($V_{IN} - V_{OUT}$)	$I_{OUT} = 300\ \text{mA}^{(2)}$		300	400	mV
		$I_{OUT} = 200\ \text{mA}^{(2)}$		170	325	
I_{OUT}	Output current	V_{OUT} in regulation	0		300	mA
$I_{(\text{LIM})}$	Output current limit	V_{OUT} shorted to ground, $V_{IN} = 5.6\ \text{V}$ to $40\ \text{V}$	301	680	1000	mA
PSRR	Power-supply ripple rejection ⁽¹⁾	$I_{OUT} = 100\ \text{mA}$; $C_{OUT} = 10\ \mu\text{F}$; frequency (f) = 100 Hz		60		dB
		$I_{OUT} = 100\ \text{mA}$; $C_{OUT} = 10\ \mu\text{F}$; frequency (f) = 100 kHz		40		
POWER-GOOD (PG, PGADJ)						
$V_{OL(\text{PG})}$	PG output, low voltage	$I_{OL} = 5\ \text{mA}$, PG pulled low			0.4	V
$I_{\text{kg}(\text{PG})}$	PG pin leakage current	PG pulled to V_{OUT} through a 10-k Ω resistor			1	μA
$V_{(\text{PG_TH})}$	Default power-good threshold	V_{OUT} powered above the internally set tolerance, PGADJ pin shorted to ground	89.6	91.6	93.6	% of V_{OUT}
$V_{(\text{PG_HYST})}$	Power-good hysteresis	V_{OUT} falling below the internally set tolerance hysteresis		2		% of V_{OUT}
PGADJ						
$V_{(\text{PGADJ_TH})}$	Switching voltage for the power-good adjust pin	V_{OUT} is falling	1.067	1.1	1.133	V
POWER-GOOD DELAY						
$I_{(\text{DLY_CHG})}$	DELAY capacitor charging current		3	5	10	μA
$V_{(\text{DLY_TH})}$	DELAY pin threshold to release PG high	Voltage at DELAY pin is ramped up	0.95	1	1.05	V
$I_{(\text{DLY_DIS})}$	DELAY capacitor discharging current	$V_{\text{DELAY}} = 1\ \text{V}$	0.5			mA
CURRENT VOLTAGE REFERENCE (ROSC)						
V_{ROSC}	Voltage reference		0.95	1	1.05	V
WATCHDOG (WD, WDO, WRS)						
V_{IL}	Low-level threshold voltage for the watchdog input and window-ratio select	For WD and WRS pins			30	% of V_{OUT}
V_{IH}	High-level threshold voltage for the watchdog input and window-ratio select	For WD and WRS pins	70			% of V_{OUT}
$V_{(\text{HYST})}$	Hysteresis			10		% of V_{OUT}
I_{WD}	Pulldown current for the WD pin	$V_{\text{WDO}} = 5\ \text{V}$		2	4	μA
V_{OL}	Low-level watchdog output	$I_{\text{WDO}} = 5\ \text{mA}$			0.4	V
I_{kg}	WDO pin leakage current	WDO pin pulled to V_{OUT} through 10-k Ω resistor			1	μA
OPERATING TEMPERATURE RANGE						
T_J	Junction temperature		-40		150	$^\circ\text{C}$
$T_{(\text{SD})}$	Junction shutdown temperature			175		$^\circ\text{C}$
$T_{(\text{HYST})}$	Hysteresis of thermal shutdown			25		$^\circ\text{C}$

(1) Design information – not tested, determined by characterization.

(2) This test is done with V_{OUT} in regulation, measuring the $V_{IN} - V_{OUT}$ when V_{OUT} drops by 100 mV from the rated output voltage at the specified load.

6.6 Switching Characteristics

$V_I = 14\text{ V}$, $C_O \geq 4.7\text{ }\mu\text{F}$, $1\text{ m}\Omega < \text{ESR} < 20\text{ }\Omega$, and $T_J = -40^\circ\text{C}$ to 150°C (unless otherwise noted)

PARAMETER		TEST CONDITIONS	MIN	TYP	MAX	UNIT
POWER-GOOD DELAY (DELAY)						
$t_{(\text{DEGLITCH})}$	Power-good deglitch time		50	180	250	μs
$t_{(\text{DLY_FIX})}$	Fixed power-good delay	No capacitor connect at DELAY pin		248	900	μs
$t_{(\text{DLY})}$	Power-on-reset delay	Delay capacitor value: $C_{(\text{DELAY})} = 100\text{ nF}$		20		ms
WATCHDOG (WD, WDO, WRS)						
$t_{(\text{WD})}$	Watchdog window duration	$R_{(\text{ROSC})} = 20\text{ k}\Omega \pm 1\%$, FSEL = LOW	9	10	11	ms
		$R_{(\text{ROSC})} = 20\text{ k}\Omega \pm 1\%$, FSEL = HIGH	45	50	55	
$t_{(\text{WD_TOL})}$	Tolerance of watchdog window duration using external resistor	Excludes tolerance of $R_{(\text{ROSC})} = 20\text{ k}\Omega$ to $100\text{ k}\Omega$	-10%		10%	
$t_{p(\text{WD})}$	Watchdog service-signal duration		100			μs
$t_{(\text{WD_HOLD})}$	Watchdog output resetting time (percentage of settled watchdog window duration)			20		% of $t_{(\text{WD})}$
$t_{(\text{WD_RESET})}$	Watchdog output resetting time	$R_{(\text{ROSC})} = 20\text{ k}\Omega \pm 1\%$, FSEL = LOW	1.8	2	2.2	ms
		$R_{(\text{ROSC})} = 20\text{ k}\Omega \pm 1\%$, FSEL = HIGH	9	10	11	

6.7 Typical Characteristics

at $V_{IN} = 14\text{ V}$, $V_{EN} \geq 2\text{ V}$, and $T_J = -40^\circ\text{C}$ to $+150^\circ\text{C}$ (unless otherwise noted)

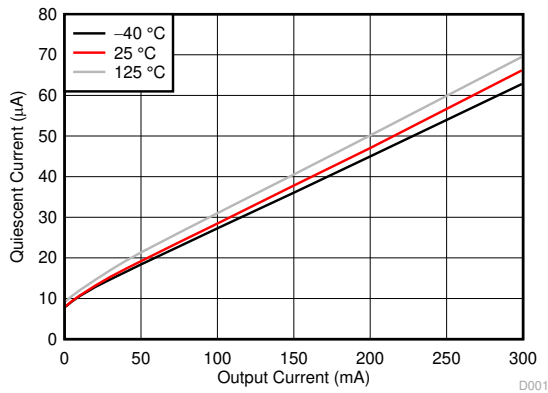

Figure 6-1. Quiescent Current vs Output Current

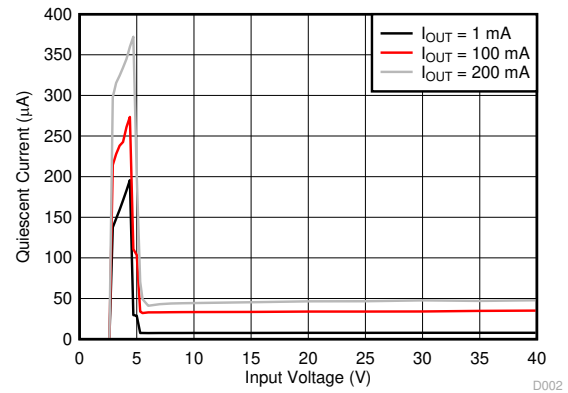

Figure 6-2. Quiescent Current vs Input Voltage

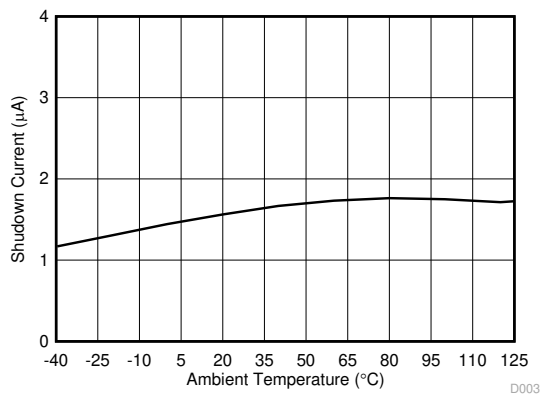

Figure 6-3. Shutdown Current vs Ambient Temperature

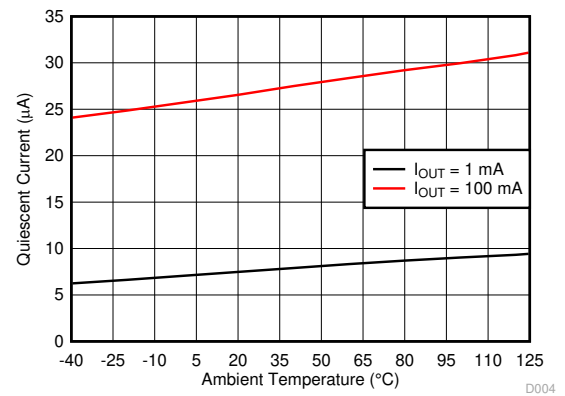

Figure 6-4. Quiescent Current vs Ambient Temperature

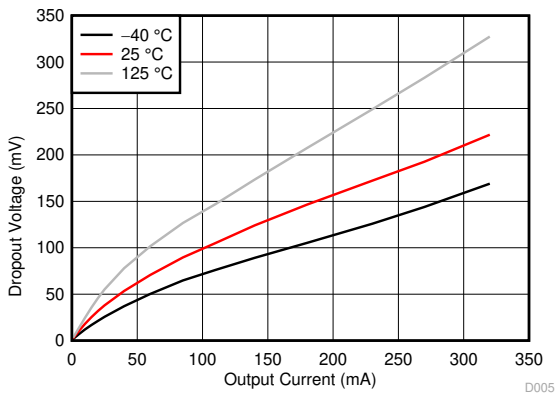

Figure 6-5. Dropout Voltage vs Output Current

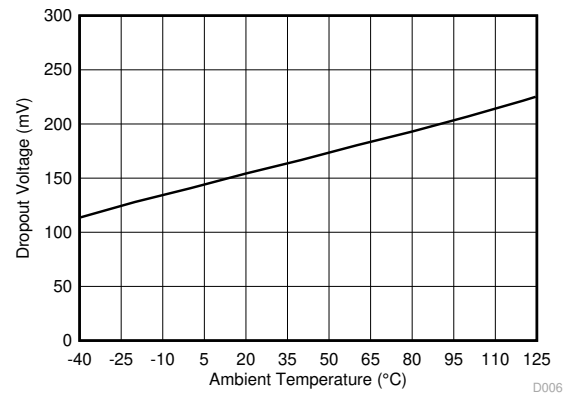

Figure 6-6. Dropout Voltage vs Ambient Temperature

6.7 Typical Characteristics (continued)

at $V_{IN} = 14\text{ V}$, $V_{EN} \geq 2\text{ V}$, and $T_J = -40^\circ\text{C}$ to $+150^\circ\text{C}$ (unless otherwise noted)

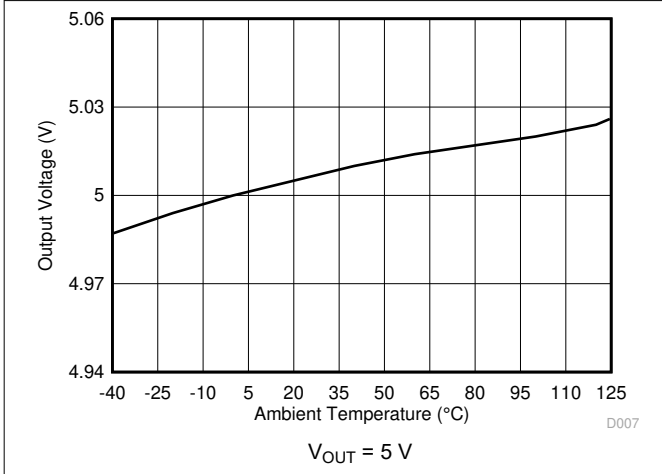

Figure 6-7. Output Voltage vs Ambient Temperature

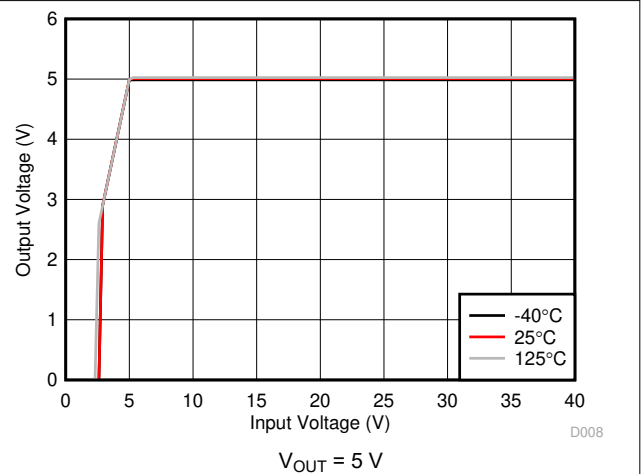

Figure 6-8. Output Voltage vs Input Voltage

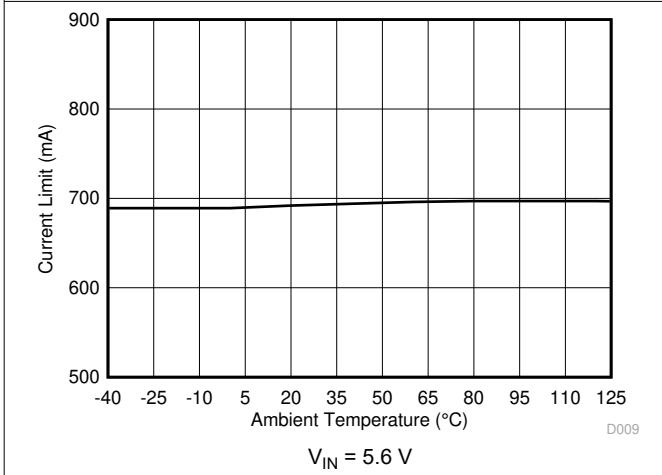

Figure 6-9. Output Current Limit (I_{LIM}) vs Ambient Temperature

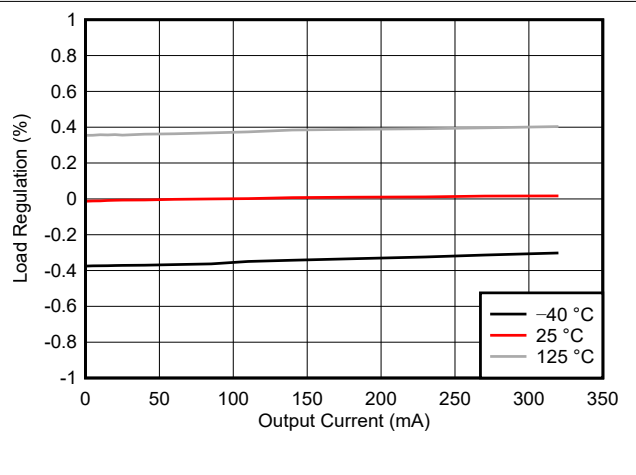

Figure 6-10. Load Regulation

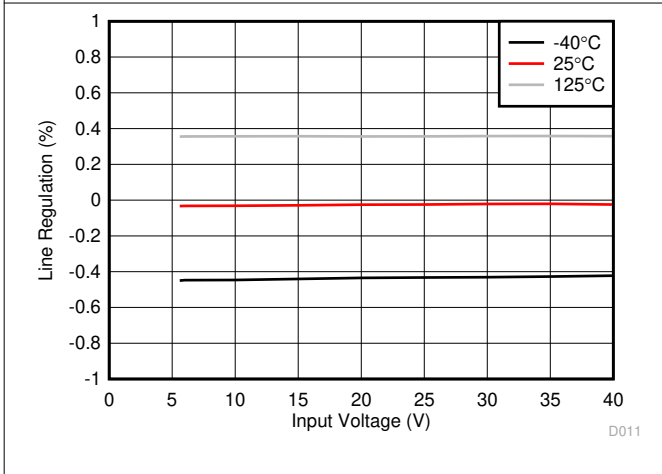

Figure 6-11. Line Regulation

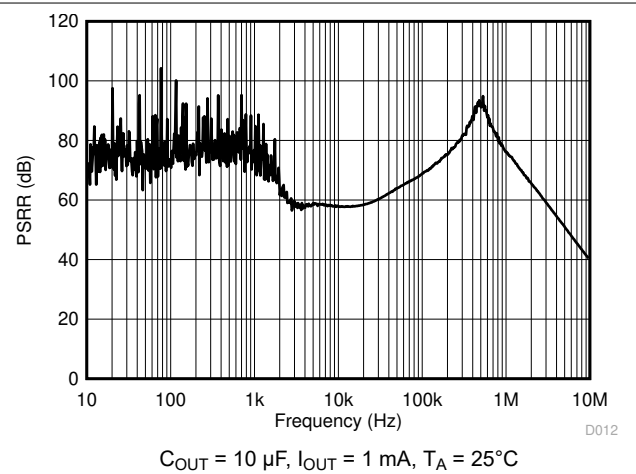
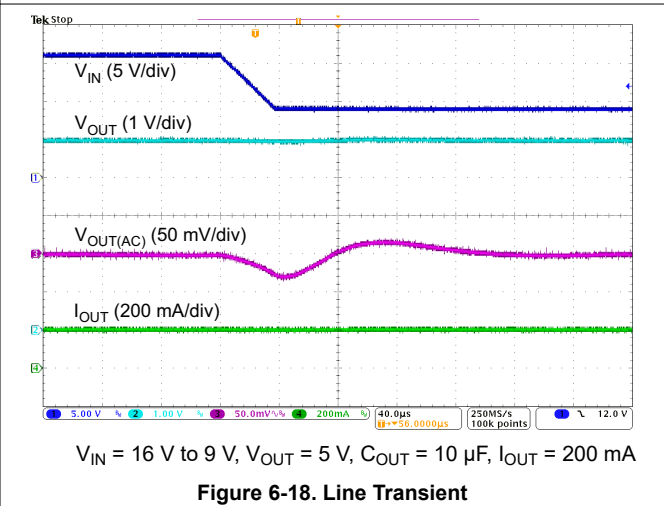
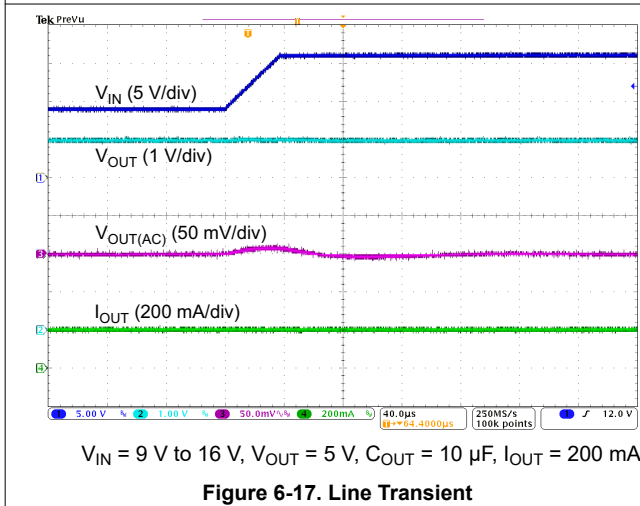
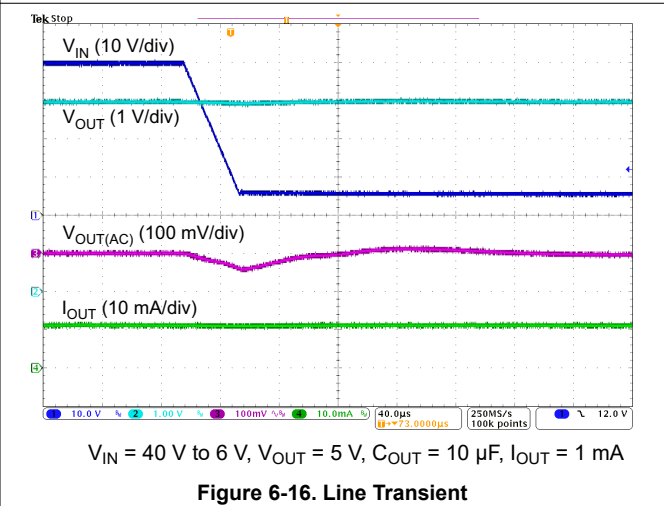
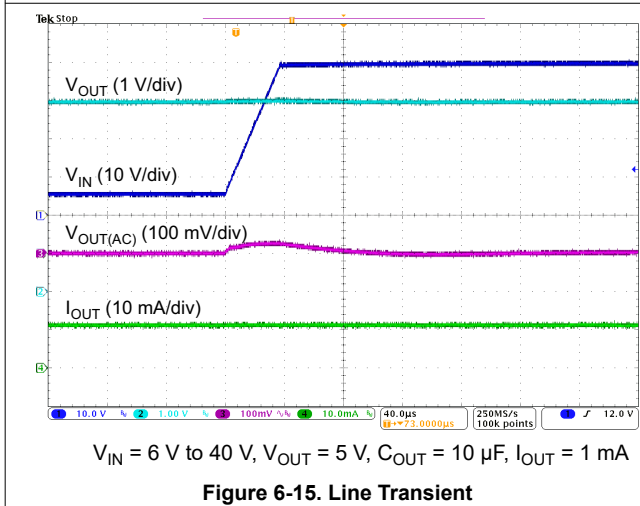
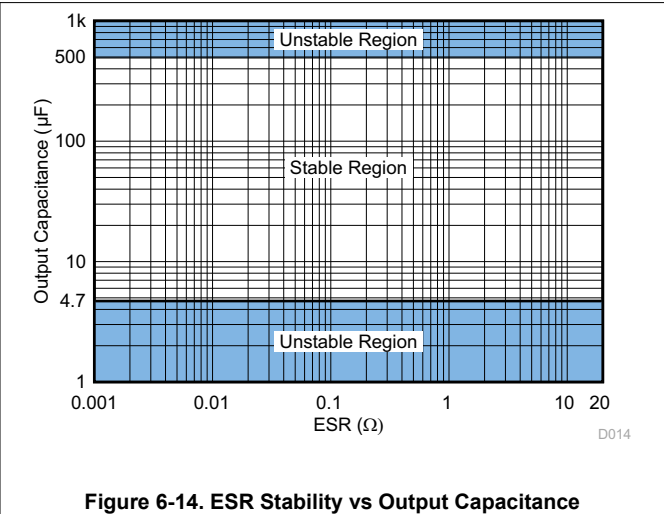
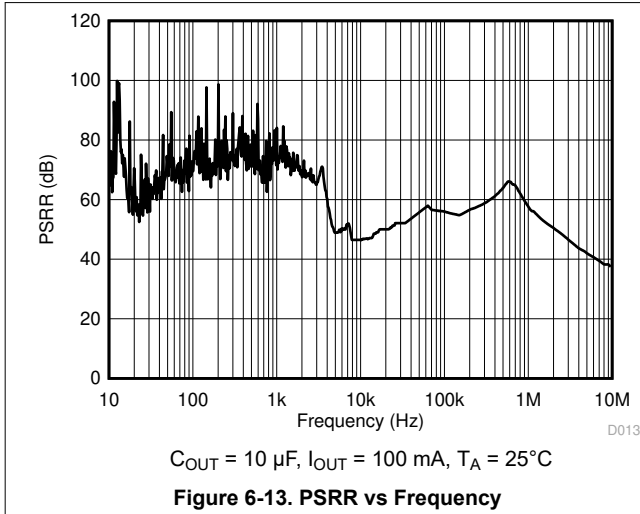

Figure 6-12. PSRR vs Frequency

6.7 Typical Characteristics (continued)

at $V_{IN} = 14\text{ V}$, $V_{EN} \geq 2\text{ V}$, and $T_J = -40^\circ\text{C}$ to $+150^\circ\text{C}$ (unless otherwise noted)



6.7 Typical Characteristics (continued)

at $V_{IN} = 14\text{ V}$, $V_{EN} \geq 2\text{ V}$, and $T_J = -40^\circ\text{C}$ to $+150^\circ\text{C}$ (unless otherwise noted)

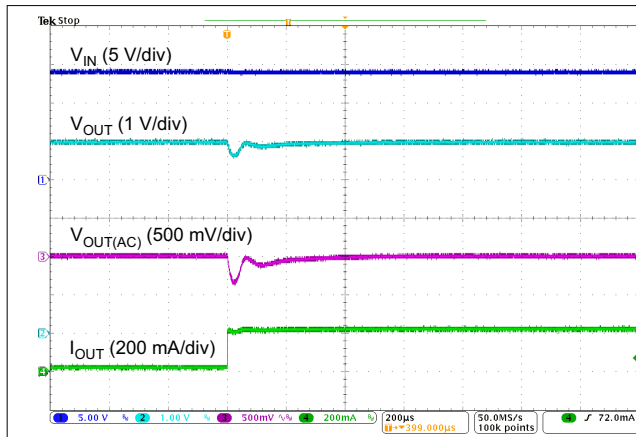

$V_{OUT} = 5\text{ V}$, $C_{OUT} = 10\text{ }\mu\text{F}$, $I_{OUT} = 1\text{ mA}$ to 200 mA

Figure 6-19. Load Transient

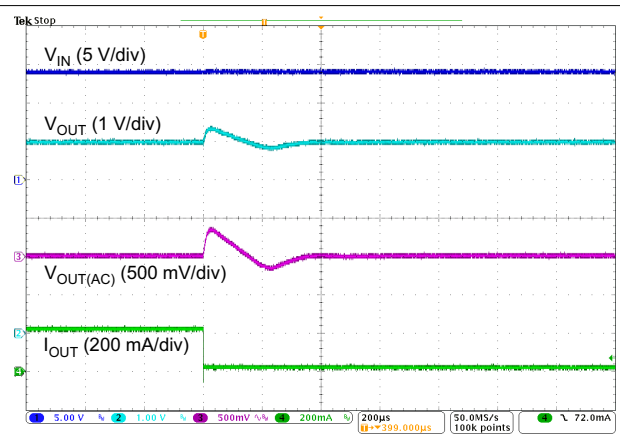

$V_{OUT} = 5\text{ V}$, $C_{OUT} = 10\text{ }\mu\text{F}$, $I_{OUT} = 200\text{ mA}$ to 1 mA

Figure 6-20. Load Transient

7 Detailed Description

7.1 Overview

The TPS7B63xx-Q1 device is a family of 300-mA, 40-V monolithic low-dropout linear voltage regulators with integrated watchdog and adjustable power-good threshold functionality. These voltage regulators consume only 19- μ A quiescent current in light-load applications. Because of the adjustable power-good delay (also called power-on-reset delay) and the adjustable power-good threshold, these devices are well-suited as power supplies for microprocessors and microcontrollers in automotive applications.

7.2 Functional Block Diagram

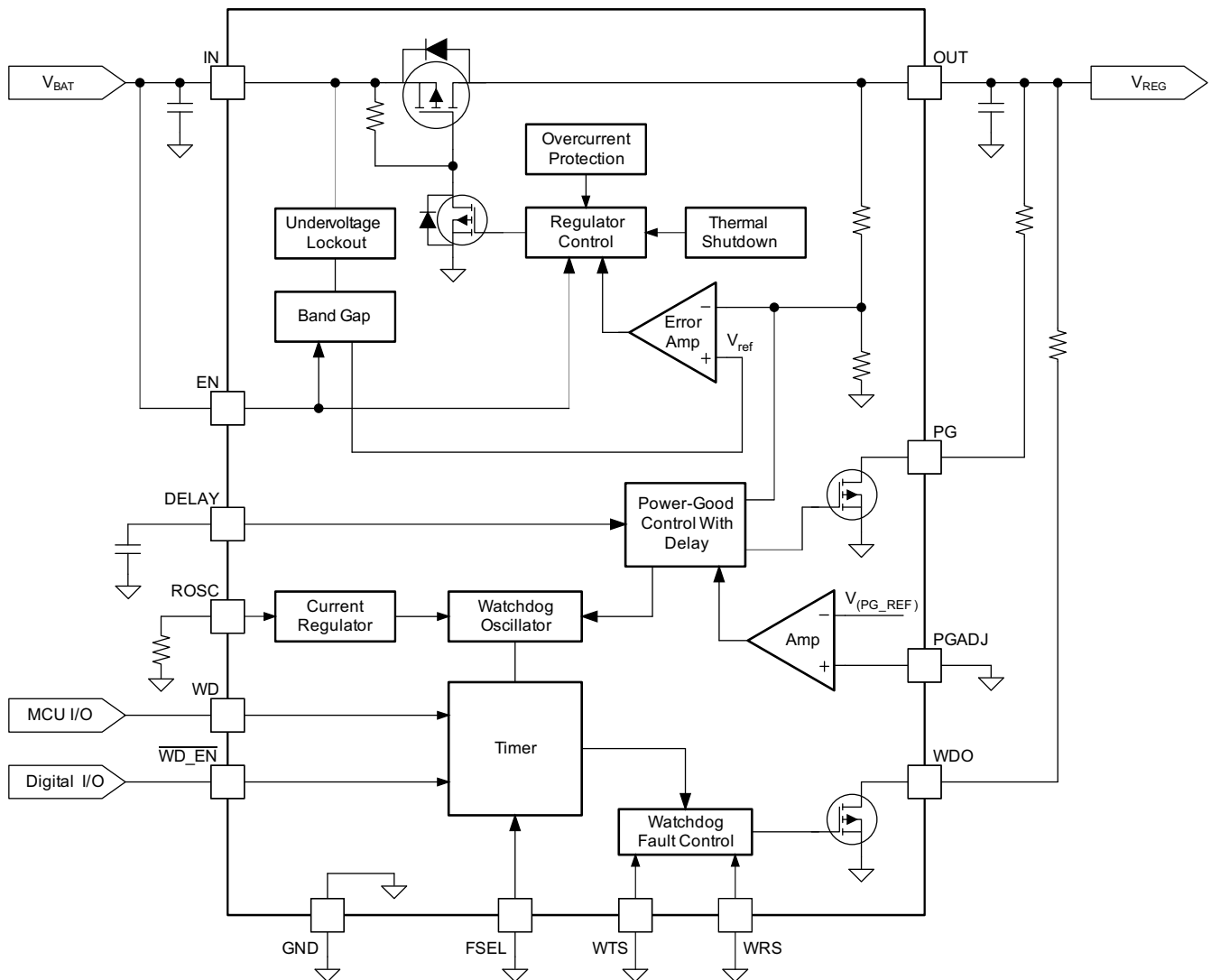

7.3 Feature Description

7.3.1 Device Enable (EN)

The EN pin is a high-voltage-tolerant pin. A high input activates the device and turns the regulator ON. Connect this input pin to an external microcontroller or a digital control circuit to enable and disable the device, or connect to the IN pin for self-bias applications.

7.3.2 Adjustable Power-Good Threshold (PG, PGADJ)

The PG pin is an open-drain output with an external pullup resistor to the regulated supply, and the PGADJ pin is a power-good threshold adjustment pin. Connecting the PGADJ pin to GND sets the power-good threshold value to the default, $V_{(PG_TH)}$. When V_{OUT} exceeds the default power-good threshold, the PG output turns high after the power-good delay period has expired. When V_{OUT} falls below $V_{(PG_TH)} - V_{(PG_HYST)}$, the PG output turns low after a short deglitch time.

The power-good threshold is also adjustable from 1.1 V to 5 V by using an external resistor divider between PGADJ and OUT. The threshold can be calculated using Equation 1:

$$V_{(PG_ADJ) \text{ falling}} = V_{(PGADJ_TH) \text{ falling}} \times \frac{R1 + R2}{R2}$$

$$V_{(PG_ADJ) \text{ rising}} = \left[V_{(PGADJ_TH) \text{ falling}} + 26 \text{ mV (typ)} \right] \times \frac{R1 + R2}{R2} \quad (1)$$

where

- $V_{(PG_ADJ)}$ is the adjustable power-good threshold
- $V_{(PG_REF)}$ is the internal comparator reference voltage of the PGADJ pin, 1.1 V typical, 2% accuracy specified under all conditions

By setting the power-good threshold $V_{(PG_ADJ)}$, when V_{OUT} exceeds this threshold, the PG output turns high after the power-good delay period has expired. When V_{OUT} falls below $V_{(PG_ADJ)} - V_{(PG_HYST)}$, the PG output turns low after a short deglitch time. Figure 7-1 shows typical hardware connections for the PGADJ pin and DELAY pin.

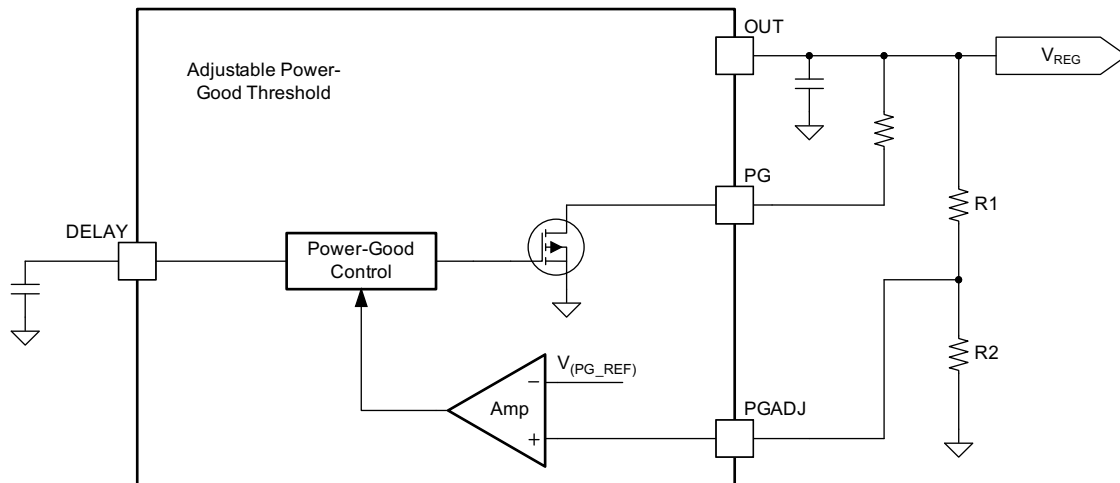

Figure 7-1. Adjustable Power-Good Threshold

7.3.3 Adjustable Power-Good Delay Timer (DELAY)

The power-good delay period is a function of the value set by an external capacitor on the DELAY pin before turning the PG pin high. Figure 7-2 illustrates typical power-good and delay behavior. Connecting an external capacitor from this pin to GND sets the power-good delay period. The constant current charges an external capacitor until the voltage exceeds a threshold to trip an internal comparator, and Equation 2 determines the power-good delay period:

$$t_{(DLY)} = t_{dly_fix} + \frac{C_{DELAY} \times 1V}{5 \mu A} \quad (2)$$

where

- $t_{(DLY)}$ is the adjustable power-good delay period
- C_{DELAY} is the value of the power-good delay capacitor

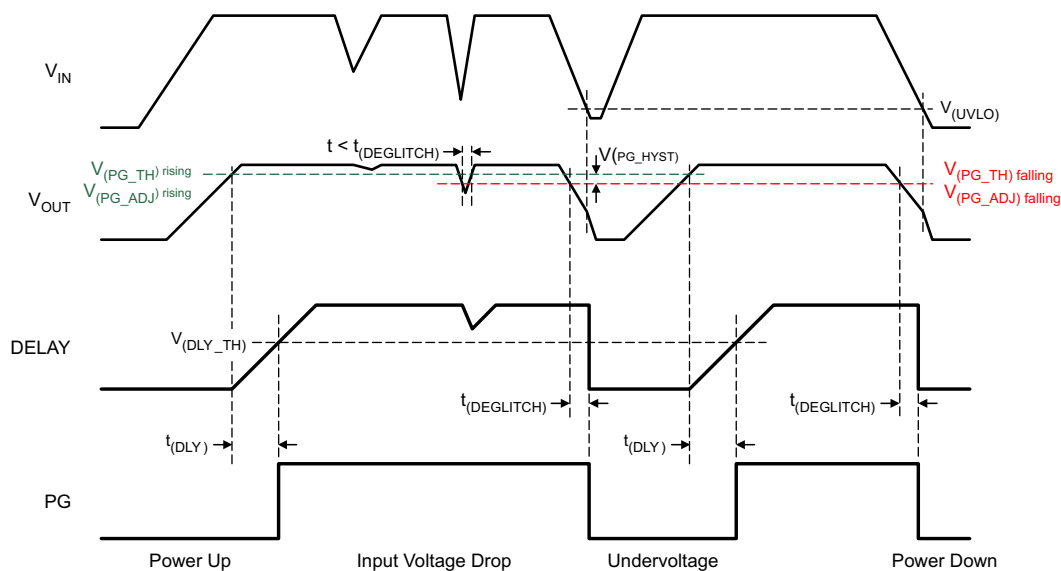

Figure 7-2. Power Up and Conditions for Activating Power-Good

If the DELAY pin is open, the default delay time is $t_{(DLY_FIX)}$.

7.3.4 Undervoltage Shutdown

These devices have an integrated undervoltage lockout (UVLO) circuit to shut down the output if the input voltage falls below an internal UVLO threshold, $V_{(UVLO)}$. This ensures that the regulator does not latch into an unknown state during low-input-voltage conditions. If the input voltage has a negative transient which drops below the UVLO threshold and recovers, the regulator shuts down and powers up with a normal power-up sequence once the input voltage is above the required level.

7.3.5 Current Limit

These devices feature current-limit protection to keep the device in a safe operating area when an overload or output short-to-ground condition occurs. This protects devices from excessive power dissipation. For example, during a short-circuit condition on the output, fault protection limits the current through the pass element to $I_{(LIM)}$ to protect the device from excessive power dissipation.

7.3.6 Thermal Shutdown

These devices incorporate a thermal shutdown (TSD) circuit as a protection from overheating. For continuous normal operation, the junction temperature should not exceed the TSD trip point. The junction temperature exceeding the TSD trip point causes the output to turn off. When the junction temperature falls below the $T_{(SD)} - T_{(HYST)}$, the output turns on again.

7.3.7 Integrated Watchdog

These devices have an integrated watchdog with fault (WDO) output option. Both window watchdog and standard watchdog are available in one device. The watchdog operation, service fault conditions, and differences between window watchdog and standard watchdog are described as follows.

7.3.7.1 Window Watchdog (WTS, ROSC, FSEL and WRS)

These devices work in the window watchdog mode when the watchdog type selection (WTS) pin is connected to a low voltage level. The user can set the duration of the watchdog window by connecting an external resistor (R_{ROSC}) to ground at the ROSC pin and setting the voltage level at the FSEL pin. The current through the R_{ROSC} resistor sets the clock frequency of the internal oscillator. The user can adjust the duration of the watchdog window (the watchdog timer period) by changing the resistor value. A high voltage level at the FSEL pin sets the watchdog window duration to 5 times as long as that of a low voltage level with same external component configuration.

The duration of the watchdog window and the duration of the fault output are multiples of the internal oscillator frequency, as shown by the following equations:

$$\text{FSEL low} \quad t_{(WD)} = R_{ROSC} \times 0.5 \times 10^{-6} \quad (3)$$

$$\text{FSEL high} \quad t_{(WD)} = R_{ROSC} \times 2.5 \times 10^{-6} \quad (4)$$

$$\text{Watchdog initialization} \quad t_{(WD_INI)} = 8 \times t_{(WD)} \quad (5)$$

$$\text{Open and closed windows} \quad t_{(WD)} = t_{(OW)} + t_{(CW)} \quad (6)$$

$$\text{WRS low} \quad t_{(OW)} = t_{(CW)} = 50\% \times t_{(WD)} \quad (7)$$

$$\text{WRS high} \quad t_{(OW)} = 8 \times t_{(CW)} = (8 / 9) \times t_{(WD)} \quad (8)$$

where:

- $t_{(WD)}$ is the duration of the watchdog window
- R_{ROSC} is the resistor connected at the ROSC pin
- $t_{(WD_INI)}$ is the duration of the watchdog initialization
- $t_{(OW)}$ is the duration of the open watchdog window
- $t_{(CW)}$ is the duration of the closed watchdog window

For all the foregoing items, the unit of resistance is Ω and the unit of time is s.

[Table 7-1](#) illustrates several periods of watchdog window with typical conditions.

Table 7-1. Several Typical Periods of Watchdog Window

FSEL	R _(ROSC) (kΩ)	I _(ROSC) (μA)	t _(WD) (ms)	WATCHDOG PERIOD TOLERANCE
High	200	5	500	15%
	100	10	250	10%
	50	20	125	
	40	25	100	
	25	40	62.5	
	20	50	50	
Low	100	10	50	10%
	50	20	25	
	40	25	20	
	25	40	12.5	
	20	50	10	

As illustrated in Figure 7-3, each watchdog window consists of an open window and a closed window. While the window ratio selection (WRS) pin is low, each open window (t_(OW)) and closed window (t_(CW)) has a width approximately 50% of the watchdog window (t_(WD)). While the WRS pin is high, the ratio between open window and closed window is about 8:1. However, there is an exception to this; the first open window after watchdog initialization (t_(WD_INI)) is eight times the duration of the watchdog window. The watchdog must receive the service signal (by software, external microcontroller, and so forth) during this initialization open window.

A watchdog fault occurs when servicing the watchdog during a closed window, or not servicing during an open window.

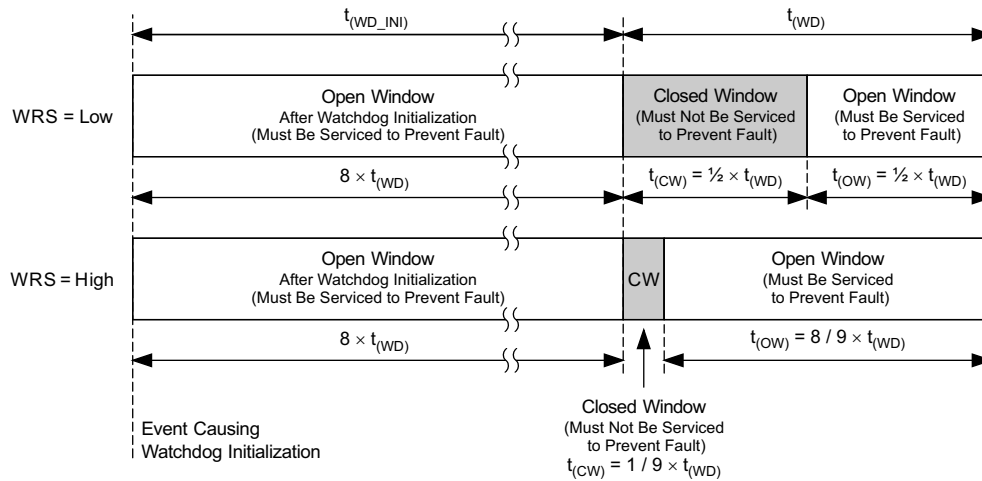

Figure 7-3. Watchdog Initialization, Open Window and Closed Window

7.3.7.2 Standard Watchdog (WTS, ROSC and FSEL)

These devices work in the standard watchdog mode when the watchdog type selection (WTS) pin is connected to a high voltage level. The same as in window watchdog mode, the user can set the duration of the watchdog window by adjusting the external resistor (R_{ROSC}) value at the ROSC pin and setting the voltage level at the FSEL pin. The current through the R_{ROSC} resistor sets the clock frequency of the internal oscillator. The user can adjust the duration of the watchdog window (the watchdog timer period) by changing the resistor value. A high voltage level at the FSEL pin sets the watchdog window duration to 5 times as long as that of a low voltage level with same external component configuration.

The duration of the watchdog window and the duration of the fault output are multiples of the internal oscillator frequency, as shown by the following equations:

$$\text{FSEL low} \quad t_{(WD)} = R_{ROSC} \times 0.5 \times 10^{-6} \quad (9)$$

$$\text{FSEL high} \quad t_{(WD)} = R_{ROSC} \times 2.5 \times 10^{-6} \quad (10)$$

$$\text{Watchdog initialization} \quad t_{(WD_INI)} = 8 \times t_{(WD)} \quad (11)$$

where:

- $t_{(WD)}$ is the duration of the watchdog window
- R_{ROSC} is the resistor connected at the RO SC pin
- $t_{(WD_INI)}$ is the duration of the watchdog initialization

For all the foregoing items, the unit of resistance is Ω and the unit of time is s

Compared with window watchdog, there is no closed window in standard watchdog mode. The standard watchdog receives a service signal at any time within the watchdog window. The watchdog fault occurs when not servicing watchdog during the watchdog window.

7.3.7.3 Watchdog Service Signal and Watchdog Fault Outputs (WD and WDO)

The watchdog service signal (WD) must stay high for at least 100 μ s. The WDO pin is the fault output terminal and is tied high through a pullup resistor to a regulated output supply. When a watchdog fault occurs, the devices momentarily pull WDO low for a duration of $t_{(WD_HOLD)}$.

$$t_{(WD_HOLD)} = 20\% \times t_{(WD)} \quad (12)$$

7.3.7.4 RO SC Status Detection (RO SC)

When a watchdog function is enabled, if the RO SC pin is shorted to GND or open, the watchdog output (WDO) pin remains low, indicating a fault status. If the watchdog function is disabled, RO SC pin status detection does not work.

7.3.7.5 Watchdog Enable (PG and $\overline{WD_EN}$)

When PG (power good) is high, an external microcontroller or a digital circuit can apply a high or low logic signal to the $\overline{WD_EN}$ pin to disable or enable the watchdog. A low input to this pin turns the watchdog on, and a high input turns the watchdog off. If PG is low, the watchdog is disabled and the watchdog-fault output (WDO) pin stays in the high-impedance state.

7.3.7.6 Watchdog Initialization

On power up and during normal operation, the watchdog initializes under the conditions shown in [Table 7-2](#).

Table 7-2. Conditions for Watchdog Initialization

EDGE	WHAT CAUSES THE WATCHDOG TO INITIALIZE
↑	Rising edge of PG (power good) while the watchdog is in the enabled state, for example, during soft power up
↓	Falling edge of $\overline{WD_EN}$ while PG is already high, for example, when the microprocessor enables the watchdog after the device is powered up
↑	Rising edge of WDO while PG is already high and the watchdog is in the enabled state, for example, right after a closed window is serviced

7.3.7.7 Window Watchdog Operation (WTS = Low)

The window watchdog is able to monitor whether the frequency of the watchdog service signal (WD) is within certain ranges. A watchdog low-voltage fault is reported when the frequency of the watchdog service signal is out of the setting range. Figure 7-4 shows the window watchdog initialization and operation for the TPS7B63xx-Q1 (WRS is low). After the output voltage is in regulation and PG is high, the window watchdog becomes enabled when an external signal pulls $\overline{\text{WD_EN}}$ (the watchdog enable pin) low. This causes the watchdog to initialize and wait for a service signal during the first initialization window for 8 times the duration of t_{WD} . A service signal applied to the WD pin during the initialization open window resets the watchdog counter and a closed window starts. To prevent a fault condition from occurring, watchdog service must not occur during the closed window. Watchdog service must occur during the following open window to prevent a fault condition from occurring. The fault output (WDO), externally pulled up to V_{OUT} (typical), stays high as long as the watchdog receives a proper service signal and there is no other fault condition.

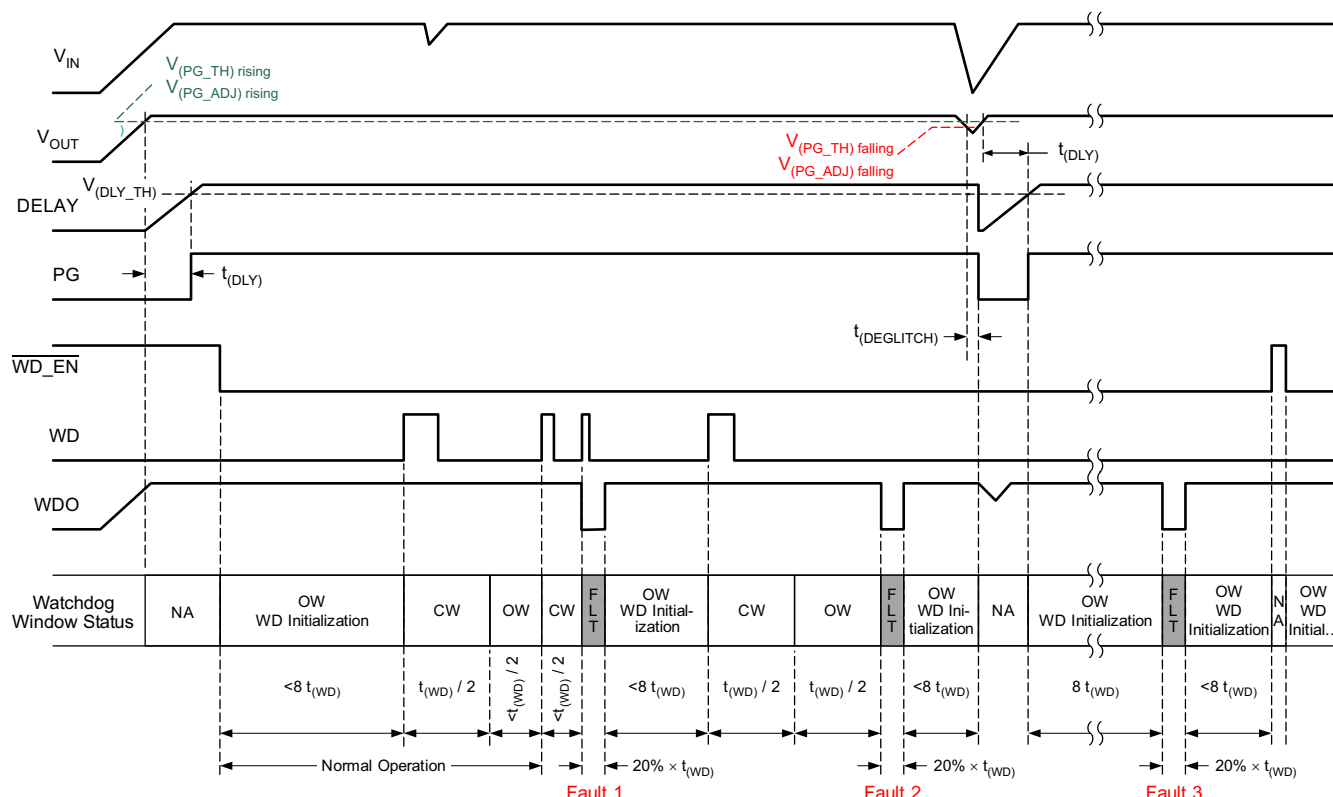

Figure 7-4. Window Watchdog Operation

Three different fault conditions occur in Figure 7-4:

- Fault 1: The watchdog service signal is received during the closed window. The WDO is triggered once, receiving a WD rising edge during the closed window.
- Fault 2: The watchdog service signal is not received during the open window. WDO is triggered after the maximum open-window duration $t_{\text{WD}} / 2$.
- Fault 3: The watchdog service signal is not received during the WD initialization. WDO is triggered after the maximum initialization window duration $8 \times t_{\text{WD}}$.

7.3.7.8 Standard Watchdog Operation (WTS = High)

The standard watchdog is able to monitor whether the frequency of the watchdog service signal (WD) is lower than a certain value. A watchdog low-voltage fault is reported when the frequency of the watchdog service signal is lower than the set value.

Figure 7-5 shows the standard watchdog initialization and operation for the TPS7B63xx-Q1. Similar to the window watchdog, after output the voltage is in regulation and PG asserts high, the standard watchdog becomes enabled when an external signal pulls WD_EN low. This causes the standard watchdog to initialize and wait for a service signal during the first initialization window for 8 times the duration of $t_{(WD)}$. A service signal applied to the WD pin during the first open window resets the watchdog counter and another open window starts. To prevent a fault condition from occurring, watchdog service must occur during the every open window to prevent a fault condition from occurring. The fault output (WDO), externally pulled up to V_{OUT} (typical), stays high as long as the watchdog receives proper service and there is not fault condition.

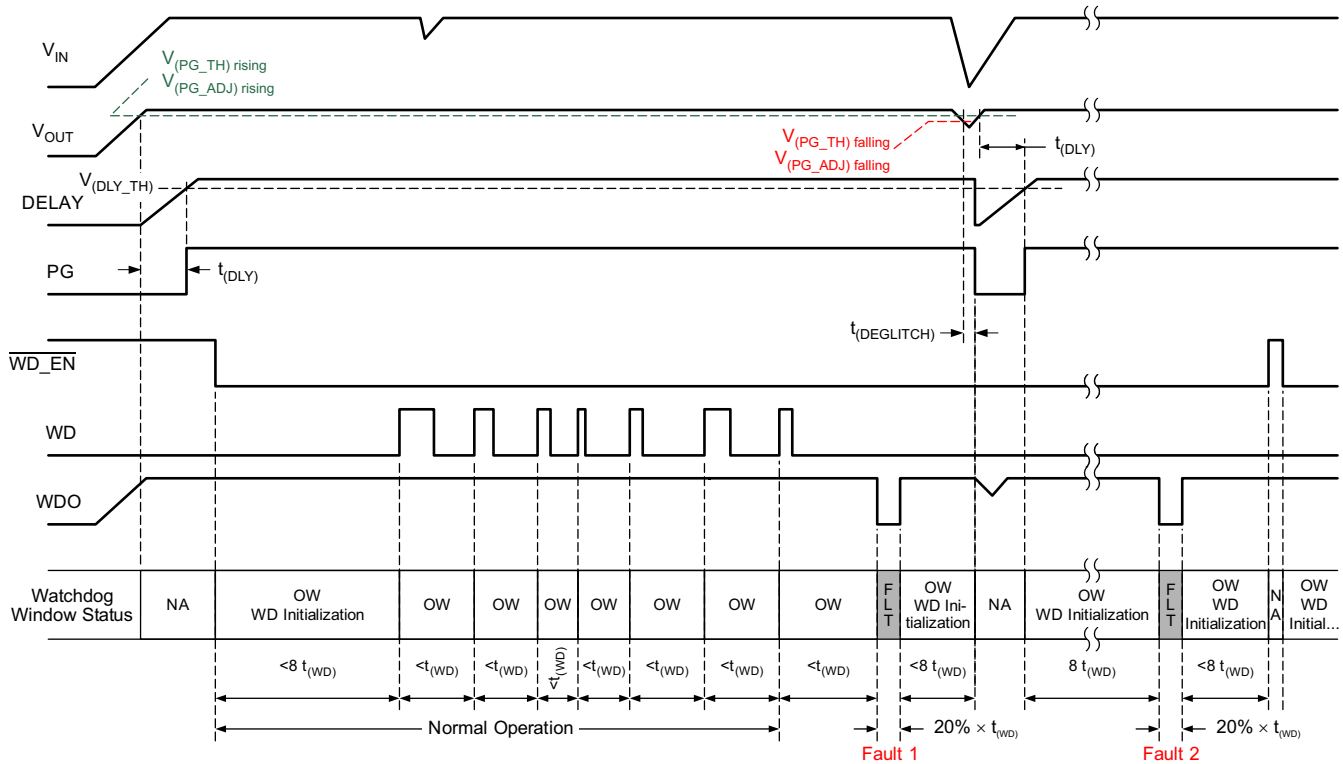

Figure 7-5. Standard Watchdog Operation

Two different fault conditions occur in Figure 7-5:

- Fault 1: The watchdog service signal is not received during the open window. WDO is triggered after the maximum open-window duration $t_{(WD)}$.
- Fault 2: The watchdog service signal is not received during the WD initialization. WDO is triggered after the maximum initialization window duration $8 \times t_{(WD)}$.

7.4 Device Functional Modes

7.4.1 Operation With Input Voltage Lower Than 4 V

The devices normally operate with input voltages above 4 V. The devices can also operate at lower input voltages; the maximum UVLO voltage is 2.6 V. At input voltages below the actual UVLO voltage, the devices do not operate.

7.4.2 Operation With Input Voltage Higher Than 4 V

When the input voltage is greater than 4 V, if the input voltage is higher than the output set value plus the device dropout voltage, then the output voltage is equal to the set value. Otherwise, the output voltage is equal to the input voltage minus the dropout voltage.

8 Application and Implementation

Note

Information in the following applications sections is not part of the TI component specification, and TI does not warrant its accuracy or completeness. TI's customers are responsible for determining suitability of components for their purposes, as well as validating and testing their design implementation to confirm system functionality.

8.1 Application Information

The TPS7B63xx-Q1 is a 300-mA low-dropout watchdog linear regulator with ultralow quiescent current. The PSpice transient model is available for download on the product folder and can be used to evaluate the basic function of the device.

8.2 Typical Application

Figure 8-1 shows a typical application circuit for the TPS7B63xx-Q1 device. Different values of external components can be used, depending on the end application. An application may require a larger output capacitor during fast load steps to prevent a large drop on the output voltage. TI recommends using a low-ESR ceramic capacitor with a dielectric of type X7R.

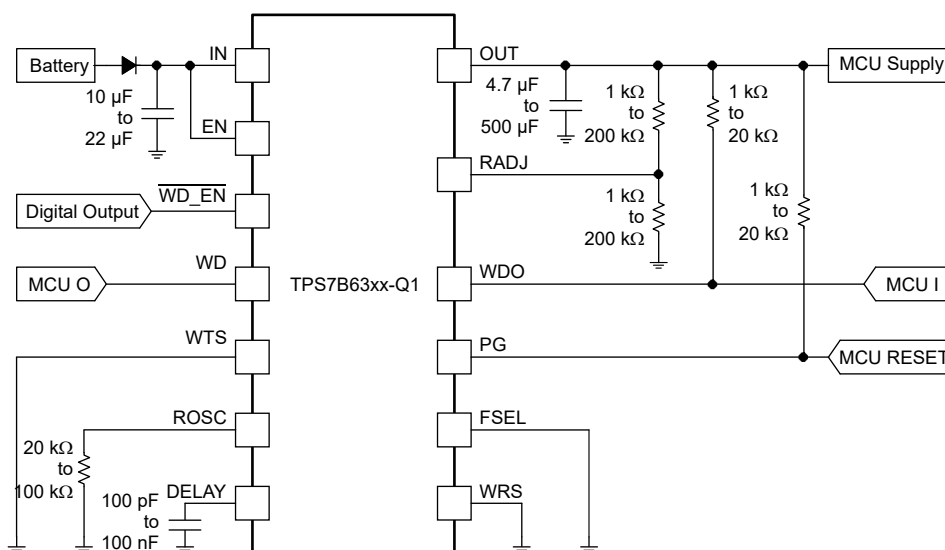

Figure 8-1. TPS7B63xx-Q1 Typical Application Schematic

8.2.1 Design Requirements

For this design example, use the parameters listed in [Table 8-1](#).

Table 8-1. Design Parameters

DESIGN PARAMETER	EXAMPLE VALUES
Input voltage range	4 V to 40 V for TPS7B6333-Q1 5.6 V to 40 V for TPS7B6350-Q1
Input capacitor range	10 μ F to 22 μ F
Output voltage	3.3 V, 5 V
Output current rating	300 mA maximum
Output capacitor range	4.7 μ F to 500 μ F
Power-good threshold	Adjustable or fixed
Power-good delay capacitor	100 pF to 100 nF
Watchdog type	Standard watchdog or window watchdog
Watchdog window periods	10 ms to 500 ms

8.2.2 Detailed Design Procedure

To begin the design process, determine the following:

- Input voltage range
- Output voltage
- Output current
- Power-good threshold
- Power-good delay capacitor
- Watchdog type
- Watchdog window period

8.2.2.1 Input Capacitor

When using a TPS7B63xx-Q1 device, TI recommends adding a 10- μ F to 22- μ F capacitor with a 0.1 μ F ceramic bypass capacitor in parallel at the input to keep the input voltage stable. The voltage rating must be greater than the maximum input voltage.

8.2.2.2 Output Capacitor

Ensuring the stability of the TPS7B63xx-Q1 device requires an output capacitor with a value in the range from 4.7 μ F to 500 μ F and with an ESR range from 0.001 Ω to 20 Ω . TI recommends selecting a ceramic capacitor with low ESR to improve the load transient response.

8.2.2.3 Power-Good Threshold

The power-good threshold is set by connecting PGADJ to GND or to a resistor divider from OUT to GND. The [Adjustable Power-Good Threshold \(PG, PGADJ\)](#) section provides the method for setup of the power-good threshold.

8.2.2.4 Power-Good Delay Period

The power-good delay period is set by an external capacitor (C_{DELAY}) to ground, with a typical capacitor value from 100 pF to 100 nF. Calculate the correct capacitance for the application using [Equation 2](#).

8.2.2.5 Watchdog Setup

The [Integrated Watchdog](#) section discusses the watchdog type selection and watchdog window-period setup method.

8.2.3 Application Curves

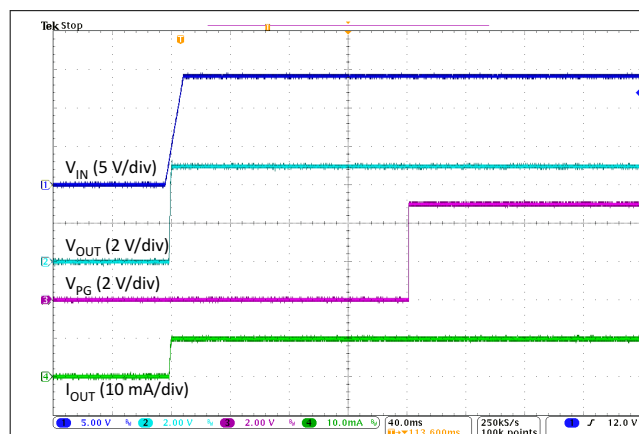

Figure 8-2. TPS7B6350-Q1 Power-Up Waveform

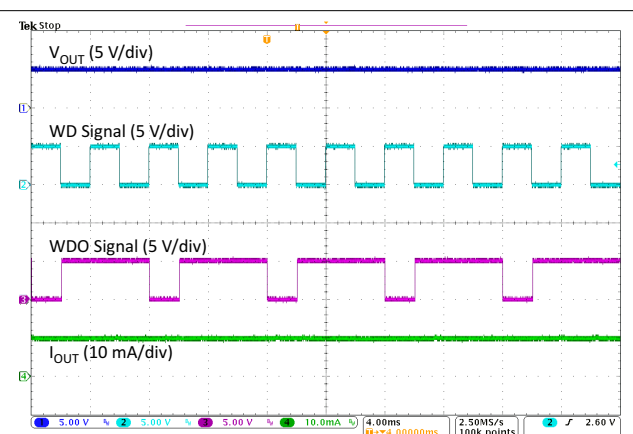

Figure 8-3. TPS7B6350-Q1 Watchdog Fault (High-Frequency Watchdog Service Signal)

8.3 Power Supply Recommendations

The device is designed to operate from an input-voltage supply range from 4 V to 40 V. This input supply must be well regulated. If the input supply is located more than a few inches from the TPS7B63xx-Q1 device, TI recommends adding a capacitor with a value of $\geq 10 \mu\text{F}$ with a $0.1 \mu\text{F}$ ceramic bypass capacitor in parallel at the input.

8.4 Layout

8.4.1 Layout Guidelines

For LDO power supplies, especially high-voltage and high-current ones, layout is an important step. If layout is not carefully designed, the regulator could not deliver enough output current because of thermal limitation. To improve the thermal performance of the device and maximize the current output at high ambient temperature, TI recommends spreading the thermal pad as much as possible and putting enough thermal vias on the thermal pad. Figure 8-4 shows an example layout.

8.4.2 Layout Example

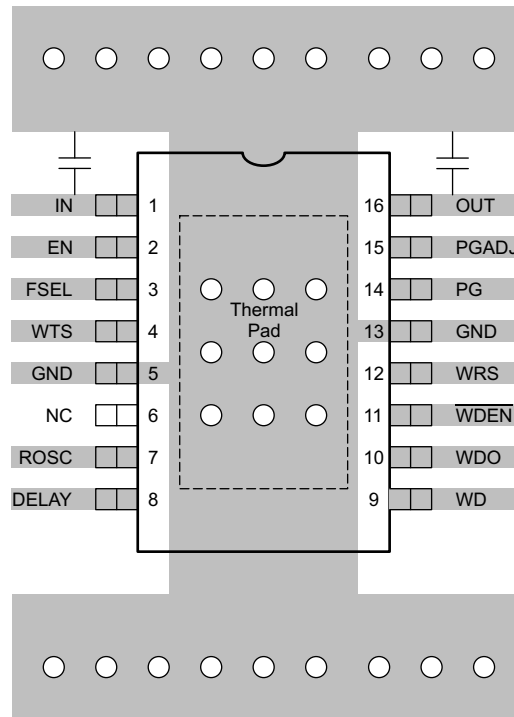

Figure 8-4. Layout Recommendation

9 Device and Documentation Support

9.1 Documentation Support

9.1.1 Related Documentation

For related documentation see the following:

Texas Instruments, [TPS7B63xx-Q1 Evaluation Module user's guide](#)

9.2 Receiving Notification of Documentation Updates

To receive notification of documentation updates, navigate to the device product folder on [ti.com](#). Click on *Subscribe to updates* to register and receive a weekly digest of any product information that has changed. For change details, review the revision history included in any revised document.

9.3 Support Resources

[TI E2E™ support forums](#) are an engineer's go-to source for fast, verified answers and design help — straight from the experts. Search existing answers or ask your own question to get the quick design help you need.

Linked content is provided "AS IS" by the respective contributors. They do not constitute TI specifications and do not necessarily reflect TI's views; see TI's [Terms of Use](#).

9.4 Trademarks

PowerPAD™ and TI E2E™ are trademarks of Texas Instruments.

All trademarks are the property of their respective owners.

9.5 Electrostatic Discharge Caution



This integrated circuit can be damaged by ESD. Texas Instruments recommends that all integrated circuits be handled with appropriate precautions. Failure to observe proper handling and installation procedures can cause damage.

ESD damage can range from subtle performance degradation to complete device failure. Precision integrated circuits may be more susceptible to damage because very small parametric changes could cause the device not to meet its published specifications.

9.6 Glossary

[TI Glossary](#) This glossary lists and explains terms, acronyms, and definitions.

10 Mechanical, Packaging, and Orderable Information

The following pages include mechanical, packaging, and orderable information. This information is the most-current data available for the designated devices. This data is subject to change without notice and without revision of this document. For browser-based versions of this data sheet, see the left-hand navigation pane.

PACKAGING INFORMATION

Orderable Device	Status (1)	Package Type	Package Drawing	Pins	Package Qty	Eco Plan (2)	Lead finish/ Ball material (6)	MSL Peak Temp (3)	Op Temp (°C)	Device Marking (4/5)	Samples
TPS7B6333QPWPRQ1	ACTIVE	HTSSOP	PWP	16	2000	RoHS & Green	NIPDAU	Level-3-260C-168 HR	-40 to 125	7B6333Q	Samples
TPS7B6350QPWPRQ1	ACTIVE	HTSSOP	PWP	16	2000	RoHS & Green	NIPDAU	Level-3-260C-168 HR	-40 to 125	7B6350Q	Samples

(1) The marketing status values are defined as follows:

ACTIVE: Product device recommended for new designs.

LIFEBUY: TI has announced that the device will be discontinued, and a lifetime-buy period is in effect.

NRND: Not recommended for new designs. Device is in production to support existing customers, but TI does not recommend using this part in a new design.

PREVIEW: Device has been announced but is not in production. Samples may or may not be available.

OBSOLETE: TI has discontinued the production of the device.

(2) **RoHS:** TI defines "RoHS" to mean semiconductor products that are compliant with the current EU RoHS requirements for all 10 RoHS substances, including the requirement that RoHS substance do not exceed 0.1% by weight in homogeneous materials. Where designed to be soldered at high temperatures, "RoHS" products are suitable for use in specified lead-free processes. TI may reference these types of products as "Pb-Free".

RoHS Exempt: TI defines "RoHS Exempt" to mean products that contain lead but are compliant with EU RoHS pursuant to a specific EU RoHS exemption.

Green: TI defines "Green" to mean the content of Chlorine (Cl) and Bromine (Br) based flame retardants meet JS709B low halogen requirements of <=1000ppm threshold. Antimony trioxide based flame retardants must also meet the <=1000ppm threshold requirement.

(3) MSL, Peak Temp. - The Moisture Sensitivity Level rating according to the JEDEC industry standard classifications, and peak solder temperature.

(4) There may be additional marking, which relates to the logo, the lot trace code information, or the environmental category on the device.

(5) Multiple Device Markings will be inside parentheses. Only one Device Marking contained in parentheses and separated by a "~" will appear on a device. If a line is indented then it is a continuation of the previous line and the two combined represent the entire Device Marking for that device.

(6) Lead finish/Ball material - Orderable Devices may have multiple material finish options. Finish options are separated by a vertical ruled line. Lead finish/Ball material values may wrap to two lines if the finish value exceeds the maximum column width.

Important Information and Disclaimer:The information provided on this page represents TI's knowledge and belief as of the date that it is provided. TI bases its knowledge and belief on information provided by third parties, and makes no representation or warranty as to the accuracy of such information. Efforts are underway to better integrate information from third parties. TI has taken and continues to take reasonable steps to provide representative and accurate information but may not have conducted destructive testing or chemical analysis on incoming materials and chemicals. TI and TI suppliers consider certain information to be proprietary, and thus CAS numbers and other limited information may not be available for release.

In no event shall TI's liability arising out of such information exceed the total purchase price of the TI part(s) at issue in this document sold by TI to Customer on an annual basis.

TAPE AND REEL INFORMATION



QUADRANT ASSIGNMENTS FOR PIN 1 ORIENTATION IN TAPE



*All dimensions are nominal

Device	Package Type	Package Drawing	Pins	SPQ	Reel Diameter (mm)	Reel Width W1 (mm)	A0 (mm)	B0 (mm)	K0 (mm)	P1 (mm)	W (mm)	Pin1 Quadrant
TPS7B6333QPWPRQ1	HTSSOP	PWP	16	2000	330.0	12.4	6.9	5.6	1.6	8.0	12.0	Q1
TPS7B6350QPWPRQ1	HTSSOP	PWP	16	2000	330.0	12.4	6.9	5.6	1.6	8.0	12.0	Q1

TAPE AND REEL BOX DIMENSIONS

*All dimensions are nominal

Device	Package Type	Package Drawing	Pins	SPQ	Length (mm)	Width (mm)	Height (mm)
TPS7B6333QPWRQ1	HTSSOP	PWP	16	2000	350.0	350.0	43.0
TPS7B6350QPWRQ1	HTSSOP	PWP	16	2000	350.0	350.0	43.0

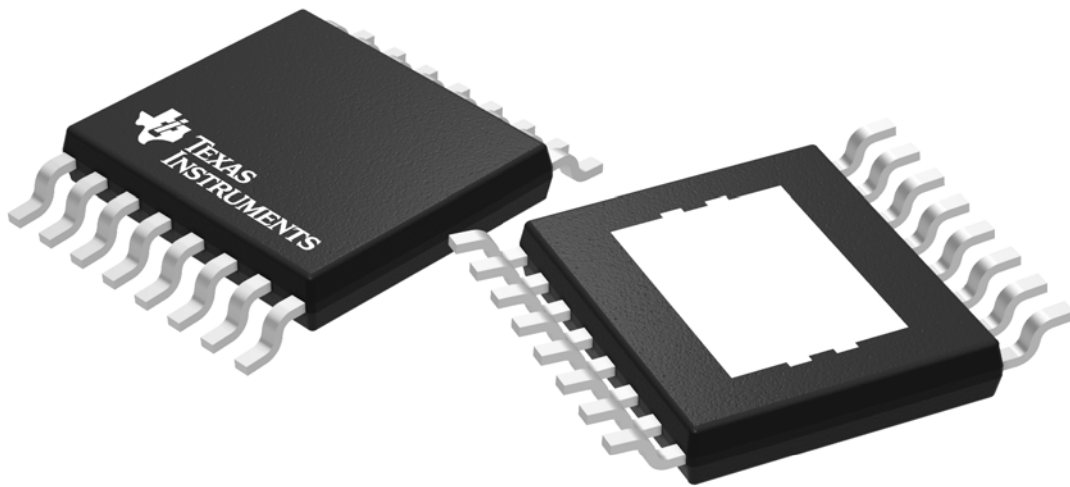

Images above are just a representation of the package family, actual package may vary.
Refer to the product data sheet for package details.

EXAMPLE STENCIL DESIGN

PWP0016J

PowerPAD™ TSSOP - 1.2 mm max height

SMALL OUTLINE PACKAGE

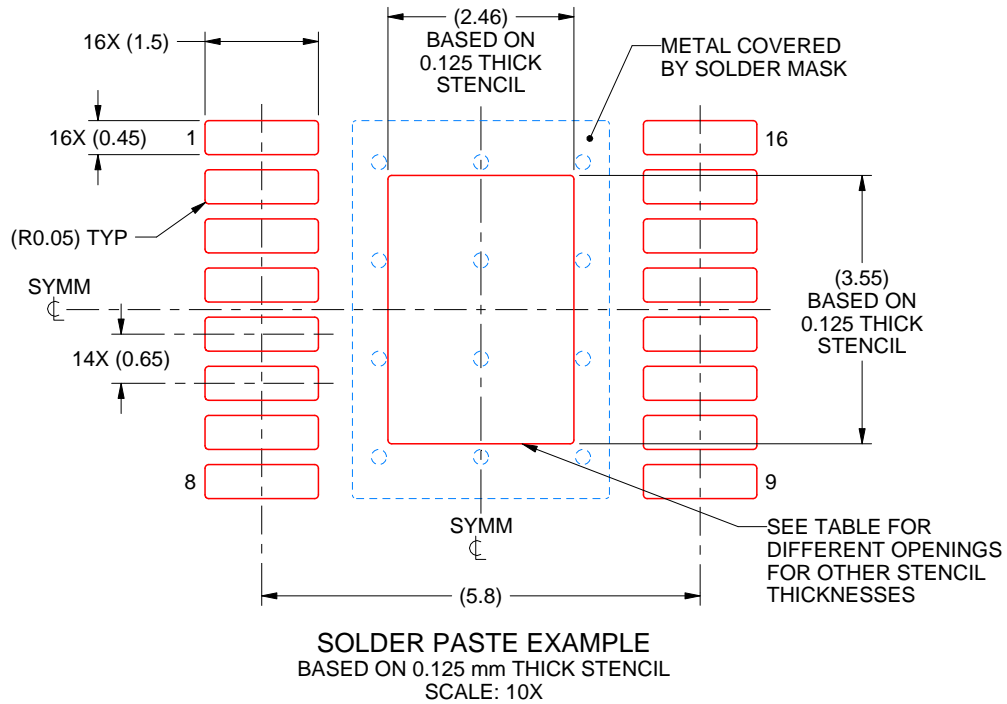

STENCIL THICKNESS	SOLDER STENCIL OPENING
0.1	2.75 X 3.97
0.125	2.46 X 3.55 (SHOWN)
0.15	2.25 X 3.24
0.175	2.08 X 3.00

4223595/A 03/2017

NOTES: (continued)

10. Laser cutting apertures with trapezoidal walls and rounded corners may offer better paste release. IPC-7525 may have alternate design recommendations.
11. Board assembly site may have different recommendations for stencil design.

IMPORTANT NOTICE AND DISCLAIMER

TI PROVIDES TECHNICAL AND RELIABILITY DATA (INCLUDING DATA SHEETS), DESIGN RESOURCES (INCLUDING REFERENCE DESIGNS), APPLICATION OR OTHER DESIGN ADVICE, WEB TOOLS, SAFETY INFORMATION, AND OTHER RESOURCES "AS IS" AND WITH ALL FAULTS, AND DISCLAIMS ALL WARRANTIES, EXPRESS AND IMPLIED, INCLUDING WITHOUT LIMITATION ANY IMPLIED WARRANTIES OF MERCHANTABILITY, FITNESS FOR A PARTICULAR PURPOSE OR NON-INFRINGEMENT OF THIRD PARTY INTELLECTUAL PROPERTY RIGHTS.

These resources are intended for skilled developers designing with TI products. You are solely responsible for (1) selecting the appropriate TI products for your application, (2) designing, validating and testing your application, and (3) ensuring your application meets applicable standards, and any other safety, security, regulatory or other requirements.

These resources are subject to change without notice. TI grants you permission to use these resources only for development of an application that uses the TI products described in the resource. Other reproduction and display of these resources is prohibited. No license is granted to any other TI intellectual property right or to any third party intellectual property right. TI disclaims responsibility for, and you will fully indemnify TI and its representatives against, any claims, damages, costs, losses, and liabilities arising out of your use of these resources.

TI's products are provided subject to [TI's Terms of Sale](#) or other applicable terms available either on [ti.com](https://www.ti.com) or provided in conjunction with such TI products. TI's provision of these resources does not expand or otherwise alter TI's applicable warranties or warranty disclaimers for TI products.

TI objects to and rejects any additional or different terms you may have proposed.

Mailing Address: Texas Instruments, Post Office Box 655303, Dallas, Texas 75265
Copyright © 2024, Texas Instruments Incorporated

Looking for pricing, stock, or lifecycle information?

Click below to explore more details on WIN SOURCE:

- ⊖ [View STP26N65DM2 on WIN SOURCE](#)
- ⊖ [STMicroelectronics Information](#)

Optimize Your Supply Chain with WIN SOURCE Solutions

- ✓ Global Sourcing Solution
- ✓ Obsolete Management
- ✓ Cost Control Management
- ✓ Shortage Management
- ✓ Alternative Solution
- ✓ Excess Inventory Management