



**THE DATASHEET OF  
TEA1720BT/1J**





# TEA1720BT

GreenChip SMPS low power control IC

Rev. 2 — 7 March 2014

Product data sheet

## 1. General description

The TEA1720BT is a small and low cost Switched Mode Power Supply (SMPS) controller IC for low power applications (up to 12.5 W) and operates directly from the rectified universal mains input. The device includes an emitter switch for driving an external low-cost bipolar power transistor. It has been optimized for flyback converter topologies to provide high-efficiency over the entire load range with ultra-low power consumption in the no-load condition. It provides a circuit for fast start-up directly from the rectified mains voltage without any external bleeder circuits.

The converter operates as a regulated voltage source from no-load up to the maximum output current and operates as current source that delivers the maximum current over a broad output voltage range. Using the TEA1720BT a low power converter can be built at minimum cost and with the minimum number of external components.

The controller regulates the output voltage with primary-side sensing which eliminates the need for an additional secondary feedback circuitry and simplifies the design. At higher power levels, a frequency and current control mode is used. It operates with Burst mode control at low power levels and no-load condition. The burst mode minimizes audible noise and provides an energy save state which reduces the power consumption in no-load condition. The Burst mode frequency of 400 Hz enables no-load power consumption < 20 mW at high mains input.

A fast transient response is obtained when the TEA1720BT is used in combination with the TEA1705 transient controller at the secondary side. The fast transient response ensures excellent control of the output voltage at load steps, at minimum no load power and at small output capacitors.

## 2. Features and benefits

### 2.1 Power features

- Low power SMPS controller designed for charger applications up to 12.5 W
- Primary sensing for control of the output voltage without optocoupler and secondary feedback circuitry
- Minimizes audible noise in all operation modes
- USB battery charging and Energy Star 2.0 compliant
- Jitter function for reduced EMI
- Fast transient response when TEA1720BT is used with the TEA1705 transient controller at the secondary side
- Integrated emitter switch to control external low-cost bipolar power transistor



## 2.2 Green features

- Enables no-load power consumption < 20 mW
- Very low supply current in no-load condition with energy save mode
- Incorporates a high voltage start-up circuit with zero current consumption under normal switching operation
- Available in halogen-free and Restriction of Hazardous Substances (RoHS) SO8 package

## 2.3 Protection features

- OverVoltage Protection (OVP) on feedback control pin (FB) with safe restart
- UnderVoltage LockOut (UVLO) on IC supply pin
- OverTemperature Protection (OTP)
- Soft-start by reduced peak current for zero and low output voltage
- Demagnetization protection for guaranteed discontinuous conduction mode operation
- Open and short-circuit protection of the Feedback control (FB) pin
- Short-circuit protection of the charger output

## 3. Applications

- Battery chargers for smart phones and media tablets up to 12.5 W
- Standby supply for TV and desktop PC

## 4. Quick reference data

Table 1. Quick reference data

Symbol	Parameter	Conditions	Min	Typ	Max	Unit
<b>Power switch (pin EMITTER)</b>						
$R_{on}$	on-state resistance	emitter switch; $I_{ds} = 100 \text{ mA}$ ; $T_j = 25 \text{ }^\circ\text{C}$	0.75	0.85	1.0	$\Omega$
<b>Oscillator (pins EMITTER and SENSE)</b>						
$f_{burst}$	burst mode frequency	burst frequency in CVB mode, without jitter	350	400	450	Hz
$f_{osc(high)}$	HIGH oscillator frequency	maximum switching frequency in CV and CC mode, without jitter	46	52	58	kHz
<b>Supply (pin VCC)</b>						
$V_{CC(startup)}$	start-up supply voltage		15	17	19	V
$V_{CC(stop)}$	stop supply voltage	undervoltage lockout of IC	7.5	8.5	9.5	V

## 5. Ordering information

Table 2. Ordering information

Type number	Package		Version
	Name	Description	
TEA1720BT/1	SO8	plastic small outline package; 8 leads; body width 3.9 mm	SOT96-1

## 6. Block diagram

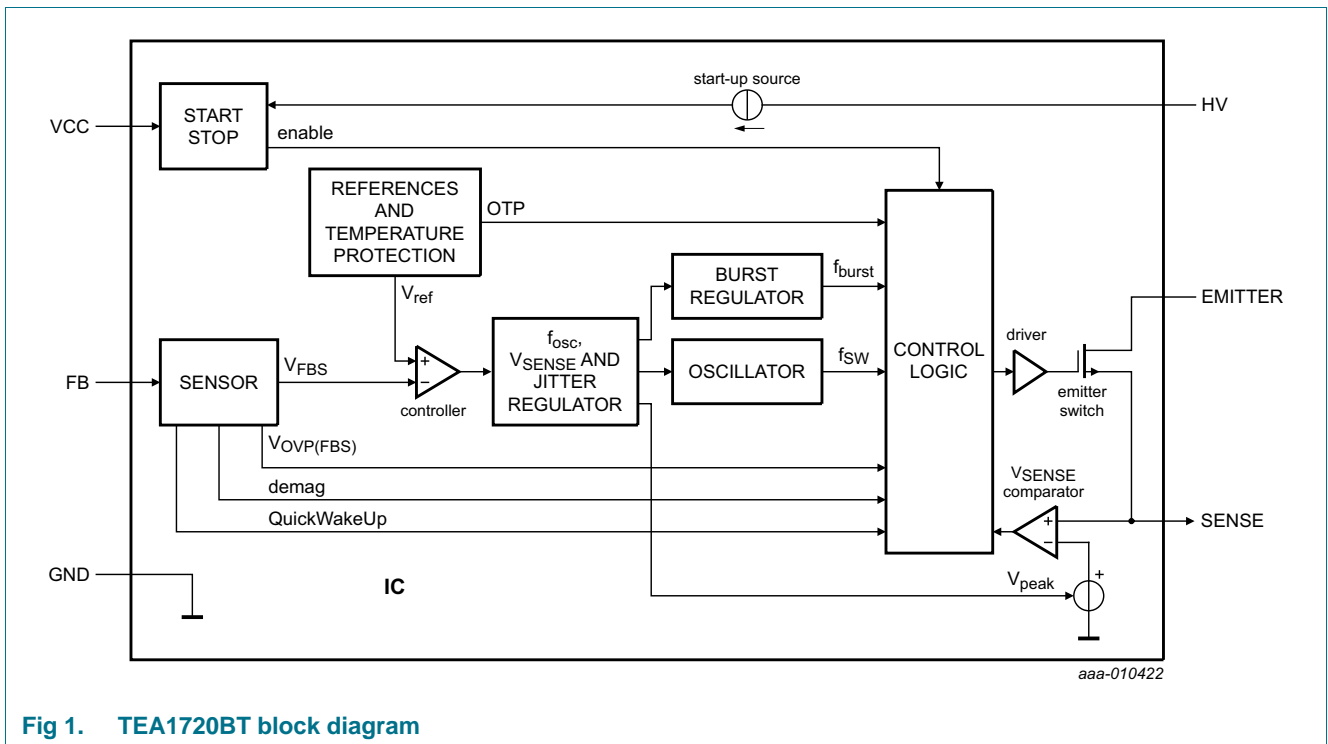

Fig 1. TEA1720BT block diagram

## 7. Pinning information

### 7.1 Pinning

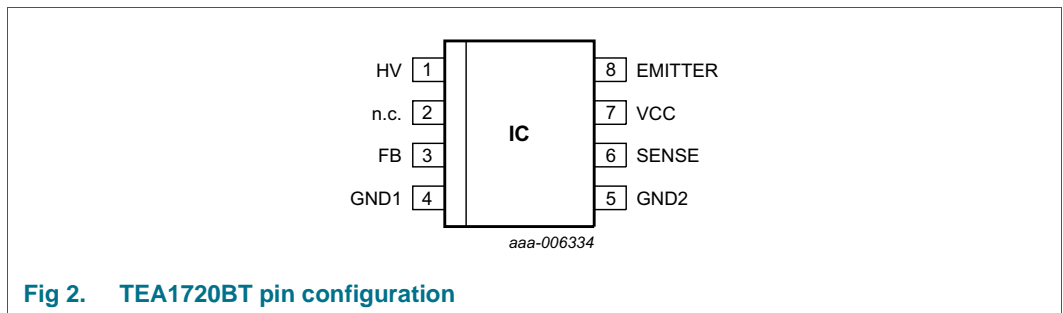

Fig 2. TEA1720BT pin configuration

## 7.2 Pin description

Table 3. Pin description

Pin	Pin name	I/O type	Description
1	HV	I	high-voltage start-up
2	n.c.	-	not connected; high-voltage spacer
3	FB	I	feedback input for voltage sensing
4	GND1	-	ground
5	GND2	-	ground
6	SENSE	I	source emitter switch and sense input
7	VCC	I	supply input
8	EMITTER	I	emitter connection of external NPN power transistor

## 8. Functional description

### 8.1 Start-up

The TEA1720BT starts up by charging the VCC capacitor until the  $V_{CC(\text{startup})}$  level. The charging current flows from the HV pin via an internal start-up current source to the VCC pin.

Once the start-up level has been reached the start-up current source is switched off. During the switching operation, the start-up current source remains current-less and has zero bleeder loss.

### 8.2 Primary sensing

The FB input senses the reflected secondary voltage on the primary side. The FB input has a sample and hold function that samples the FB voltage on the secondary stroke to control the output voltage.

The sampled  $V_{FBS}$  voltage is the input for the TEA1720BT's control loop and defines the operating mode.

### 8.3 Operating modes

The TEA1720BT operates in three modes, one of which is active at the time. The three modes in order of decreasing load impedance are:

- CVB: Constant Voltage with Burst mode
- CV: Constant Voltage mode
- CC: Constant Current mode

The converter acts as a voltage source in CVB and CV modes.

The converter acts as a current source in CC mode.

#### 8.3.1 Constant Voltage with Burst mode (CVB)

At low power, the TEA1720BT operates in Burst mode.

Burst mode operates with a  $V_{\text{ref-peak}} = 120$  mV, a switching frequency of 23 kHz and burst duty cycle regulation by sensing the FB voltage.

The TEA1720BT features an energy save function that puts the main part of the analogue blocks in a sleep mode with low supply current in burst mode. The burst mode enables the energy save mode in the non-switching part of the burst. The IC switches to the nominal supply just before new burst starts.

Transition from burst mode to CV mode happens at 100 % burst duty cycle: a burst completely filled with 32 pulses. This 100 % pulse train is identical to the lowest power level of the CV mode. The TEA1720BT changes directly from burst mode to CV mode if the FB voltage drops below 2.4 V in burst mode.

### 8.3.2 Constant Voltage mode (CV)

At higher power levels, the TEA1720BT operates in CV mode. The output voltage is sensed by the FB pin and the control keeps the output voltage constant over the power range.

CV mode starts at 23 kHz switching frequency and peak current regulation at the  $V_{\text{ref-peak}}$  minimum level of 120 mV.

With an increasing power output, the  $V_{\text{ref-peak}}$  level and the switching frequency are also increased.

CV mode is exited when the maximum power level is reached. Maximum power occurs at peak current regulation at the  $V_{\text{ref-peak}}$  maximum level of 575 mV and a maximum switching frequency of 52 kHz.

### 8.3.3 Constant Current mode (CC)

The CC mode starts at maximum power delivery and keeps the output current constant for decreasing output voltage.

CC mode is enabled when the converter is operating at the maximum switching frequency, with the maximum primary peak current when the FB voltage drops below the regulated level.

Regulation of the switching frequency from 52 kHz down to 23 kHz controls the CC mode operation.

## 8.4 Jitter

The TEA1720BT features a jitter function for ElectroMagnetic Interference (EMI) reduction. The switching frequency is 7 % typical for the spread spectrum. The sweep frequency is a low frequency of approximately 220 Hz. To keep the output power constant, the  $V_{\text{SENSE}}$  level is jittered with the opposite polarity. The jitter is active in all operation modes except burst mode.

## 8.5 Fast transient response

In combination with the TEA1705 transient controller at the secondary side the TEA1720BT can achieve a fast transient response on load steps.

In the Energy save state the TEA1720BT monitors the FB pin. When the device detects a load step a signal is submitted through the transformer that pulls the FB pin below the  $-0.5\text{ V}$  threshold.

The TEA1720BT wakes up quickly and reacts with the maximum peak current and the switching frequency to keep the drop of the output voltage to its minimum. The device's reaction allows the smallest size output capacitor.

### 8.6 Short pin SENSE protection

The TEA1720BT has an integrated protection against faults caused by a shorted SENSE pin or a shorted sense resistor. During every primary stroke, the voltage on the SENSE pin is monitored. In normal situations, the voltage on the SENSE pin reaches the sense protection trigger level after the sense protection time has passed. When the SENSE voltage does not reach this level, the SENSE pin is shorted and the protection is activated. The IC stops switching and restarts. The value of the sense protection time is automatically adapted to the mains input voltage.

### 8.7 Hiccup mode protection

The hiccup mode protects the power supply from damage in case of current overload situations. The output voltage is sensed via the FB pin. If the voltage on the FB pin drops below the  $V_{th(hiccup)}$  level for a time exceeding  $t_{blank(hiccup)}$ , the TEA1720BT stops switching and restarts. As long as the fault condition is present the IC makes repetitive restart attempts. Once the fault condition is removed, normal operation is resumed.

### 8.8 OverTemperature Protection (OTP)

The IC incorporates an accurate internal temperature protection. When the junction temperature exceeds the overtemperature protection threshold temperature, the IC stops switching. Once the temperature has dropped with the overtemperature protection temperature hysteresis ( $T < T_{pl(IC)} - T_{pl(IC)hys}$ ), the IC restarts.

## 9. Limiting values

**Table 4. Limiting values**

In accordance with the Absolute Maximum Rating System (IEC 60134).

Symbol	Parameter	Conditions	Min	Max	Unit
<b>General</b>					
$T_{amb}$	ambient temperature		-40	+85	°C
$T_j$	junction temperature		-40	+160	°C
$T_{stg}$	storage temperature		-55	+150	°C
$V_{ESD}$	electrostatic discharge voltage	CDM; all pins	-500	+500	V
		HBM; all pins <a href="#">[1]</a>	-2000	+2000	V
<b>Voltages</b>					
$V_{HV}$	voltage on pin HV		-0.3	+550	V
$V_{SENSE}$	voltage on pin SENSE		-0.3	+5	V
$V_{CC}$	supply voltage		-0.3	+40	V
$V_{EMITTER}$	voltage on pin EMITTER		-0.3	+40	V

**Table 4. Limiting values ...continued**

In accordance with the Absolute Maximum Rating System (IEC 60134).

Symbol	Parameter	Conditions	Min	Max	Unit
$V_{FB}$	voltage on pin FB		-20	+5	V
<b>Currents</b>					
$I_{EMITTER}$	current on pin EMITTER		-1.1	1.1	A
$I_{SENSE}$	current on pin SENSE		-1.1	1.1	A

[1] Human body model: equivalent to discharging a 100 pF capacitor through a 1.5 k $\Omega$  series resistor.

## 10. Thermal characteristics

**Table 5. Thermal characteristics**

Symbol	Parameter	Conditions	Typ	Unit
$R_{th(j-a)}$	thermal resistance from junction to ambient	in free air; JEDEC test board	150	K/W
		in free air; on open PCB of 2.2 cm $\times$ 2.6 cm; 2-layer; 35 $\mu$ m Cu	200	K/W

## 11. Characteristics

**Table 6. Characteristics**

$V_{CC} = 20$  V;  $FB = 0$  V;  $R_{source} = 0.75$   $\Omega$ ;  $T_j = 25$   $^{\circ}$ C; all voltages referenced to GND; positive currents flow into the IC, unless otherwise specified.

Symbol	Parameter	Conditions	Min	Typ	Max	Unit
<b>Supply (pin VCC)</b>						
$I_{CC(startup)}$	start-up supply current	$V_{CC} = 0$ V	-1.5	-1.2	-0.9	mA
$I_{CC(startup)}$	start-up supply current	$V_{CC} = V_{CC(startup)} - 1$	-1.3	-1.0	-0.7	mA
$I_{CC}$	supply current	$V_{FB} = 2.8$ V; non-switching; in energy save	130	170	210	$\mu$ A
		CC mode	0.6	0.8	1.0	mA
$V_{CC(startup)}$	start-up supply voltage		15	17	19	V
$V_{CC(stop)}$	stop supply voltage	undervoltage lockout of IC	7.5	8.5	9.5	V
$T_{pl(IC)}$	IC protection level temperature		140	150	160	$^{\circ}$ C
$T_{pl(IC)hys}$	hysteresis of IC protection level temperature		-	50	-	$^{\circ}$ C
<b>Feedback (pin FB)</b>						
$V_{th(ovp)FB}$	overvoltage protection threshold voltage on pin FB		3.1	3.2	3.3	V
$V_{ref(FB)}$	reference voltage on pin FB	CV mode	2.45	2.5	2.55	V
$V_{th(FB)}$	threshold voltage on pin FB	transition from burst mode to constant voltage	2.35	2.4	2.45	V
$V_{det(demag)FB}$	demagnetization detection voltage on FB pin		25	50	75	mV

**Table 6. Characteristics ...continued**

$V_{CC} = 20\text{ V}$ ;  $FB = 0\text{ V}$ ;  $R_{source} = 0.75\ \Omega$ ;  $T_j = 25\text{ }^\circ\text{C}$ ; all voltages referenced to GND; positive currents flow into the IC, unless otherwise specified.

Symbol	Parameter	Conditions	Min	Typ	Max	Unit
$V_{det(trt)FB}$	transient detection voltage on pin FB	in energy save state	-0.6	-0.5	-0.4	V
$t_d(s)$	sample delay time	moment of sampling $V_{FB}$ after start of secondary stroke; $V_{FB} = 2.35\text{ V}$	4.4	5.4	6.4	$\mu\text{s}$
<b>Oscillator (pins EMITTER and SENSE)</b>						
$f_{burst}$	burst mode frequency	burst frequency in CVB mode, without jitter	350	400	450	Hz
$f_{jit}/f_{sw}$	jitter frequency to switching frequency ratio	in all operation modes except in CVB mode	5	7	9	%
$f_{osc(high)}$	high oscillator frequency	maximum switching frequency in CV and CC mode, without jitter	46	52	58	kHz
$f_{osc(low)}$	low oscillator frequency	minimum switching frequency in CV and CC mode, without jitter. switching frequency in CVB mode	20	23	26	kHz
$f_{mod}$	modulation frequency	in current source operation	170	220	270	Hz
$\delta_{max}$	maximum duty cycle		72	75	78	%
<b>HV start-up (pin HV)</b>						
$I_{off(HV)}$	off-state current on pin HV	$V_{HV} = 325\text{ V}$	-	1	-	$\mu\text{A}$
<b>Emitter switch (pin EMITTER)</b>						
$R_{on}$	on-state resistance	$I_{ds} = 100\text{ mA}$	0.75	0.85	1.0	$\Omega$
<b>Peak current comparator (pin SENSE)</b>						
$t_{PD}$	propagation delay	$dV/dt = 0.2\text{ V}/\mu\text{s}$	-	100	-	ns
$t_{leb}$	leading edge blanking time		270	320	370	ns
$V_{sense(high)}$	high sense voltage	maximum peak voltage in CV and CC modes, without jitter; $V_{FB} = -10\text{ V}$	540	575	610	mV
$V_{sense(low)}$	low sense voltage	CVB mode; $V_{FB} = -10\text{ V}$	100	120	140	mV
$V_{sense}^2 f_{osc}$	square sense voltage times oscillator frequency	$V_{sense(high)}^2 * f_{osc(high)}$ ; in CV and CC modes, without jitter; $V_{FB} = -10\text{ V}$	15.8	17.0	18.2	$\text{V}^2\text{kHz}$
<b>Sense pin short protection (pin SENSE)</b>						
$V_{scp(high)}$	high short-circuit protection voltage		-	125	-	mV
$V_{scp(low)}$	low short-circuit protection voltage on pin SENSE		-	105	-	mV
$t_{blank(scp)SENSE}$	short-circuit protection blanking time on pin SENSE	$V_{FB} = -10\text{ V}$	1	1.35	1.7	$\mu\text{s}$
<b>Hiccup protection (pin FB)</b>						
$V_{th(hiccup)}$	hiccup release threshold voltage		1.0	1.1	1.2	V
$V_{th(rel)(hiccup)}$	hiccup release voltage		1.3	1.4	1.5	V
$t_{blank(hiccup)}$	hiccup blanking time	at minimum switching frequency	15	21	27	ms

12. Application information

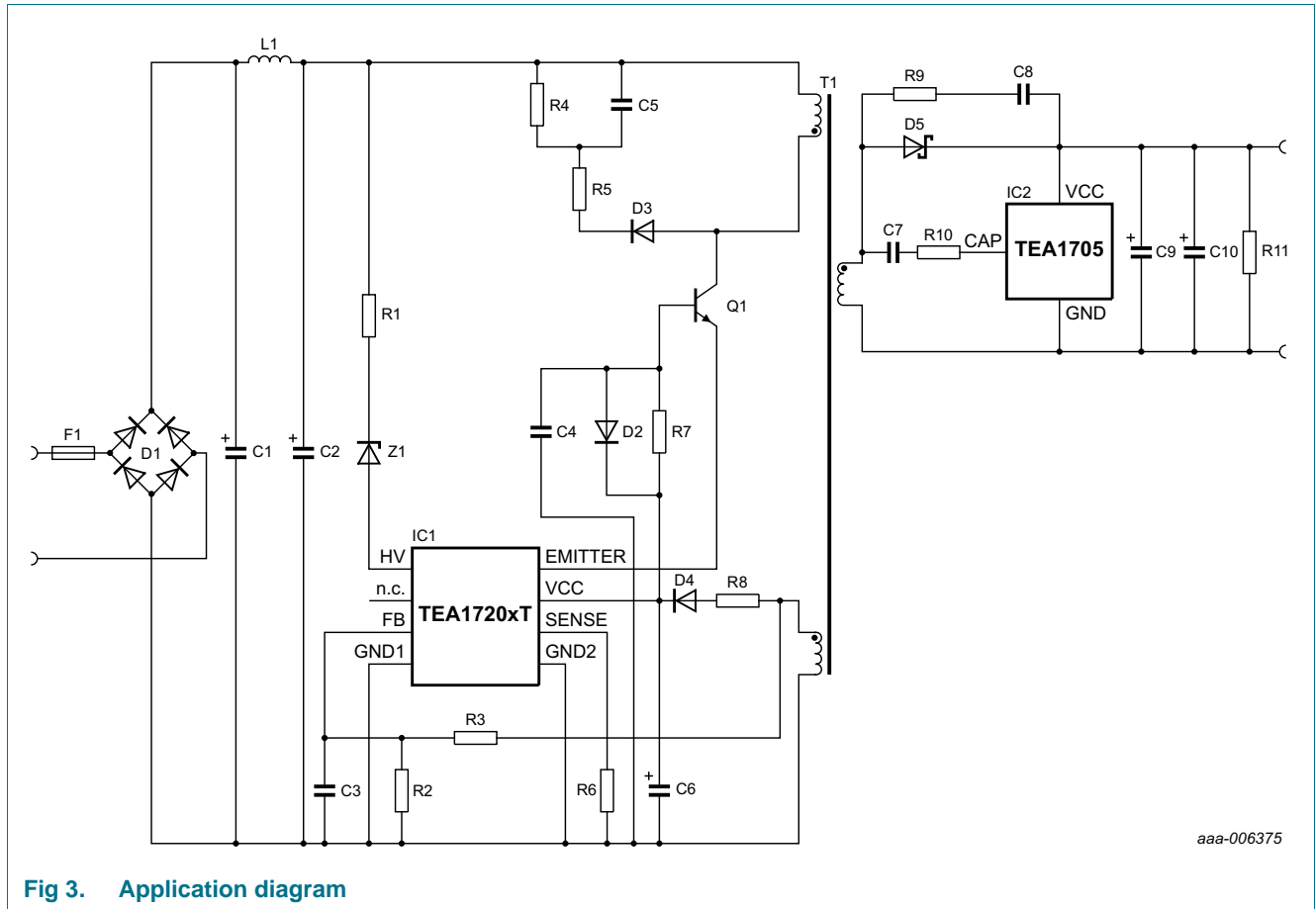

Fig 3. Application diagram

13. Package outline

SO8: plastic small outline package; 8 leads; body width 3.9 mm

SOT96-1

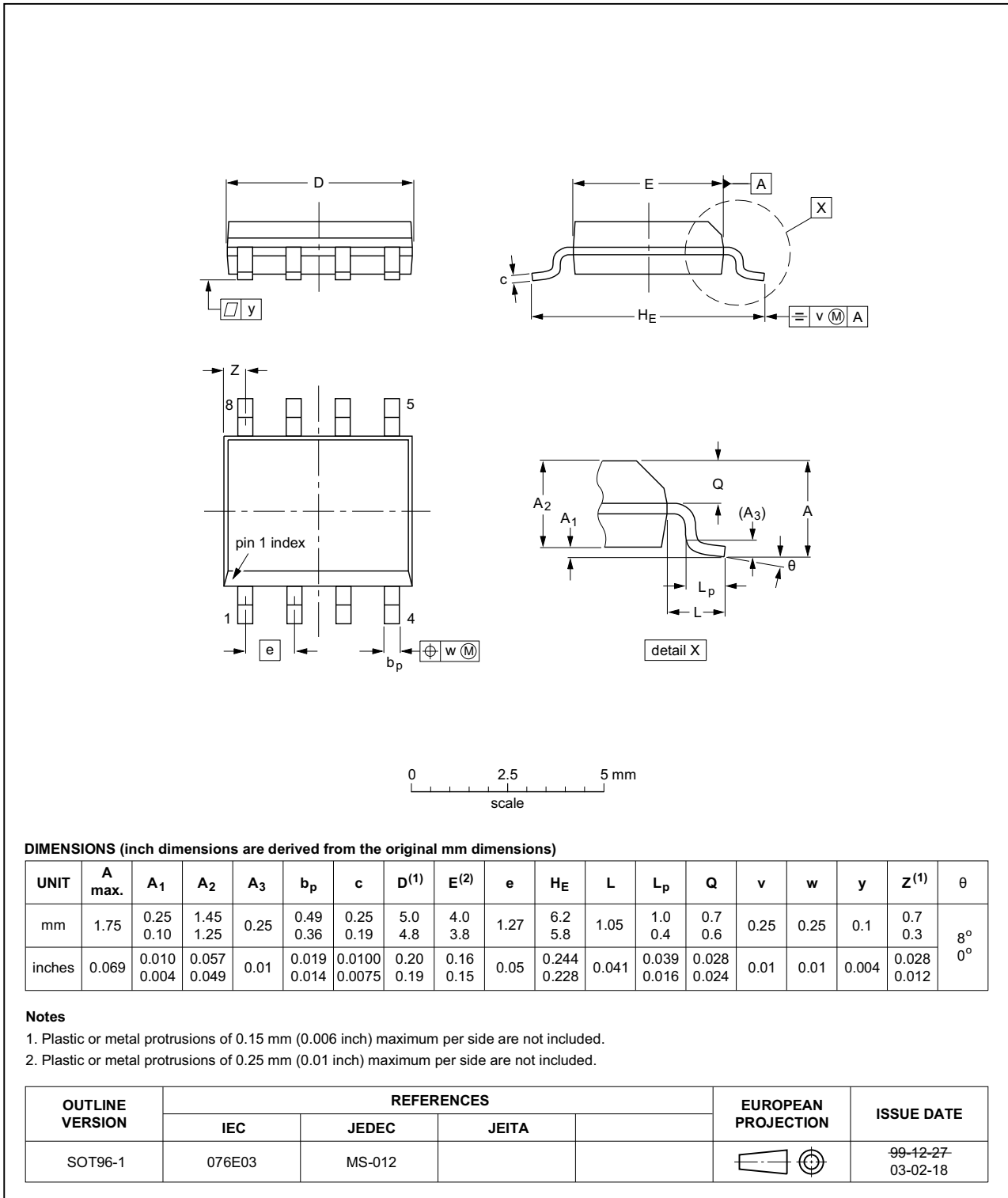

Fig 4. Package outline SOT96-1 (SO8)

## 14. Revision history

Table 7. Revision history

Document ID	Release date	Data sheet status	Change notice	Supersedes
TEA1720BT v.2	20140307	Product data sheet	-	TEA1720BT v.1
Modifications:	<ul style="list-style-type: none"><li>The data sheet status has changed from objective to product.</li></ul>			
TEA1720BT v.1	20131204	Objective data sheet	-	-

## 15. Legal information

### 15.1 Data sheet status

Document status <sup>[1][2]</sup>	Product status <sup>[3]</sup>	Definition
Objective [short] data sheet	Development	This document contains data from the objective specification for product development.
Preliminary [short] data sheet	Qualification	This document contains data from the preliminary specification.
Product [short] data sheet	Production	This document contains the product specification.

[1] Please consult the most recently issued document before initiating or completing a design.

[2] The term 'short data sheet' is explained in section "Definitions".

[3] The product status of device(s) described in this document may have changed since this document was published and may differ in case of multiple devices. The latest product status information is available on the Internet at URL <http://www.nxp.com>.

### 15.2 Definitions

**Draft** — The document is a draft version only. The content is still under internal review and subject to formal approval, which may result in modifications or additions. NXP Semiconductors does not give any representations or warranties as to the accuracy or completeness of information included herein and shall have no liability for the consequences of use of such information.

**Short data sheet** — A short data sheet is an extract from a full data sheet with the same product type number(s) and title. A short data sheet is intended for quick reference only and should not be relied upon to contain detailed and full information. For detailed and full information see the relevant full data sheet, which is available on request via the local NXP Semiconductors sales office. In case of any inconsistency or conflict with the short data sheet, the full data sheet shall prevail.

**Product specification** — The information and data provided in a Product data sheet shall define the specification of the product as agreed between NXP Semiconductors and its customer, unless NXP Semiconductors and customer have explicitly agreed otherwise in writing. In no event however, shall an agreement be valid in which the NXP Semiconductors product is deemed to offer functions and qualities beyond those described in the Product data sheet.

### 15.3 Disclaimers

**Limited warranty and liability** — Information in this document is believed to be accurate and reliable. However, NXP Semiconductors does not give any representations or warranties, expressed or implied, as to the accuracy or completeness of such information and shall have no liability for the consequences of use of such information. NXP Semiconductors takes no responsibility for the content in this document if provided by an information source outside of NXP Semiconductors.

In no event shall NXP Semiconductors be liable for any indirect, incidental, punitive, special or consequential damages (including - without limitation - lost profits, lost savings, business interruption, costs related to the removal or replacement of any products or rework charges) whether or not such damages are based on tort (including negligence), warranty, breach of contract or any other legal theory.

Notwithstanding any damages that customer might incur for any reason whatsoever, NXP Semiconductors' aggregate and cumulative liability towards customer for the products described herein shall be limited in accordance with the *Terms and conditions of commercial sale* of NXP Semiconductors.

**Right to make changes** — NXP Semiconductors reserves the right to make changes to information published in this document, including without limitation specifications and product descriptions, at any time and without notice. This document supersedes and replaces all information supplied prior to the publication hereof.

**Suitability for use** — NXP Semiconductors products are not designed, authorized or warranted to be suitable for use in life support, life-critical or safety-critical systems or equipment, nor in applications where failure or malfunction of an NXP Semiconductors product can reasonably be expected to result in personal injury, death or severe property or environmental damage. NXP Semiconductors and its suppliers accept no liability for inclusion and/or use of NXP Semiconductors products in such equipment or applications and therefore such inclusion and/or use is at the customer's own risk.

**Applications** — Applications that are described herein for any of these products are for illustrative purposes only. NXP Semiconductors makes no representation or warranty that such applications will be suitable for the specified use without further testing or modification.

Customers are responsible for the design and operation of their applications and products using NXP Semiconductors products, and NXP Semiconductors accepts no liability for any assistance with applications or customer product design. It is customer's sole responsibility to determine whether the NXP Semiconductors product is suitable and fit for the customer's applications and products planned, as well as for the planned application and use of customer's third party customer(s). Customers should provide appropriate design and operating safeguards to minimize the risks associated with their applications and products.

NXP Semiconductors does not accept any liability related to any default, damage, costs or problem which is based on any weakness or default in the customer's applications or products, or the application or use by customer's third party customer(s). Customer is responsible for doing all necessary testing for the customer's applications and products using NXP Semiconductors products in order to avoid a default of the applications and the products or of the application or use by customer's third party customer(s). NXP does not accept any liability in this respect.

**Limiting values** — Stress above one or more limiting values (as defined in the Absolute Maximum Ratings System of IEC 60134) will cause permanent damage to the device. Limiting values are stress ratings only and (proper) operation of the device at these or any other conditions above those given in the Recommended operating conditions section (if present) or the Characteristics sections of this document is not warranted. Constant or repeated exposure to limiting values will permanently and irreversibly affect the quality and reliability of the device.

**Terms and conditions of commercial sale** — NXP Semiconductors products are sold subject to the general terms and conditions of commercial sale, as published at <http://www.nxp.com/profile/terms>, unless otherwise agreed in a valid written individual agreement. In case an individual agreement is concluded only the terms and conditions of the respective agreement shall apply. NXP Semiconductors hereby expressly objects to applying the customer's general terms and conditions with regard to the purchase of NXP Semiconductors products by customer.

**No offer to sell or license** — Nothing in this document may be interpreted or construed as an offer to sell products that is open for acceptance or the grant, conveyance or implication of any license under any copyrights, patents or other industrial or intellectual property rights.

**Export control** — This document as well as the item(s) described herein may be subject to export control regulations. Export might require a prior authorization from competent authorities.

**Quick reference data** — The Quick reference data is an extract of the product data given in the Limiting values and Characteristics sections of this document, and as such is not complete, exhaustive or legally binding.

**Non-automotive qualified products** — Unless this data sheet expressly states that this specific NXP Semiconductors product is automotive qualified, the product is not suitable for automotive use. It is neither qualified nor tested in accordance with automotive testing or application requirements. NXP Semiconductors accepts no liability for inclusion and/or use of non-automotive qualified products in automotive equipment or applications.

In the event that customer uses the product for design-in and use in automotive applications to automotive specifications and standards, customer (a) shall use the product without NXP Semiconductors' warranty of the product for such automotive applications, use and specifications, and (b)

whenever customer uses the product for automotive applications beyond NXP Semiconductors' specifications such use shall be solely at customer's own risk, and (c) customer fully indemnifies NXP Semiconductors for any liability, damages or failed product claims resulting from customer design and use of the product for automotive applications beyond NXP Semiconductors' standard warranty and NXP Semiconductors' product specifications.

**Translations** — A non-English (translated) version of a document is for reference only. The English version shall prevail in case of any discrepancy between the translated and English versions.

## 15.4 Trademarks

Notice: All referenced brands, product names, service names and trademarks are the property of their respective owners.

**GreenChip** — is a trademark of NXP Semiconductors N.V.

## 16. Contact information

For more information, please visit: <http://www.nxp.com>

For sales office addresses, please send an email to: [salesaddresses@nxp.com](mailto:salesaddresses@nxp.com)

17. Contents

1 General description . . . . . 1

2 Features and benefits . . . . . 1

2.1 Power features . . . . . 1

2.2 Green features . . . . . 2

2.3 Protection features . . . . . 2

3 Applications . . . . . 2

4 Quick reference data . . . . . 2

5 Ordering information . . . . . 3

6 Block diagram . . . . . 3

7 Pinning information . . . . . 3

7.1 Pinning . . . . . 3

7.2 Pin description . . . . . 4

8 Functional description . . . . . 4

8.1 Start-up . . . . . 4

8.2 Primary sensing . . . . . 4

8.3 Operating modes . . . . . 4

8.3.1 Constant Voltage with Burst mode (CVB) . . . . . 4

8.3.2 Constant Voltage mode (CV) . . . . . 5

8.3.3 Constant Current mode (CC) . . . . . 5

8.4 Jitter . . . . . 5

8.5 Fast transient response . . . . . 5

8.6 Short pin SENSE protection . . . . . 6

8.7 Hiccup mode protection . . . . . 6

8.8 OverTemperature Protection (OTP) . . . . . 6

9 Limiting values . . . . . 6

10 Thermal characteristics . . . . . 7

11 Characteristics . . . . . 7

12 Application information . . . . . 9

13 Package outline . . . . . 10

14 Revision history . . . . . 11

15 Legal information . . . . . 12

15.1 Data sheet status . . . . . 12

15.2 Definitions . . . . . 12

15.3 Disclaimers . . . . . 12

15.4 Trademarks . . . . . 13

16 Contact information . . . . . 13

17 Contents . . . . . 14

Please be aware that important notices concerning this document and the product(s) described herein, have been included in section 'Legal information'.

© NXP Semiconductors N.V. 2014. All rights reserved.

For more information, please visit: <http://www.nxp.com>  
 For sales office addresses, please send an email to: [salesaddresses@nxp.com](mailto:salesaddresses@nxp.com)

Date of release: 7 March 2014  
 Document identifier: TEA1720BT

## Looking for pricing, stock, or lifecycle information?

Click below to explore more details on WIN SOURCE:

- ⊖ [View TEA1720BT/1J on WIN SOURCE](#)
- ⊖ [NXP / Nexperia Information](#)

## Optimize Your Supply Chain with WIN SOURCE Solutions

- ✓ Global Sourcing Solution
- ✓ Obsolete Management
- ✓ Cost Control Management
- ✓ Shortage Management
- ✓ Alternative Solution
- ✓ Excess Inventory Management