



THE DATASHEET OF TL431BILP



DESCRIPTION

The TL431/TL431A/TL431B series precision adjustable three terminal shunt voltage regulators are pin-to-pin compatible with the industry standard TL431. The output voltage of this reference is programmable by using two external resistors from 2.5V to 36V. These devices offer low output impedance for improved load regulation. The typical output impedance of these devices is 200mΩ. These devices find application in the feedback path of switching power supplies, OVP crowbar circuits, reference for A/D, D/A, and as zener diodes with improved turn-on characteristics.

IMPORTANT: For the most current data, consult MICROSEMI's website: <http://www.microsemi.com>

KEY FEATURES

- INITIAL VOLTAGE REFERENCE ACCURACY OF 0.4% (TL431B)
- SINK CURRENT CAPABILITY 1mA to 100mA
- TYPICAL OUTPUT DYNAMIC IMPEDANCE LESS THAN 200mΩ; TYPICAL OUTPUT IMPEDANCE OF THE TL431B LESS THAN 100mΩ
- ADJUSTABLE OUTPUT VOLTAGE FROM 2.5V TO 36V
- AVAILABLE IN SURFACE-MOUNT PACKAGES
- LOW OUTPUT NOISE
- TYPICAL EQUIVALENT FULL RANGE TEMPERATURE COEFFICIENT OF 30ppm/°C
- DIRECT PIN-TO-PIN REPLACEMENT FOR INDUSTRY STANDARD TL431 AND TL1431

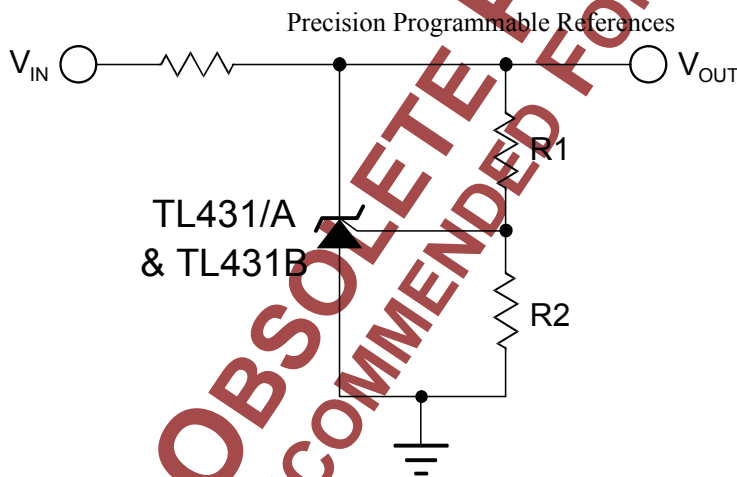
PRODUCT HIGHLIGHT

$$V_O = \left(1 + \frac{R1}{R2}\right) \cdot V_{REF}$$

PACKAGE ORDER INFO

T _A (°C)	Initial Tolerance	DM	LP	PK
		Plastic SOIC 8-Pin RoHS Compliant / Pb-free Transition DC: 0440	Plastic TO-92 3-Pin RoHS Compliant / Pb-free Transition DC: 0509	Plastic TO-89 3 - Pin RoHS Compliant / Pb-free Transition DC: 0518
0 to 70	2%	TL431CDM	TL431CLP	TL431CPK
	1%	TL431ACDM	TL431ACL	TL431ACPK
	0.4%	TL431BCDM	TL431BCLP	TL431BCPK
-40 to 85	2%	TL431IDM	TL431ILP	TL431IPK
	1%	TL431AIDM	TL431AILP	TL431AIPK
	0.4%	TL431BIDM	TL431BILP	TL461BIPK

Note: All surface mount packages are available in Tape & Reel. Append the letters "TR" to the part number. (i.e. LTL431AIDM-TR). The TO-92 (LP) package is available in ammo-pack.

ABSOLUTE MAXIMUM RATINGS

Cathode to Anode Voltage (VKA)(Note 2)	-0.3 to 37V
Reference Input Current (IREF).....	-50 μ A to 10mA
Continuous Cathode Current (IK).....	-100mA to 150mA
Operating Junction Temperature.....	150 $^{\circ}$ C
Storage Temperature Range.....	-65 $^{\circ}$ C to 150 $^{\circ}$ C
Package Peak Temp. for Solder Reflow (40 seconds maximum exposure) ...	260 $^{\circ}$ C (+0 -5)

Note: Exceeding these ratings could cause damage to the device. All voltages are with respect to Ground. Currents are positive into, negative out of specified terminal.

Note 2. Voltage values are with respect to the anode terminal unless otherwise noted.

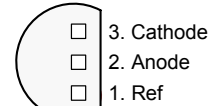
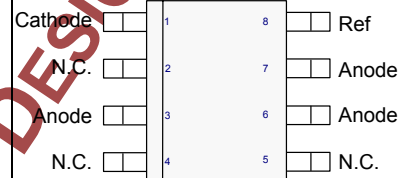
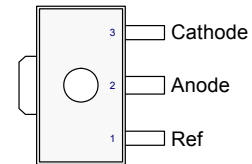
PACKAGE PIN OUT

LP PACKAGE
(Top View)

DM PACKAGE
(Top View)

PK PACKAGE
(Top View)

RoHS / Pb-free 100% Matte Tin Lead Finish

THERMAL DATA
DM Plastic SOIC 8-Pin

THERMAL RESISTANCE-JUNCTION TO AMBIENT, θ_{JA}	165 $^{\circ}$ C/W
---	--------------------

PK Plastic TO-89 3-Pin

THERMAL RESISTANCE-JUNCTION TO AMBIENT, θ_{JA}	71 $^{\circ}$ C/W
---	-------------------

LP Plastic TO-92 3-Pin

THERMAL RESISTANCE-JUNCTION TO AMBIENT, θ_{JA}	156 $^{\circ}$ C/W
---	--------------------

Junction Temperature Calculation: $T_J = T_A + (P_D \times \theta_{JA})$.

The θ_{JA} numbers are guidelines for the thermal performance of the device/pc-board system. All of the above assume no ambient airflow.

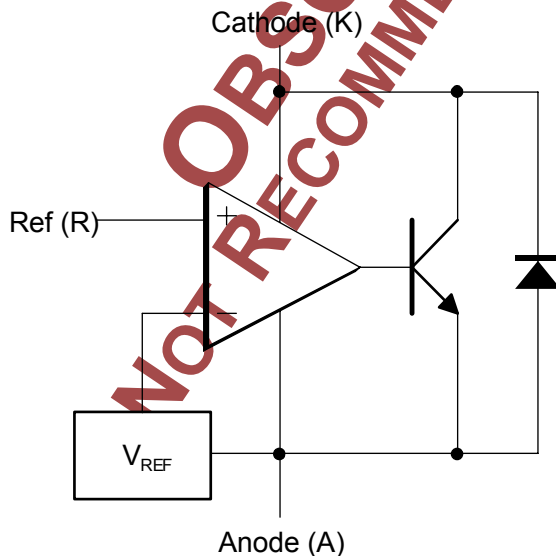
BLOCK DIAGRAM

ELECTRICAL CHARACTERISTICS

Unless otherwise specified, these specifications apply over the operating ambient temperature for the TL431C/TL431AC/TL431BC with $0^{\circ}\text{C} \leq T_A \leq 70^{\circ}\text{C}$, and TL431I/TL431AI/TL431BI with $-40^{\circ}\text{C} \leq T_A \leq 85^{\circ}\text{C}$

Parameter	Symbol	Test Conditions	TL431A/B			Units
			Min	Typ	Max	
Reference Input Voltage	TL431	$I_K = 10\text{mA}, V_{KA} = V_{REF}, T_A = 25^{\circ}\text{C}$	2440	2495	2550	mV
	TL431A	$I_K = 10\text{mA}, V_{KA} = V_{REF}, T_A = 25^{\circ}\text{C}$	2470	2495	2520	
	TL431B	$I_K = 10\text{mA}, V_{KA} = V_{REF}, T_A = 25^{\circ}\text{C}$	2490	2500	2510	
Reference Drift	TL431C	$I_K = 10\text{mA}, V_{KA} = V_{REF}$		4	17	mV
	TL431I	$I_K = 10\text{mA}, V_{KA} = V_{REF}$		5	30	
	TL431AC	$I_K = 10\text{mA}, V_{KA} = V_{REF}$		4	17	
	TL431AI	$I_K = 10\text{mA}, V_{KA} = V_{REF}$		5	30	
	TL431BC	$I_K = 10\text{mA}, V_{KA} = V_{REF}$		4	15	
	TL431BI	$I_K = 10\text{mA}, V_{KA} = V_{REF}$		5	20	
Voltage Ratio, Ref to Cathode (Note 4)	TL431, TL431A	$I_K = 10\text{mA}, V_{KA} = 2.5\text{V to } 36\text{V}$		-1.4	-2.7	mV/V
	TL431B	$I_K = 10\text{mA}, V_{KA} = 2.5\text{V to } 36\text{V}$		-1.1	-2.0	
Reference Input Current	TL431, TL431A	$V_{KA} = V_{REF}, T_A = 25^{\circ}\text{C}$		2	4	μA
	TL431B	$V_{KA} = V_{REF}, T_A = 25^{\circ}\text{C}$		1.5	1.9	
Minimum Operating Current		$V_{KA} = V_{REF} \text{ to } 36\text{V}$		0.4	1	mA
Off-State Cathode Current	TL431	$V_{KA} = V_{REF} \text{ to } 36\text{V}, T_A = 25^{\circ}\text{C}$		0.1	1	μA
	TL431A	$V_{KA} = V_{REF} \text{ to } 36\text{V}, T_A = 25^{\circ}\text{C}$		0.1	1	
	TL431B	$V_{KA} = V_{REF} \text{ to } 36\text{V}, T_A = \text{Operating Range}$			2	
		$V_{KA} = 36\text{V}, V_{REF} = 0\text{V}, T_A = 25^{\circ}\text{C}$		0.18	0.5	
Dynamic Impedance	TL431	$V_{KA} = V_{REF}, I_K = 1\text{mA to } 100\text{mA}, f < 1\text{kHz}, T_A = 25^{\circ}\text{C}$		0.2	0.5	Ω
	TL431B	$V_{KA} = V_{REF}, I_K = 1\text{mA to } 100\text{mA}, f < 1\text{kHz}, T_A = 25^{\circ}\text{C}$		0.1	0.2	

Note 3: These parameters are guaranteed by design.

Note 4: $\frac{\Delta V_{REF}}{\Delta V_{KA}}$ Ratio of change in reference input voltage to the change in cathode voltage.

OBSOLETE PRODUCT NOT RECOMMENDED FOR NEW DESIGNS

GRAPH / CURVE INDEX**Characteristic Curves**

- Figure #
1. Reference Input Voltage vs. Free-Air Temperature
 2. Reference Input Current vs. Free-Air Temperature
 3. Cathode Current vs. Cathode Voltage
 4. Cathode Current vs. Cathode Voltage
 5. Off-State Cathode Current vs. Free-Air Temperature
 6. Ratio of Delta Reference Voltage to Delta Cathode Voltage vs. Free-Air Temperature
 7. Equivalent Input Noise Voltage vs. Frequency

FIGURE INDEX**Parameter Measurement Information**

- Figure #
8. Test Circuit For $V_{KA} = V_{REF}$
 9. Test Circuit For $V_{KA} > V_{REF}$
 10. Test Circuit for I_{OFF}

Typical Characteristics

- Figure #
11. Equivalent Input Noise Voltage Over a 10-Second Period
 12. Small-Signal Voltage Amplification vs. Frequency
 13. Reference Impedance vs. Frequency
 14. Pulse Response
 15. Stability Boundary Conditions

Application Information

- Figure #
16. Shunt Regulator
 17. Single-Supply Comparator with Temperature-Compensated Threshold
 18. High Current Shunt Regulator
 19. Crowbar Circuit
 20. Voltage Monitor
 21. Precision Constant-Current Sink

OBSOLETE PRODUCT DESIGN
NOT RECOMMENDED FOR NEW DESIGNS

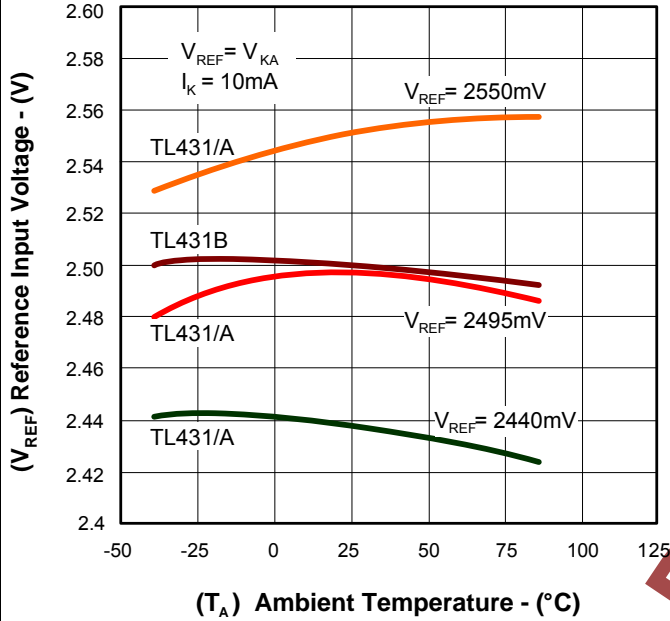
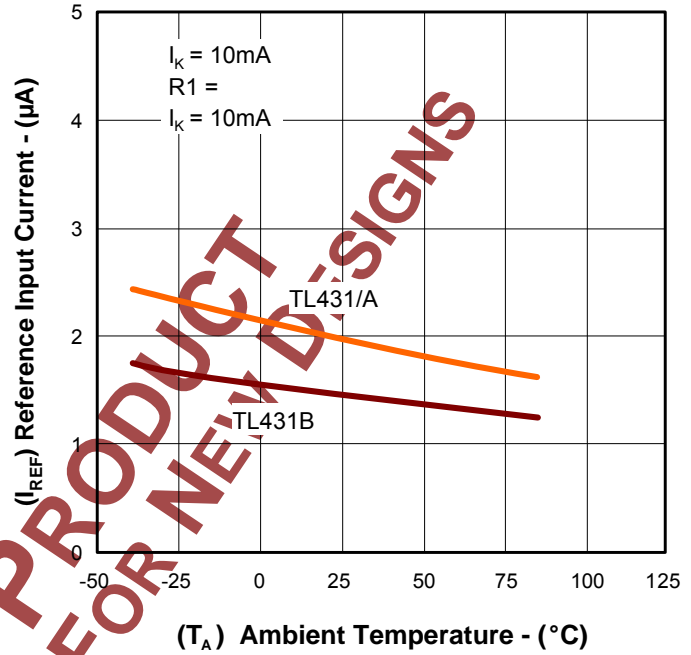
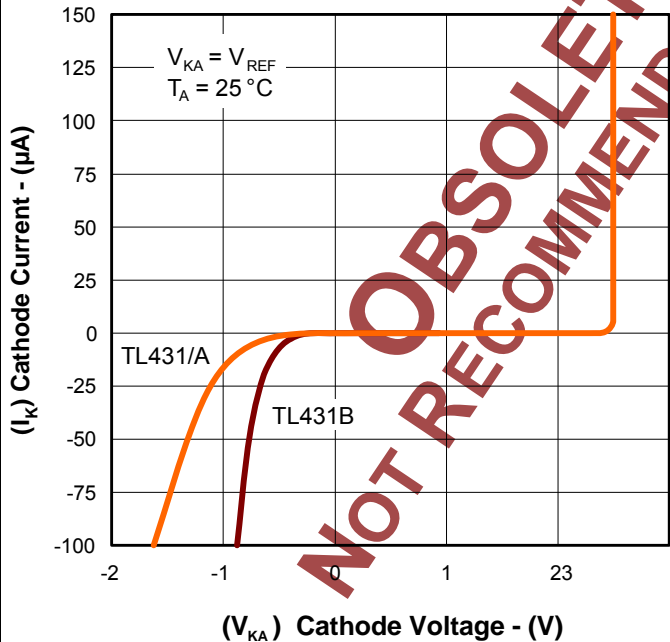
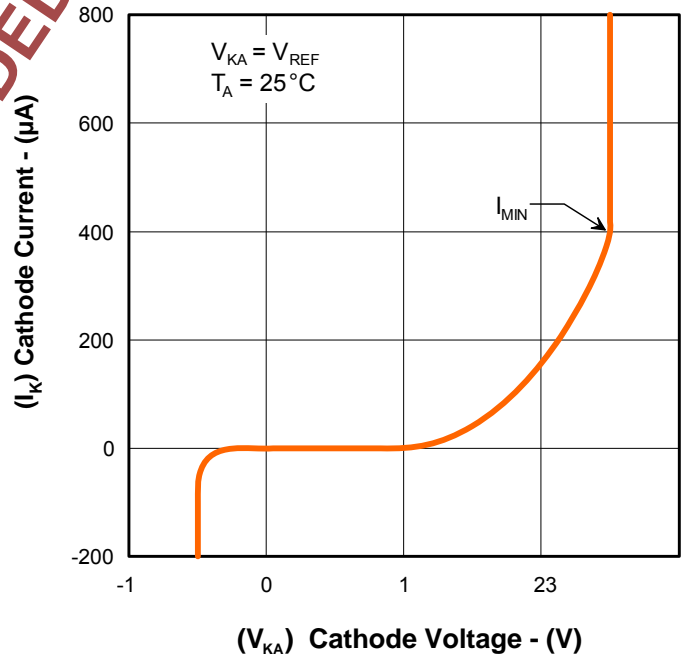
CHARACTERISTIC CURVES

Figure 1 – Reference Voltage vs. Free-Air Temperature

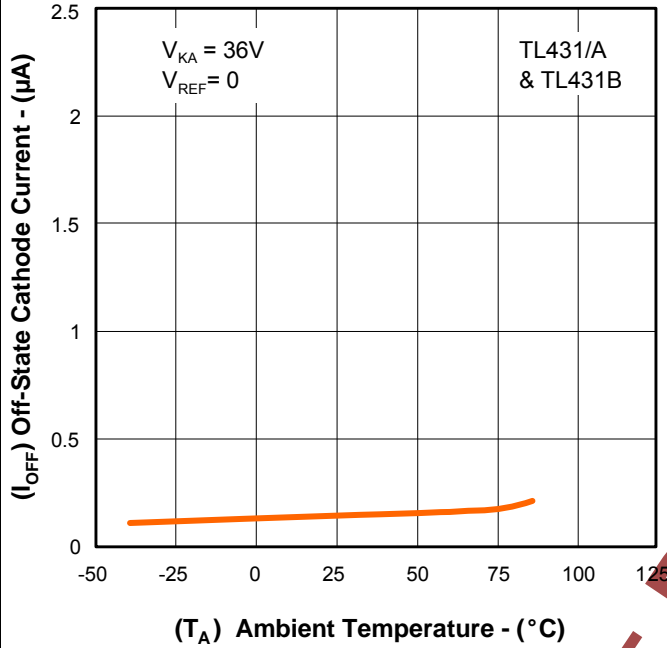
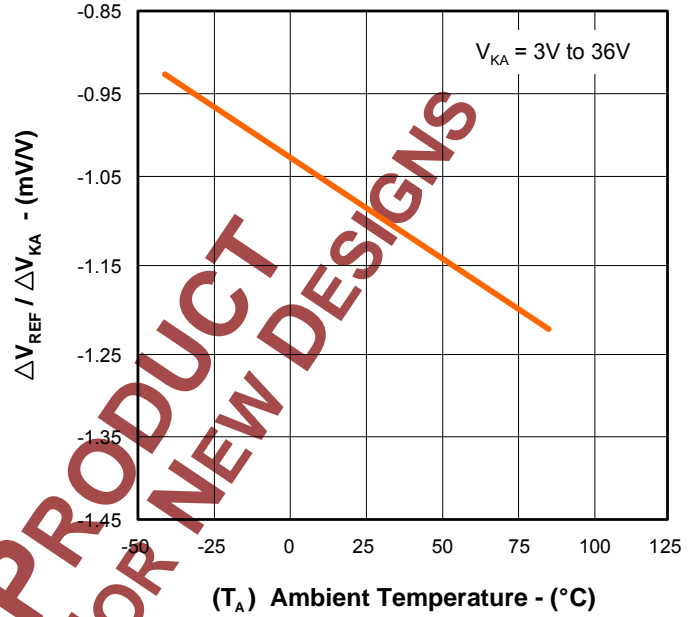
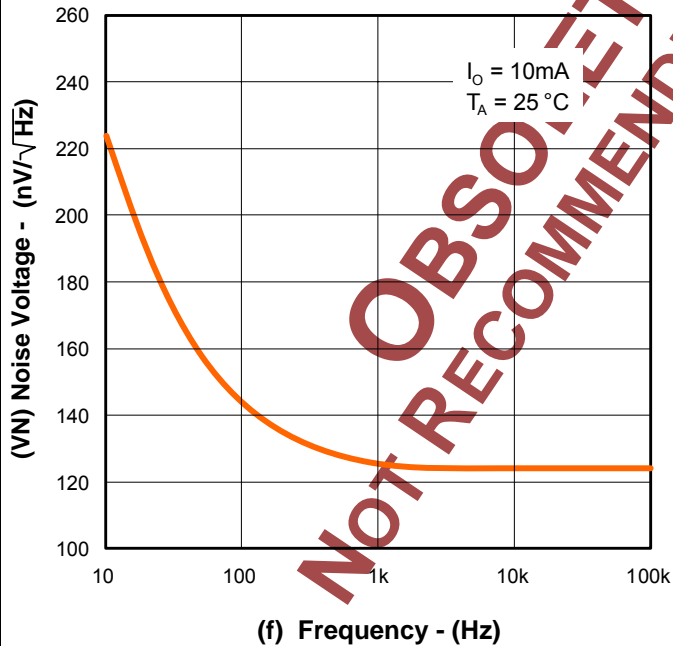
Figure 2 – Reference Current vs. Free-Air Temperature

Figure 3 – Cathode Current vs. Cathode Voltage

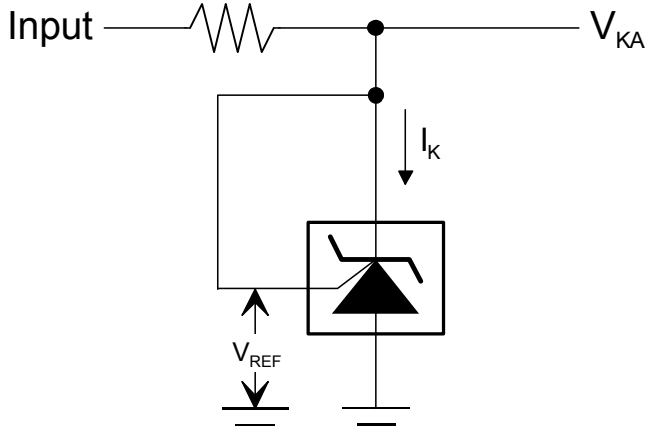
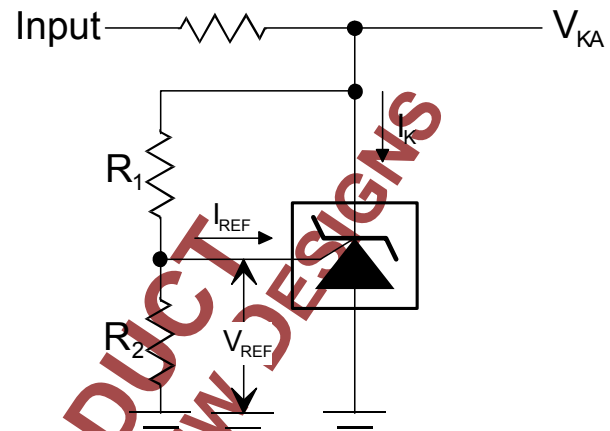
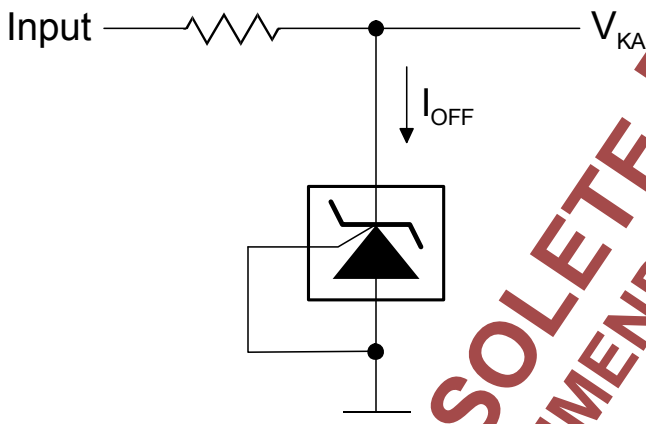
Figure 4 – Cathode Current vs. Cathode Voltage

NOT RECOMMENDED FOR NEW DESIGNS

CHARACTERISTIC CURVES

Figure 5 – Off-State Cathode Current vs Free-Air Temperature

Figure 6 – Ratio of Delta Reference Voltage to Delta Cathode Voltage vs. Free-Air Temperature

Figure 7 – Equivalent Input Noise Voltage vs. Frequency

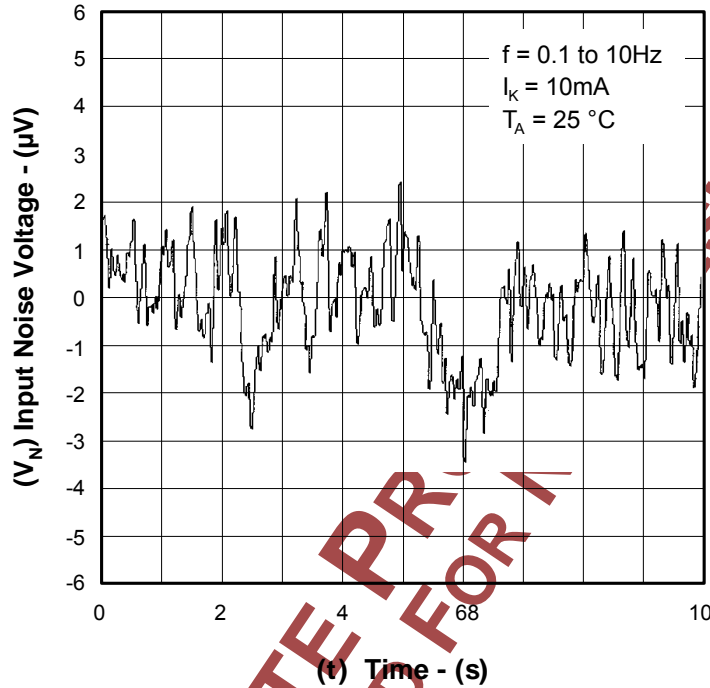
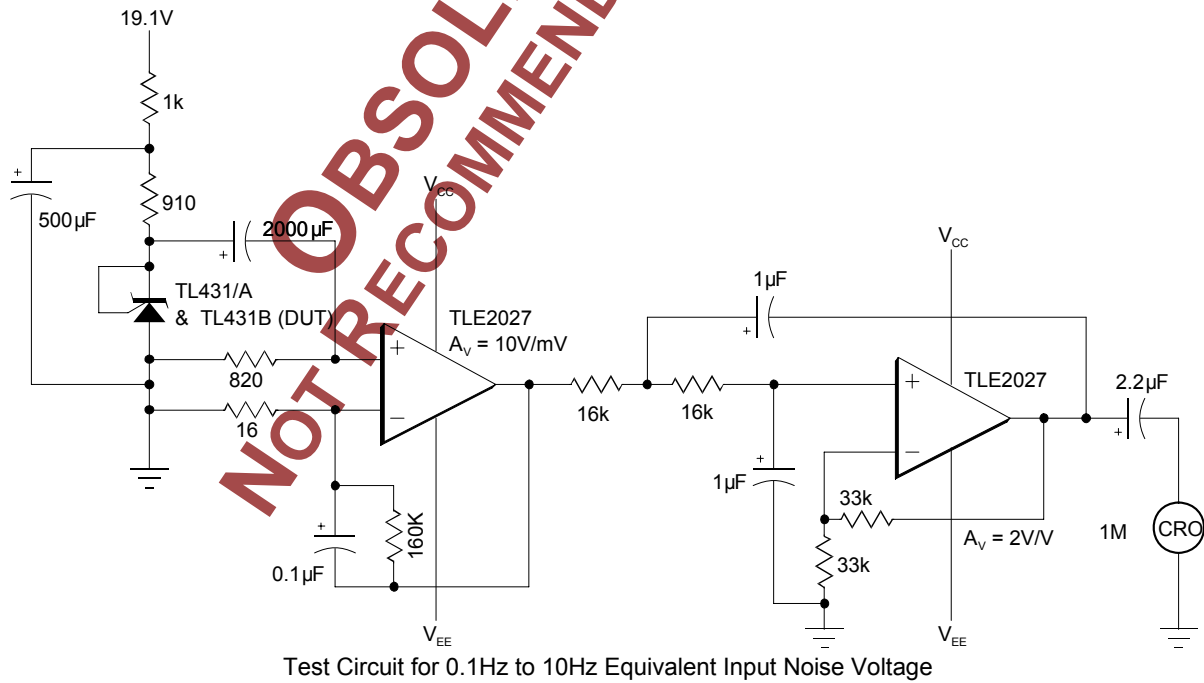
OBSOLETE PRODUCT NOT RECOMMENDED FOR NEW DESIGNS

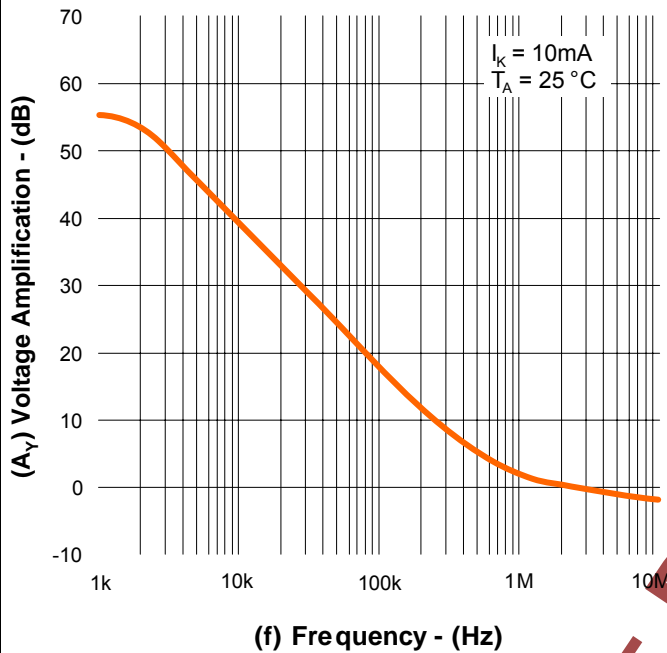
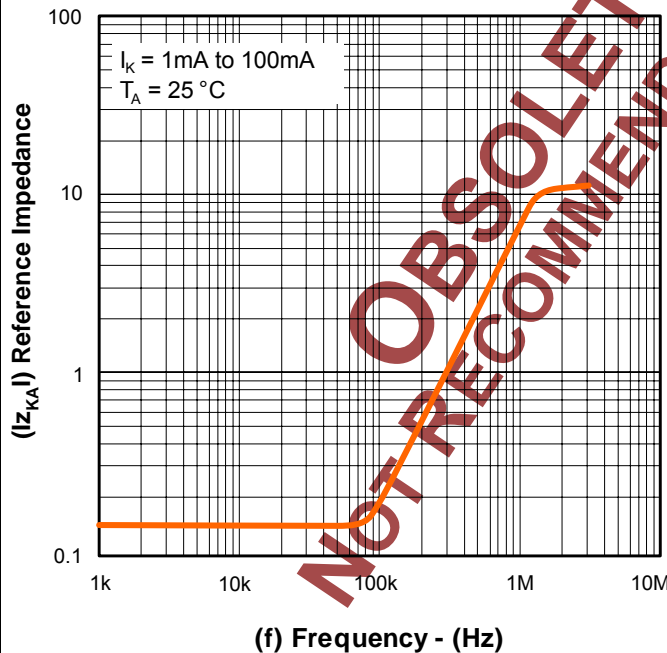
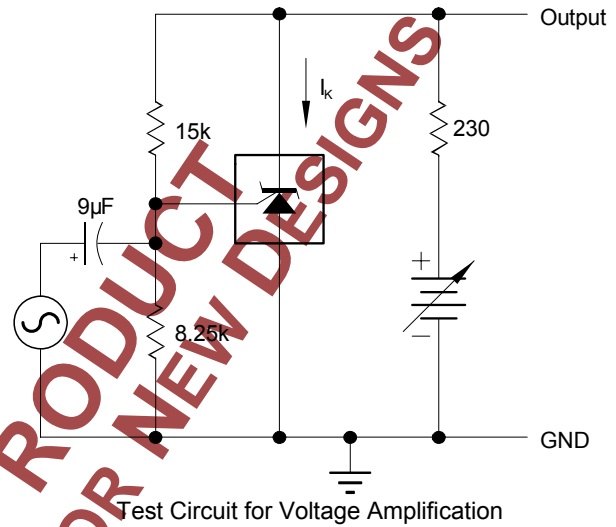
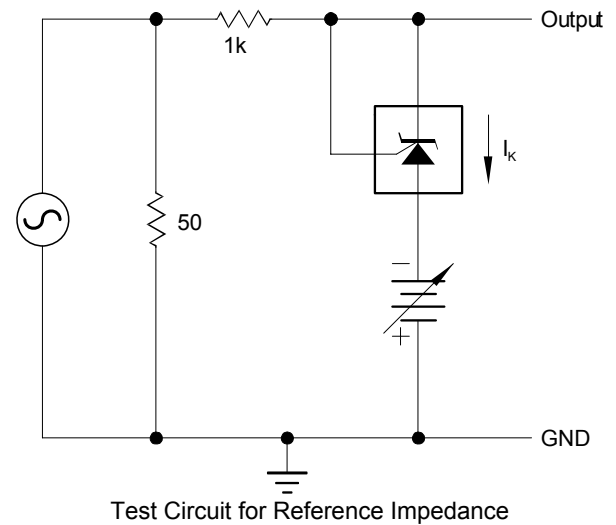
PARAMETER MEASUREMENT INFORMATION

Figure 8 – Test Circuit for $V_{KA} = V_{REF}$

Figure 9 – Test Circuit for $V_{KA} > V_{REF}$

Figure 10 – Test Circuit for I_{OFF}

OBSOLETE PRODUCT NOT RECOMMENDED FOR NEW DESIGNS

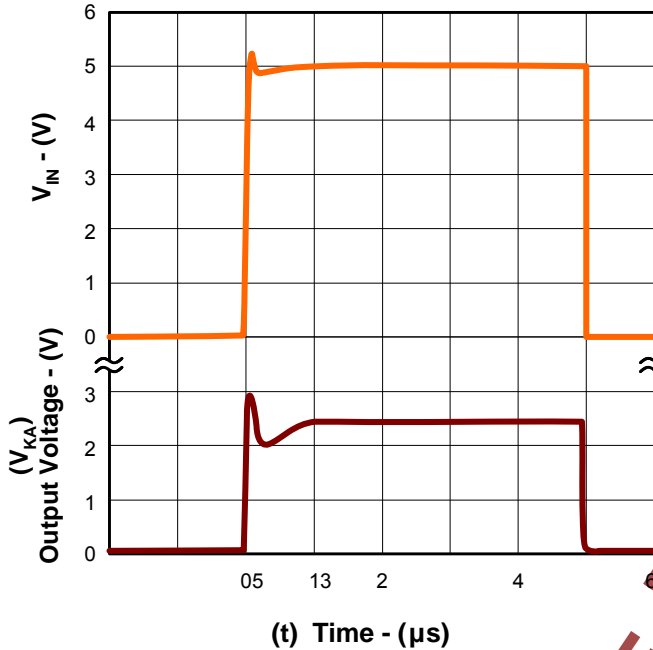
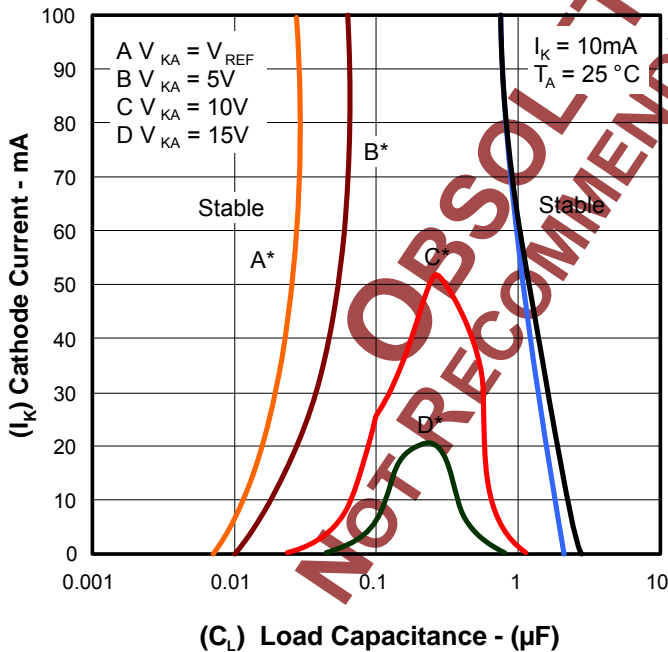
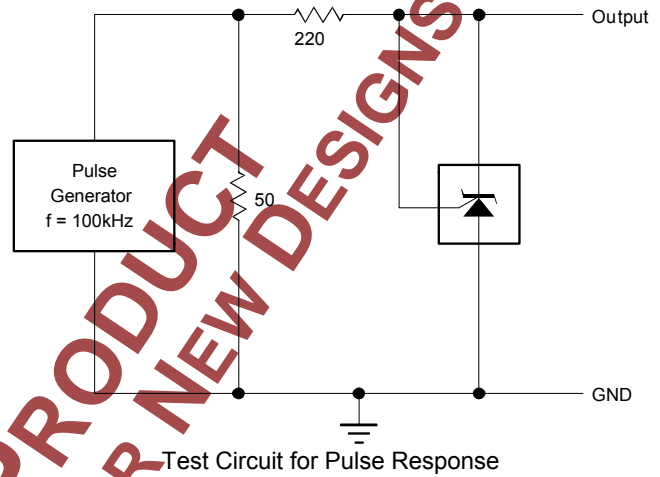
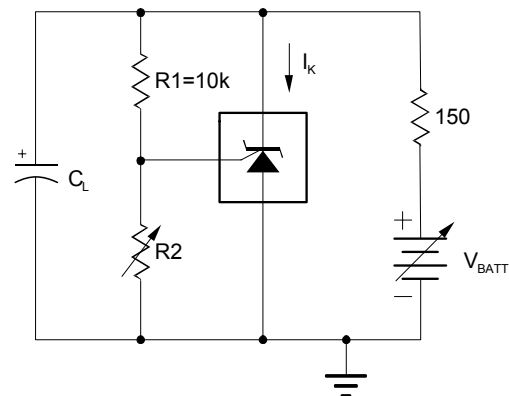
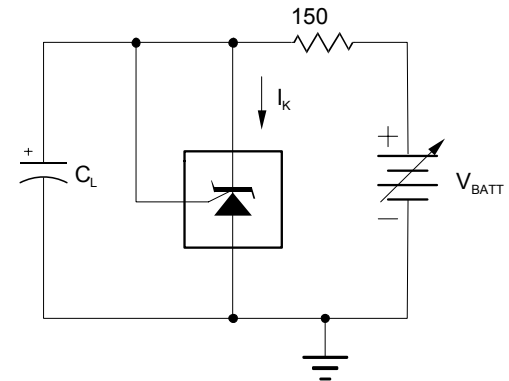
TYPICAL CHARACTERISTICS

Figure 11 – Equivalent Input Noise Voltage over a 10 – Second Period

TYPICAL CHARACTERISTICS

Figure 12 – Reference Impedance vs. Frequency

Figure 13 – Reference Impedance vs. Frequency

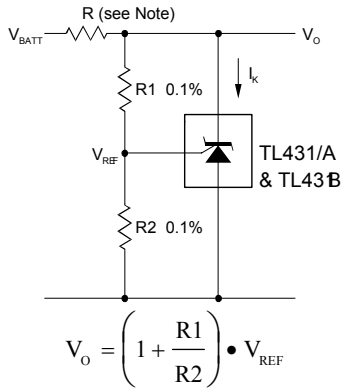
OBSOLETE PRODUCT NOT RECOMMENDED FOR NEW DESIGNS

TYPICAL CHARACTERISTICS

Figure 14 – Pulse Response

Figure 15 – Stability Boundary Conditions

Test Circuit for Curve A

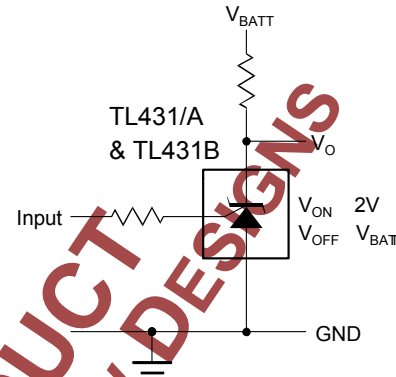
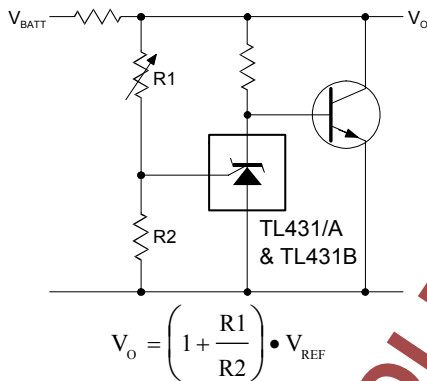
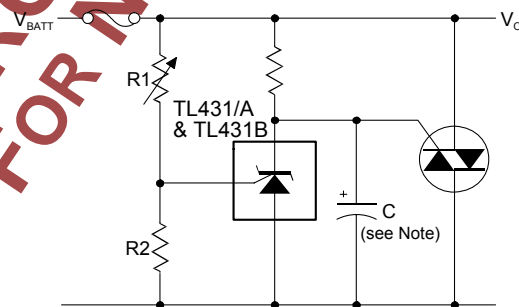
Test Circuit for Curve B, C, D

*The areas under the curves represent conditions that may cause the device to oscillate. For curves B, C, and D, R2 and V+ were adjusted to establish the initial V_{KA} and I_K conditions with $C_L = 0$. V_{BATT} and C_L were then adjusted to determine the ranges of stability.

APPLICATION INFORMATION

Figure 16 – Shunt Regulator

Note: R should provide > 1mA cathode current to the TL431/A & TL431 at minimum V_{BATT}

Figure 17 – Single-Supply Comparator with Temperature-Compensated Threshold

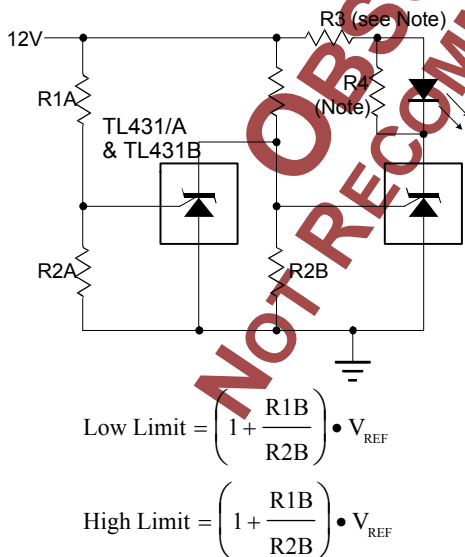
Figure 18 – High Current Shunt Regulator

Figure 19 – Crowbar Circuit

Note: Refer to the stability boundary conditions in Figure 15 to determine allowable values for C.



LED on when Low Limit < V_{BATT} < High Limit

Figure 20 – Voltage Monitor

Note: R3 and R4 are selected to provide the desired LED intensity and > 1mA cathode current to the TL431/A & TL431B at the available $V+$

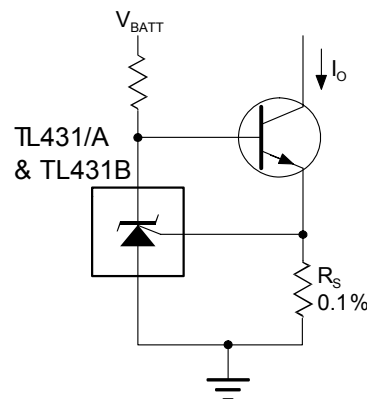
Figure 21 – Precision Contact – Current Sink

Looking for pricing, stock, or lifecycle information?

Click below to explore more details on WIN SOURCE:

- ⊖ [View TL431BILP on WIN SOURCE](#)
- ⊖ [Microsemi Corporation Information](#)

Optimize Your Supply Chain with WIN SOURCE Solutions

- ✓ Global Sourcing Solution
- ✓ Obsolete Management
- ✓ Cost Control Management
- ✓ Shortage Management
- ✓ Alternative Solution
- ✓ Excess Inventory Management