



**THE DATASHEET OF
UC3903Q**



Quad Supply and Line Monitor

FEATURES

- Inputs for Monitoring up to Four Separate Supply Voltage Levels
- Internal Inverter for Sensing a Negative Supply Voltage
- Line/Switch Sense Input for Early Power Source Failure Warning
- Programmable Under- and Over-Voltage Fault Thresholds with Proportional Hysteresis
- A Precision 2.5-V Reference
- General Purpose Op-Amp for Auxiliary Use
- Three High Current, >30 mA, Open-Collector Outputs Indicate Over-Voltage, Under-Voltage and Power OK Conditions
- 8-V to 40-V Supply Operation with 7-mA Stand-By Current

DESCRIPTION

The UC1903 family of quad supply and line monitor integrated circuits will respond to under- and over-voltage conditions on up to four continuously monitored voltage levels. An internal op-amp inverter allows at least one of these levels to be negative. A separate line/switcher sense input is available to provide early warning of line or other power source failures.

The fault window adjustment circuit on these devices provides easy programming of under- and over-voltage thresholds. The thresholds, centered around a precision 2.5-V reference, have an input hysteresis that scales with the window width for precise, glitch-free operation. A reference output pin allows the sense input fault windows to be scaled independently using simple resistive dividers.

The three open collector outputs on these devices sink in excess of 30 mA of load current when active. The under- and over-voltage outputs respond after separate, user defined, delays to respective fault conditions. The third output is active during any fault condition including under- and over-voltage, line/switcher faults, and input supply under-voltage. The off state of this output indicates a "power OK" situation.

BLOCK DIAGRAM

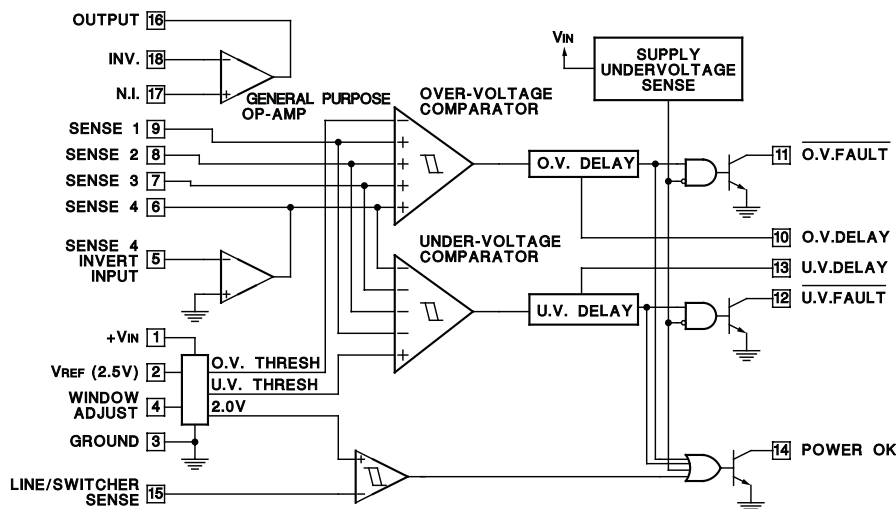

Note: Pin numbers refer to J, N and DW packages.



Please be aware that an important notice concerning availability, standard warranty, and use in critical applications of Texas Instruments semiconductor products and disclaimers thereto appears at the end of this data sheet.

DESCRIPTION (CONT.)

An additional, uncommitted, general purpose op-amp is also included. This op-amp, capable of sourcing 20 mA of output current, can be used for a number of auxiliary functions including the sensing and amplification of a feedback error signal when the 2.5-V output is used as a system reference.

These parts operate over an 8-V to 40-V input supply range and require a typical stand-by current of only 7 mA.

CONNECTION DIAGRAMS

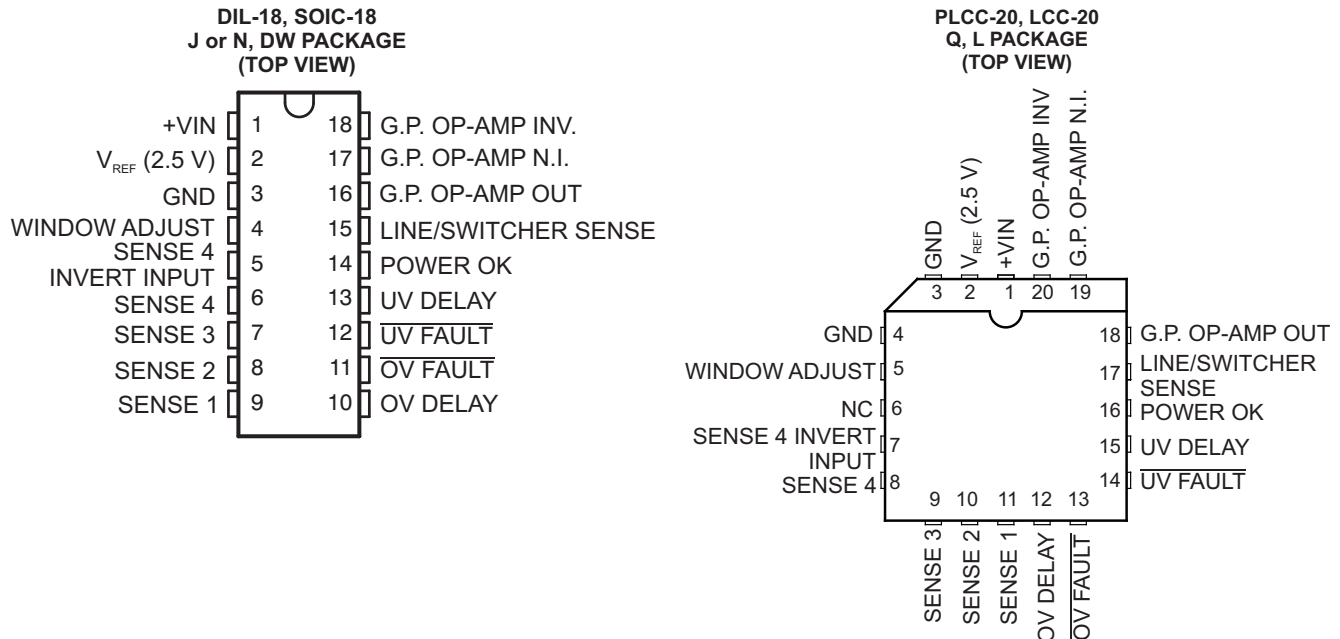

ABSOLUTE MAXIMUM RATINGS⁽¹⁾

over operating free-air temperature range (unless otherwise noted)

	VALUE	UNIT
+VIN Supply Voltage	+40	V
Open Collector Output Voltages.	+40	V
Open Collector Output Currents.	50	mA
Sense 1-4 Input Voltages	-0.3 to +20	V
Line/Switcher Sense Input Voltage	-0.3 to +40	V
Op-Amp and Inverter Input Voltages	-0.3 to +40	V
Op-Amp and Inverter Output Currents .	-40	mA
Window Adjust Voltage.	0.0 to +10	V
Delay Pin Voltages	0.0 to +5	V
Reference Output Current	-40	mA
Power Dissipation at T _A = 25°C ⁽¹⁾	1000	mW
Power Dissipation at T _C = 25°C ⁽¹⁾	2000	mW
Operating Junction Temperature	-55 to +150	°C
Storage Temperature	-65 to +150	C
Lead Temperature (Soldering, 10 Seconds)	300	°C

(1) Voltages are referenced to ground (Pin 3). Currents are positive into, negative out of, the specified terminals. Consult Packaging Section of Databook for thermal limitations and considerations of package.

ELECTRICAL CHARACTERISTICS

Unless otherwise stated, these specifications apply for $T_A = -55^\circ\text{C}$ to $+125^\circ\text{C}$ for the UC1903; -40°C to $+85^\circ\text{C}$ for the UC2903; and 0°C to $+70^\circ\text{C}$ for the UC3903; $+V_{IN} = 15\text{V}$; Sense Inputs (Pins 6–9 and Pin 15) = 2.5V ; $V_{PIN\ 4} = 1.0\text{V}$, $T_A = T_J$.

PARAMETER	TEST CONDITIONS	UC1903 / UC2903			UC3903			UNIT
		MIN	TYP	MAX	MIN	TYP	MAX	
SUPPLY								
Input Supply Current	No Faults		7	9		7	11	mA
	UV, OV and Line Fault		10	15		10	18	mA
Supply Under Voltage Threshold (V_{SUV})	Fault Outputs Enabled	6.0	7.0	7.5	5.5	7.0	8.0	V
Minimum Supply to Enable Power OK Output			3.0	4.0		3.0	4.0	V
REFERENCE								
Output Voltage (V_{REF})	$T_J = 25^\circ\text{C}$	2.485	2.5	2.515	2.470	2.5	2.530	V
	Over Temperature			2.535			2.535	V
Load Regulation	$I_L = 0$ to 10mA		1	10		1	15	mV
Line Regulation	$+V_{IN} = 8$ to 40V		1	4		1	8	mV
Short Circuit Current	$T_J = 25^\circ\text{C}$		40			40		mA
FAULT THRESHOLDS⁽¹⁾								
OV Threshold Adj.	Offset from V_{REF} as a function of $V_{PIN\ 4}$ 4 Input = Low to High, $0.5\text{V} \leq V_{PIN\ 4} \leq 2.5\text{V}$	0.230	0.25	0.270	0.230	0.25	0.270	V/V
UV Threshold Adj.	Offset from V_{REF} as a function of $V_{PIN\ 4}$ 4 Input = High to Low, $0.5\text{V} \leq V_{PIN\ 4} \leq 2.5\text{V}$	-0.270	-0.25	-0.230	-0.270	-0.25	-0.270	V/V
OV & UV Threshold Hyst.	$0.5\text{V} \leq V_{PIN\ 4} \leq 2.5\text{V}$	10	20	30	10	20	30	mV/V
OV & UV Threshold Supply Sensitivity	$+V_{IN} = 8\text{V}$ to 40V		0.002	0.01		0.002	0.02	%/V
Adjust Pin (Pin 4) Input Bias Current	$0.5\text{V} \leq V_{PIN\ 4} \leq 2.5\text{V}$		± 1	± 10		± 1	± 12	$\mu\text{A}/\text{V}$
Line Sense Threshold	Input = High to Low	1.94	2.0	2.06	1.9	2.0	2.1	V
Line Sense Threshold Hyst.		125	175	225	100	175	250	mV
SENSE INPUTS								
Sense 1-4 Input Bias Current	Input = 2.8V ⁽²⁾		1	3		1	6	μA
	Input = 2.2V ⁽²⁾		-1	-3		-1	-6	μA
Line Sense Input Bias Current	Input = 2.3V ⁽²⁾		1	3		1	6	μA
OV AND UV FAULT DELAY								
Charging Current			60			60		μA
Threshold Voltage	Delay Pin = Low to High		1.8			1.8		V
Threshold Hysteresis	$T_J = 25^\circ\text{C}$		250			250		mV
Delay	Ratio of Threshold Voltage to Charging Current	20	30	50	20	30	50	ms/ μF

(1) Reference to pin numbers in this specification pertain to 18 pin DIL N and J packages and 18 pin SOIC DW package.

(2) These currents represent maximum input bias currents required as the sense inputs cross appropriate thresholds.

ELECTRICAL CHARACTERISTICS (continued)

Unless otherwise stated, these specifications apply for $T_A = -55^\circ\text{C}$ to $+125^\circ\text{C}$ for the UC1903; -40°C to $+85^\circ\text{C}$ for the UC2903; and 0°C to $+70^\circ\text{C}$ for the UC3903; $+V_{IN} = 15\text{V}$; Sense Inputs (Pins 6–9 and Pin 15) = 2.5V ; $V_{PIN\ 4} = 1.0\text{V}$, $T_A = T_J$.

PARAMETER	TEST CONDITIONS	UC1903 / UC2903			UC3903			UNIT
		MIN	TYP	MAX	MIN	TYP	MAX	
FAULT OUTPUTS ($\overline{\text{OV}}$, $\overline{\text{UV}}$, AND POWER OK)								
Maximum Current	$V_{OUT} = 2\text{V}$	30	70		30	70		mA
Saturation Voltage	$I_{OUT} = 12\text{mA}$		0.25	0.40		0.25	0.40	V
Leakage Current	$V_{OUT} = 40\text{V}$		3	25		3	25	μA
SENSE 4 INVERTER⁽³⁾								
Input Offset Voltage			2	8		2	10	mV
Input Bias Current			0.1	2		0.1	4	μA
Open Loop Gain		65	80		65	80		dB
PSRR	$+V_{IN} = 8\text{ to }40\text{V}$	65	100		65	100		dB
Unity Gain Frequency			1			1		MHz
Slew Rate			0.4			0.4		$\text{V}/\mu\text{s}$
Short Circuit Current	$T_J = 2^\circ\text{C}$		40			40		mA
G.P. OP-AMP⁽³⁾								
Input Offset Voltage			1	5		1	8	mV
Input Bias Voltage			0.1	2		0.1	4	μA
Input Offset Current			0.01	.5		0.01	1.0	μA
Open Loop Gain		65	120		65	120		dB
CMRR	$V_{CM} = 0\text{ to }+V_{IN} = 2.0\text{V}$	65	100		65	100		dB
PSRR	$+V_{IN} = 8\text{ to }40\text{V}$	65	100		65	100		dB
Unity Gain Frequency			1			1		MHz
Slew Rate			0.4			0.4		$\text{V}/\mu\text{s}$
Short Circuit Current	$T_J = 25^\circ\text{C}$		40			40		mA

- (3) When either the G.P. OP-Amp, or the Sense 4 Inverter, are configured for sensing a negative supply voltage, the divider resistance at the inverting input should be chosen such that the nominal divider current is $\leq 1.4\text{mA}$. With the divider current at or below this level possible latching of the circuit is avoided. Proper operation for currents at or below 1.4mA is 100% tested in production.

Block Diagram

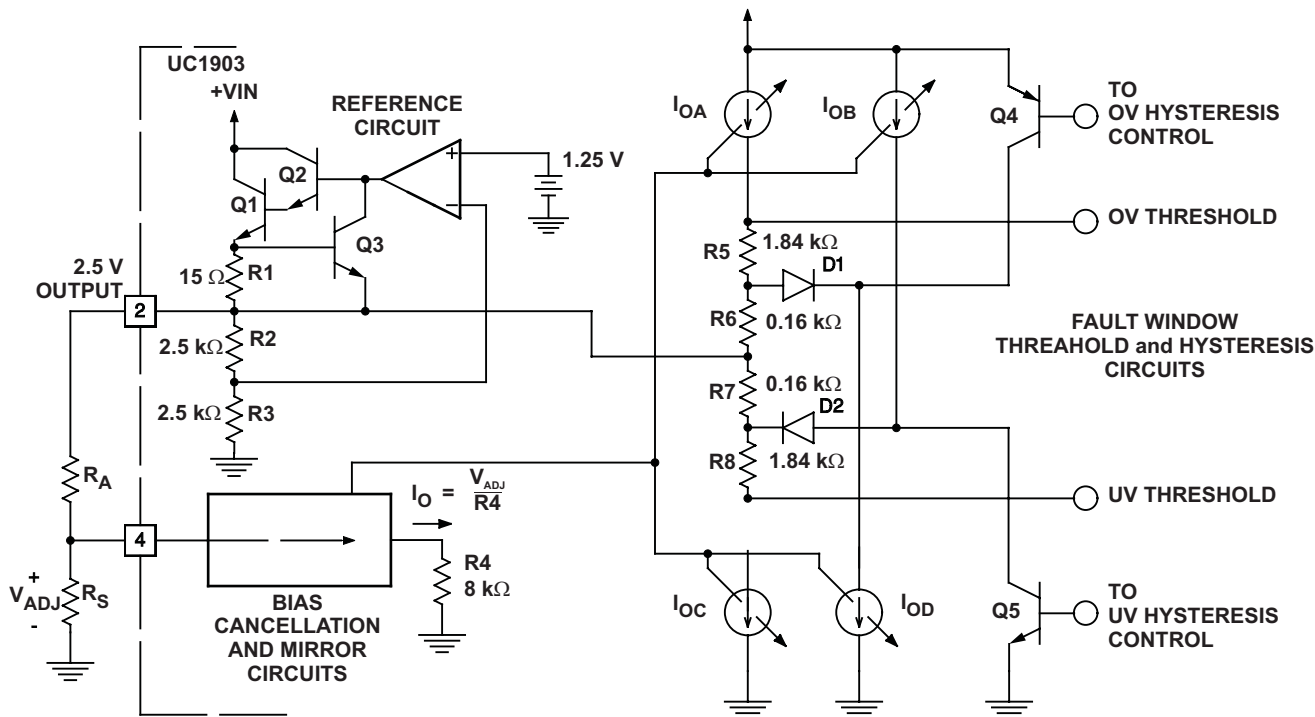

A. The UC1903 fault window circuitry generates OV and UV thresholds centered around the 2.5-V reference. Window magnitude and threshold hysteresis are proportional to the window adjust input voltage at Pin 4.

Figure 1. Operation and Application Information

Typical Characteristics

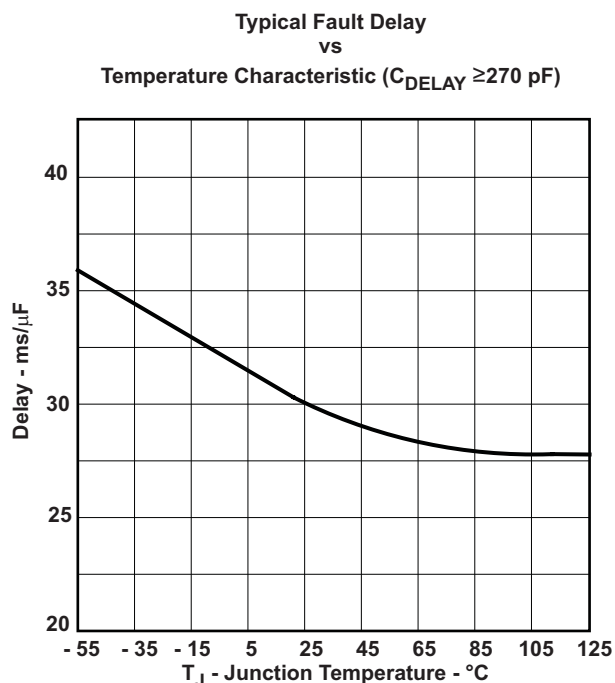
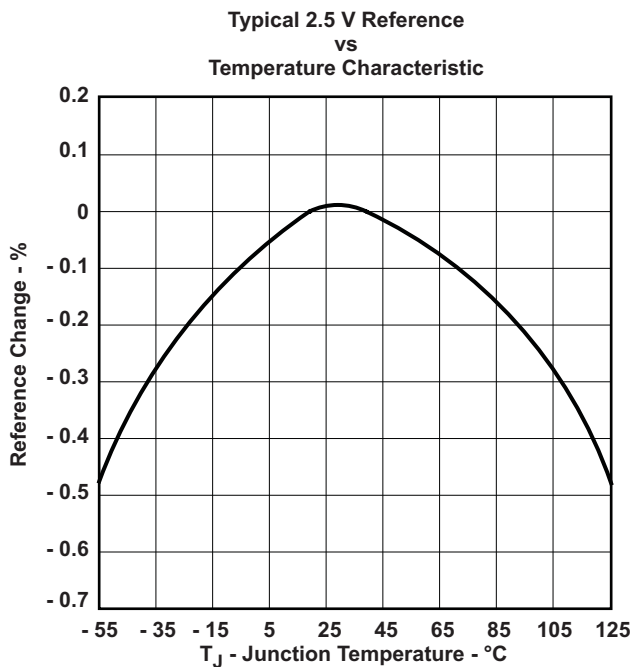

OPERATION AND APPLICATION INFORMATION

Setting a Fault Window

The fault thresholds on the UC1903 are generated by creating positive and negative offsets, equal in magnitude, that are referenced to the chip's 2.5-V reference. The resulting fault window is centered around 2.5 V and has a magnitude equal to that of the applied offsets. Simplified schematics of the fault window and reference circuits are shown in Figure 1 along with the Typical Characteristics diagrams. The magnitude of the offsets is determined by the voltage applied at the window adjust pin, Pin 4. A bias cancellation circuit keeps the input current required at Pin 4 low, allowing the use of a simple resistive divider off the reference to set the adjust pin voltage.

The adjust voltage at Pin 4 is internally applied across R4, and an 8-kΩ resistor. The resulting current is mirrored four times to generate current sources I_{OA} , I_{OB} , I_{OC} , and I_{OD} , all equal in magnitude. When all four of the sense inputs are inside the fault window, a no-fault condition, Q4 and Q5 are turned on. In combination with D1 and D2 this prevents L_{OB} and L_{OD} from affecting the fault thresholds. In this case, the OV and UV thresholds are equal to $V_{REF} + I_{OA}(R5 + R6)$ and $V_{REF} - I_{OC}(R7 + R8)$ respectively. The fault window can be expressed as:

$$2.5 \text{ V} \pm \frac{V_{ADJ}}{4} \quad (1)$$

In terms of a sensed nominal voltage level, V_S , the window as a percent variation is:

$$V_S \pm (10 \times V_{ADJ})\% \quad (2)$$

When a sense input moves outside the fault window given in Equation 1, the appropriate hysteresis control signal turns off Q4 or Q5. For the under-voltage case, Q5 is disabled and current source I_{OB} flows through D2. The net current through R7 becomes zero as I_{OB} cancels I_{OC} , giving an 8% reduction in the UV threshold offset. The overvoltage case is the same, with Q4 turning off, allowing I_{OD} to cancel the current flow, I_{OA} , through R6. The result is a hysteresis at the sense inputs which is always 8% of the window magnitude. This is shown graphically in Figure 2.

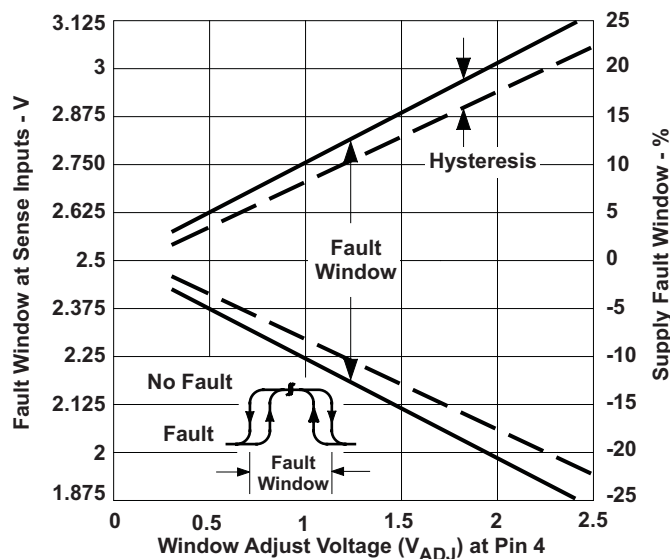
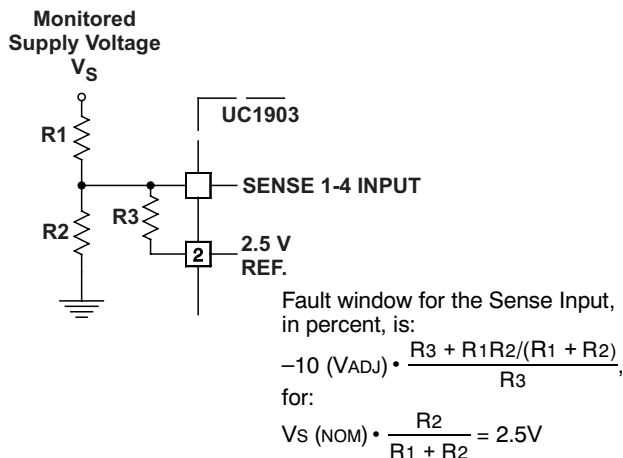

Figure 2. Fault Window and Threshold Hysteresis Scale as a Function of the Voltage Applied at Pin 4

Fault Windows Scaled Independently

In many applications, it may be desirable to monitor various supply voltages, or voltage levels, with varying fault windows. Using the reference output and external resistive dividers this is easily accomplished with the UC1903. Figure 3 and Figure 4 illustrate how the fault window at any sense input can be scaled independently of the remaining inputs.



- A. Using the reference output and a resistive divider, a sense input with an independently wider fault window can be generated.

Figure 3. UC1903 Sense Input with an Independently Wider Fault Window

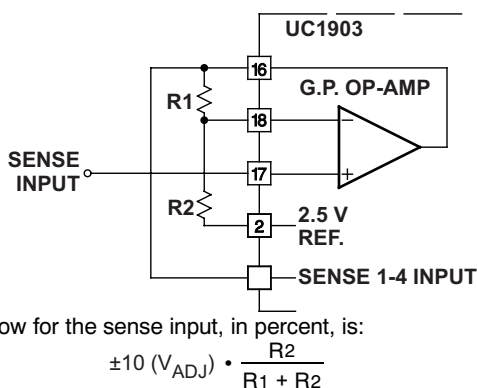

- A. The general purpose op-amp on the UC1903 can be used to create a sense input with an independently tighter fault window.

Figure 4. UC1903 Sense Input with an Independently Tighter Fault Window

Figure 4 demonstrates one of many auxiliary functions that the uncommitted op-amp on the UC1903 can be used for. Alternatively, this op-amp can be used to buffer high impedance points, perform logic functions, or for sensing and amplification. For example, the G.P. op-amp, combined with the 2.5-V reference, can be used to produce and buffer an optically coupled feedback signal in isolated supplies with primary side control. The output stage of this op-amp is detailed in Figure 5. The NPN emitter follower provides high source current capability. ≥ 20 mA while the substrate device, Q3, provides good transient sinking capability.

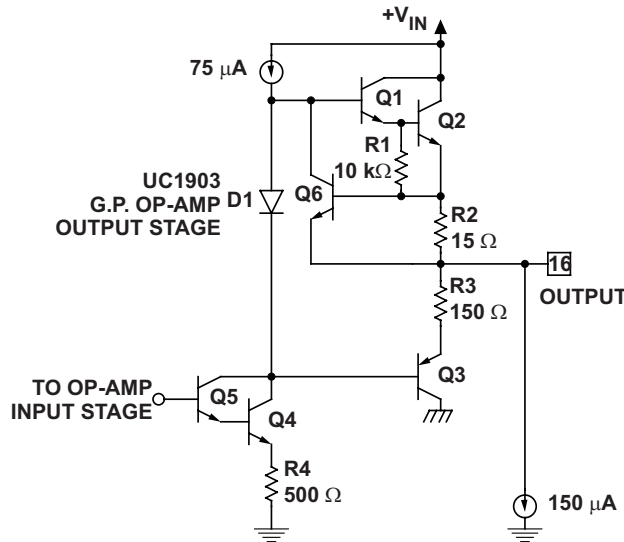

- A. The G.P. op-amp on the UC1903 has a high source current (20 mA) capability and enhanced transient sinking capability through substrate device Q3.

Figure 5. The G.P. Op-Amp on the UC1903

Sensing a Negative Voltage Level

The UC1903 has a dedicated inverter coupled to the sense 4 input. With this inverter, a negative voltage level can be sensed as shown in Figure 6. The output of the inverter is an unbiased emitter follower. By tying the inverting input, Pin 5, high the output emitter follower will be reverse biased, leaving the sense 4 input in a high impedance state. In this manner, the sense 4 input can be used, as the remaining sense inputs would be, for sensing positive voltage levels.

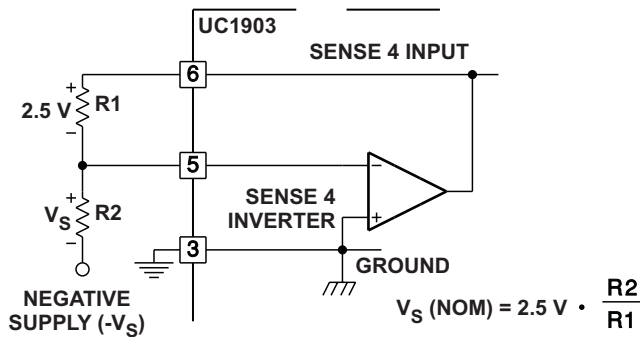

Note: A similar scheme w/the G.P op-amp will allow a second negative supply to be monitored.

Figure 6. Inverting the Sense 4 Input for Monitoring a Negative Supply, Accommodated with the Dedicated Inverter

Using The Line/Switcher Sense Output

The line switcher sense input to the UC1903 can be used for early detection of line, switcher, or other power source, failures. Internally referenced to 2.0 V, the line sense comparator will cause the POWER OK output to indicate a fault (active low) condition when the LINE/SWITCHER SENSE input goes from above to below 2.0 V. The line sense comparator has approximately 175 mV of hysteresis requiring the line/switcher input to reach 2.175 V before the POWER OK output device can be turned off, allowing a no-fault indication. In [Figure 7](#) an example showing the use of the LINE/SWITCHER SENSE input for early switcher-fault detection is detailed. A sample signal is taken from the output of the power transformer, rectified and filtered, and used at the line/switcher input. By adjusting the R_2C time constant with respect to the switching frequency of the supply and the hold up time of the output capacitor, switcher faults can be detected before supply outputs are significantly affected.

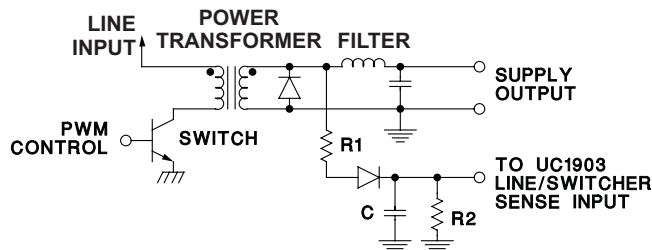
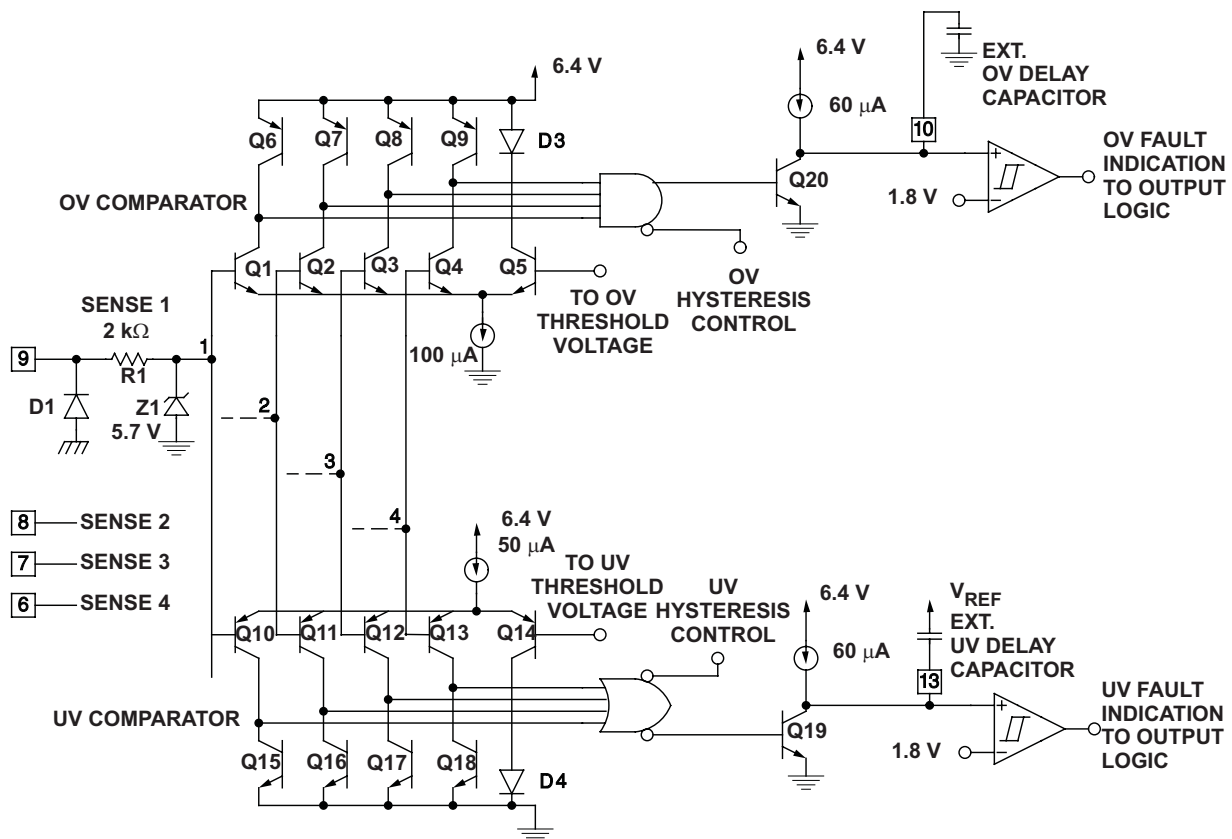

Figure 7. Line/Switcher Sense Input Used for Early Line or Switcher Fault Indication

OV and UV Comparators Maintain Accurate Thresholds

The structure of the \overline{OV} and \overline{UV} comparators, shown in Figure 8 results in accurate fault thresholds even in the case where multiple sense inputs cross a fault threshold simultaneously. Unused sense inputs can be tied either to the 2.5-V reference, or to another, utilized, sense input. The four under- and over-voltage sense inputs on the UC1903 are clamped as detailed on the Sense 1 input in Figure 8. The series 2-k Ω resistor, R1, and zener diode Z1, prevent extreme under- and over-voltage conditions from inverting the outputs of the fault comparators. A parasitic diode, D1, is present at the inputs as well. Under normal operation it is advisable to insure that voltage levels at all of the sense inputs stay above -0.3 V. The same type of input protection exists at the line sense input, Pin 15, except a 5-k Ω series resistor is used.

The fault delay circuitry on the UC1903 is also shown in Figure 8. In the case of an over-voltage condition at one of the sense inputs Q20 is turned off, allowing the internal 60-mA current source to charge the user-selected delay capacitor. When the capacitor voltage reaches 1.8 V, the OV and POWER OK outputs become active low. When the fault condition goes away Q20 is turned back on, rapidly discharging the delay capacitor. Operation of the under- voltage delay is, with appropriate substitutions, the same.



- A. The OV and UV comparators on the UC1903 trigger respective fault delay circuits when one or more of the sense inputs move outside the fault window. Input clamps insure proper operation under extreme fault conditions. Terminating the UV delay capacitor to VREF assures correct logic at power up.

Figure 8. OV and UV Comparators on the UC1903

Start Latch and Supply Under-Voltage Sense Allow Predictable Power-Up

At power-Up, while the $+V_{IN}$ input supply is below 3 V, all open collector outputs are off. With $+V_{IN}$ greater than 3 V the POWER OK output will be driven low and the UV OV FAULT outputs are disabled. Once $+V_{IN}$ rises above the V_{SUV} threshold of 7 V the fault outputs will be enabled. As would be expected, the SENSE 1-4 voltages at power up may be below the UVFAULT window and the UVFAULT output may be driven low.

PACKAGING INFORMATION

Orderable Device	Status (1)	Package Type	Package Drawing	Pins	Package Qty	Eco Plan (2)	Lead/Ball Finish (6)	MSL Peak Temp (3)	Op Temp (°C)	Device Marking (4/5)	Samples
5962-88697012A	ACTIVE	LCCC	FK	20	1	TBD	POST-PLATE	N / A for Pkg Type	-55 to 125	5962-88697012A UC1903L/ 883B	Samples
5962-8869701VA	ACTIVE	CDIP	J	18	1	TBD	A42	N / A for Pkg Type	-55 to 125	5962-8869701VA UC1903J/883B	Samples
UC1903J	ACTIVE	CDIP	J	18	1	TBD	A42	N / A for Pkg Type	-55 to 125	UC1903J	Samples
UC1903J883B	ACTIVE	CDIP	J	18	1	TBD	A42	N / A for Pkg Type	-55 to 125	5962-8869701VA UC1903J/883B	Samples
UC1903L	ACTIVE	LCCC	FK	20	1	TBD	POST-PLATE	N / A for Pkg Type	-55 to 125	UC1903L	Samples
UC1903L883B	ACTIVE	LCCC	FK	20	1	TBD	POST-PLATE	N / A for Pkg Type	-55 to 125	5962-88697012A UC1903L/ 883B	Samples
UC2903DW	ACTIVE	SOIC	DW	18	40	Green (RoHS & no Sb/Br)	CU NIPDAU	Level-2-260C-1 YEAR	-40 to 85	UC2903DW	Samples
UC2903DWG4	ACTIVE	SOIC	DW	18	40	Green (RoHS & no Sb/Br)	CU NIPDAU	Level-2-260C-1 YEAR	-40 to 85	UC2903DW	Samples
UC2903DWTR	ACTIVE	SOIC	DW	18	2000	Green (RoHS & no Sb/Br)	CU NIPDAU	Level-2-260C-1 YEAR	-40 to 85	UC2903DW	Samples
UC2903Q	NRND	PLCC	FN	20	46	Green (RoHS & no Sb/Br)	CU SN	Level-2-260C-1 YEAR	-40 to 85	UC2903Q	
UC3903DW	ACTIVE	SOIC	DW	18	40	Green (RoHS & no Sb/Br)	CU NIPDAU	Level-2-260C-1 YEAR	0 to 70	UC3903DW	Samples
UC3903DWTR	ACTIVE	SOIC	DW	18	2000	Green (RoHS & no Sb/Br)	CU NIPDAU	Level-2-260C-1 YEAR	0 to 70	UC3903DW	Samples
UC3903Q	NRND	PLCC	FN	20	46	Green (RoHS & no Sb/Br)	CU SN	Level-2-260C-1 YEAR	0 to 70	UC3903Q	
UC3903QG3	NRND	PLCC	FN	20	46	Green (RoHS & no Sb/Br)	CU SN	Level-2-260C-1 YEAR	0 to 70	UC3903Q	

(1) The marketing status values are defined as follows:

ACTIVE: Product device recommended for new designs.

LIFEBUY: TI has announced that the device will be discontinued, and a lifetime-buy period is in effect.

NRND: Not recommended for new designs. Device is in production to support existing customers, but TI does not recommend using this part in a new design.

PREVIEW: Device has been announced but is not in production. Samples may or may not be available.

OBSOLETE: TI has discontinued the production of the device.

⁽²⁾ **RoHS:** TI defines "RoHS" to mean semiconductor products that are compliant with the current EU RoHS requirements for all 10 RoHS substances, including the requirement that RoHS substance do not exceed 0.1% by weight in homogeneous materials. Where designed to be soldered at high temperatures, "RoHS" products are suitable for use in specified lead-free processes. TI may reference these types of products as "Pb-Free".

RoHS Exempt: TI defines "RoHS Exempt" to mean products that contain lead but are compliant with EU RoHS pursuant to a specific EU RoHS exemption.

Green: TI defines "Green" to mean the content of Chlorine (Cl) and Bromine (Br) based flame retardants meet JS709B low halogen requirements of ≤ 1000 ppm threshold. Antimony trioxide based flame retardants must also meet the ≤ 1000 ppm threshold requirement.

⁽³⁾ **MSL, Peak Temp.** - The Moisture Sensitivity Level rating according to the JEDEC industry standard classifications, and peak solder temperature.

⁽⁴⁾ There may be additional marking, which relates to the logo, the lot trace code information, or the environmental category on the device.

⁽⁵⁾ Multiple Device Markings will be inside parentheses. Only one Device Marking contained in parentheses and separated by a "~" will appear on a device. If a line is indented then it is a continuation of the previous line and the two combined represent the entire Device Marking for that device.

⁽⁶⁾ **Lead/Ball Finish** - Orderable Devices may have multiple material finish options. Finish options are separated by a vertical ruled line. Lead/Ball Finish values may wrap to two lines if the finish value exceeds the maximum column width.

Important Information and Disclaimer: The information provided on this page represents TI's knowledge and belief as of the date that it is provided. TI bases its knowledge and belief on information provided by third parties, and makes no representation or warranty as to the accuracy of such information. Efforts are underway to better integrate information from third parties. TI has taken and continues to take reasonable steps to provide representative and accurate information but may not have conducted destructive testing or chemical analysis on incoming materials and chemicals. TI and TI suppliers consider certain information to be proprietary, and thus CAS numbers and other limited information may not be available for release.

In no event shall TI's liability arising out of such information exceed the total purchase price of the TI part(s) at issue in this document sold by TI to Customer on an annual basis.

OTHER QUALIFIED VERSIONS OF UC1903, UC3903 :

● Catalog: [UC3903](#)

● Military: [UC1903](#)

NOTE: Qualified Version Definitions:

● Catalog - TI's standard catalog product

- Military - QML certified for Military and Defense Applications

TAPE AND REEL INFORMATION

QUADRANT ASSIGNMENTS FOR PIN 1 ORIENTATION IN TAPE

*All dimensions are nominal

Device	Package Type	Package Drawing	Pins	SPQ	Reel Diameter (mm)	Reel Width W1 (mm)	A0 (mm)	B0 (mm)	K0 (mm)	P1 (mm)	W (mm)	Pin1 Quadrant
UC2903DWTR	SOIC	DW	18	2000	330.0	24.4	10.9	12.0	2.7	12.0	24.0	Q1
UC3903DWTR	SOIC	DW	18	2000	330.0	24.4	10.9	12.0	2.7	12.0	24.0	Q1

TAPE AND REEL BOX DIMENSIONS

*All dimensions are nominal

Device	Package Type	Package Drawing	Pins	SPQ	Length (mm)	Width (mm)	Height (mm)
UC2903DWTR	SOIC	DW	18	2000	367.0	367.0	45.0
UC3903DWTR	SOIC	DW	18	2000	367.0	367.0	45.0

IMPORTANT NOTICE

Texas Instruments Incorporated (TI) reserves the right to make corrections, enhancements, improvements and other changes to its semiconductor products and services per JESD46, latest issue, and to discontinue any product or service per JESD48, latest issue. Buyers should obtain the latest relevant information before placing orders and should verify that such information is current and complete.

TI's published terms of sale for semiconductor products (<http://www.ti.com/sc/docs/stdterms.htm>) apply to the sale of packaged integrated circuit products that TI has qualified and released to market. Additional terms may apply to the use or sale of other types of TI products and services.

Reproduction of significant portions of TI information in TI data sheets is permissible only if reproduction is without alteration and is accompanied by all associated warranties, conditions, limitations, and notices. TI is not responsible or liable for such reproduced documentation. Information of third parties may be subject to additional restrictions. Resale of TI products or services with statements different from or beyond the parameters stated by TI for that product or service voids all express and any implied warranties for the associated TI product or service and is an unfair and deceptive business practice. TI is not responsible or liable for any such statements.

Buyers and others who are developing systems that incorporate TI products (collectively, "Designers") understand and agree that Designers remain responsible for using their independent analysis, evaluation and judgment in designing their applications and that Designers have full and exclusive responsibility to assure the safety of Designers' applications and compliance of their applications (and of all TI products used in or for Designers' applications) with all applicable regulations, laws and other applicable requirements. Designer represents that, with respect to their applications, Designer has all the necessary expertise to create and implement safeguards that (1) anticipate dangerous consequences of failures, (2) monitor failures and their consequences, and (3) lessen the likelihood of failures that might cause harm and take appropriate actions. Designer agrees that prior to using or distributing any applications that include TI products, Designer will thoroughly test such applications and the functionality of such TI products as used in such applications.

TI's provision of technical, application or other design advice, quality characterization, reliability data or other services or information, including, but not limited to, reference designs and materials relating to evaluation modules, (collectively, "TI Resources") are intended to assist designers who are developing applications that incorporate TI products; by downloading, accessing or using TI Resources in any way, Designer (individually or, if Designer is acting on behalf of a company, Designer's company) agrees to use any particular TI Resource solely for this purpose and subject to the terms of this Notice.

TI's provision of TI Resources does not expand or otherwise alter TI's applicable published warranties or warranty disclaimers for TI products, and no additional obligations or liabilities arise from TI providing such TI Resources. TI reserves the right to make corrections, enhancements, improvements and other changes to its TI Resources. TI has not conducted any testing other than that specifically described in the published documentation for a particular TI Resource.

Designer is authorized to use, copy and modify any individual TI Resource only in connection with the development of applications that include the TI product(s) identified in such TI Resource. NO OTHER LICENSE, EXPRESS OR IMPLIED, BY ESTOPPEL OR OTHERWISE TO ANY OTHER TI INTELLECTUAL PROPERTY RIGHT, AND NO LICENSE TO ANY TECHNOLOGY OR INTELLECTUAL PROPERTY RIGHT OF TI OR ANY THIRD PARTY IS GRANTED HEREIN, including but not limited to any patent right, copyright, mask work right, or other intellectual property right relating to any combination, machine, or process in which TI products or services are used. Information regarding or referencing third-party products or services does not constitute a license to use such products or services, or a warranty or endorsement thereof. Use of TI Resources may require a license from a third party under the patents or other intellectual property of the third party, or a license from TI under the patents or other intellectual property of TI.

TI RESOURCES ARE PROVIDED "AS IS" AND WITH ALL FAULTS. TI DISCLAIMS ALL OTHER WARRANTIES OR REPRESENTATIONS, EXPRESS OR IMPLIED, REGARDING RESOURCES OR USE THEREOF, INCLUDING BUT NOT LIMITED TO ACCURACY OR COMPLETENESS, TITLE, ANY EPIDEMIC FAILURE WARRANTY AND ANY IMPLIED WARRANTIES OF MERCHANTABILITY, FITNESS FOR A PARTICULAR PURPOSE, AND NON-INFRINGEMENT OF ANY THIRD PARTY INTELLECTUAL PROPERTY RIGHTS. TI SHALL NOT BE LIABLE FOR AND SHALL NOT DEFEND OR INDEMNIFY DESIGNER AGAINST ANY CLAIM, INCLUDING BUT NOT LIMITED TO ANY INFRINGEMENT CLAIM THAT RELATES TO OR IS BASED ON ANY COMBINATION OF PRODUCTS EVEN IF DESCRIBED IN TI RESOURCES OR OTHERWISE. IN NO EVENT SHALL TI BE LIABLE FOR ANY ACTUAL, DIRECT, SPECIAL, COLLATERAL, INDIRECT, PUNITIVE, INCIDENTAL, CONSEQUENTIAL OR EXEMPLARY DAMAGES IN CONNECTION WITH OR ARISING OUT OF TI RESOURCES OR USE THEREOF, AND REGARDLESS OF WHETHER TI HAS BEEN ADVISED OF THE POSSIBILITY OF SUCH DAMAGES.

Unless TI has explicitly designated an individual product as meeting the requirements of a particular industry standard (e.g., ISO/TS 16949 and ISO 26262), TI is not responsible for any failure to meet such industry standard requirements.

Where TI specifically promotes products as facilitating functional safety or as compliant with industry functional safety standards, such products are intended to help enable customers to design and create their own applications that meet applicable functional safety standards and requirements. Using products in an application does not by itself establish any safety features in the application. Designers must ensure compliance with safety-related requirements and standards applicable to their applications. Designer may not use any TI products in life-critical medical equipment unless authorized officers of the parties have executed a special contract specifically governing such use. Life-critical medical equipment is medical equipment where failure of such equipment would cause serious bodily injury or death (e.g., life support, pacemakers, defibrillators, heart pumps, neurostimulators, and implantables). Such equipment includes, without limitation, all medical devices identified by the U.S. Food and Drug Administration as Class III devices and equivalent classifications outside the U.S.

TI may expressly designate certain products as completing a particular qualification (e.g., Q100, Military Grade, or Enhanced Product). Designers agree that it has the necessary expertise to select the product with the appropriate qualification designation for their applications and that proper product selection is at Designers' own risk. Designers are solely responsible for compliance with all legal and regulatory requirements in connection with such selection.

Designer will fully indemnify TI and its representatives against any damages, costs, losses, and/or liabilities arising out of Designer's non-compliance with the terms and provisions of this Notice.

Looking for pricing, stock, or lifecycle information?

Click below to explore more details on WIN SOURCE:

 [View UC3903Q on WIN SOURCE](#)

 [Texas Instruments](#) Information

Optimize Your Supply Chain with WIN SOURCE Solutions

-  Global Sourcing Solution
-  Obsolete Management
-  Cost Control Management
-  Shortage Management
-  Alternative Solution
-  Excess Inventory Management