



**ULN2002A/ULN2003A/ULN2004A**

**HIGH-VOLTAGE, HIGH-CURRENT  
DARLINGTON TRANSISTOR ARRAYS**

**Description**

The ULN2002A, ULN2003A, and ULN2004A are high-voltage, high-current Darlington arrays each containing seven open collector common emitter pairs. Each pair is rated at 500mA. Suppression diodes are included for inductive load driving. The inputs and outputs are pinned in opposition to simplify board layout.

Device options are designed to be compatible with common logic families:

- ULN2002A (14V to 25V PMOS)
- ULN2003A (5V TTL, CMOS)
- ULN2004A (6V to 15V CMOS, PMOS)

These devices are capable of driving a wide range of loads including solenoids, relays, DC motors, LED displays, filament lamps, thermal print-heads, and high-power buffers.

The ULN2002A, ULN2003A, and ULN2004A are available in both a small outline 16-pin package (SO-16) and a PDIP-16 package. The ULN2003A has an additional TSSOP-16 (Type CJ) package available for small footprint requirements.

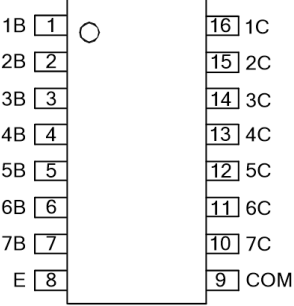
**Features**

- 500mA Rated Collector Current (Single Output)
- High-Voltage Outputs: 50V
- Output Clamp Diodes
- Inputs Compatible with Popular Logic Types
- Relay Driver Applications
- “Green” Molding Compound (No Br, Sb)
- **Totally Lead-Free & Fully RoHS Compliant (Notes 1 & 2)**
- **Halogen and Antimony Free. “Green” Device (Note 3)**
- **For automotive applications requiring specific change control (i.e. parts qualified to AEC-Q100/101/104/200, PPAP capable, and manufactured in IATF 16949 certified facilities), please [contact us](mailto:contact@diodes.com) or your local Diodes representative. <https://www.diodes.com/quality/product-definitions/>**

Notes: 1. No purposely added lead. Fully EU Directive 2002/95/EC (RoHS), 2011/65/EU (RoHS 2) & 2015/863/EU (RoHS 3) compliant.  
 2. See <https://www.diodes.com/quality/lead-free/> for more information about Diodes Incorporated’s definitions of Halogen- and Antimony-free, “Green” and Lead-free.  
 3. Halogen- and Antimony-free “Green” products are defined as those which contain <900ppm bromine, <900ppm chlorine (<1500ppm total Br + Cl) and <1000ppm antimony compounds.

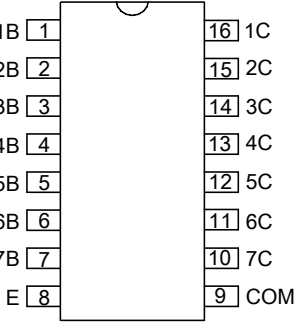
**Pin Assignments**

(Top View)



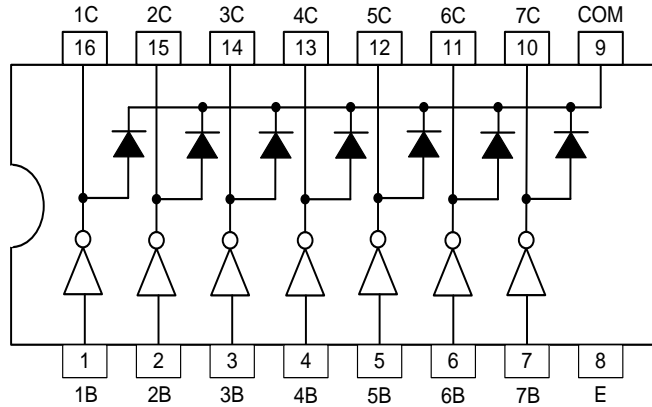
SO-16  
TSSOP-16 (Type CJ) (ULN2003A Only)

(Top View)



PDIP-16

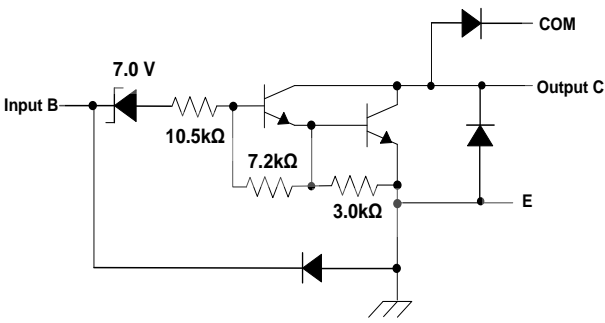
**Connection Diagram**



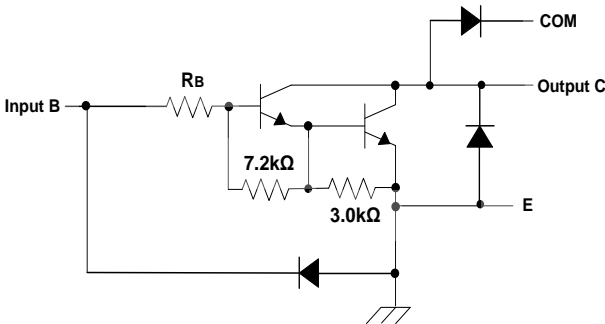
**Pin Descriptions**

Pin Number	Pin Name	Function
SO-16/PDIP-16/TSSOP-16 (Type CJ)		
1	1B	Input Pair 1
2	2B	Input Pair 2
3	3B	Input Pair 3
4	4B	Input Pair 4
5	5B	Input Pair 5
6	6B	Input Pair 6
7	7B	Input Pair 7
8	E	Common Emitter (Ground)
9	COM	Common Clamp Diodes
10	7C	Output Pair 7
11	6C	Output Pair 6
12	5C	Output Pair 5
13	4C	Output Pair 4
14	3C	Output Pair 3
15	2C	Output Pair 2
16	1C	Output Pair 1

**Functional Block Diagram**



ULN2002A



ULN2003A:  $R_B = 2.7k$   
 ULN2004A:  $R_B = 10.5k$

ULN2003A/ULN2004A

**Absolute Maximum Ratings** (Note 4) (@T<sub>A</sub> = +25°C, unless otherwise specified.)

Symbol	Parameter		Rating	Unit
V <sub>CC</sub>	Collector to Emitter Voltage		50	V
V <sub>R</sub>	Clamp Diode Reverse Voltage (Note 5)		50	V
V <sub>I</sub>	Input Voltage (Note 5)		30	V
I <sub>CP</sub>	Peak Collector Current		500	mA
I <sub>OK</sub>	Output Clamp Current		500	mA
I <sub>TE</sub>	Total Emitter Current		-2.5	A
θ <sub>JA</sub>	Thermal Resistance Junction-to-Ambient (Note 6)	SO-16	63.0	°C/W
		TSSOP-16 (Type CJ) (ULN2003A)	98	
		PDIP-16	50.0	
θ <sub>JC</sub>	Thermal Resistance Junction-to-Case (Note 7)	SO-16	12.0	°C/W
		TSSOP-16 (Type CJ) (ULN2003A)	31	
		PDIP-16	15.0	
ESD	HBM	2	kV	
	CDM	2	kV	
T <sub>J</sub>	Junction Temperature		+150	°C
T <sub>STG</sub>	Storage Temperature		-65 to +150	°C

- Notes:
- Stresses greater than those listed under *Absolute Maximum Ratings* can cause permanent damage to the device. These are stress ratings only, and functional operation of the device at these or any other conditions beyond those indicated under *Recommended Operating Conditions* is not implied. Exposure to *Absolute Maximum Ratings* for extended periods can affect device reliability.
  - All voltage values are with respect to the emitter/substrate terminal E, unless otherwise noted.
  - Maximum power dissipation is a function of T<sub>J</sub>(max), θ<sub>JA</sub> and T<sub>A</sub>. The maximum allowable power dissipation at any allowable ambient temperature is P<sub>D</sub> = (T<sub>J</sub>(max) - T<sub>A</sub>)/θ<sub>JA</sub>. Operating at the absolute maximum T<sub>J</sub> of +150°C can affect reliability.
  - Maximum power dissipation is a function of T<sub>J</sub>(max), θ<sub>JC</sub> and T<sub>A</sub>. The maximum allowable power dissipation at any allowable ambient temperature is P<sub>D</sub> = (T<sub>J</sub>(max) - T<sub>C</sub>)/θ<sub>JC</sub>. Operating at the absolute maximum T<sub>J</sub> of +150°C can affect reliability.

**Recommended Operating Conditions**

Symbol	Parameter	Min	Max	Unit
V <sub>CC</sub>	Collector to Emitter Voltage	0	50	V
T <sub>A</sub>	Operating Ambient Temperature	-40	+105	°C

**Electrical Characteristics** (@T<sub>A</sub> = +25°C, unless otherwise specified.)

ULN2002A								
Symbol	Parameter	Test Figure	Test Conditions	Min	Typ	Max	Unit	
V <sub>I(ON)</sub>	On-State Input Voltage	6	V <sub>CE</sub> = 2V, I <sub>C</sub> = 300mA	—	—	13	V	
V <sub>CE(SAT)</sub>	Collector Emitter Saturation Voltage	5	I <sub>I</sub> = 250μA, I <sub>C</sub> = 100mA	—	0.9	1.1	V	
			I <sub>I</sub> = 350μA, I <sub>C</sub> = 200mA	—	1	1.3		
			I <sub>I</sub> = 500μA, I <sub>C</sub> = 350mA	—	1.2	1.6		
V <sub>F</sub>	Clamp Forward Voltage	8	I <sub>F</sub> = 350mA	—	1.7	2	V	
I <sub>CEX</sub>	Collector Cut-Off Current	1	V <sub>CE</sub> = 50V, I <sub>I</sub> = 0	—	—	50	μA	
		2	V <sub>CE</sub> = 50V T <sub>A</sub> = +105°C	I <sub>I</sub> = 0 V <sub>I</sub> = 6V	—	—		100 500
I <sub>I(OFF)</sub>	Off-State Input Current	3	V <sub>CE</sub> = 50V, I <sub>C</sub> = 500μA	50	65	—	μA	
I <sub>I</sub>	Input Current	4	V <sub>I</sub> = 17V	—	0.82	1.25	mA	
I <sub>R</sub>	Clamp Reverse Current	7	V <sub>R</sub> = 50V	T <sub>A</sub> = +105°C	—	—	100	μA
				—	—	—	50	
C <sub>I</sub>	Input Capacitance	—	V <sub>I</sub> = 0, f = 1MHz	—	—	25	pF	

**Electrical Characteristics** (continued) (@T<sub>A</sub> = +25°C, unless otherwise specified.)

ULN2003A								
Parameter		Test Figure	Test Conditions	Min	Typ	Max	Unit	
V <sub>I(ON)</sub>	On-State Input Voltage	6	V <sub>CE</sub> = 2V	I <sub>C</sub> = 200mA	—	—	2.4	V
				I <sub>C</sub> = 250mA	—	—	2.7	
				I <sub>C</sub> = 300mA	—	—	3	
V <sub>CE(SAT)</sub>	Collector Emitter Saturation Voltage	5		I <sub>I</sub> = 250μA, I <sub>C</sub> = 100mA	—	0.9	1.1	V
				I <sub>I</sub> = 350μA, I <sub>C</sub> = 200mA	—	1	1.3	
				I <sub>I</sub> = 500μA, I <sub>C</sub> = 350mA	—	1.2	1.6	
V <sub>F</sub>	Clamp Forward Voltage	8	I <sub>F</sub> = 350mA	—	1.7	2	V	
I <sub>CEX</sub>	Collector Cut-Off Current	1	V <sub>CE</sub> = 50V, I <sub>I</sub> = 0	—	—	50	μA	
		2	V <sub>CE</sub> = 50V T <sub>A</sub> = +105°C	I <sub>I</sub> = 0	—	—		100
I <sub>I(OFF)</sub>	Off-State Input Current	3	V <sub>CE</sub> = 50V, I <sub>C</sub> = 500μA	50	65	—	μA	
I <sub>I</sub>	Input Current	4	V <sub>I</sub> = 3.85V	—	0.93	1.35	mA	
I <sub>R</sub>	Clamp Reverse Current	7	V <sub>R</sub> = 50V	T <sub>A</sub> = +105°C	—	—	100	μA
				—	—	—	50	
C <sub>I</sub>	Input Capacitance	—	V <sub>I</sub> = 0, f = 1MHz	—	15	25	pF	
ULN2004A								
Parameter		Test Figure	Test Conditions	Min	Typ	Max	Unit	
V <sub>I(ON)</sub>	On-State Input Voltage	6	V <sub>CE</sub> = 2V	I <sub>C</sub> = 125mA	—	—	5	V
				I <sub>C</sub> = 200mA	—	—	6	
				I <sub>C</sub> = 275mA	—	—	7	
				I <sub>C</sub> = 350mA	—	—	8	
V <sub>CE(SAT)</sub>	Collector Emitter Saturation Voltage	5		I <sub>I</sub> = 250μA, I <sub>C</sub> = 100mA	—	0.9	1.1	V
				I <sub>I</sub> = 350μA, I <sub>C</sub> = 200mA	—	1	1.3	
				I <sub>I</sub> = 500μA, I <sub>C</sub> = 350mA	—	1.2	1.6	
V <sub>F</sub>	Clamp Forward Voltage	8	I <sub>F</sub> = 350mA	—	1.7	2	V	
I <sub>CEX</sub>	Collector Cut-Off Current	1	V <sub>CE</sub> = 50V, I <sub>I</sub> = 0	—	—	50	μA	
		2	V <sub>CE</sub> = 50V T <sub>A</sub> = +105°C	I <sub>I</sub> = 0 V <sub>I</sub> = 6V	—	—		100 500
I <sub>I(OFF)</sub>	Off-State Input Current	3	V <sub>CE</sub> = 50V, I <sub>C</sub> = 500μA	50	65	—	μA	
I <sub>I</sub>	Input Current	4	V <sub>I</sub> = 5V	—	0.35	0.5	mA	
I <sub>R</sub>	Clamp Reverse Current	7	V <sub>R</sub> = 50V	T <sub>A</sub> = +105°C	—	—	100	μA
				—	—	—	50	
C <sub>I</sub>	Input Capacitance	—	V <sub>I</sub> = 0, f = 1MHz	—	15	25	pF	

**Electrical Characteristics** (@T<sub>A</sub> = -40°C to +105°C, unless otherwise specified.)

ULN2003A								
Parameter		Test Figure	Test Conditions	Min	Typ	Max	Unit	
V <sub>I(ON)</sub>	On-State Input Voltage	6	V <sub>CE</sub> = 2V	I <sub>C</sub> = 200mA	—	—	2.7	V
				I <sub>C</sub> = 250mA	—	—	2.9	
				I <sub>C</sub> = 300mA	—	—	3	
V <sub>CE(SAT)</sub>	Collector Emitter Saturation Voltage	5	I <sub>I</sub> = 250μA, I <sub>C</sub> = 100mA	—	0.9	1.2	V	
			I <sub>I</sub> = 350μA, I <sub>C</sub> = 200mA	—	1	1.4		
			I <sub>I</sub> = 500μA, I <sub>C</sub> = 350mA	—	1.2	1.7		
V <sub>F</sub>	Clamp Forward Voltage	8	I <sub>F</sub> = 350mA	—	1.7	2.2	V	
I <sub>CEX</sub>	Collector Cut-Off Current	1	V <sub>CE</sub> = 50V, I <sub>I</sub> = 0	—	—	100	μA	
I <sub>I(OFF)</sub>	Off-State Input Current	3	V <sub>CE</sub> = 50V, I <sub>C</sub> = 500μA	30	65	—	μA	
I <sub>I</sub>	Input Current	4	V <sub>I</sub> = 3.85V	—	0.93	1.35	mA	
I <sub>R</sub>	Clamp Reverse Current	7	V <sub>R</sub> = 50V	—	—	100	μA	
C <sub>I</sub>	Input Capacitance	—	V <sub>I</sub> = 0, f = 1MHz	—	15	25	pF	

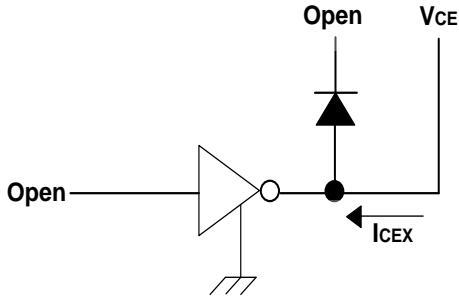
**Switching Characteristics** (@T<sub>A</sub> = +25°C, unless otherwise specified.)

ULN2002A/ULN2003A/ULN2004A						
Parameter		Test Figure	Min	Typ	Max	Unit
t <sub>PLH</sub>	Propagation Delay Time, Low to High-Level Output	9	—	0.25	1	μs
t <sub>PHL</sub>	Propagation Delay Time, High to Low-Level Output	9	—	0.25	1	μs
V <sub>OH</sub>	High-Level Output Voltage after Switching	9 (V <sub>S</sub> = 50V, I <sub>O</sub> = 300mA)	V <sub>S</sub> -20	—	—	mV

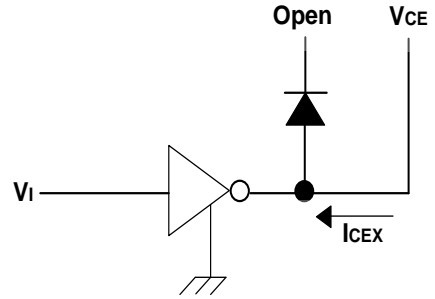
**Switching Characteristics** (@T<sub>A</sub> = -40 to +105°C, unless otherwise specified.)

ULN2003A						
Parameter		Test Figure	Min	Typ	Max	Unit
t <sub>PLH</sub>	Propagation Delay Time, Low to High-Level Output	9	—	1	10	μs
t <sub>PHL</sub>	Propagation Delay Time, High to Low-Level Output	9	—	1	10	μs
V <sub>OH</sub>	High-Level Output Voltage after Switching	9 (V <sub>S</sub> = 50V, I <sub>O</sub> = 300mA)	V <sub>S</sub> -50	—	—	mV

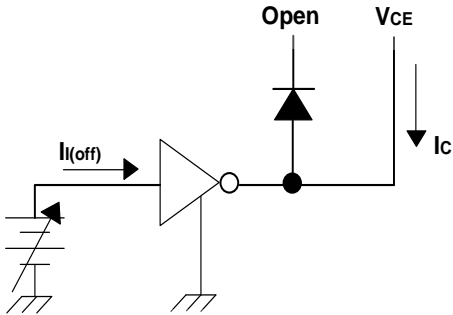
**Parameter Measurement Circuits**



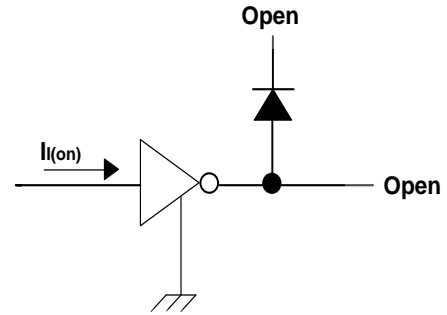
**Fig.1 ICEX Test Circuit**



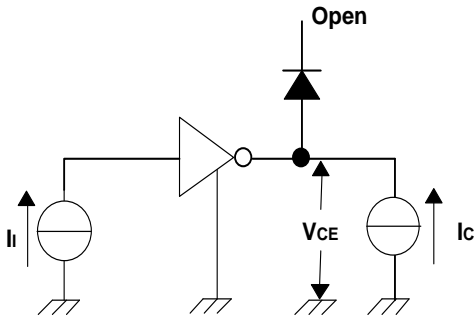
**Fig.2 ICEX Test Circuit**



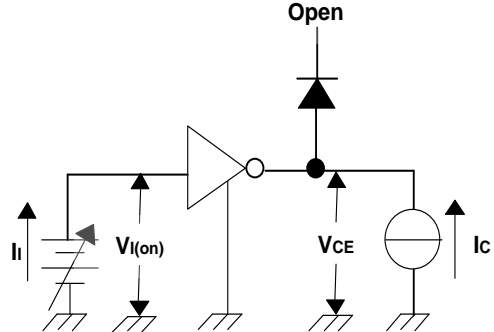
**Fig.3 I(off) Test Circuit**



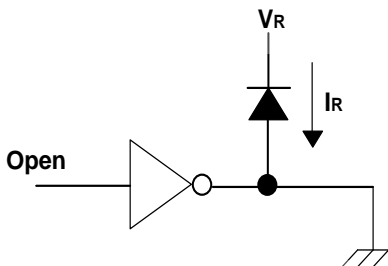
**Fig.4 I(on) Test Circuit**



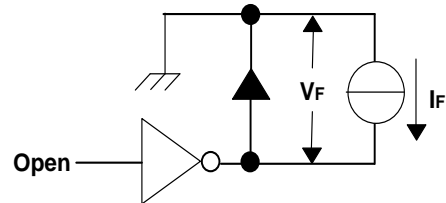
**Fig. 5 hFE , VCE(sat) Test Circuit**



**Fig. 6 V(on) Test Circuit**

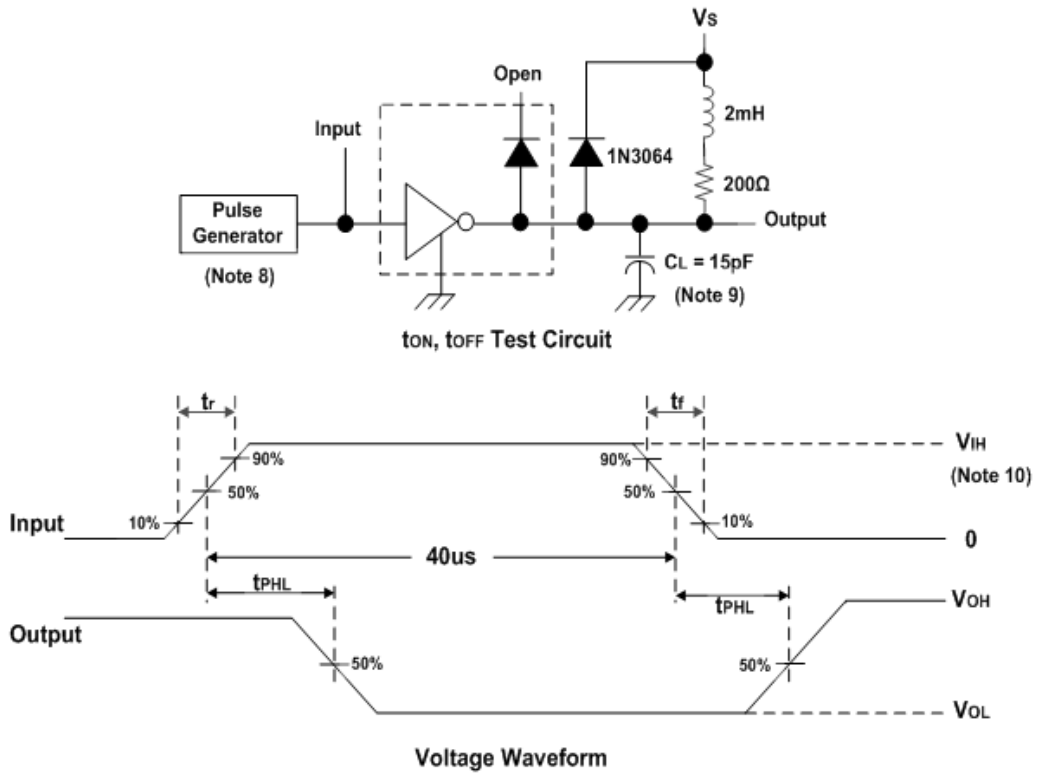


**Fig. 7 IR Test Circuit**



**Fig. 8 VF Test Circuit**

**Parameter Measurement Circuits** (continued)

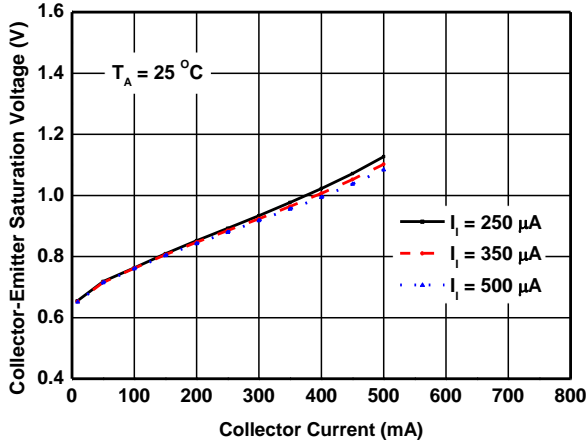


**Fig. 9 Latchup Test Circuit and Voltage Waveform**

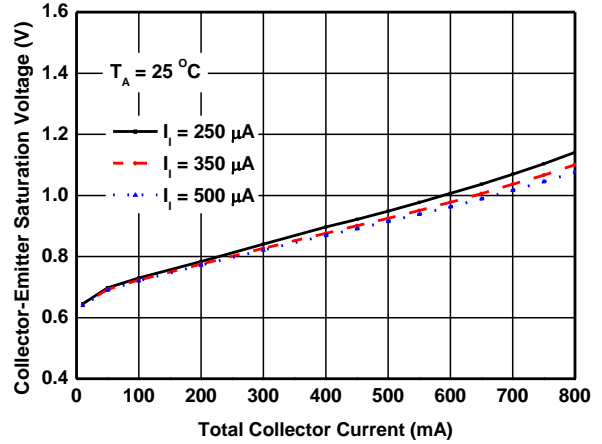
- Notes:
- 8. The pulse generator has the following characteristics: Pulse width = 12.5Hz, output impedance 50Ω, t<sub>r</sub> ≤ 5ns, t<sub>f</sub> ≤ 10ns.
  - 9. C<sub>L</sub> includes probe and jig capacitance.
  - 10. For testing the ULN2002A, V<sub>IH</sub> = 13V; for the ULN2003A, V<sub>IH</sub> = 3V; for the ULN2004A, V<sub>IH</sub> = 8V.

**Typical Performance Characteristics**

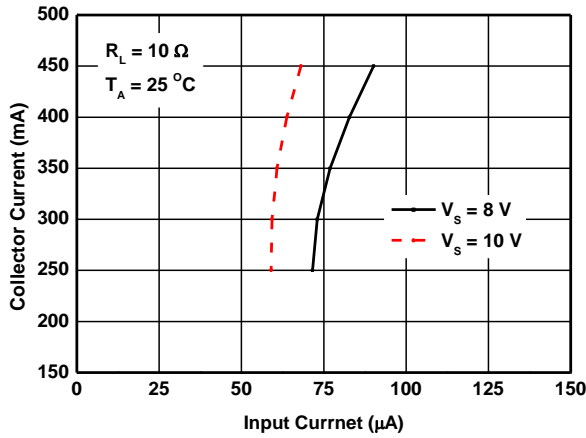
**Collector-Emitter Saturation Voltage vs. Collector Current (One Darlington)**



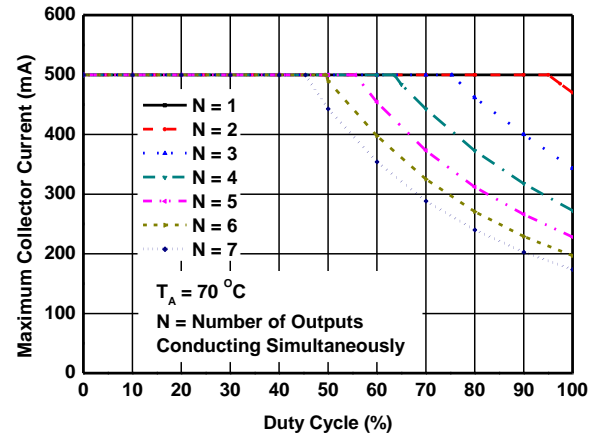
**Collector-Emitter Saturation Voltage vs. Collector Current (Two Darlington in Parallel)**



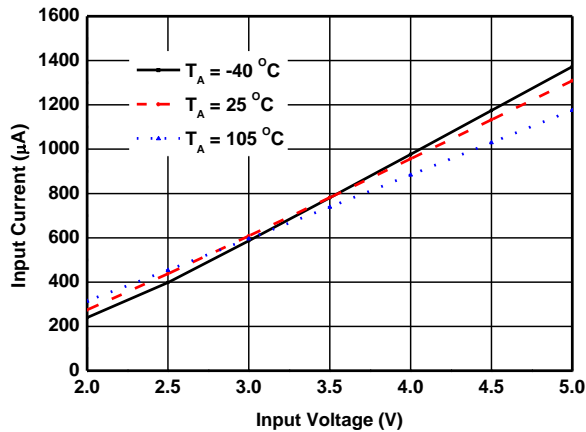
**Collector Current vs. Input Current**



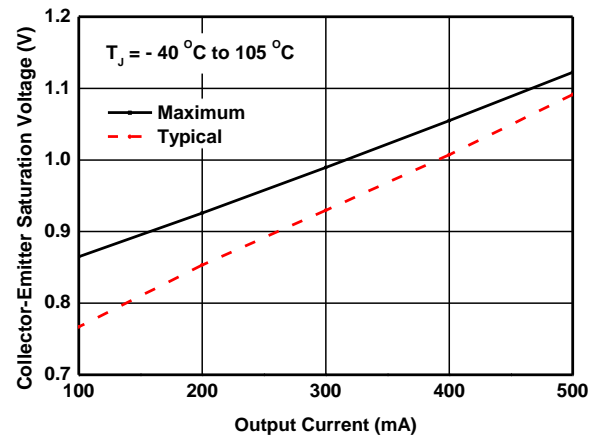
**Maximum Collector Current vs. Duty Cycle**



**Input Current vs. Input Voltage**

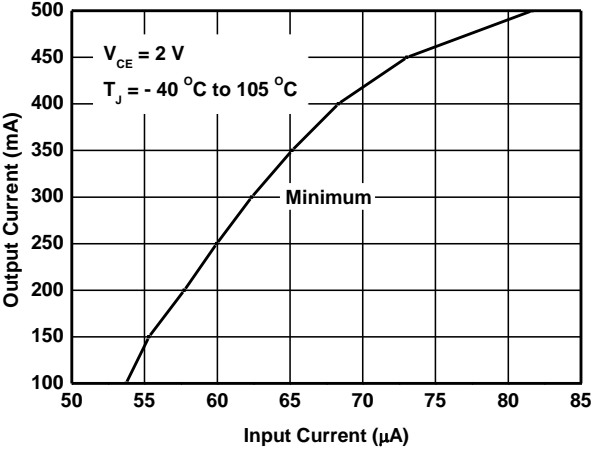


**Collector-Emitter Saturation Voltage vs. Output Current**

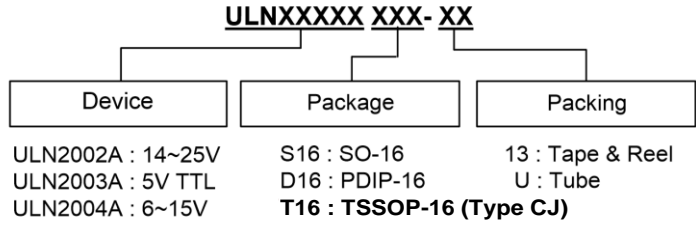


**Typical Performance Characteristics** (continued)

Output Current vs. Input Current



## Ordering Information

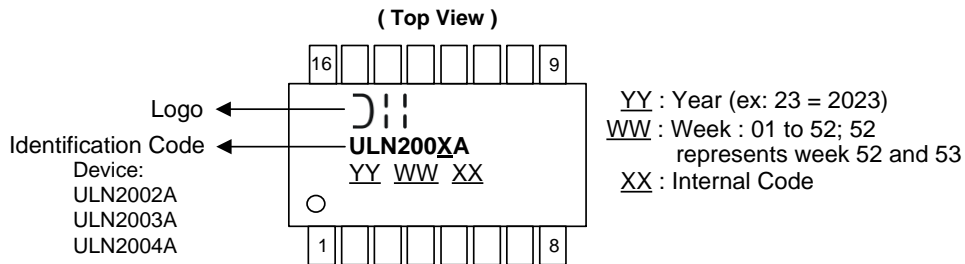


Part Number	Part Number Suffix	Package Code	Package	Status	Packing	
					Qty.	Carrier
ULN2002AS16-13	-13	S16	SO-16	Production	2,500	13" Tape and Reel
ULN2003AS16-13	-13	S16	SO-16	Production	2,500	13" Tape and Reel
ULN2004AS16-13	-13	S16	SO-16	Production	2,500	13" Tape and Reel
ULN2002AD16-U	-U	D16	PDIP-16	EOL*	25	Tube
ULN2003AD16-U	-U	D16	PDIP-16	EOL*	25	Tube
ULN2004AD16-U	-U	D16	PDIP-16	EOL*	25	Tube
ULN2003AT16-13	-13	T16	TSSOP-16 (Type CJ)	Production	2,500	13" Tape and Reel

\* EOL = End of life. Please [contact us](#).

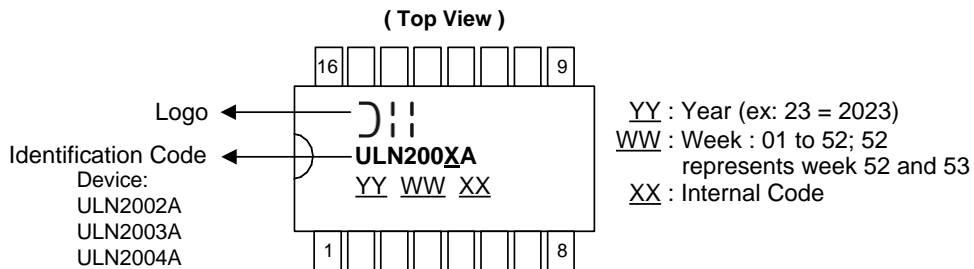
## Marking Information

### (1) SO-16, TSSOP-16 (Type CJ)



Part Number	Package	Identification Code
ULN200xAS16-13	SO-16	ULN200xA
ULN2003AT16-13	TSSOP-16 (Type CJ)	ULN2003A

### (2) PDIP-16

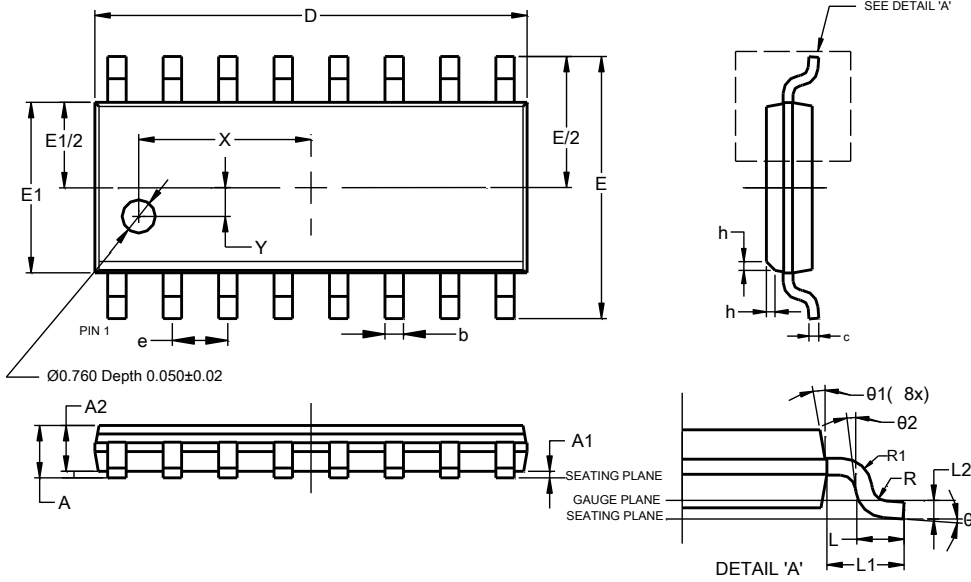


Part Number	Package	Identification Code
ULN200xAD16-U	PDIP-16	ULN200xA

**Package Outline Dimensions**

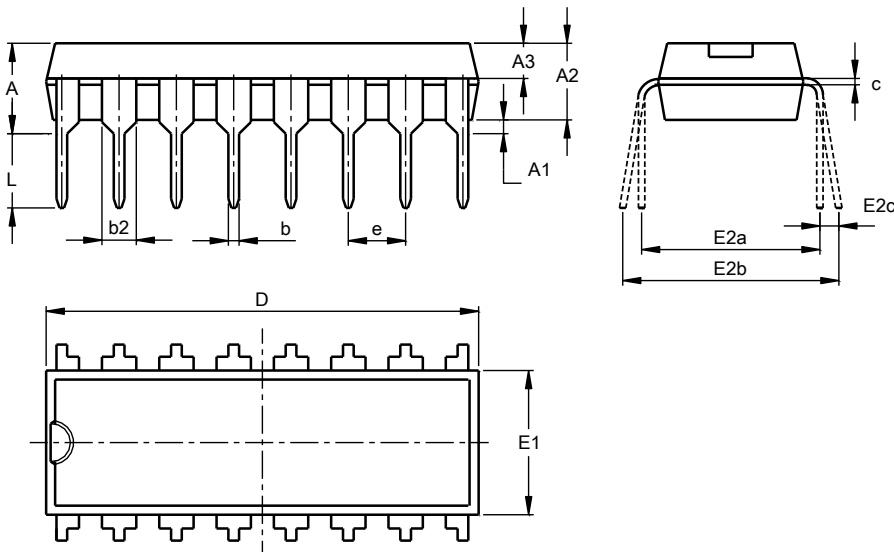
Please see <http://www.diodes.com/package-outlines.html> for the latest version.

**SO-16**



SO-16			
Dim	Min	Max	Typ
A	--	1.260	--
A1	0.10	0.23	--
A2	1.02	--	--
b	0.31	0.51	--
c	0.10	0.25	--
D	9.80	10.00	--
E	5.90	6.10	--
E1	3.80	4.00	--
e	1.27 BSC		
h	0.15	0.25	0.20
L	0.40	1.27	--
L1	1.04 REF		
L2	0.25 BSC		
R	0.07	--	--
R1	0.07	--	--
X	3.945 REF		
Y	0.661 REF		
θ	0°	8°	--
θ1	5°	15°	--
θ2	0°	--	--
All Dimensions in mm			

**PDIP-16**

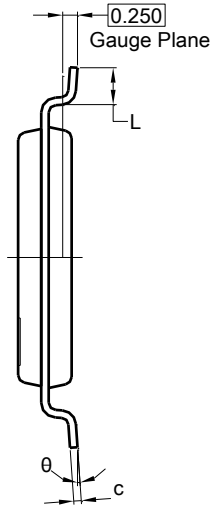
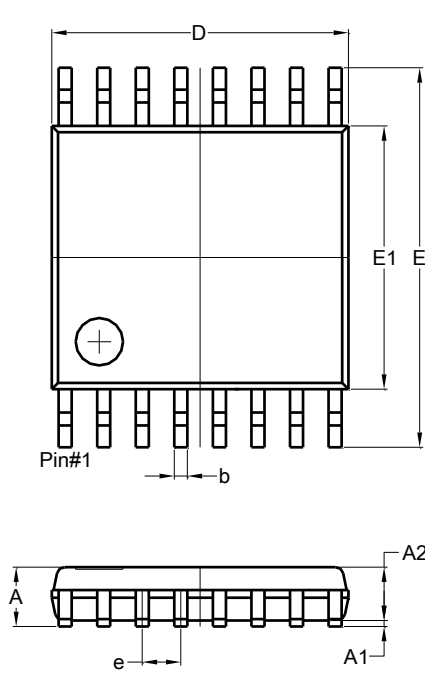


PDIP-16			
Dim	Min	Max	Nom
A	3.60	4.00	3.80
A1	0.51	-	-
A2	3.20	3.40	3.30
A3	1.47	1.57	1.52
b	0.44	0.53	-
b2	1.52BSC		
c	0.25	0.31	-
D	18.90	19.30	19.10
E1	6.15	6.55	6.35
E2a	7.62 BSC		
E2b	7.62	9.30	-
E2c	0.00	0.84	-
e	2.54BSC		
L	3.00	-	-
All Dimensions in mm			

**Package Outline Dimensions** (continued)

Please see <http://www.diodes.com/package-outlines.html> for the latest version.

**TSSOP-16 (Type CJ)**

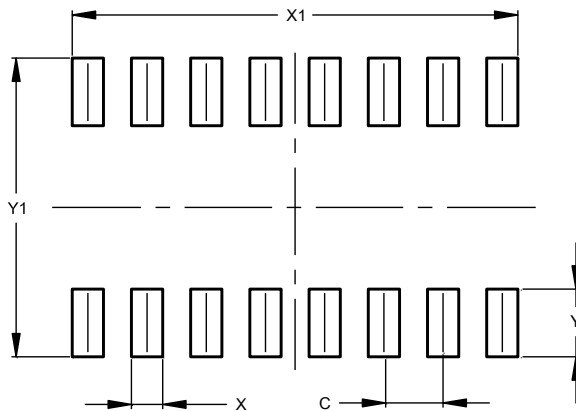


TSSOP-16 (Type CJ)			
Dim	Min	Max	Typ
A	--	1.200	--
A1	0.020	0.100	--
A2	0.800	1.000	--
b	0.190	0.300	--
c	0.090	0.200	--
D	4.900	5.100	--
E	6.250	6.550	--
E1	4.300	4.500	--
e	0.650 BSC		
L	0.500	0.700	--
θ	1°	7°	--
All Dimensions in mm			

**Suggested Pad Layout**

Please see <http://www.diodes.com/package-outlines.html> for the latest version.

**SO-16**

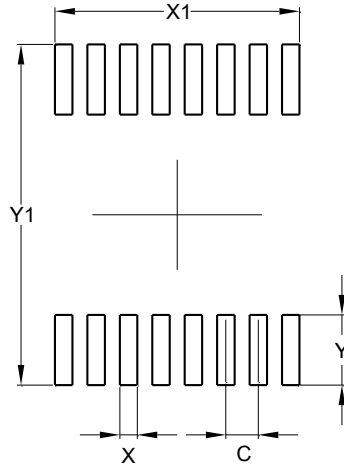


Dimensions	Value (in mm)
C	1.270
X	0.670
X1	9.560
Y	1.450
Y1	6.400

**Suggested Pad Layout** (continued)

Please see <http://www.diodes.com/package-outlines.html> for the latest version.

**TSSOP-16 (Type CJ)**



Dimensions	Value (in mm)
C	0.650
X	0.350
X1	4.900
Y	1.400
Y1	6.800

**Mechanical Data**

- Moisture Sensitivity:
  - SO-16: Level 1 per J-STD-020
  - TSSOP-16 (Type CJ): Level 1 per J-STD-020
- Terminals: Finish—Matte Tin Plated Leads, Solderable per MIL-STD-202, Method 208 **e3**
- Weight:
  - SO-16: 0.13 grams (Approximate)
  - TSSOP-16 (Type CJ): 0.055 grams (Approximate)
  - PDIP-16: 1.095 grams (Approximate)

**IMPORTANT NOTICE**

1. DIODES INCORPORATED (Diodes) AND ITS SUBSIDIARIES MAKE NO WARRANTY OF ANY KIND, EXPRESS OR IMPLIED, WITH REGARDS TO ANY INFORMATION CONTAINED IN THIS DOCUMENT, INCLUDING, BUT NOT LIMITED TO, THE IMPLIED WARRANTIES OF MERCHANTABILITY, FITNESS FOR A PARTICULAR PURPOSE OR NON-INFRINGEMENT OF THIRD PARTY INTELLECTUAL PROPERTY RIGHTS (AND THEIR EQUIVALENTS UNDER THE LAWS OF ANY JURISDICTION).
2. The Information contained herein is for informational purpose only and is provided only to illustrate the operation of Diodes' products described herein and application examples. Diodes does not assume any liability arising out of the application or use of this document or any product described herein. This document is intended for skilled and technically trained engineering customers and users who design with Diodes' products. Diodes' products may be used to facilitate safety-related applications; however, in all instances customers and users are responsible for (a) selecting the appropriate Diodes products for their applications, (b) evaluating the suitability of Diodes' products for their intended applications, (c) ensuring their applications, which incorporate Diodes' products, comply the applicable legal and regulatory requirements as well as safety and functional-safety related standards, and (d) ensuring they design with appropriate safeguards (including testing, validation, quality control techniques, redundancy, malfunction prevention, and appropriate treatment for aging degradation) to minimize the risks associated with their applications.
3. Diodes assumes no liability for any application-related information, support, assistance or feedback that may be provided by Diodes from time to time. Any customer or user of this document or products described herein will assume all risks and liabilities associated with such use, and will hold Diodes and all companies whose products are represented herein or on Diodes' websites, harmless against all damages and liabilities.
4. Products described herein may be covered by one or more United States, international or foreign patents and pending patent applications. Product names and markings noted herein may also be covered by one or more United States, international or foreign trademarks and trademark applications. Diodes does not convey any license under any of its intellectual property rights or the rights of any third parties (including third parties whose products and services may be described in this document or on Diodes' website) under this document.
5. Diodes' products are provided subject to Diodes' Standard Terms and Conditions of Sale (<https://www.diodes.com/about/company/terms-and-conditions/terms-and-conditions-of-sales/>) or other applicable terms. This document does not alter or expand the applicable warranties provided by Diodes. Diodes does not warrant or accept any liability whatsoever in respect of any products purchased through unauthorized sales channel.
6. Diodes' products and technology may not be used for or incorporated into any products or systems whose manufacture, use or sale is prohibited under any applicable laws and regulations. Should customers or users use Diodes' products in contravention of any applicable laws or regulations, or for any unintended or unauthorized application, customers and users will (a) be solely responsible for any damages, losses or penalties arising in connection therewith or as a result thereof, and (b) indemnify and hold Diodes and its representatives and agents harmless against any and all claims, damages, expenses, and attorney fees arising out of, directly or indirectly, any claim relating to any noncompliance with the applicable laws and regulations, as well as any unintended or unauthorized application.
7. While efforts have been made to ensure the information contained in this document is accurate, complete and current, it may contain technical inaccuracies, omissions and typographical errors. Diodes does not warrant that information contained in this document is error-free and Diodes is under no obligation to update or otherwise correct this information. Notwithstanding the foregoing, Diodes reserves the right to make modifications, enhancements, improvements, corrections or other changes without further notice to this document and any product described herein. This document is written in English but may be translated into multiple languages for reference. Only the English version of this document is the final and determinative format released by Diodes.
8. Any unauthorized copying, modification, distribution, transmission, display or other use of this document (or any portion hereof) is prohibited. Diodes assumes no responsibility for any losses incurred by the customers or users or any third parties arising from any such unauthorized use.
9. This Notice may be periodically updated with the most recent version available at <https://www.diodes.com/about/company/terms-and-conditions/important-notice>

The Diodes logo is a registered trademark of Diodes Incorporated in the United States and other countries.  
All other trademarks are the property of their respective owners.  
© 2024 Diodes Incorporated. All Rights Reserved.

[www.diodes.com](http://www.diodes.com)

## Looking for pricing, stock, or lifecycle information?

Click below to explore more details on WIN SOURCE:

- ⊖ [View ULN2002AS16-13 on WIN SOURCE](#)
- ⊖ [Diodes Incorporated Information](#)

## Optimize Your Supply Chain with WIN SOURCE Solutions

- ✓ Global Sourcing Solution
- ✓ Obsolete Management
- ✓ Cost Control Management
- ✓ Shortage Management
- ✓ Alternative Solution
- ✓ Excess Inventory Management