



**THE DATASHEET OF**  
**X5328S8**



X5328, X5329

CPU Supervisor with 32Kbit SPI EEPROM

FN8132  
Rev 3.00  
Nov 11, 2021

The [X5328](#) and [X5329](#) devices combine three popular functions, Power-on Reset Control, Supply Voltage Supervision, and Block Lock Protect Serial EEPROM Memory in one package. This combination lowers system cost, reduces board space requirements, and increases reliability.

Applying power to the device activates the power-on reset circuit which holds  $\overline{\text{RESET}}/\text{RESET}$  active for a period of time. This allows the power supply and oscillator to stabilize before the processor can execute code.

The device's low  $V_{CC}$  detection circuitry protects the user's system from low voltage conditions by holding  $\overline{\text{RESET}}/\text{RESET}$  active when  $V_{CC}$  falls below a minimum  $V_{CC}$  trip point.  $\overline{\text{RESET}}/\text{RESET}$  remains asserted until  $V_{CC}$  returns to proper operating level and stabilizes. Five industry standard  $V_{TRIP}$  thresholds are available, however, the unique circuits allow the threshold to be reprogrammed to meet custom requirements or to fine-tune the threshold in applications requiring higher precision.

FEATURES

- **Low  $V_{CC}$  detection and reset assertion**
  - Five standard reset threshold voltages
  - Re-program low  $V_{CC}$  reset threshold voltage using special programming sequence
  - Reset signal valid to  $V_{CC} = 1V$
- **Long battery life with low power consumption**
  - $<1\mu A$  max standby current
  - $<400\mu A$  max active current during read
- **32Kbits of EEPROM**
- **Built-in inadvertent write protection**
  - Power-up/power-down protection circuitry
  - Protect 0, 1/4, 1/2 or all of EEPROM array with Block Lock™ protection
  - In circuit programmable ROM mode
- **2MHz SPI interface modes (0,0 & 1,1)**
- **Minimize EEPROM programming time**
  - 32-byte page write mode
  - Self-timed write cycle
  - 5ms write cycle time (typical)
- **2.7V to 5.5V and 4.5V to 5.5V power supply operation**
- **Available packages**
  - 8 Ld SOIC
- **Pb-free plus anneal available (RoHS compliant)**

BLOCK DIAGRAM

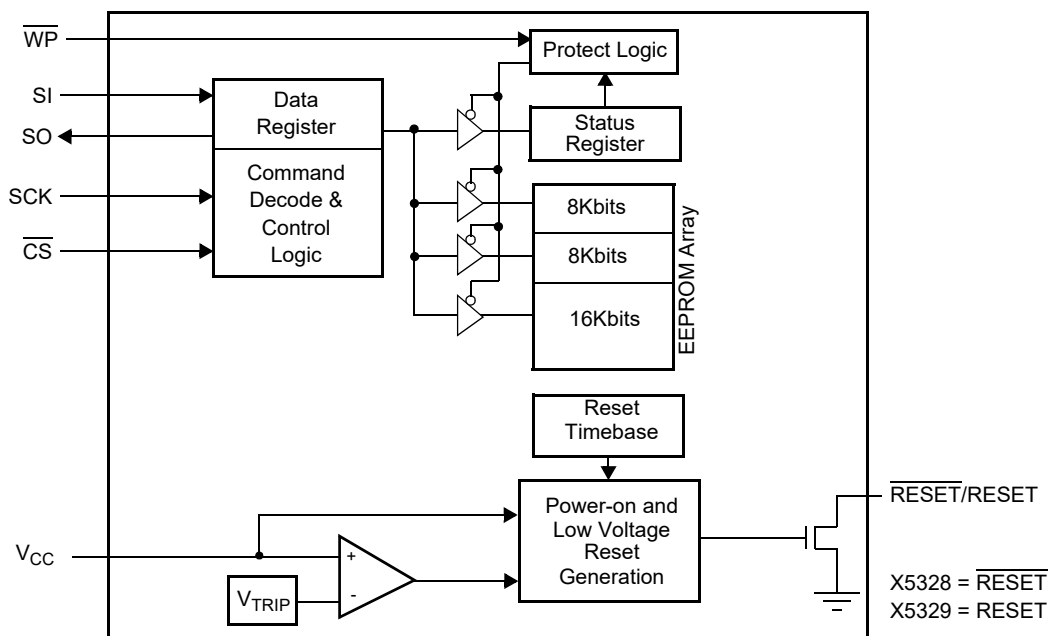

## Ordering Information

PART NUMBER (Notes 2, 3)	PART MARKING	V <sub>CC</sub> RANGE (V)	V <sub>TRIP</sub> RANGE (V)	PACKAGE DESCRIPTION (RoHS Compliant)	PKG. DWG #	Carrier Type (Note 1)	TEMP RANGE (°C)
<b>RESET ACTIVE LOW</b>							
X5328S8Z-4.5A	X5328 ZAL	4.5-5.5	4.5-4.75	8 Ld SOIC	M8.15E	Tube	0 to 70°C
X5328S8IZ-4.5A	X5328 ZAM						-40 to 85°C
X5328S8Z	X5328 Z	4.5-5.5	4.25-4.5			Tube	0 to 70°C
X5328S8ZT1							Reel, 2.5k
X5328S8IZ	X5328 ZI	4.5-5.5	4.25-4.5			Tube	-40 to 85°C
X5328S8IZT1							Reel, 2.5k
X5328S8Z-2.7A	X5328 ZAN	2.7-5.5	2.85-3.0			Tube	0 to 70°C
X5328S8IZ-2.7A	X5328 ZAP						-40 to 85°C
X5328S8Z-2.7	X5328 ZF	2.7-5.5	2.55-2.7			Tube	0 to 70°C
X5328S8Z-2.7T1							Reel, 2.5k
X5328S8IZ-2.7	X5328 ZG	2.7-5.5	2.55-2.7			Tube	-40 to 85°C
X5328S8IZ-2.7T1							Reel, 2.5k
<b>RESET ACTIVE HIGH</b>							
X5329S8Z-4.5A	X5329 ZAL	4.5-5.5	4.5-4.75	8 Ld SOIC	M8.15E	Tube	0 to 70°C
X5329S8IZ-4.5A	X5329 ZAM						-40 to 85°C
X5329S8Z	X5329 Z	4.5-5.5	4.25-4.5			Tube	0 to 70°C
X5329S8ZT1							Reel, 2.5k
X5329S8IZ	X5329 ZI	4.5-5.5	4.25-4.5			Tube	-40 to 85°C
X5329S8IZT1							Reel, 2.5k
X5329S8Z-2.7A	X5329 ZAN	2.7-5.5	2.85-3.0			Tube	0 to 70°C
X5329S8Z-2.7	X5329 ZF						2.7-5.5
X5329S8Z-2.7T1		Reel, 2.5k					
X5329S8IZ-2.7T1	X5329 ZG	2.7-5.5	2.55-2.7			Reel, 2.5k	-40 to 85°C

## NOTES:

- See [TB347](#) for details about reel specifications.
- These Pb-free plastic packaged products employ special Pb-free material sets, molding compounds/die attach materials, and 100% matte tin plate plus anneal (e3 termination finish, which is RoHS compliant and compatible with both SnPb and Pb-free soldering operations). Pb-free products are MSL classified at Pb-free peak reflow temperatures that meet or exceed the Pb-free requirements of IPC/JEDEC J-STD-020.
- For Moisture Sensitivity Level (MSL), see the [X5328](#), [X5329](#) product pages. For more information about MSL, see TB363.

## PIN DESCRIPTION

Pin Number	Name	Function
1	$\overline{CS}$	<b>Chip Select Input.</b> $\overline{CS}$ HIGH, deselects the device and the SO output pin is at a high impedance state. Unless a nonvolatile write cycle is underway, the device will be in the standby power mode. $\overline{CS}$ LOW enables the device, placing it in the active power mode. Prior to the start of any operation after power-up, a HIGH to LOW transition on $\overline{CS}$ is required.
2	SO	<b>Serial Output.</b> SO is a push/pull serial data output pin. A read cycle shifts data out on this pin. The falling edge of the serial clock (SCK) clocks the data out.
5	SI	<b>Serial Input.</b> SI is a serial data input pin. Input all opcodes, byte addresses, and memory data on this pin. The rising edge of the serial clock (SCK) latches the input data. Send all opcodes (Table 1), addresses and data MSB first.
6	SCK	<b>Serial Clock.</b> The Serial Clock controls the serial bus timing for data input and output. The rising edge of SCK latches in the opcode, address, or data bits present on the SI pin. The falling edge of SCK changes the data output on the SO pin.
3	$\overline{WP}$	<b>Write Protect.</b> The $\overline{WP}$ pin works in conjunction with a nonvolatile WPEN bit to “lock” the setting of the Watchdog Timer control and the memory write protect bits.
4	$V_{SS}$	Ground
8	$V_{CC}$	Supply Voltage
7	$\overline{RESET}/RESET$	<b>Reset Output.</b> $\overline{RESET}/RESET$ is an active LOW/HIGH, open drain output which goes active whenever $V_{CC}$ falls below the minimum $V_{CC}$ sense level. It remains active until $V_{CC}$ rises above the minimum $V_{CC}$ sense level for 200ms. $\overline{RESET}/RESET$ goes active on power-up at about 1V and remains active for 200ms after the power supply stabilizes.

## PIN CONFIGURATION

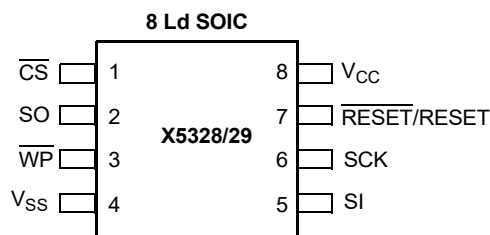

## PRINCIPLES OF OPERATION

### Power-On Reset

Application of power to the X5328/X5329 activates a Power-on Reset Circuit. This circuit goes active at about 1V and pulls the  $\overline{\text{RESET}}/\text{RESET}$  pin active. This signal prevents the system microprocessor from starting to operate with insufficient voltage or prior to stabilization of the oscillator. When  $V_{\text{CC}}$  exceeds the device  $V_{\text{TRIP}}$  value for 200ms (nominal) the circuit releases  $\overline{\text{RESET}}/\text{RESET}$ , allowing the processor to begin executing code.

### Low Voltage Monitoring

During operation, the X5328/X5329 monitors the  $V_{\text{CC}}$  level and asserts  $\overline{\text{RESET}}/\text{RESET}$  if supply voltage falls below a preset minimum  $V_{\text{TRIP}}$ . The  $\overline{\text{RESET}}/\text{RESET}$  signal prevents the microprocessor from operating in a power fail or brownout condition. The  $\overline{\text{RESET}}/\text{RESET}$  signal remains active until the voltage drops below 1V. It also remains active until  $V_{\text{CC}}$  returns and exceeds  $V_{\text{TRIP}}$  for 200ms.

### $V_{\text{CC}}$ Threshold Reset Procedure

The X5328/X5329 has a standard  $V_{\text{CC}}$  threshold ( $V_{\text{TRIP}}$ ) voltage. This value will not change over normal operating and storage conditions. However, in applications where the standard  $V_{\text{TRIP}}$  is not exactly right, or for higher precision in the  $V_{\text{TRIP}}$  value, the X5328/X5329 threshold may be adjusted.

### Setting the $V_{\text{TRIP}}$ Voltage

This procedure sets the  $V_{\text{TRIP}}$  to a higher voltage value. For example, if the current  $V_{\text{TRIP}}$  is 4.4V and the new  $V_{\text{TRIP}}$  is 4.6V, this procedure directly makes the change. If the new setting is lower than the current setting, then it is necessary to reset the trip point before setting the new value.

To set the new  $V_{\text{TRIP}}$  voltage, apply the desired  $V_{\text{TRIP}}$  threshold to the  $V_{\text{CC}}$  pin and tie the  $\overline{\text{CS}}$  pin and the  $\overline{\text{WP}}$  pin HIGH.  $\overline{\text{RESET}}/\text{RESET}$  and SO pins are left unconnected. Then apply the programming voltage  $V_{\text{P}}$  to both SCK and SI and pulse  $\overline{\text{CS}}$  LOW then HIGH. Remove  $V_{\text{P}}$  and the sequence is complete.

Figure 1. Set  $V_{\text{TRIP}}$  Voltage

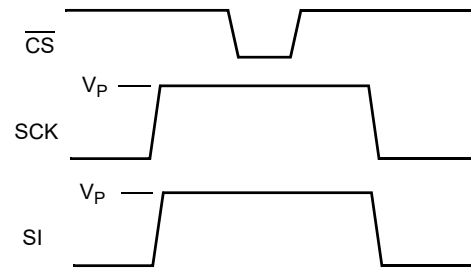

### Resetting the $V_{\text{TRIP}}$ Voltage

This procedure sets the  $V_{\text{TRIP}}$  to a “native” voltage level. For example, if the current  $V_{\text{TRIP}}$  is 4.4V and the  $V_{\text{TRIP}}$  is reset, the new  $V_{\text{TRIP}}$  is something less than 1.7V. This procedure must be used to set the voltage to a lower value.

To reset the  $V_{\text{TRIP}}$  voltage, apply a voltage between 2.7 and 5.5V to the  $V_{\text{CC}}$  pin. Tie the  $\overline{\text{CS}}$  pin, the  $\overline{\text{WP}}$  pin, and the SCK pin HIGH.  $\overline{\text{RESET}}/\text{RESET}$  and SO pins are left unconnected. Then apply the programming voltage  $V_{\text{P}}$  to the SI pin ONLY and pulse  $\overline{\text{CS}}$  LOW then HIGH. Remove  $V_{\text{P}}$  and the sequence is complete.

Figure 2. Reset  $V_{\text{TRIP}}$  Voltage

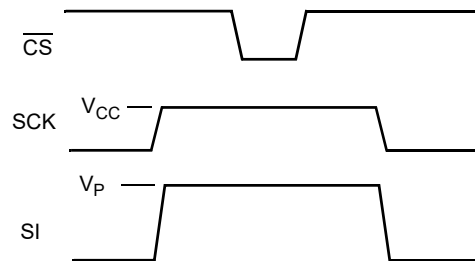

Figure 3.  $V_{TRIP}$  Programming Sequence Flow Chart

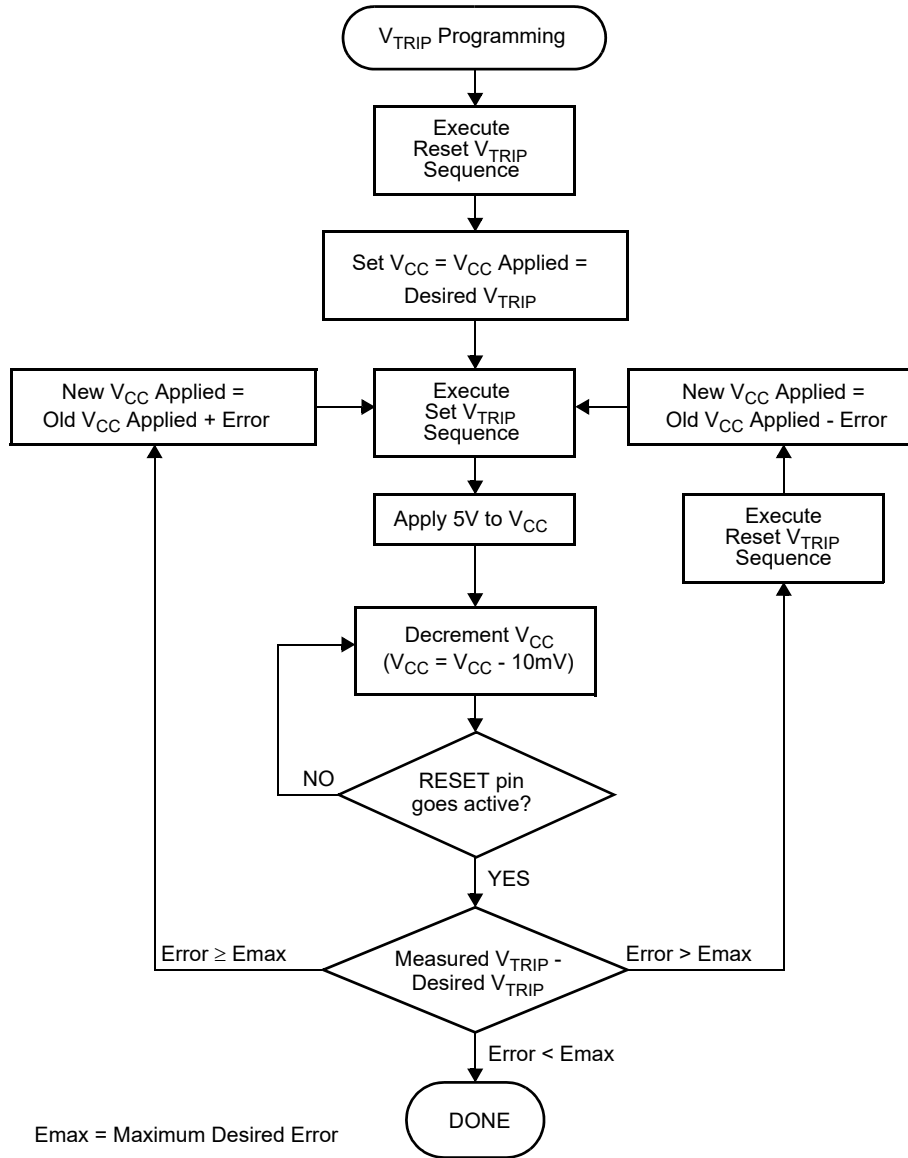
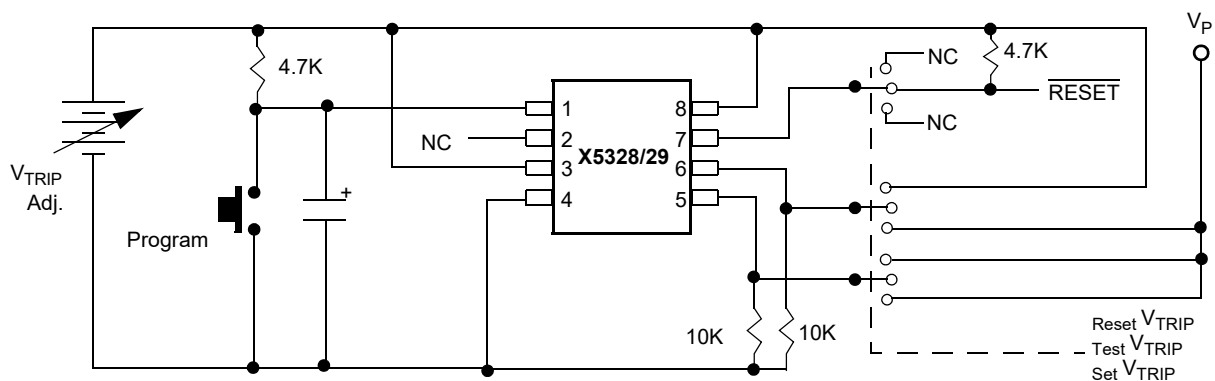

Figure 4. Sample  $V_{TRIP}$  Reset Circuit



## SPI SERIAL MEMORY

The memory portion of the device is a CMOS Serial EEPROM array with block lock protection. The array is internally organized as x 8. The device features a Serial Peripheral Interface (SPI) and software protocol allowing operation on a simple four-wire bus.

The device utilizes proprietary Direct Write™ cell, providing a minimum endurance of 100,000 cycles and a minimum data retention of 100 years.

The device is designed to interface directly with the synchronous Serial Peripheral Interface (SPI) of many popular microcontroller families. It contains an 8-bit instruction register that is accessed via the SI input, with data being clocked in on the rising edge of SCK.  $\overline{CS}$  must be LOW during the entire operation.

All instructions (Table 1), addresses and data are transferred MSB first. Data input on the SI line is latched on the first rising edge of SCK after  $\overline{CS}$  goes LOW. Data is output on the SO line by the falling edge of SCK. SCK is static, allowing the user to stop the clock and then start it again to resume operations where left off.

## Write Enable Latch

The device contains a Write Enable Latch. This latch must be SET before a Write Operation is initiated. The WREN instruction will set the latch and the WRDI instruction will reset the latch (Figure 3). This latch is automatically reset upon a power-up condition and after the completion of a valid Write Cycle.

## Status Register

The RDSR instruction provides access to the Status Register. The Status Register may be read at any time, even during a Write Cycle. The Status Register is formatted as follows:

7	6	5	4	3	2	1	0
WPEN	FLB	1*	1*	BL1	BL0	WEL	WIP

\*Bits (5,4) should be written as '1' only.

The Write-In-Progress (WIP) bit is a volatile, read only bit and indicates whether the device is busy with an internal nonvolatile write operation. The WIP bit is read using the RDSR instruction. When set to a "1", a nonvolatile write operation is in progress. When set to a "0", no write is in progress.

**Table 1. Instruction Set**

Instruction Name	Instruction Format*	Operation
WREN	0000 0110	Set the Write Enable Latch (Enable Write Operations)
SFLB	0000 0000	Set Flag Bit
WRDI/RFLB	0000 0100	Reset the Write Enable Latch/Reset Flag Bit
RSDR	0000 0101	Read Status Register
WRSR	0000 0001	Write Status Register (Block Lock, WPEN & Flag Bits)
READ	0000 0011	Read Data from Memory Array Beginning at Selected Address
WRITE	0000 0010	Write Data to Memory Array Beginning at Selected Address

Note: \*Instructions are shown MSB in leftmost position. Instructions are transferred MSB first.

**Table 2. Block Protect Matrix**

WREN CMD	Status Register	Device Pin	Block	Block	Status Register
WEL	WPEN	WP#	Protected Block	Unprotected Block	WPEN, BL0, BL1, WD0, WD1
0	X	X	Protected	Protected	Protected
1	1	0	Protected	Writable	Protected
1	0	X	Protected	Writable	Writable
1	X	1	Protected	Writable	Writable

The Write Enable Latch (WEL) bit indicates the Status of the Write Enable Latch. When WEL = 1, the latch is set HIGH and when WEL = 0 the latch is reset LOW. The

WEL bit is a volatile, read only bit. It can be set by the WREN instruction and can be reset by the WRDS instruction.

The block lock bits, BL0 and BL1, set the level of block lock protection. These nonvolatile bits are programmed using the WRSR instruction and allow the user to protect one quarter, one half, all or none of the EEPROM array. Any portion of the array that is block lock protected can be read but not written. It will remain protected until the BL bits are altered to disable block lock protection of that portion of memory.

Status Register Bits		Array Addresses Protected
BL1	BL0	X5328/X5329
0	0	None
0	1	\$0C00-\$0FFF
1	0	\$0800-\$0FFF
1	1	\$0000-\$0FFF

The FLAG bit shows the status of a volatile latch that can be set and reset by the system using the SFLB and RFLB instructions. The Flag bit is automatically reset upon power-up.

The nonvolatile WPEN bit is programmed using the WRSR instruction. This bit works in conjunction with the  $\overline{WP}$  pin to provide an In-Circuit Programmable ROM function (Table 2).  $\overline{WP}$  is LOW and WPEN bit programmed HIGH disables all Status Register Write Operations.

### In Circuit Programmable ROM Mode

This mechanism protects the block lock and Watchdog bits from inadvertent corruption.

In the locked state (Programmable ROM Mode) the  $\overline{WP}$  pin is LOW and the nonvolatile bit WPEN is “1”. This mode disables nonvolatile writes to the device’s Status Register.

Setting the  $\overline{WP}$  pin LOW while WPEN is a “1” while an internal write cycle to the Status Register is in progress will not stop this write operation, but the operation disables subsequent write attempts to the Status Register.

When  $\overline{WP}$  is HIGH, all functions, including nonvolatile writes to the Status Register operate normally.

Setting the WPEN bit in the Status Register to “0” blocks the  $\overline{WP}$  pin function, allowing writes to the Status Register when  $\overline{WP}$  is HIGH or LOW. Setting the WPEN bit to “1” while the  $\overline{WP}$  pin is LOW activates the Programmable ROM mode, thus requiring a change in the  $\overline{WP}$  pin prior to subsequent Status Register changes. This allows manufacturing to install the device in a system with  $\overline{WP}$  pin grounded and still be able to program the Status Register. Manufacturing can then load Configuration data, manufacturing time and other parameters into the EEPROM, then set the portion of memory to be protected by setting the block lock bits, and finally set the “OTP mode” by setting the WPEN bit. Data changes now require a hardware change.

Figure 5. Read EEPROM Array Sequence

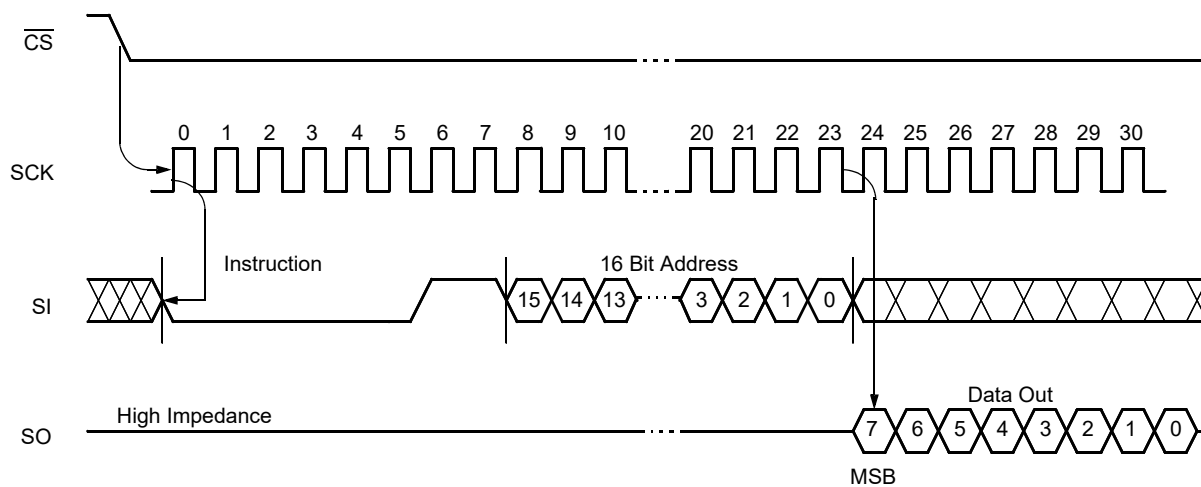

## Read Sequence

When reading from the EEPROM memory array,  $\overline{CS}$  is first pulled low to select the device. The 8-bit READ instruction is transmitted to the device, followed by the 16-bit address. After the READ opcode and address are sent, the data stored in the memory at the selected address is shifted out on the SO line. The data stored in memory at the next address can be read sequentially by continuing to provide clock pulses. The address is automatically incremented to the next higher address after each byte of data is shifted out. When the highest address is reached, the address counter rolls over to address \$0000 allowing the read cycle to be continued indefinitely. The read operation is terminated by taking  $\overline{CS}$  high. Refer to the Read EEPROM Array Sequence (Figure 1).

To read the Status Register, the  $\overline{CS}$  line is first pulled low to select the device followed by the 8-bit RDSR instruction. After the RDSR opcode is sent, the contents of the Status Register are shifted out on the SO line. Refer to the Read Status Register Sequence (Figure 2).

## Write Sequence

Prior to any attempt to write data into the device, the "Write Enable" Latch (WEL) must first be set by issuing the WREN instruction (Figure 3).  $\overline{CS}$  is first taken LOW, then the WREN instruction is clocked into the device. After all eight bits of the instruction are transmitted,  $\overline{CS}$  must then be taken HIGH. If the user continues the Write Operation without taking  $\overline{CS}$  HIGH after issuing the WREN instruction, the Write Operation will be ignored.

To write data to the EEPROM memory array, the user then issues the WRITE instruction followed by the 16-bit address and then the data to be written. Any unused address bits are specified to be "0's". The WRITE operation minimally takes 32 clocks.  $\overline{CS}$  must go low and remain low for the duration of the operation. If the address counter reaches the end of a page and the clock continues, the counter will roll back to the first address of the page and overwrite any data that may have been previously written.

For the Page Write Operation (byte or page write) to be completed,  $\overline{CS}$  can only be brought HIGH after bit 0 of the last data byte to be written is clocked in. If it is brought HIGH at any other time, the write operation will not be completed (Figure 4).

To write to the Status Register, the WRSR instruction is followed by the data to be written (Figure 5). Data bits 0 and 1 must be "0".

While the write is in progress following a Status Register or EEPROM Sequence, the Status Register may be read to check the WIP bit. During this time the WIP bit will be high.

## OPERATIONAL NOTES

The device powers-up in the following state:

- The device is in the low power standby state.
- A HIGH to LOW transition on  $\overline{CS}$  is required to enter an active state and receive an instruction.
- SO pin is high impedance.
- The Write Enable Latch is reset.
- The Flag Bit is reset.
- Reset Signal is active for  $t_{PURST}$ .

## Data Protection

The following circuitry has been included to prevent inadvertent writes:

- A WREN instruction must be issued to set the Write Enable Latch.
- $\overline{CS}$  must come HIGH at the proper clock count in order to start a nonvolatile write cycle.

**Figure 6. Read Status Register Sequence**

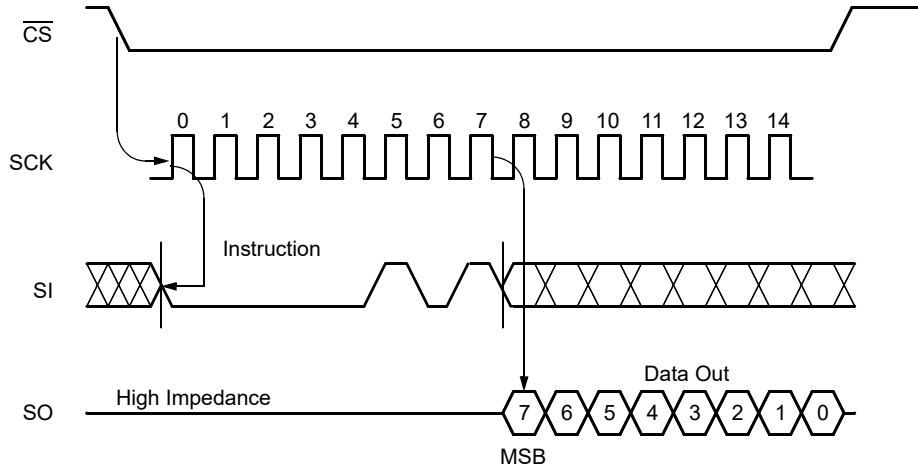

**Figure 7. Write Enable Latch Sequence**

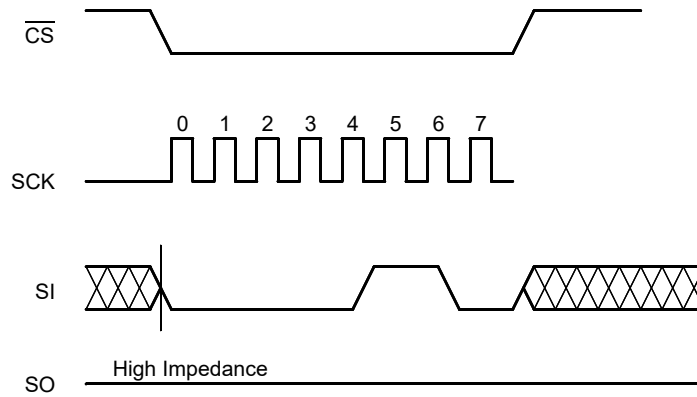

**Figure 8. Write Sequence**

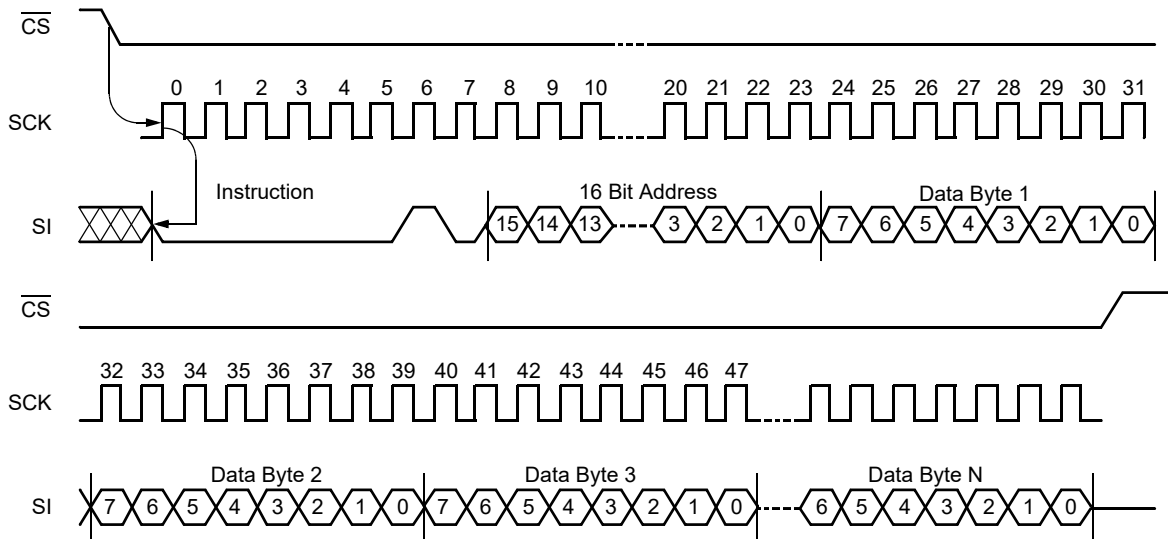

**Figure 9. Status Register Write Sequence**

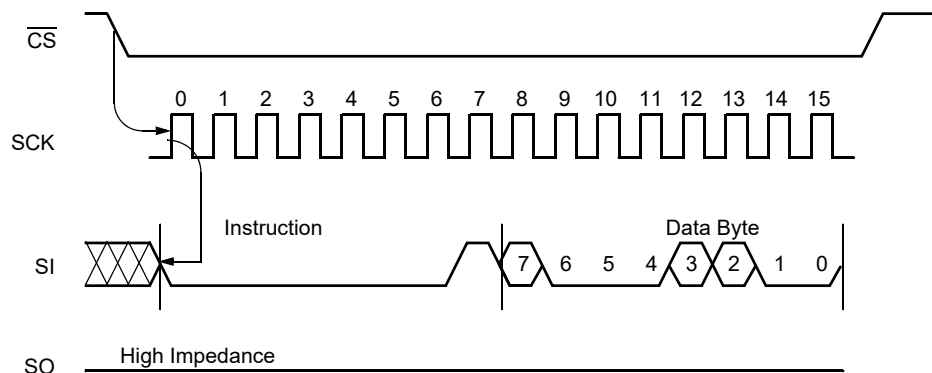

**SYMBOL TABLE**

WAVEFORM	INPUTS	OUTPUTS
	Must be steady	Will be steady
	May change from LOW to HIGH	Will change from LOW to HIGH
	May change from HIGH to LOW	Will change from HIGH to LOW
	Don't Care: Changes Allowed	Changing: State Not Known
	N/A	Center Line is High Impedance

**ABSOLUTE MAXIMUM RATINGS**

Temperature under bias .....	-65°C to +135°C
Storage temperature .....	-65°C to +150°C
Voltage on any pin with respect to $V_{SS}$ .....	-1.0V to +7V
D.C. output current .....	5mA
Lead temperature (soldering, 10s) .....	300°C

**COMMENT**

Stresses above those listed under “Absolute Maximum Ratings” may cause permanent damage to the device. This is a stress rating only; functional operation of the device (at these or any other conditions above those listed in the operational sections of this specification) is not implied. Exposure to absolute maximum rating conditions for extended periods may affect device reliability.

**RECOMMENDED OPERATING CONDITIONS**

Temperature	Min.	Max.
Commercial	0°C	70°C
Industrial	-40°C	+85°C

Voltage Option	Supply Voltage
-2.7 or -2.7A	2.7V to 5.5V
Blank or -4.5A	4.5V-5.5V

**D.C. OPERATING CHARACTERISTICS** (Over the recommended operating conditions unless otherwise specified.)

Symbol	Parameter	Limits			Unit	Test Conditions
		Min.	Typ.	Max.		
$I_{CC1}$	$V_{CC}$ Write Current (Active)			5	mA	SCK = $V_{CC} \times 0.1/V_{CC} \times 0.9$ @ 2MHz, SO = Open
$I_{CC2}$	$V_{CC}$ Read Current (Active)			0.4	mA	SCK = $V_{CC} \times 0.1/V_{CC} \times 0.9$ @ 2MHz, SO = Open
$I_{SB}$	$V_{CC}$ Standby Current			1	$\mu$ A	$\overline{CS} = V_{CC}$ ; $V_{IN} = V_{SS}$ or $V_{CC}$ , $V_{CC} = 5.5V$
$I_{LI}$	Input Leakage Current		0.1	10	$\mu$ A	$V_{IN} = V_{SS}$ to $V_{CC}$
$I_{LO}$	Output Leakage Current		0.1	10	$\mu$ A	$V_{OUT} = V_{SS}$ to $V_{CC}$
$V_{IL}^{(1)}$	Input LOW Voltage	-0.5		$V_{CC} \times 0.3$	V	
$V_{IH}^{(1)}$	Input HIGH Voltage	$V_{CC} \times 0.7$		$V_{CC} + 0.5$	V	
$V_{OL1}$	Output LOW Voltage			0.4	V	$V_{CC} > 3.3V$ , $I_{OL} = 2.1mA$
$V_{OL2}$	Output LOW Voltage			0.4	V	$2V < V_{CC} \leq 3.3V$ , $I_{OL} = 1mA$
$V_{OL3}$	Output LOW Voltage			0.4	V	$V_{CC} \leq 2V$ , $I_{OL} = 0.5mA$
$V_{OH1}$	Output HIGH Voltage	$V_{CC} - 0.8$			V	$V_{CC} > 3.3V$ , $I_{OH} = -1.0mA$
$V_{OH2}$	Output HIGH Voltage	$V_{CC} - 0.4$			V	$2V < V_{CC} \leq 3.3V$ , $I_{OH} = -0.4mA$
$V_{OH3}$	Output HIGH Voltage	$V_{CC} - 0.2$			V	$V_{CC} \leq 2V$ , $I_{OH} = -0.25mA$
$V_{OLS}$	Reset Output LOW Voltage			0.4	V	$I_{OL} = 1mA$

**CAPACITANCE**  $T_A = +25^\circ C$ ,  $f = 1MHz$ ,  $V_{CC} = 5V$ 

Symbol	Test	Max.	Unit	Conditions
$C_{OUT}^{(2)}$	Output Capacitance (SO, RESET, RESET)	8	pF	$V_{OUT} = 0V$
$C_{IN}^{(2)}$	Input Capacitance (SCK, SI, $\overline{CS}$ , $\overline{WP}$ )	6	pF	$V_{IN} = 0V$

Notes: (1)  $V_{IL}$  min. and  $V_{IH}$  max. are for reference only and are not tested.  
(2) This parameter is periodically sampled and not 100% tested.

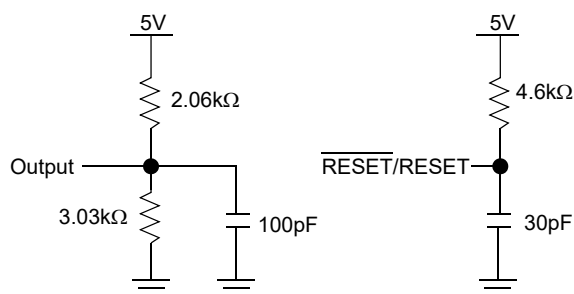
**EQUIVALENT A.C. LOAD CIRCUIT AT 5V  $V_{CC}$** **A.C. TEST CONDITIONS**

Input pulse levels	$V_{CC} \times 0.1$ to $V_{CC} \times 0.9$
Input rise and fall times	10ns
Input and output timing level	$V_{CC} \times 0.5$

**A.C. CHARACTERISTICS** (Over recommended operating conditions, unless otherwise specified)**Serial Input Timing**

Symbol	Parameter	2.7-5.5V		Unit
		Min.	Max.	
$f_{SCK}$	Clock Frequency	0	2	MHz
$t_{CYC}$	Cycle Time	500		ns
$t_{LEAD}$	$\overline{CS}$ Lead Time	250		ns
$t_{LAG}$	$\overline{CS}$ Lag Time	250		ns
$t_{WH}$	Clock HIGH Time	200		ns
$t_{WL}$	Clock LOW Time	250		ns
$t_{SU}$	Data Setup Time	50		ns
$t_H$	Data Hold Time	50		ns
$t_{RI}^{(3)}$	Input Rise Time		100	ns
$t_{FI}^{(3)}$	Input Fall Time		100	ns
$t_{CS}$	$\overline{CS}$ Deselect Time	500		ns
$t_{WC}^{(4)}$	Write Cycle Time		10	ms

### Serial Input Timing

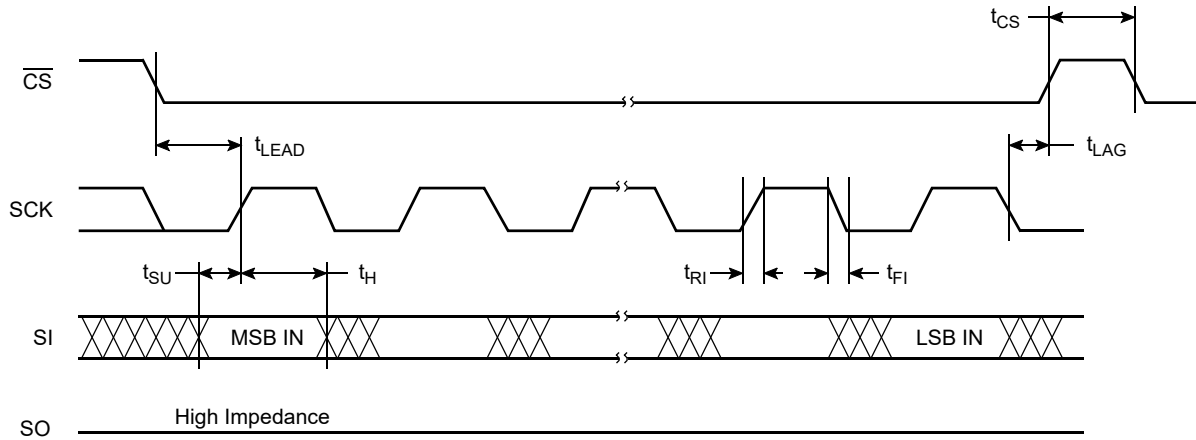

### Serial Output Timing

Symbol	Parameter	2.7-5.5V		Unit
		Min.	Max.	
$f_{SCK}$	Clock Frequency	0	2	MHz
$t_{DIS}$	Output Disable Time		250	ns
$t_V$	Output Valid from Clock Low		250	ns
$t_{HO}$	Output Hold Time	0		ns
$t_{RO}^{(3)}$	Output Rise Time		100	ns
$t_{FO}^{(3)}$	Output Fall Time		100	ns

Notes: (3) This parameter is periodically sampled and not 100% tested.  
 (4)  $t_{WC}$  is the time from the rising edge of CS after a valid write sequence has been sent to the end of the self-timed internal nonvolatile write cycle.

### Serial Output Timing

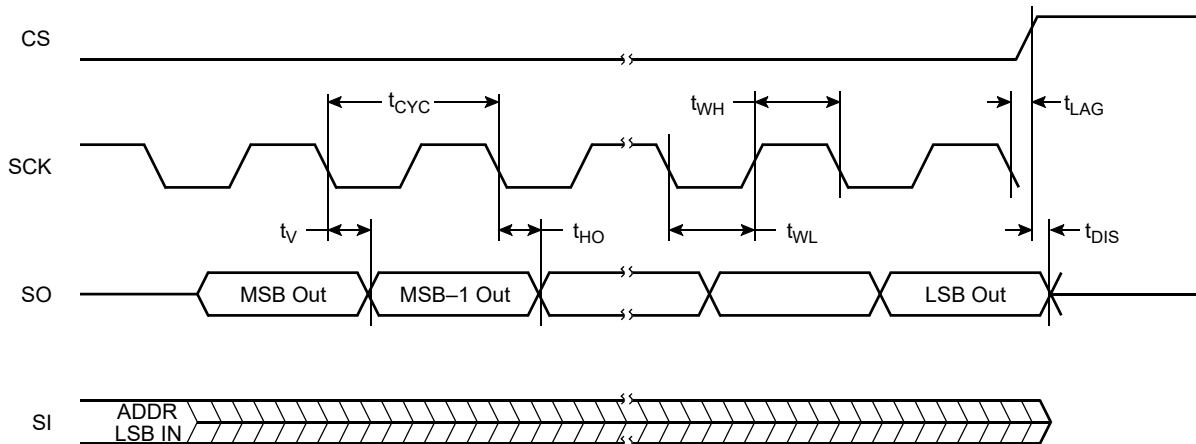

## Power-Up and Power-Down Timing

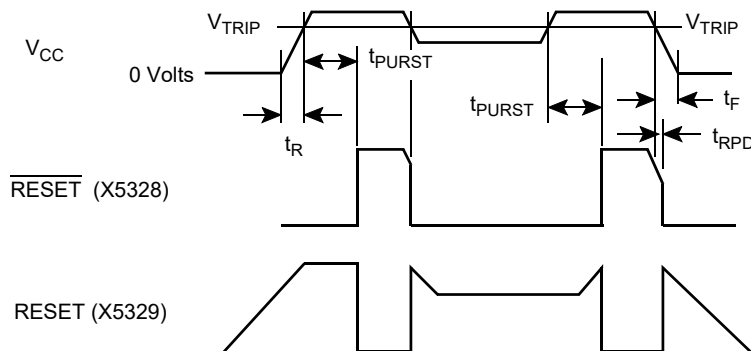

## RESET Output Timing

Symbol	Parameter	Min.	Typ.	Max.	Unit
$V_{TRIP}$	Reset Trip Point Voltage, X5328-4.5A, X5328-4.5A	4.5	4.63	4.75	V
	Reset Trip Point Voltage, X5328, X5329	4.25	4.38	4.5	
	Reset Trip Point Voltage, X5328-2.7A, X5329-2.7A	2.85	2.93	3.0	
	Reset Trip Point Voltage, X5328-2.7, X5329-2.7	2.55	2.63	2.7	
$V_{TH}$	$V_{TRIP}$ Hysteresis (HIGH to LOW vs. LOW to HIGH $V_{TRIP}$ voltage)		20		mV
$t_{PURST}$	Power-up Reset Time Out	100	200	280	ms
$t_{RPD}^{(5)}$	$V_{CC}$ Detect to Reset/Output			500	ns
$t_F^{(5)}$	$V_{CC}$ Fall Time	100			$\mu$ s
$t_R^{(5)}$	$V_{CC}$ Rise Time	100			$\mu$ s
$V_{RVALID}$	Reset Valid $V_{CC}$	1			V

Note: (5) This parameter is periodically sampled and not 100% tested.

**V<sub>TRIP</sub> Set Conditions**

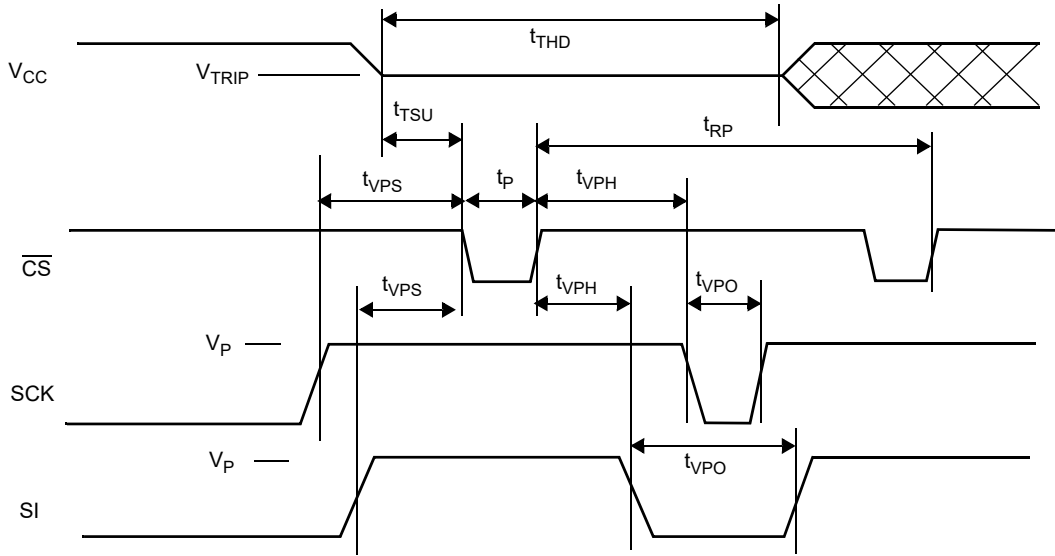

**V<sub>TRIP</sub> Reset Conditions**

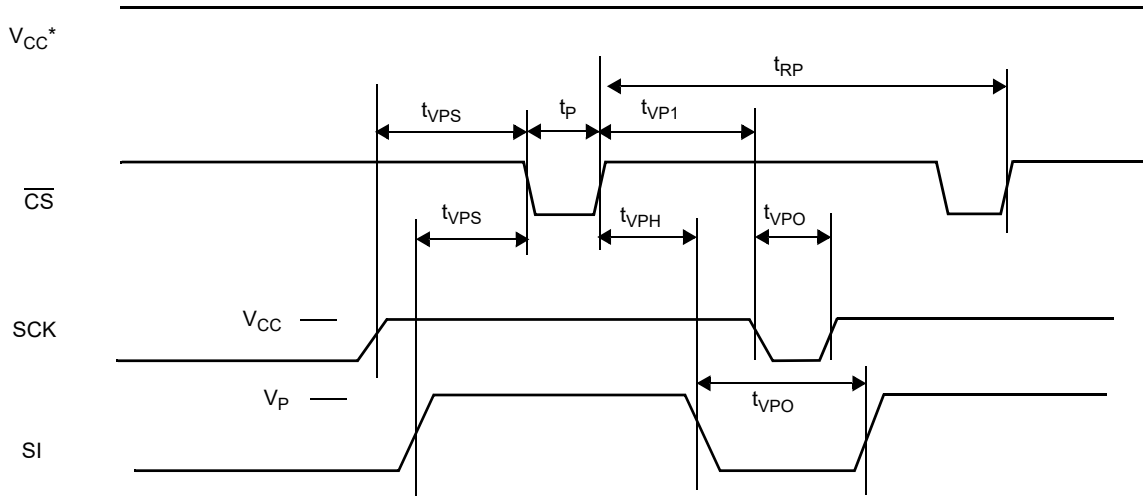

\*V<sub>CC</sub> > Programmed V<sub>TRIP</sub>

**V<sub>TRIP</sub> Programming Specifications** V<sub>CC</sub> = 1.7-5.5V; Temperature = 0°C to 70°C

Parameter	Description	Min.	Max.	Unit
t <sub>VPS</sub>	SCK V <sub>TRIP</sub> Program Voltage Setup time	1		μs
t <sub>VPH</sub>	SCK V <sub>TRIP</sub> Program Voltage Hold time	1		μs
t <sub>P</sub>	V <sub>TRIP</sub> Program Pulse Width	1		μs
t <sub>TSU</sub>	V <sub>TRIP</sub> Level Setup time	10		μs
t <sub>THD</sub>	V <sub>TRIP</sub> Level Hold (stable) time	10		ms
t <sub>WC</sub>	V <sub>TRIP</sub> Write Cycle Time		10	ms
t <sub>RP</sub>	V <sub>TRIP</sub> Program Cycle Recovery Period (Between successive programming cycles)	10		ms
t <sub>VPO</sub>	SCK V <sub>TRIP</sub> Program Voltage Off time before next cycle	0		ms
V <sub>P</sub>	Programming Voltage	15	18	V
V <sub>TRAN</sub>	V <sub>TRIP</sub> Programmed Voltage Range	1.7	5.0	V
V <sub>ta1</sub>	Initial V <sub>TRIP</sub> Program Voltage accuracy (V <sub>CC</sub> applied-V <sub>TRIP</sub> ) (Programmed at 25°C.)	-0.1	+0.4	V
V <sub>ta2</sub>	Subsequent V <sub>TRIP</sub> Program Voltage accuracy [(V <sub>CC</sub> applied-V <sub>ta1</sub> )-V <sub>TRIP</sub> ] (Programmed at 25°C.)	-25	+25	mV
V <sub>tr</sub>	V <sub>TRIP</sub> Program Voltage repeatability (Successive program operations.) (programmed at 25°C)	-25	+25	mV
V <sub>tv</sub>	V <sub>TRIP</sub> Program variation after programming (0-75°C). (programmed at 25°C)	-25	+25	mV

V<sub>TRIP</sub> programming parameters are periodically sampled and are not 100% tested.

**TYPICAL PERFORMANCE**

**V<sub>CC</sub> Supply Current vs. Temperature (I<sub>SB</sub>)**

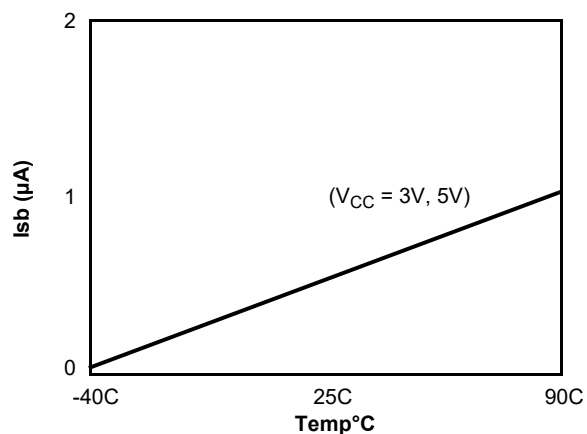

**t<sub>PURST</sub> vs. Temperature**

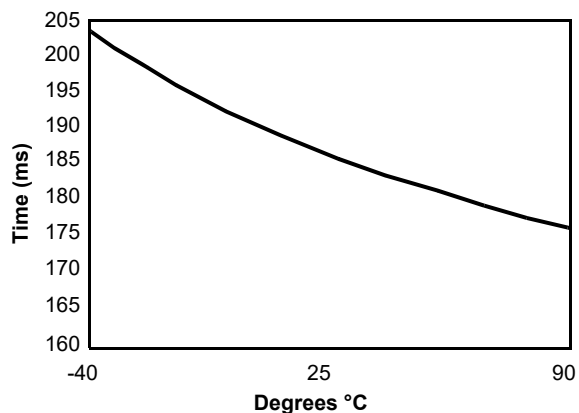

**V<sub>TRIP</sub> vs. Temperature (programmed at 25°C)**

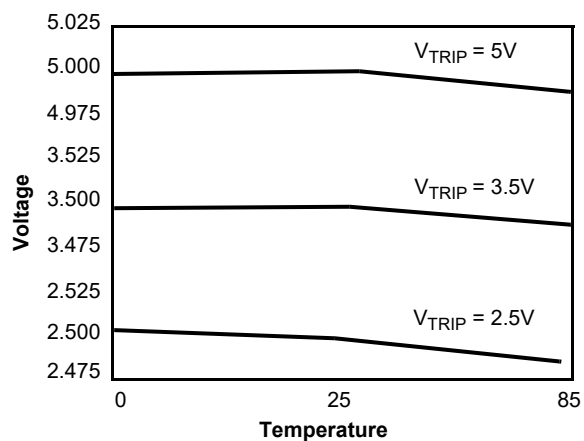

**Revision History**

The revision history provided is for informational purposes only and is believed to be accurate, but not warranted. Please go to the web to make sure that you have the latest revision.

DATE	REVISION	CHANGE
Nov 11, 2021	3.00	Removed About Intersil section. Removed TSSOP and PDIP information from document. Updated Pin Configuration. Updated Ordering information table formatting.
Oct16, 2015	2.00	Updated the Ordering Information table on page 2. Added Revision History and About Intersil sections. Replaced all Package Outline drawings with the most recent versions.

# Package Outline Drawing

For the most recent package outline drawing, see [M8.15E](#).

M8.15E

8 Lead Narrow Body Small Outline Plastic Package

Rev 0, 08/09

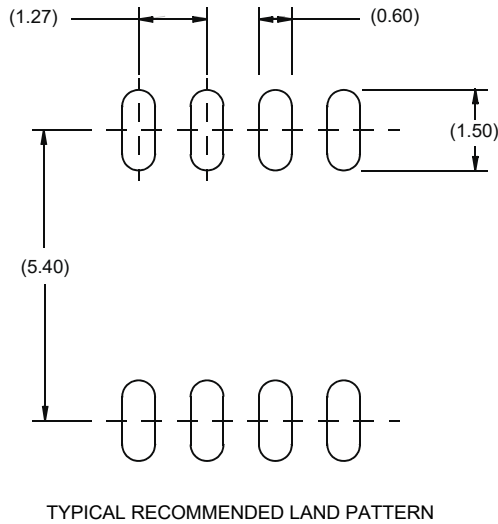
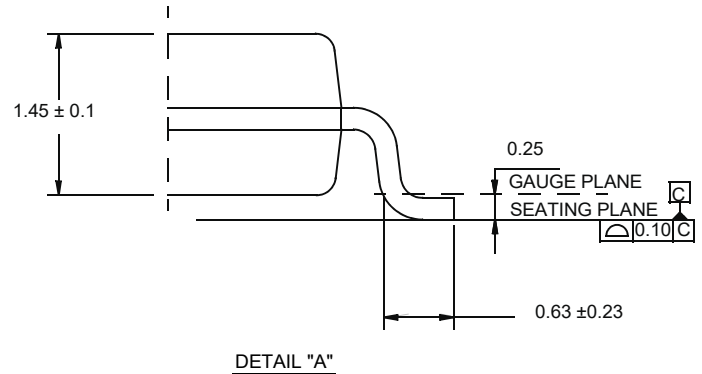
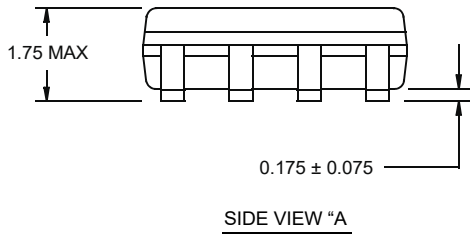
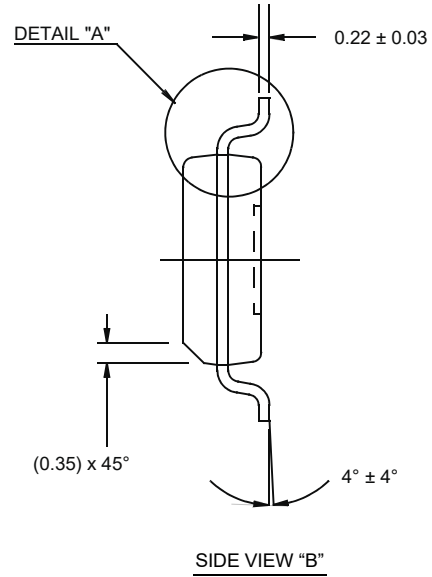
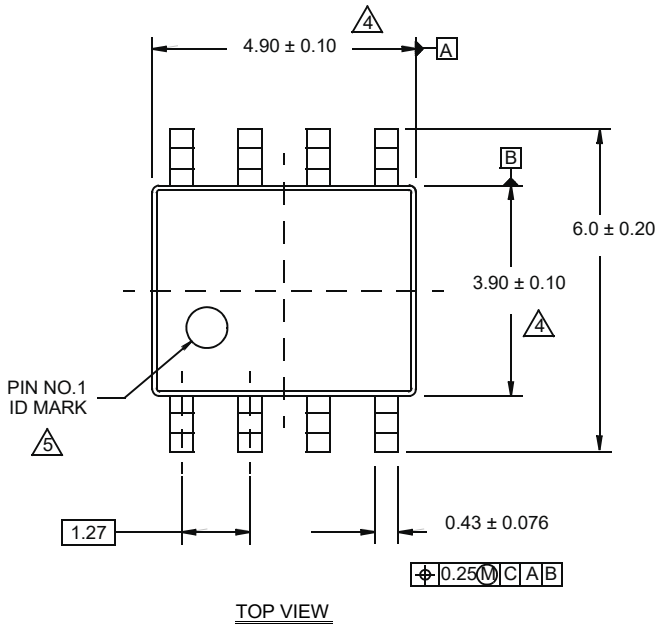

**NOTES:**

1. Dimensions are in millimeters.  
Dimensions in ( ) for Reference Only.
2. Dimensioning and tolerancing conform to AMSE Y14.5m-1994.
3. Unless otherwise specified, tolerance : Decimal ± 0.05
4. Dimension does not include interlead flash or protrusions.  
Interlead flash or protrusions shall not exceed 0.25mm per side.
5. The pin #1 identifier may be either a mold or mark feature.
6. Reference to JEDEC MS-012.

## IMPORTANT NOTICE AND DISCLAIMER

RENESAS ELECTRONICS CORPORATION AND ITS SUBSIDIARIES (“RENESAS”) PROVIDES TECHNICAL SPECIFICATIONS AND RELIABILITY DATA (INCLUDING DATASHEETS), DESIGN RESOURCES (INCLUDING REFERENCE DESIGNS), APPLICATION OR OTHER DESIGN ADVICE, WEB TOOLS, SAFETY INFORMATION, AND OTHER RESOURCES “AS IS” AND WITH ALL FAULTS, AND DISCLAIMS ALL WARRANTIES, EXPRESS OR IMPLIED, INCLUDING, WITHOUT LIMITATION, ANY IMPLIED WARRANTIES OF MERCHANTABILITY, FITNESS FOR A PARTICULAR PURPOSE, OR NON-INFRINGEMENT OF THIRD PARTY INTELLECTUAL PROPERTY RIGHTS.

These resources are intended for developers skilled in the art designing with Renesas products. You are solely responsible for (1) selecting the appropriate products for your application, (2) designing, validating, and testing your application, and (3) ensuring your application meets applicable standards, and any other safety, security, or other requirements. These resources are subject to change without notice. Renesas grants you permission to use these resources only for development of an application that uses Renesas products. Other reproduction or use of these resources is strictly prohibited. No license is granted to any other Renesas intellectual property or to any third party intellectual property. Renesas disclaims responsibility for, and you will fully indemnify Renesas and its representatives against, any claims, damages, costs, losses, or liabilities arising out of your use of these resources. Renesas' products are provided only subject to Renesas' Terms and Conditions of Sale or other applicable terms agreed to in writing. No use of any Renesas resources expands or otherwise alters any applicable warranties or warranty disclaimers for these products.

(Rev.1.0 Mar 2020)

### Corporate Headquarters

TOYOSU FORESIA, 3-2-24 Toyosu,  
Koto-ku, Tokyo 135-0061, Japan  
[www.renesas.com](http://www.renesas.com)

### Contact Information



For further information on a product, technology, the most up-to-date version of a document, or your nearest sales office, please visit:  
[www.renesas.com/contact/](http://www.renesas.com/contact/)

### Trademarks

Renesas and the Renesas logo are trademarks of Renesas Electronics Corporation. All trademarks and registered trademarks are the property of their respective owners.

## Looking for pricing, stock, or lifecycle information?

Click below to explore more details on WIN SOURCE:

-  [View X5328S8 on WIN SOURCE](#)
-  [Renesas Electronics America](#) Information

## Optimize Your Supply Chain with WIN SOURCE Solutions

-  Global Sourcing Solution
-  Obsolete Management
-  Cost Control Management
-  Shortage Management
-  Alternative Solution
-  Excess Inventory Management