



THE DATASHEET OF ZL6105ALAFT



ZL6105

Digital DC/DC Controller with Drivers and Auto Compensation

FN6906
Rev 6.0
Jun 22, 2021

The **ZL6105** is a digital power controller with integrated MOSFET drivers. Auto compensation eliminates the need for manual compensation design work. Adaptive performance optimization algorithms improve power conversion efficiency. Zilker Labs Digital-DC™ technology enables a blend of power conversion performance and power management features.

The ZL6105 is designed to be a flexible building block for DC power and can be easily adapted to designs ranging from a single-phase power supply operating from a 3.3V to a multiphase current sharing supply operating from a 12V input. The ZL6105 eliminates the need for complicated power supply managers as well as numerous external discrete components.

The ZL6105 uses the I²C/SMBus™ with PMBus™ protocol for communication with a host controller and the Digital-DC bus for communication between Zilker Labs devices.

The ZL6105 is pin for pin compatible with the ZL2008. The POLA V_{OUT} table and compensation table have been removed. A new single resistor V_{OUT} table and the Auto Compensation feature have been added.

Applications

- Servers/Storage Equipment
- Telecom/Datacom Equipment
- Power Supply Modules

Features

Power Conversion

- Efficient Synchronous Buck Controller
- Auto Compensating PID Filter
- Adaptive Light Load Efficiency Optimization
- 3V to 14V Input Range
- 0.54V to 5.5V Output Range (with margin)
- ±1% Output Voltage Accuracy
- Internal 3A MOSFET Drivers
- Fast Load Transient Response
- Current Sharing and Phase Interleaving
- Snapshot™ Parameter Capture
- Pb-Free (RoHS Compliant)

Power Management

- Digital Soft-start/stop
- Power-Good/Enable
- Voltage Tracking, Sequencing and Margining
- Voltage, Current and Temperature Monitoring
- I²C/SMBus Interface, PMBus Compatible
- Output Voltage and Current Protection
- Internal Non-volatile Memory (NVM)

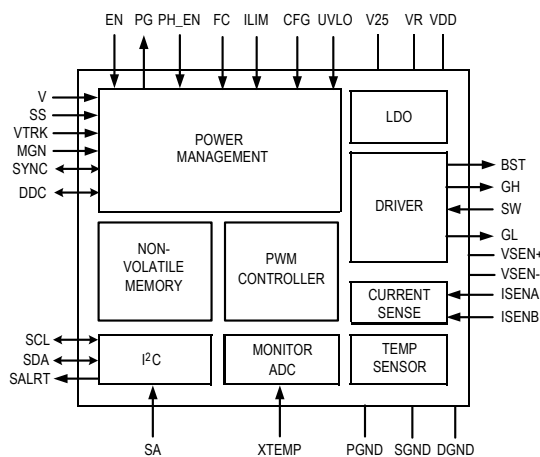

FIGURE 1. BLOCK DIAGRAM

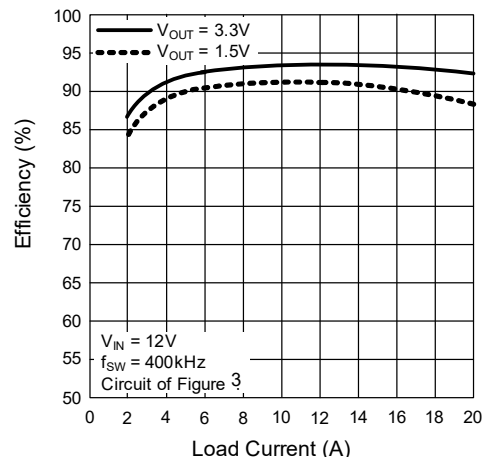

FIGURE 2. EFFICIENCY vs LOAD CURRENT

Table of Contents

Typical Application Circuit	3
Pin Descriptions	5
Absolute Maximum Ratings	7
Thermal Information	7
Recommended Operating Conditions	7
Electrical Specifications	7
ZL6105 Overview	10
Digital-DC Architecture	10
Power Conversion Overview	10
Power Management Overview	11
Multi-mode Pins	11
Power Conversion Functional Description	12
Internal Bias Regulators and Input Supply Connections	12
High-side Driver Boost Circuit	12
Output Voltage Selection	12
Single Resistor Output Voltage Setting Mode	13
SMBus Mode	13
Start-up Procedure	13
Soft-Start Delay and Ramp Times	14
Power-Good	15
Switching Frequency and PLL	15
Power Train Component Selection	16
Current Limit Threshold Selection	19
Loop Compensation	20
Non-linear Response (NLR) Settings	22
Efficiency Optimized Driver Dead-time Control	22
Adaptive Diode Emulation	22
Power Management Functional Description	22
Input Undervoltage Lockout	22
Output Overvoltage Protection	23
Output Pre-Bias Protection	23
Output Overcurrent Protection	24
Thermal Overload Protection	24
Voltage Tracking	24
Voltage Margining	25
I2C/SMBus Communications	25
I2C/SMBus Device Address Selection	26
Digital-DC Bus	26
Phase Spreading	27
Output Sequencing	28
Fault Spreading	28
Temperature Monitoring Using the XTEMP Pin	28
Active Current Sharing	28
Phase Adding/Dropping	31
Monitoring via I2C/SMBus	31
Snapshot Parameter Capture	31
Non-Volatile Memory and Device Security Features	32
License Information	32
Revision History	33
Package Outline Drawing	35

Typical Application Circuit

The following application circuit represents a typical implementation of the ZL6105. For enable using the PMBus, it is recommended to tie the enable pin (EN) to SGND.

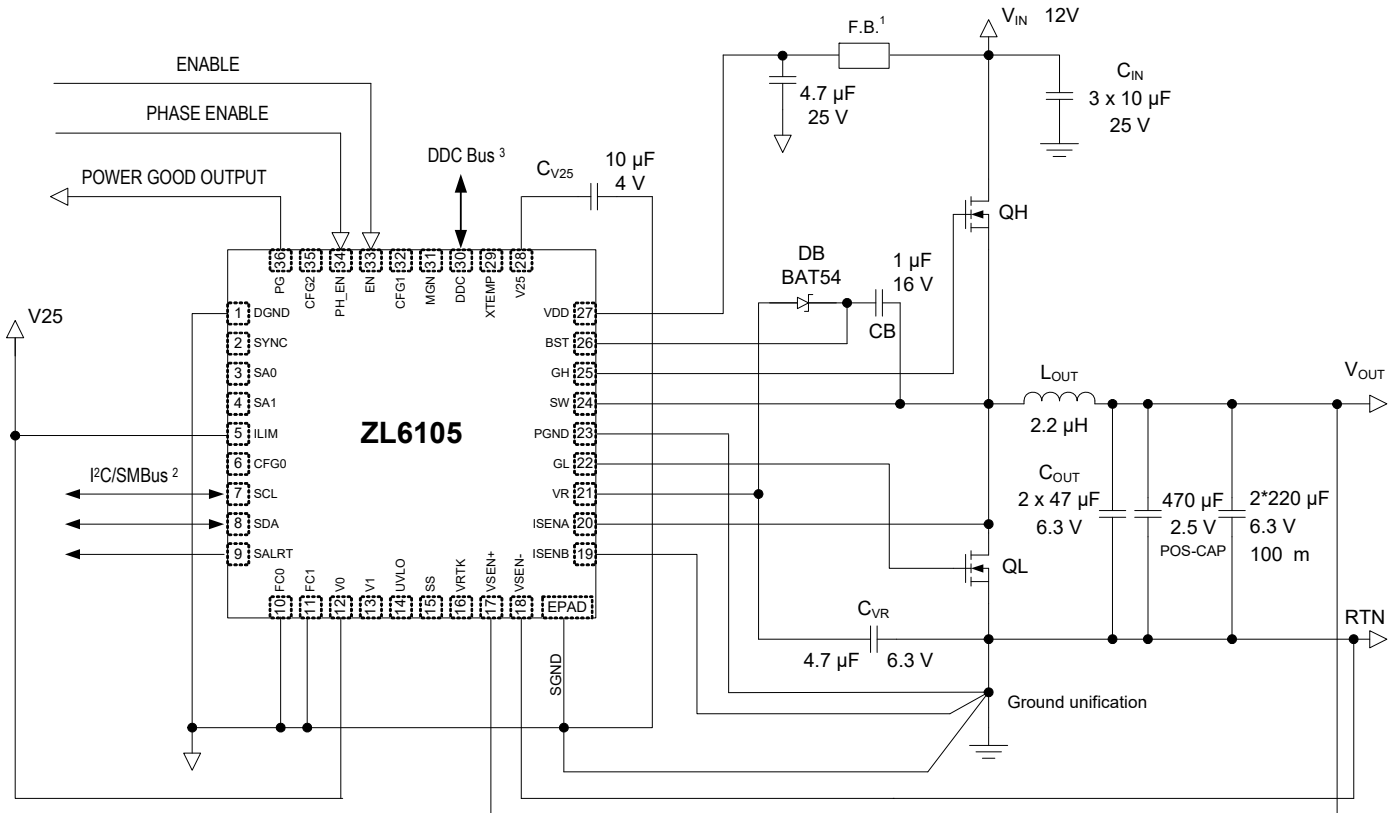

- Notes:**
1. Ferrite bead is optional for input noise suppression
 2. The I²C/SMBus requires pull-up resistors. Please refer to the I²C/SMBus specifications for more details.
 3. The DDC bus requires a pull-up resistor. The resistance will vary based on the capacitive loading of the bus (and on the number of devices connected). The 10 kΩ default value, assuming a maximum of 100 pF per device, provides the necessary 1 μs pull-up rise time. Please refer to the DDC Bus section for more details.

FIGURE 3. 12V TO 1.8V/16A APPLICATION CIRCUIT

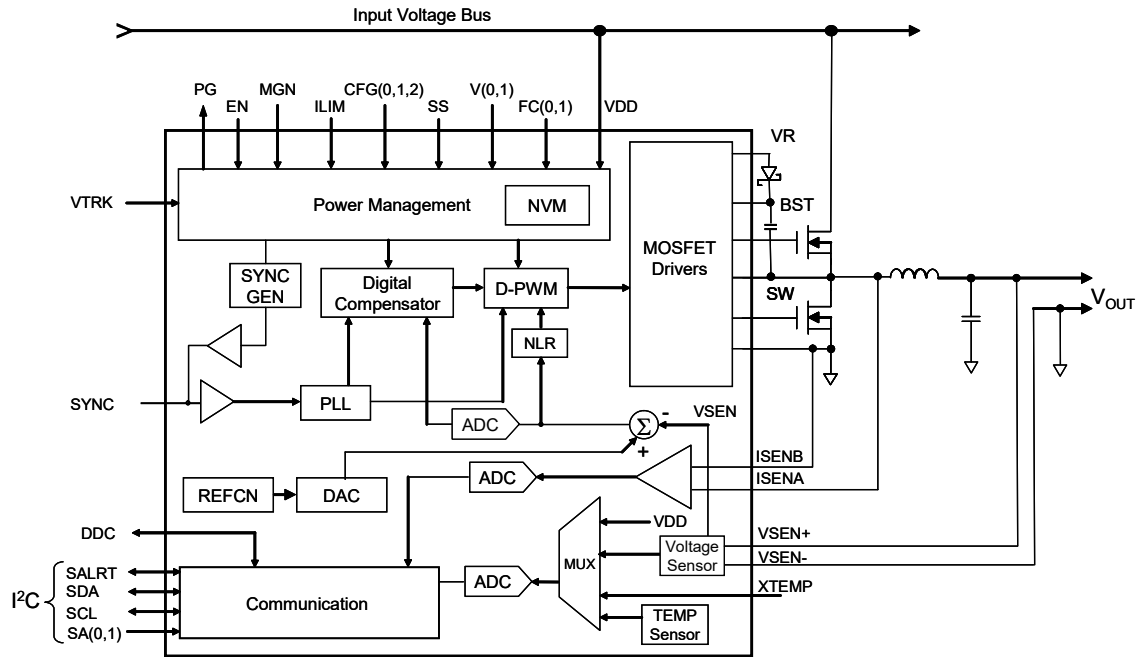
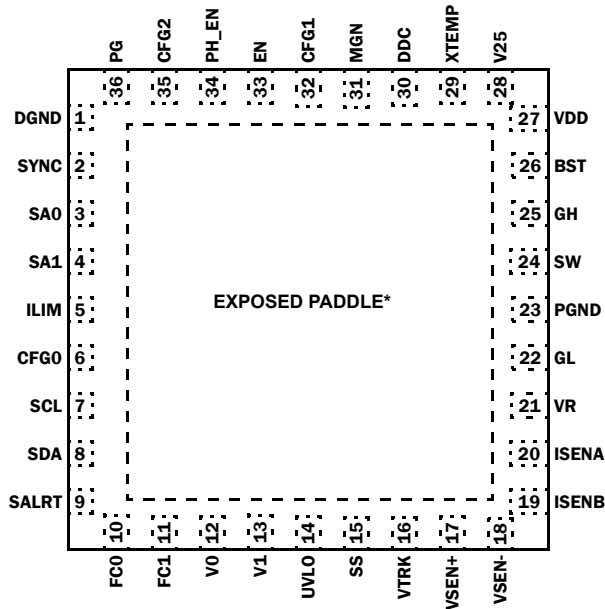

FIGURE 4. ZL6105 BLOCK DIAGRAM

Pin Configuration

ZL6105
(36 LD QFN)
TOP VIEW



Pin Descriptions

PIN	LABEL	TYPE (Note 1)	DESCRIPTION
1	DGND	PWR	Digital ground. Common return for digital signals. Connect to low impedance ground plane.
2	SYNC	I/O,M (Note 2)	Clock synchronization input. Used to set switching frequency of internal clock or for synchronization to external frequency reference.
3	SA0	I, M	Serial address select pins. Used to assign unique SMBus address to each IC or to enable certain management features.
4	SA1		
5	ILIM	I, M	Current limit select. Sets the overcurrent threshold voltage for ISENA and ISENB.
6	CFG0	I, M	Configuration pin. Used to setup current sharing and non-linear response.
7	SCL	I/O	Serial clock. Connect to external host and/or to other ZL devices.
8	SDA	I/O	Serial data. Connect to external host and/or to other ZL devices.
9	SALRT	O	Serial alert. Connect to external host if desired.
10	FC0	I	Loop compensation configuration pins.
11	FC1		
12	V0	I	Output voltage selection pins. Used to set V_{OUT} set-point and V_{OUT} max.
13	V1		
14	UVLO	I, M	Undervoltage lockout selection. Sets the minimum value for V_{DD} voltage to enable V_{OUT} .
15	SS	I, M	Soft start pin. Sets the output voltage ramp time during turn-on and turn-off. Sets the delay from when EN is asserted until the output voltage starts to ramp.
16	VTRK	I	Tracking sense input. Used to track an external voltage source.
17	VSEN+	I	Output voltage feedback. Connect to output regulation point.
18	VSEN-	I	Output voltage feedback. Connect to load return or ground regulation point.
19	ISENB	I	Differential voltage input for current limit.
20	ISENA	I	Differential voltage input for current limit. High voltage tolerant.
21	VR	PWR	Internal 5V reference used to power internal drivers.
22	GL	O	Low side FET gate drive.
23	PGND	PWR	Power ground. Connect to low impedance ground plane.
24	SW	PWR	Drive train switch node.
25	GH	O	High-side FET gate drive.
26	BST	PWR	High-side drive boost voltage.
27	VDD (Note 3)	PWR	Supply voltage.
28	V25	PWR	Internal 2.5V reference used to power internal circuitry.
29	XTEMP	I	External temperature sensor input. Connect to external 2N3904 diode connected transistor.
30	DDC	I/O	Digital-DC Bus. (Open Drain) Interoperability between Zilker Labs devices.
31	MGN	I	Signal that enables margining of output voltage.
32	CFG1	I, M	Configuration pin. Used to setup clock synchronization and sequencing.
33	EN	I	Enable input (active high). Pull-up to enable PWM switching and pull-down to disable PWM switching.
34	PH_EN	I	Phase enable input (active high). Pull-up to enable phase and pull-down to disable phase for current sharing.
35	CFG2	I, M	Configuration pin. Sets the phase offset (single-phase) or current sharing group position (multi-phase).
36	PG	O	Power-good output.
ePad	SGND	PWR	Exposed thermal pad. Common return for analog signals; internal connection to SGND. Connect to low impedance ground plane.

NOTES:

1. I = Input, O = Output, PWR = Power or Ground. M = Multi-mode pin dependents. (Refer to "Multi-mode Pins" on page 11).
2. The SYNC pin can be used as a logic pin, a clock input or a clock output.
3. V_{DD} is measured internally and the value is used to modify the PWM loop gain.

Ordering Information

PART NUMBER (Notes 5, 6)	PART MARKING	PACKAGE DESCRIPTION (RoHS Compliant)	PKG. DWG. #	CARRIER TYPE (Note 4)	TEMP. RANGE
ZL6105ALAF	6105	36 Ld QFN	L36.6x6A	Tube	-40 to +85 °C
ZL6105ALAFT				Reel, 100	
ZL6105ALAFTK				Reel, 1k	

NOTES:

4. See [TB347](#) for details about reel specifications.
5. These Pb-free plastic packaged products employ special Pb-free material sets, molding compounds/die attach materials, and 100% matte tin plate plus anneal (e3 termination finish, which is RoHS compliant and compatible with both SnPb and Pb-free soldering operations). Pb-free products are MSL classified at Pb-free peak reflow temperatures that meet or exceed the Pb-free requirements of IPC/JEDEC J STD-020.
6. For Moisture Sensitivity Level (MSL), see the [ZL6105](#) device information page. For more information on MSL, see [TB363](#).

Absolute Maximum Ratings (Note 7)

DC Supply Voltage for VDD Pin	-0.3V to 17V
MOSFET Drive Reference for VR Pin @ 120mA	-0.3V to 6.5V
2.5V Logic Reference for V25 Pin @ 120mA	-0.3V to 3V
Logic I/O Voltage for CFG(0,1,2), DDC, EN, FC(0, 1), ILIM, MGN, PG, PH_EN, SA(0, 1), SALRT, SCL, SDA, SS, SYNC, UVLO, V(0,1) Pins	-0.3V to 6.5V
Analog Input Voltages for ISENB, VSEN, VTRK, XTEMP Pins	-0.3V to 6.5V
Analog Input Voltages for ISENA Pin	-1.5V to 30V
High Side Supply Voltage for BST Pin	-0.3V to 30V
Boost to Switch Voltage for BST - SW Pins	-0.3V to 8V
High Side Drive Voltage for GH Pin($V_{SW} - 0.3V$) to ($V_{BST} + 0.3V$)	
Low Side Drive Voltage for GL Pin (PGND - 0.3V) to VR + 0.3V	
Switch Node for SW Pin	
Continuous(PGND - 0.3V) to 30V
Transient (<100ns) (PGND - 5V) to 30V
Ground Voltage Differential (DGND - SGND, PGND - SGND) for DGND, SGND and PGND Pins	-0.3V to +0.3V
ESD Rating	
Human Body Model (Note 8) 2kV
Machine Model 200V
Latch-up Tested to JESD78

CAUTION: Do not operate at or near the maximum ratings listed for extended periods of time. Exposure to such conditions can adversely impact product reliability and result in failures not covered by warranty.

NOTES:

7. Voltage measured with respect to SGND.
8. BST, SW pins rated at 1.5kV.
9. θ_{JA} is measured in free air with the component mounted on a high-effective thermal conductivity test board with direct attach features. See [TB379](#).
10. For θ_{JC} , the case temperature location is the center of the exposed metal pad on the package underside.
11. Includes margin limits.

Electrical Specifications $V_{DD} = 12V$, $T_A = -40^\circ C$ to $+85^\circ C$ unless otherwise noted. Typical values are at $T_A = +25^\circ C$. **Boldface limits apply over the operating temperature range, $-40^\circ C$ to $+85^\circ C$.**

PARAMETER	CONDITIONS	MIN (Note 19)	TYP	MAX (Note 19)	UNIT
Input and Supply Characteristics					
I_{DD} Supply Current at $f_{SW} = 200kHz$	GH, GL no load	-	16	30	mA
I_{DD} Supply Current at $f_{SW} = 1.4Mhz$		-	25	50	mA
I_{DDs} Shutdown Current	EN = 0V No I ² C/SMBus activity	-	6.5	9	mA
Vr Reference Output Voltage	$V_{DD} > 6V$, $I_{VR} < 20mA$	4.5	5.2	5.5	V
V25 Reference Output Voltage	$V_R > 3V$, $I_{V25} < 20mA$	2.25	2.5	2.75	V
Output Characteristics					
Output Voltage Adjustment Range (Note 12)	$V_{IN} > V_{OUT}$	0.6	-	5.0	V
Output Voltage Set-point Resolution	Set using resistors	-	10	-	mV
	Set using I ² C/SMBus	-	±0.025	-	% FS (Note 13)
Output Voltage Accuracy (Note 14)	Includes line, load, temp	-1	-	1	%
Vsen Input Bias Current	VSEN = 5.5V	-	110	200	µA
Current Sense Differential Input Voltage (Ground Referenced)	$V_{ISENA} - V_{ISENB}$	-100	-	100	mV
Current Sense Differential Input Voltage (V_{out} Referenced, $V_{out} < 4.0V$)	$V_{ISENA} - V_{ISENB}$	-50	-	50	mV
Current Sense Input Bias Current	Ground referenced	-100	-	100	µA

Thermal Information

Thermal Resistance (Typical)	θ_{JA} ($^\circ C/W$)	θ_{JC} ($^\circ C/W$)
36 Ld QFN (Notes 9, 10)	35	5
Operating Junction Temperature Range	-40 $^\circ C$ to +125 $^\circ C$	
Junction Temperature	-55 $^\circ C$ to +150 $^\circ C$	
Storage Temperature Range	-55 $^\circ C$ to +150 $^\circ C$	
Pb-Free Reflow Profile	see TB493	

Recommended Operating Conditions

Input Supply Voltage Range, V_{DD} (see Figure 8)	
V_{DD} tied to V_R	3.0V to 5V
V_R floating	4.5V to 14V
Output Voltage Range (V_{OUT}) (Note 11)	0.54V to 5.5V
Junction Temperature	-40 $^\circ C$ to +125 $^\circ C$

Electrical Specifications $V_{DD} = 12V$, $T_A = -40^\circ C$ to $+85^\circ C$ unless otherwise noted. Typical values are at $T_A = +25^\circ C$. **Boldface limits apply over the operating temperature range, $-40^\circ C$ to $+85^\circ C$.** (Continued)

PARAMETER	CONDITIONS	MIN (Note 19)	TYP	MAX (Note 19)	UNIT
Current Sense Input Bias Current (V_{out} Referenced, $V_{out} < 4.0V$)	ISENA	-1	-	1	μA
	ISENB	-100	-	100	μA
Soft-start Delay Duration Range	Set using SS pin or resistor (Note 15)	5	-	30	ms
	Set using I ² C/SMBus (Note 15)	0.005	-	500	s
Soft-start Delay Duration Accuracy	Turn-on delay (Note 15)	-	-0.25/+4	-	ms
	Turn-off delay (Note 15)	-	-0.25/+4	-	ms
Soft-start Ramp Duration Range	Set using SS pin or resistor	2	-	20	ms
	Set using I ² C	0	-	200	ms
Soft-start Ramp Duration Accuracy		-	100	-	μs
Logic Input/Output Characteristics					
Logic Input Leakage Current	EN, SCL, SDA pins	-250	-	250	nA
Logic Input Low, V_{IL}		-	-	0.8	V
Logic Input OPEN (N/C)	Multi-mode logic pins	-	1.4	-	V
Logic Input High, V_{IH}		2.0	-	-	V
Logic Output Low, V_{OL}	$I_{OL} \leq 4mA$ (Note 20)	-	-	0.4	V
Logic Output High, V_{OH}	$I_{OH} \geq -2mA$ (Note 20)	2.25	-	-	V
Oscillator and Switching Characteristics					
Switching Frequency Range		200	-	1400	kHz
Switching Frequency Set-point Accuracy	Predefined settings (See Table 11)	-5	-	5	%
Maximum Pwm Duty Cycle	Factory default	95	-	-	%
Minimum Sync Pulse Width		150	-	-	ns
Input Clock Frequency Drift Tolerance	External clock source	-13	-	13	%
Gate Drivers					
High-side driver voltage ($V_{BST} - V_{SW}$)		-	4.5	-	V
High-side Driver Peak Gate Drive Current (Pull-down)	$(V_{BST} - V_{SW}) = 4.5V$	2	3	-	A
High-side Driver Pull-up Resistance	$(V_{BST} - V_{SW}) = 4.5V$, $(V_{BST} - V_{GH}) = 50mV$	-	0.8	2	Ω
High-side Driver Pull-down Resistance	$(V_{BST} - V_{SW}) = 4.5V$, $(V_{GH} - V_{SW}) = 50mV$	-	0.5	2	Ω
Low-side Driver Peak Gate Drive Current (Pull-up)	$V_R = 5V$	-	2.5	-	A
Low-side Driver Peak Gate Drive Current (Pull-down)	$V_R = 5V$	-	1.8	-	A
Low-side Driver Pull-up Resistance	$V_R = 5V$, $(V_R - V_{GL}) = 50mV$	-	1.2	2	Ω
Low-side Driver Pull-down Resistance	$V_R = 5V$, $(V_{GL} - PGND) = 50mV$	-	0.5	2	Ω
Switching Timing					
Gh Rise and Fall Time	$(V_{BST} - V_{SW}) = 4.5V$, $C_{LOAD} = 2.2nF$	-	5	20	ns
Gl Rise and Fall Time	$V_R = 5V$, $C_{LOAD} = 2.2nF$	-	5	20	ns
Tracking					
VTRK Input Bias Current	VTRK = 5.5V	-	110	200	μA
VTRK Tracking Ramp Accuracy	100% Tracking, $V_{OUT} - VTRK$, no prebias	-100	-	+100	mV
VTRK Regulation Accuracy	100% Tracking, $V_{OUT} - VTRK$	-1	-	1	%
Fault Protection Characteristics					
UVLO Threshold Range	Configurable via I ² C/SMBus	2.85	-	16	V
UVLO Set-point Accuracy		-150	-	150	mV
UVLO Hysteresis	Factory default	-	3	-	%
	Configurable via I ² C/SMBus	0	-	100	%

Electrical Specifications $V_{DD} = 12V$, $T_A = -40^{\circ}C$ to $+85^{\circ}C$ unless otherwise noted. Typical values are at $T_A = +25^{\circ}C$. **Boldface limits apply over the operating temperature range, $-40^{\circ}C$ to $+85^{\circ}C$. (Continued)**

PARAMETER	CONDITIONS	MIN (Note 19)	TYP	MAX (Note 19)	UNIT
UVLO Delay		-	2.5	-	μs
Power Good V_{OUT} Threshold	Factory default	-	90	-	% V_{OUT}
Power Good V_{OUT} Hysteresis	Factory default	-	5	-	%
Power Good Delay	Using pin-strap or resistor (Note 16)	0	-	200	ms
	Configurable via I ² C/SMBus	0	-	500	s
VSEN Undervoltage Threshold	Factory default	-	85	-	% V_{OUT}
	Configurable via I ² C/SMBus	0	-	110	% V_{OUT}
VSEN Overvoltage Threshold	Factory default	-	115	-	% V_{OUT}
	Configurable via I ² C/SMBus	0	-	115	% V_{OUT}
VSEN Undervoltage Hysteresis		-	5	-	% V_{OUT}
VSEN Undervoltage/Overvoltage Fault Response Time	Factory default	-	16	-	μs
	Configurable via I ² C/SMBus	5	-	60	μs
Current Limit Set-point Accuracy (V_{OUT} Referenced)		-	± 10	-	% FS (Note 17)
Current Limit Set-point Accuracy (Ground Referenced)		-	± 10	-	% FS (Note 17)
Current Limit Protection Delay	Factory default	-	10	-	t_{SW} (Note 18)
	Configurable via I ² C/SMBus	1	-	32	t_{SW} (Note 18)
Temperature Compensation of Current Limit Protection Threshold	Factory default		4400		ppm/ $^{\circ}C$
	Configurable via I ² C/SMBus	100		12700	
Thermal Protection Threshold (Junction Temperature)	Factory default	-	125	-	$^{\circ}C$
	Configurable via I ² C/SMBus	-40	-	125	$^{\circ}C$
Thermal Protection Hysteresis		-	15	-	$^{\circ}C$

NOTES:

12. Does not include margin limits.
13. Percentage of Full Scale (FS) with temperature compensation applied.
14. V_{OUT} measured at the termination of the VSEN+ and VSEN-sense points.
15. The device requires a minimum delay period following an enable signal and prior to ramping its output as described in "Soft-Start Delay and Ramp Times" on page 14.
16. Factory default Power Good delay is set to the same value as the soft-start ramp time. Refer to "Soft-Start Delay and Ramp Times" on page 14 for further restrictions on PG Delay.
17. Percentage of Full Scale (FS) with temperature compensation applied
18. $t_{SW} = 1/f_{SW}$, where f_{SW} is the switching frequency.
19. Compliance to datasheet limits is assured by one or more methods: production test, characterization and/or design.
20. Nominal capacitance of logic pins is 5pF.

ZL6105 Overview

Digital-DC Architecture

The ZL6105 is an innovative mixed-signal power conversion and power management IC based on Zilker Labs patented Digital-DC technology that provides an integrated, high performance step-down converter for a wide variety of power supply applications.

Today's embedded power systems are typically designed for optimal efficiency at maximum load, reducing the peak thermal stress by limiting the total thermal dissipation inside the system.

Unfortunately, many of these systems are often operated at load levels far below the peak where the power system has been optimized, resulting in reduced efficiency. While this may not cause thermal stress to occur, it does contribute to higher electricity usage and results in higher overall system operating costs.

Zilker Labs' efficiency-adaptive ZL6105 DC/DC controller helps mitigate this scenario by enabling the power converter to automatically change their operating state to increase efficiency and overall performance with little or no user interaction needed. Auto compensation is available to eliminate the need for manual compensation of the PID filter.

Its unique PWM loop utilizes an ideal mix of analog and digital blocks to enable precise control of the entire power conversion process with no software required, resulting in a very flexible device that is also very easy to use. An extensive set of power management functions are fully integrated and can be configured using simple pin connections. The user configuration can be saved in an internal non-volatile memory (NVM). Additionally, all functions can be configured and monitored using the SMBus hardware interface using standard PMBus commands, allowing ultimate flexibility.

Once enabled, the ZL6105 is immediately ready to regulate power and perform power management tasks with no programming required. Advanced configuration options and real-time configuration changes are available via the I²C/SMBus interface if desired and continuous monitoring of multiple operating parameters is possible with minimal interaction from a host controller. Integrated sub-regulation circuitry enables single supply operation from any supply between 3V and 14V with no secondary bias supplies needed.

The ZL6105 can be configured by simply connecting its pins according to the tables provided in the following sections. Additionally, a comprehensive set of development tools and application notes are available to help simplify the design process. An evaluation board is also available to help the user become familiar with the device. This board can be evaluated as a standalone platform using pin configuration settings. A Windows™ based GUI is also provided to enable full configuration and monitoring capability via the I²C/SMBus interface using an available computer and the included USB cable.

Application notes are available to assist the user in designing to specific application demands. Please visit [ZL6105](#) to access the most up-to-date documentation.

Power Conversion Overview

The ZL6105 operates as a voltage-mode, synchronous buck converter with a selectable constant frequency pulse width modulator (PWM) control scheme that uses external MOSFETs, capacitors, and an inductor to perform power conversion.

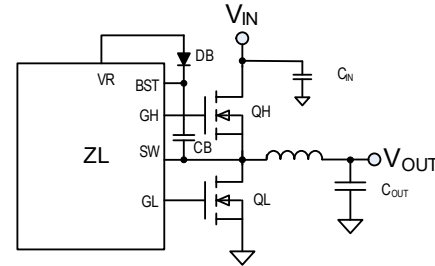

FIGURE 5. SYNCHRONOUS BUCK CONVERTER

Figure 5 illustrates the basic synchronous buck converter topology showing the primary power train components. This converter is also called a step-down converter, as the output voltage must always be lower than the input voltage. In its most simple configuration, the ZL6105 requires two external N-channel power MOSFETs, one for the top control MOSFET (QH) and one for the bottom synchronous MOSFET (QL). The amount of time that QH is on as a fraction of the total switching period is known as the duty cycle *D*, which is described by Equation 1:

$$D \approx \frac{V_{OUT}}{V_{IN}} \quad (\text{EQ. 1})$$

During time *D*, QH is on and $V_{IN} - V_{OUT}$ is applied across the inductor. The current ramps up as shown in Figure 6.

When QH turns off (time 1-*D*), the current flowing in the inductor must continue to flow from the ground up through QL, during which the current ramps down. Since the output capacitor C_{OUT} exhibits a low impedance at the switching frequency, the AC component of the inductor current is filtered from the output voltage so the load sees nearly a DC voltage.

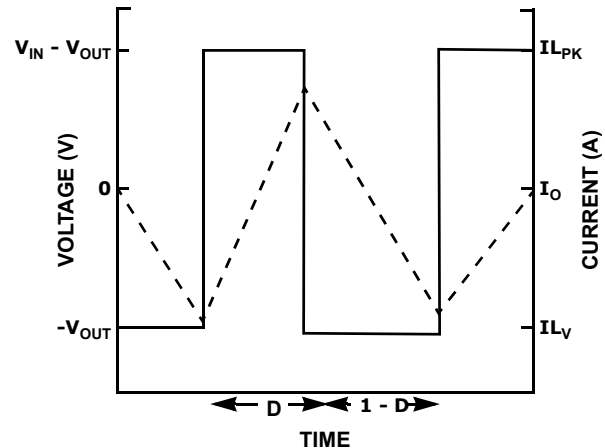

FIGURE 6. INDUCTOR WAVEFORM

Typically, buck converters specify a maximum duty cycle that effectively limits the maximum output voltage that can be realized for a given input voltage. This duty cycle limit ensures that the low-side MOSFET is allowed to turn on for a minimum amount of time during each switching cycle, which enables the bootstrap capacitor (CB in Figure 6) to be charged up and provide adequate

gate drive voltage for the high-side MOSFET. See “High-side Driver Boost Circuit” on page 12 for more details.

In general, the size of components L1 and C_{OUT} as well as the overall efficiency of the circuit are inversely proportional to the switching frequency, f_{SW}. Therefore, the highest efficiency circuit may be realized by switching the MOSFETs at the lowest possible frequency; however, this will result in the largest component size. Conversely, the smallest possible footprint may be realized by switching at the fastest possible frequency but this gives a somewhat lower efficiency. Each user should determine the optimal combination of size and efficiency when determining the switching frequency for each application.

The block diagram for the ZL6105 is illustrated in Figure 4. In this circuit, the target output voltage is regulated by connecting the differential VSEN pins directly to the output regulation point. The VSEN signal is then compared to a reference voltage that has been set to the desired output voltage level by the user. The error signal derived from this comparison is converted to a digital value with a low-resolution, analog to digital (A/D) converter. The digital signal is applied to an adjustable digital compensation filter, and the compensated signal is used to derive the appropriate PWM duty cycle for driving the external MOSFETs in a way that produces the desired output.

The ZL6105 has several features to improve the power conversion efficiency. A non-linear response (NLR) loop improves the response time and reduces the output deviation as a result of a load transient. The ZL6105 monitors the power converter's operating conditions and continuously adjusts the turn-on and turn-off timing of the high-side and low-side MOSFETs to optimize the overall efficiency of the power supply. Adaptive performance optimization algorithms such as dead-time control, diode emulation, and frequency control are available to provide greater efficiency improvement.

Power Management Overview

The ZL6105 incorporates a wide range of configurable power management features that are simple to implement with no external components. Additionally, the ZL6105 includes circuit protection features that continuously safeguard the device and load from damage due to unexpected system faults. The ZL6105 can continuously monitor input voltage, output voltage/current, internal temperature, and the temperature of an external thermal diode. A Power-Good output signal is also included to enable power-on reset functionality for an external processor.

All power management functions can be configured using either pin configuration techniques (see Figure 8) or via the I²C/SMBus interface. Monitoring parameters can also be pre-configured to provide alerts for specific conditions. See Application Note [AN2033](#) for more details on SMBus monitoring.

Multi-mode Pins

In order to simplify circuit design, the ZL6105 incorporates patented multi-mode pins that allow the user to easily configure many aspects of the device with no programming. Most power management features can be configured using these pins. The multi-mode pins can respond to four different connections as shown in Table 1. These pins are sampled when power is applied or by issuing a PMBus Restore command (see Application Note AN2033).

PIN-STRAP SETTINGS

This is the simplest implementation method, as no external components are required. Using this method, each pin can take on one of three possible states: LOW, OPEN, or HIGH. These pins can be connected to the V25 pin for logic HIGH settings as this pin provides a regulated voltage higher than 2V. Using a single pin, one of three settings can be selected. Using two pins, one of nine settings can be selected.

TABLE 1. MULTI-MODE PIN CONFIGURATION

PIN TIED TO	VALUE
LOW (Logic LOW)	< 0.8 VDC
OPEN (N/C)	No connection
HIGH (Logic HIGH)	> 2.0 VDC
Resistor to SGND	Set by resistor value

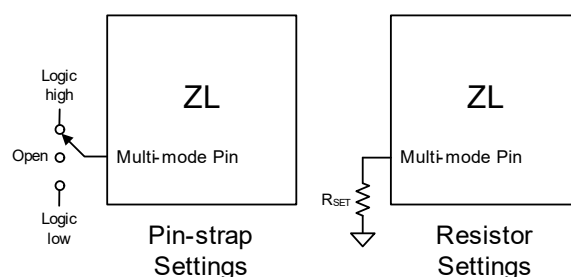

FIGURE 7. PIN-STRAP AND RESISTOR SETTING EXAMPLES

RESISTOR SETTINGS

This method allows a greater range of adjustability when connecting a finite value resistor (in a specified range) between the multi-mode pin and SGND. Standard 1% resistor values are used, and only every fourth E96 resistor value is used so the device can reliably recognize the value of resistance connected to the pin while eliminating the error associated with the resistor accuracy. Up to 31 unique selections are available using a single resistor.

I²C/SMBUS METHOD

Almost any ZL6105 function can be configured via the I²C/SMBus interface using standard PMBus commands. Additionally, any value that has been configured using the pin-strap or resistor setting methods can also be re-configured and/or verified via the I²C/SMBus. See Application Note AN2033 for more details.

The SMBus device address and VOUT_MAX are the only parameters that must be set by external pins. All other device parameters can be set via the I²C/SMBus. The device address is set using the SA0 and SA1 pins. VOUT_MAX is determined as 10% greater than the voltage set by the V0 and V1 pins.

Power Conversion Functional Description

Internal Bias Regulators and Input Supply Connections

The ZL6105 employs two internal low dropout (LDO) regulators to supply bias voltages for internal circuitry, allowing it to operate from a single input supply. The internal bias regulators are as indicated in the following:

VR - The VR LDO provides a regulated 5V bias supply for the MOSFET driver circuits. It is powered from the VDD pin. A 4.7µF filter capacitor is required at the VR pin.

V25 - The V25 LDO provides a regulated 2.5V bias supply for the main controller circuitry. It is powered from an internal 5V node. A 10µF filter capacitor is required at the V25 pin.

When the input supply (VDD) is higher than 5.5V, the VR pin should not be connected to any other pins. It should only have a filter capacitor attached as shown in Figure 8. Due to the dropout voltage associated with the VR bias regulator, the VDD pin must be connected to the VR pin for designs operating from a supply below 5.5V. Figure 8 illustrates the required connections for both cases.

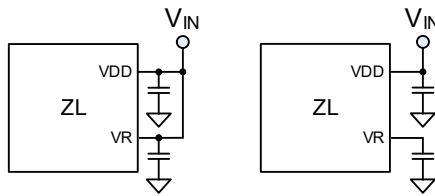

3V ≤ V_{IN} ≤ 5.5V 5.5V < V_{IN} ≤ 14V
FIGURE 8. INPUT SUPPLY CONNECTIONS

Note: the internal bias regulators are not designed to be outputs for powering other circuitry. Do not attach external loads to any of these pins. The multi-mode pins may be connected to the V25 pin for logic HIGH settings.

High-side Driver Boost Circuit

The gate drive voltage for the high-side MOSFET driver is generated by a floating bootstrap capacitor, CB (see Figure 5). When the lower MOSFET (QL) is turned on, the SW node is pulled to ground and the capacitor is charged from the internal VR bias regulator through diode DB. When QL turns off and the upper MOSFET (QH) turns on, the SW node is pulled up to V_{DD} and the voltage on the bootstrap capacitor is boosted approximately 5V above V_{DD} to provide the necessary voltage to power the high-side driver. A Schottky diode should be used for DB to help maximize the high-side drive supply voltage.

Output Voltage Selection

STANDARD MODE

The output voltage may be set to any voltage between 0.6V and 5.0V provided that the input voltage is higher than the desired output voltage by an amount sufficient to prevent the device from exceeding its maximum duty cycle specification. Using the pin-strap method, V_{OUT} can be set to any of nine standard voltages as shown in Table 2.

TABLE 2. OUTPUT VOLTAGE PIN-STRAP SETTINGS

		V0		
		LOW	OPEN	HIGH
V1	LOW	0.6V	0.8V	1.0V
	OPEN	1.2V	1.5V	1.8V
	HIGH	2.5V	3.3V	5.0V

The resistor setting method can be used to set the output voltage to levels not available in Table 2. Resistors R₀ and R₁ are selected to produce a specific voltage between 0.6V and 5.0V in 10mV steps. Resistor R₁ provides a coarse setting and resistor R₀ provides a fine adjustment, thus eliminating the additional errors associated with using two 1% resistors (this typically adds approximately 1.4% error).

To set V_{OUT} using resistors, follow the steps indicated to calculate an index value and then use Table 3 to select the resistor that corresponds to the calculated index value as follows:

1. Calculate Index1:

$$\text{Index1} = 4 \times \text{VOUT} \quad (\text{VOUT in 10mV steps}) \quad (\text{EQ. 2})$$
2. Round the result down to the nearest whole number.
3. Select the value of R₁ from Table 3 using the Index1 rounded value from step 2.
4. Calculate Index0:

$$\text{Index0} = 100 \times \text{VOUT} - (25 \times \text{Index1}) \quad (\text{EQ. 3})$$
5. Select the value of R₀ from Table 3 using the Index0 value from step 4.

TABLE 3. OUTPUT VOLTAGE RESISTORS SETTINGS

INDEX	R0 OR R1 (kΩ)	INDEX	R0 OR R1 (kΩ)
0	10	13	34.8
1	11	14	38.3
2	12.1	15	42.2
3	13.3	16	46.4
4	14.7	17	51.1
5	16.2	18	56.2
6	17.8	19	61.9
7	19.6	20	68.1
8	21.5	21	75
9	23.7	22	82.5
10	26.1	23	90.9
11	28.7	24	100
12	31.6		

Example from Figure 9: For V_{OUT} = 1.33V,

Index1 = 4 × 1.33V = 5.32;
 From Table 3, R₁ = 16.2kΩ

Index0 = (100 × 1.33V) - (25 × 5) = 8;
 From Table 3, R₀ = 21.5kΩ

The output voltage can be determined from the R_0 (Index0) and R_1 (Index1) values using Equation 4:

$$V_{OUT} = \frac{Index0 + (25 \times Index1)}{100} \quad (EQ. 4)$$

Single Resistor Output Voltage Setting Mode

Some applications desire the output voltage to be set using a single resistor. This can be accomplished using a resistor on the V1 pin while the V0 pin is tied to SGND. Table 4 lists the available output voltage settings with a single resistor.

SMBus Mode

The output voltage may be set to any value between 0.6V and 5.0V using a PMBus command over the I²C/SMBus interface. See Application Note AN2033 for details.

Start-up Procedure

The ZL6105 follows a specific internal start-up procedure after power is applied to the VDD pin. Table 5 describes the start-up sequence.

TABLE 4. SINGLE RESISTOR V_{OUT} SETTING

R_{V1} (k Ω)	R_{V0}	V_{OUT}
10	LOW	0.60
11	LOW	0.65
12.1	LOW	0.70
13.3	LOW	0.75
14.7	LOW	0.80
16.2	LOW	0.85
17.8	LOW	0.90
19.6	LOW	0.95
21.5	LOW	1.00
23.7	LOW	1.05
26.1	LOW	1.10
28.7	LOW	1.15
31.6	LOW	1.20
34.8	LOW	1.25
38.3	LOW	1.30
42.2	LOW	1.40
46.4	LOW	1.50
51.1	LOW	1.60
56.2	LOW	1.70
61.9	LOW	1.80
68.1	LOW	1.90
75	LOW	2.00
82.5	LOW	2.10
90.9	LOW	2.20
100	LOW	2.30
110	LOW	2.50
121	LOW	3.00

TABLE 4. SINGLE RESISTOR V_{OUT} SETTING (Continued)

R_{V1} (k Ω)	R_{V0}	V_{OUT}
133	LOW	3.30
147	LOW	4.00
162	LOW	5.00
178	LOW	5.50

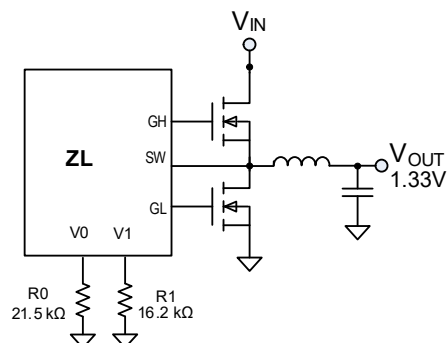

FIGURE 9. OUTPUT VOLTAGE RESISTOR SETTING EXAMPLE

If the device is to be synchronized to an external clock source, the clock frequency must be stable prior to asserting the EN pin. The device requires approximately 5ms to 10ms to check for specific values stored in its internal memory. If the user has stored values in memory, those values will be loaded. The device will then check the status of all multi-mode pins and load the values associated with the pin settings.

Once this process is completed, the device is ready to accept commands via the I²C/SMBus interface and the device is ready to be enabled. Once enabled, the device requires a minimum delay period following an enable signal and prior to ramping its output, as described in "Soft-Start Delay and Ramp Times" on page 14. If a soft-start delay period less than the minimum has been configured (using PMBus commands), the device will default to the minimum delay period. If a delay period greater than the minimum is configured, the device will wait for the configured delay period prior to starting to ramp its output.

After the delay period has expired, the output will begin to ramp towards its target voltage according to the pre-configured soft-start ramp time that has been set using the SS pin. It should be noted that if the EN pin is tied to VDD, the device will still require approximately 5ms to 10ms before the output can begin its ramp-up as described in Table 5.

TABLE 5. ZL6105 START-UP SEQUENCE

STEP #	STEP NAME	DESCRIPTION	TIME DURATION
1	Power Applied	Input voltage is applied to the ZL6105's VDD pin	Depends on input supply ramp time
2	Internal Memory Check	The device will check for values stored in its internal memory. This step is also performed after a Restore command.	Approximately 5ms to 10ms (device will ignore an enable signal or PMBus traffic during this period)
3	Multi-mode Pin Check	The device loads values configured by the multi-mode pins.	
4	Device Ready	The device is ready to accept an enable signal.	
5	Pre-ramp Delay	The device requires a minimum delay period following an enable signal and prior to ramping its output, as described in "Soft-Start Delay and Ramp Times" on page 14.	–

Soft-Start Delay and Ramp Times

It may be necessary to set a delay from when an enable signal is received until the output voltage starts to ramp to its target value. In addition, the designer may wish to precisely set the time required for V_{OUT} to ramp to its target value after the delay period has expired. These features may be used as part of an overall inrush current management strategy or to precisely control how fast a load IC is turned on. The ZL6105 gives the system designer several options for precisely and independently controlling both the delay and ramp time periods.

The soft-start delay period begins when the EN pin is asserted and ends when the delay time expires. The soft-start delay period is set using the SS pin.

The soft-start ramp timer enables a precisely controlled ramp to the nominal V_{OUT} value that begins once the delay period has expired. The ramp-up is guaranteed monotonic and its slope may be precisely set using the SS pin.

The soft start delay and ramp times can be set to standard values according to Table 6.

TABLE 6. SOFT-START PIN-STRAP SETTINGS

SS PIN	DELAY TIME (ms)	RAMP TIME (ms)
LOW	5	2
OPEN	5	5
HIGH	10	10

If the desired soft-start delay and ramp times are not one of the values listed in Table 6, the times can be set to a custom value by connecting a resistor from the SS pin to SGND using the appropriate resistor value from Table 7. The value of this resistor is measured upon start-up or Restore and will not change if the resistor is varied after power has been applied to the ZL6105.

The soft-start delay and ramp times can also be set to custom values via the I²C/SMBus interface. When the SS delay time is set to 0ms, the device will begin its ramp-up after the internal circuitry has initialized (approximately 2ms). When the soft-start ramp period is set to 0ms, the output will ramp up as quickly as the output load capacitance and loop settings will allow. It is generally recommended to set the soft-start ramp to a value greater than 500 μ s to prevent inadvertent fault conditions due to excessive in-rush current.

The ZL6105 has a minimum TON_DELAY requirement that is a function of the operating mode. Table 8 shows the different mode configurations and the minimum TON_DELAY required for each mode. Current sharing is configured with the ISHARE_CONFIG PMBus command, Auto compensation is configured with the AUTO_COMP_CONFIG command, and Standby Mode is configured as Low Power with the USER_CONFIG command. See Application Note AN2033 for details.

TABLE 7. SS RESISTOR SETTINGS

R _{SS} (k Ω)	DELAY TIME (ms)	RAMP TIME (ms)
13.3	5	2
14.7		5
16.2		10
17.8		20
19.6	10	2
21.5		5
23.7		10
26.1		20
28.7	15	2
31.6		5
34.8		10
38.3		20
42.2	20	2
46.4		5
51.1		10
56.2		20
61.9	30	2
68.1		5
75		10
82.5		20

TABLE 8. MINIMUM TON DELAY vs OPERATING MODE

Current Sharing	AutoComp	Low-Power Standby	Min. TON_DELAY (ms)
X	Disabled	False	5
Disabled	Enabled	False	5
Disabled	X	True	10
Enabled	Disabled	True	15
Enabled	Enabled	X	15

Power-Good

The ZL6105 provides a Power-Good (PG) signal that indicates the output voltage is within a specified tolerance of its target level and no fault condition exists. By default, the PG pin will assert if the output is within -10% of the target voltage. These limits and the polarity of the pin may be changed via the I²C/SMBus interface. See Application Note AN2033 for details.

A PG delay period is defined as the time from when all conditions within the ZL6105 for asserting PG are met to when the PG pin is actually asserted. This feature is commonly used instead of using an external reset controller to control external digital logic. By default, the ZL6105 PG delay is set equal to the soft-start ramp time setting. Therefore, if the soft-start ramp time is set to 10ms, the PG delay will be set to 10ms. The PG delay may be set independently of the soft-start ramp using the I²C/SMBus as described in Application Note AN2033.

If Auto Comp is enabled, the PG timing is further controlled by the PG Assert parameter, as described in “Loop Compensation” on page 21.

Switching Frequency and PLL

The ZL6105 incorporates an internal phase-locked loop (PLL) to clock the internal circuitry. The PLL can be driven by an external clock source connected to the SYNC pin. When using the internal oscillator, the SYNC pin can be configured as a clock source for other Zilker Labs devices.

The SYNC pin is a unique pin that can perform multiple functions depending on how it is configured. The CFG1 pin is used to select the operating mode of the SYNC pin as shown in Table 9. Figure 13 illustrates the typical connections for each mode.

TABLE 9. SYNC PIN FUNCTION SELECTION

CFG1 PIN	SYNC PIN FUNCTION
LOW	SYNC is configured as an input
OPEN	Auto Detect mode
HIGH	SYNC is configured as an output $f_{SW} = 400\text{kHz}$

CONFIGURATION A: SYNC OUTPUT

When the SYNC pin is configured as an output (CFG1 pin is tied HIGH), the device will run from its internal oscillator and will drive the resulting internal oscillator signal (preset to 400kHz) onto the SYNC pin so other devices can be synchronized to it. The SYNC pin will not be checked for an incoming clock signal while in this mode.

CONFIGURATION B: SYNC INPUT

When the SYNC pin is configured as an input (CFG1 pin is tied LOW) and the device is in Monitor Mode or self-enabled (EN tied to V25 or ON_OFF_CONFIG[4] = 0), the device will check for a clock signal on the SYNC pin immediately after power-up. In this case, the incoming clock signal must be in the range of 200kHz to 1.4MHz and must be stable within 10 μ s after V25 rises above 2.25V. When the SYNC pin is configured as an input (CFG1 pin is tied LOW) and the device is in Low Power Mode, the device will check for a clock signal on the SYNC pin immediately after EN goes true. In this case, the incoming clock signal must be in range and stable before EN goes true. The ZL6105's oscillator will then synchronize with the rising edge of the external clock.

The incoming clock signal must be in the range of 200kHz to 1.4MHz and must be stable when the enable pin is asserted. The clock signal must also exhibit the necessary performance requirements (see “Electrical Specifications” on page 8). In the event of a loss of the external clock signal, the output voltage may show transient over/undershoot.

If this happens, the ZL6105 will automatically switch to its internal oscillator and switch at a frequency close to the previous incoming frequency.

CONFIGURATION C: SYNC AUTO DETECT

When the SYNC pin is configured in auto detect mode (CFG1 pin is left OPEN) and the device is in Monitor Mode or self-enabled (EN tied to V25 or ON_OFF_CONFIG[4] = 0), the device will check for a clock signal on the SYNC pin immediately after power-up. In this case, the incoming clock signal must be in the range of 200kHz to 1.4MHz and must be stable within 10 μ s after V25 rises above 2.25V. When the SYNC pin is configured in auto detect mode (CFG1 pin is left OPEN) and the device is in Low Power Mode, the device will check for a clock signal on the SYNC pin immediately after EN goes true. In this case, the incoming clock signal must be in range and stable before EN goes true.

If a clock signal is present, the ZL6105's oscillator will then synchronize with the rising edge of the external clock. Refer to “Configuration B: SYNC INPUT” in the preceding section.

If no incoming clock signal is present, the ZL6105 will configure the switching frequency according to the state of the SYNC pin as listed in Table 10. In SYNC AutoDetect mode, the ZL6105 will only read the SYNC pin connection during the first start-up sequence; changes to SYNC pin connections will not affect f_{SW} until the power (VDD) is cycled off and on.

TABLE 10. SWITCHING FREQUENCY PIN-STRAP SETTINGS

SYNC PIN	FREQUENCY
LOW	200kHz
OPEN	400kHz
HIGH	1MHz
Resistor	See Table 11

If the user wishes to run the ZL6105 at a frequency not listed in Figure 10, the switching frequency can be set using an external resistor, R_{SYNC} , connected between SYNC and SGND using Table 11.

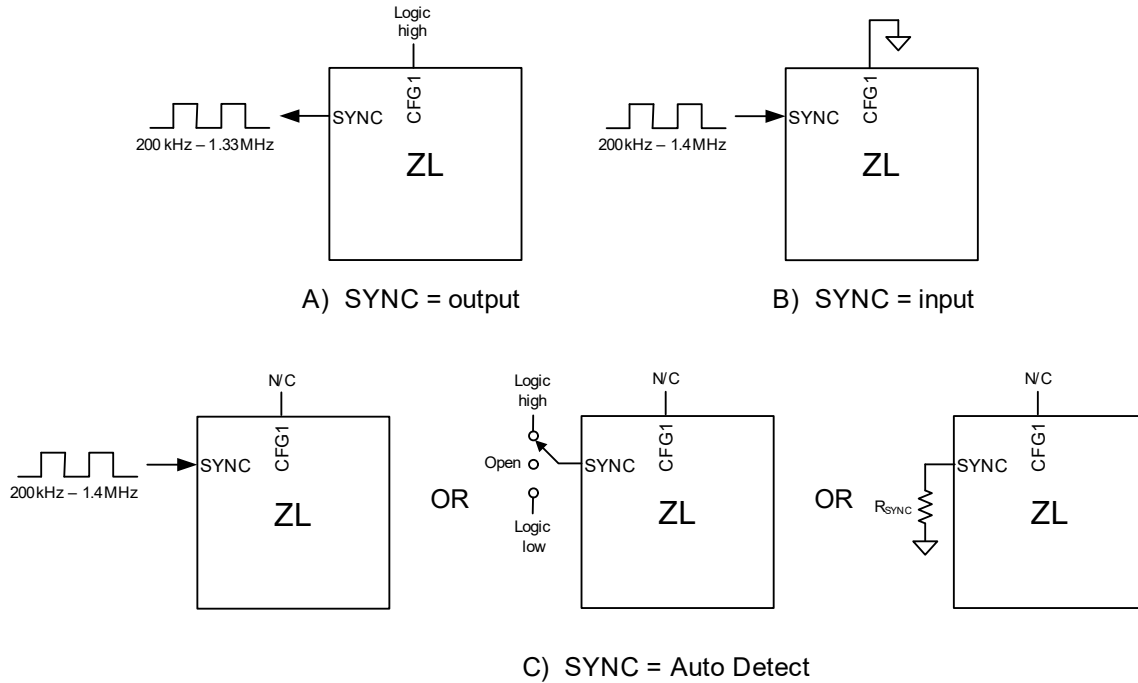

FIGURE 10. SYNC PIN CONFIGURATIONS

TABLE 11. SWITCHING FREQUENCY RESISTOR SETTINGS

R _{SYNC} (kΩ)	f _{SW} (kHz)	R _{SYNC} (kΩ)	f _{SW} (kHz)
10	200	26.1	533
11	222	28.7	571
12.1	242	31.6	615
13.3	267	34.8	727
14.7	296	38.3	800
16.2	320	46.4	889
17.8	364	51.1	1000
19.6	400	56.2	1143
21.5	421	68.1	1333
23.7	471		

The switching frequency can also be set to any value between 200kHz and 1.33MHz using the I²C/SMBus interface. The available frequencies below 1.4MHz are defined by $f_{SW} = 8\text{MHz}/N$, where the whole number N is $6 \leq N \leq 40$. See Application Note AN2033 for details.

If a value other than $f_{SW} = 8\text{MHz}/N$ is entered using a PMBus command, the internal circuitry will select the valid switching frequency value that is closest to the entered value. For example, if 810kHz is entered, the device will select 800kHz (N = 10).

When multiple Zilker Labs devices are used together, connecting the SYNC pins together will force all devices to synchronize with each other. The CFG1 pin of one device must set its SYNC pin as an output and the remaining devices must have their SYNC pins set as Auto Detect.

Note: The switching frequency read back using the appropriate PMBus command will differ slightly from the selected values in Table 11. The difference is due to hardware quantization.

Power Train Component Selection

The ZL6105 is a synchronous buck converter that uses external MOSFETs, inductor and capacitors to perform the power conversion process. The proper selection of the external components is critical for optimized performance.

To select the appropriate external components for the desired performance goals, the power supply requirements listed in Table 12 must be known.

TABLE 12. POWER SUPPLY REQUIREMENTS

PARAMETER	RANGE	EXAMPLE VALUE
Input Voltage (V _{IN})	3V to 14V	12V
Output Voltage (V _{OUT})	0.6V to 5.0V	1.2V
Output Current (I _{OUT})	0A to ~25A	20A
Output Voltage Ripple (V _{ORIP})	<3% of V _{OUT}	1% of V _{OUT}
Output Load Step (I _{OSTEP})	<I _O	50% of I _O
Output Load Step Rate	-	10A/μs
Output Deviation Due to Load Step	-	±50mV
Maximum PCB Temp.	+120 °C	+85 °C
Desired Efficiency	-	85%
Other Considerations	Various	Optimize for small size

DESIGN GOAL TRADE-OFFS

The design of the buck power stage requires several compromises among size, efficiency, and cost. The inductor core loss increases with frequency, so there is a trade-off between a small output filter made possible by a higher switching frequency and getting better power supply efficiency. Size can be decreased

by increasing the switching frequency at the expense of efficiency. Cost can be minimized by using through-hole inductors and capacitors; however these components are physically large.

To start the design, select a switching frequency based on Table 13. This frequency is a starting point and may be adjusted as the design progresses.

TABLE 13. CIRCUIT DESIGN CONSIDERATIONS

FREQUENCY RANGE	EFFICIENCY	CIRCUIT SIZE
200kHz to 400kHz	Highest	Larger
400kHz to 800kHz	Moderate	Smaller
800kHz to 1.4MHz	Lower	Smallest

INDUCTOR SELECTION

The output inductor selection process must include several trade-offs. A high inductance value will result in a low ripple current ($I_{O(P-P)}$), which will reduce output capacitance and produce a low output ripple voltage, but may also compromise output transient load performance. Therefore, a balance must be struck between output ripple and optimal load transient performance. A good starting point is to select the output inductor ripple equal to the expected load transient step magnitude (I_{OSTEP}) as shown in Equation 5:

$$I_{opp} = I_{ostep} \quad (\text{EQ. 5})$$

Now the output inductance can be calculated using Equation 6:

$$L_{OUT} = \frac{V_{OUT} \times \left(1 - \frac{V_{OUT}}{V_{INM}}\right)}{f_{sw} \times I_{opp}} \quad (\text{EQ. 6})$$

where V_{INM} is the maximum input voltage.

The average inductor current is equal to the maximum output current. The peak inductor current (I_{Lpk}) is calculated using Equation 7:

$$I_{Lpk} = I_{OUT} + \frac{I_{opp}}{2} \quad (\text{EQ. 7})$$

where I_{OUT} is the maximum output current.

Select an inductor rated for the average DC current with a peak current rating above the peak current computed in Equation 7.

In overcurrent or short-circuit conditions, the inductor may have currents greater than 2x the normal maximum rated output current. It is desirable to use an inductor that still provides some inductance to protect the load and the MOSFETs from damaging currents in this situation.

Once an inductor is selected, the DCR and core losses in the inductor are calculated as in Equation 8. Use the DCR specified in the inductor manufacturer's datasheet.

$$P_{LDCR} = DCR \times I_{Lrms}^2 \quad (\text{EQ. 8})$$

I_{Lrms} is given by Equation 9.

$$I_{Lrms} = \sqrt{I_{OUT}^2 + \frac{(I_{opp})^2}{12}} \quad (\text{EQ. 9})$$

where I_{OUT} is the maximum output current. Next, calculate the core loss of the selected inductor. Since this calculation is specific to each inductor and manufacturer, refer to the chosen inductor datasheet. Add the core loss and the ESR loss and compare the total loss to the maximum power dissipation recommendation in the inductor datasheet.

OUTPUT CAPACITOR SELECTION

Several trade-offs must also be considered when selecting an output capacitor. Low ESR values are needed to have a small output deviation during transient load steps (V_{OSAG}) and low output voltage ripple (V_{ORIP}). However, capacitors with low ESR, such as semi-stable (X5R and X7R) dielectric ceramic capacitors, also have relatively low capacitance values. Many designs can use a combination of high capacitance devices and low ESR devices in parallel.

For high ripple currents, a low capacitance value can cause a significant amount of output voltage ripple. Likewise, in high transient load steps, a relatively large amount of capacitance is needed to minimize the output voltage deviation while the inductor current ramps up or down to the new steady state output current value.

As a starting point, apportion one-half of the output ripple voltage to the capacitor ESR and the other half to capacitance, as shown in the Equations 10 and 11:

$$C_{OUT} = \frac{I_{opp}}{8 \times f_{sw} \times \frac{V_{orip}}{2}} \quad (\text{EQ. 10})$$

$$ESR = \frac{V_{orip}}{2 \times I_{opp}} \quad (\text{EQ. 11})$$

Use these values to make an initial capacitor selection, using a single capacitor or several capacitors in parallel.

After a capacitor has been selected, the resulting output voltage ripple can be calculated using Equation 12:

$$V_{orip} = I_{opp} \times ESR + \frac{I_{opp}}{8 \times f_{sw} \times C_{OUT}} \quad (\text{EQ. 12})$$

Because each part of this equation was made to be less than or equal to half of the allowed output ripple voltage, the V_{ORIP} should be less than the desired maximum output ripple.

INPUT CAPACITOR

It is highly recommended that dedicated input capacitors be used in any point-of-load design, even when the supply is powered from a heavily filtered 5V or 12V "bulk" supply from an off-line power supply. This is because of the high RMS ripple current that is drawn by the buck converter topology. This ripple (I_{CINrms}) can be determined from Equation 13:

$$I_{CINrms} = I_{OUT} \times \sqrt{D \times (1 - D)} \quad (\text{EQ. 13})$$

Without capacitive filtering near the power supply circuit, this current would flow through the supply bus and return planes, coupling noise into other system circuitry. The input capacitors should be rated at 1.2x the ripple current calculated in Equation 13 to avoid overheating of the capacitors due to the high ripple current, which can cause premature failure. Ceramic capacitors with X7R or X5R dielectric with low ESR and 1.1x the maximum expected input voltage are recommended.

BOOTSTRAP CAPACITOR SELECTION

The high-side driver boost circuit utilizes an external Schottky diode (D_B) and an external bootstrap capacitor (C_B) to supply sufficient gate drive for the high-side MOSFET driver. D_B should be a 20mA, 30V Schottky diode or equivalent device and C_B should be a 1 μ F ceramic type rated for at least 6.3V.

QL SELECTION

The bottom MOSFET should be selected primarily based on the device's $r_{DS(ON)}$ and secondarily based on its gate charge. To choose QL, use Equation 14 and allow 2% to 5% of the output power to be dissipated in the $r_{DS(ON)}$ of QL (lower output voltages and higher step-down ratios will be closer to 5%):

$$P_{QL} = 0.05 \times V_{OUT} \times I_{OUT} \quad (\text{EQ. 14})$$

Calculate the RMS current in QL as shown in Equation 15:

$$I_{botrms} = I_{Lrms} \times \sqrt{1-D} \quad (\text{EQ. 15})$$

Calculate the desired maximum $r_{DS(ON)}$ as shown in Equation 16:

$$R_{DS(ON)} = \frac{P_{QL}}{(I_{botrms})^2} \quad (\text{EQ. 16})$$

Note that the $r_{DS(ON)}$ given in the manufacturer's datasheet is measured at +25°C. The actual $r_{DS(ON)}$ in the end-use application will be much higher. For example, a Vishay Si7114 MOSFET with a junction temperature of +125°C has an $r_{DS(ON)}$ that is 1.4x higher than the value at +25°C. Select a candidate MOSFET, and calculate the required gate drive current as shown in Equation 17:

$$I_g = f_{SW} \times Q_g \quad (\text{EQ. 17})$$

Keep in mind that the total allowed gate drive current for both QH and QL is 80mA.

MOSFETs with lower $r_{DS(ON)}$ tend to have higher gate charge requirements, which increases the current and resulting power required to turn them on and off. Since the MOSFET gate drive circuits are integrated in the ZL6105, this power is dissipated in the ZL6105 according to the Equation 18:

$$P_{QL} = f_{sw} \times Q_g \times V_{INM} \quad (\text{EQ. 18})$$

QH SELECTION

In addition to the $r_{DS(ON)}$ loss and gate charge loss, QH also has switching loss. The procedure to select QH is similar to the procedure for QL. First, assign 2% to 5% of the output power to be dissipated in the $r_{DS(ON)}$ of QH using Equation 18 for QL. As was done with QL, calculate the RMS current as shown in Equation 19:

$$I_{toprms} = I_{Lrms} \times \sqrt{D} \quad (\text{EQ. 19})$$

Calculate a starting $r_{DS(ON)}$ as shown in Equation 20. This equation uses 5% as an example:

$$P_{QH} = 0.05 \times V_{OUT} \times I_{OUT} \quad (\text{EQ. 20})$$

$$R_{DS(ON)} = \frac{P_{QH}}{(I_{toprms})^2} \quad (\text{EQ. 21})$$

Select a MOSFET and calculate the resulting gate drive current. Verify that the combined gate drive current from QL and QH does not exceed 80mA.

Next, calculate the switching time using Equation 22:

$$t_{SW} = \frac{Q_g}{I_{gdr}} \quad (\text{EQ. 22})$$

where Q_g is the gate charge of the selected QH and I_{gdr} is the peak gate drive current available from the ZL6105.

Although the ZL6105 has a typical gate drive current of 3A, use the minimum guaranteed current of 2A for a conservative design. Using the calculated switching time, calculate the switching power loss in QH using Equation 23:

$$P_{swtop} = V_{INM} \times t_{sw} \times I_{OUT} \times f_{sw} \quad (\text{EQ. 23})$$

The total power dissipated by QH is given by Equation 24:

$$P_{QHtot} = P_{QH} + P_{swtop} \quad (\text{EQ. 24})$$

MOSFET THERMAL CHECK

Once the power dissipations for QH and QL have been calculated, the MOSFETs junction temperature can be estimated. Using the junction-to-case thermal resistance (R_{th}) given in the MOSFET manufacturer's datasheet and the expected maximum printed circuit board temperature, calculate the junction temperature as shown in Equation 25:

$$T_{jmax} = T_{pcb} + (P_Q \times R_{th}) \quad (\text{EQ. 25})$$

CURRENT SENSING COMPONENTS

Once the current sense method has been selected (Refer to "Current Limit Threshold Selection" on page 19"), the components are selected as indicated in the following.

When using the inductor DCR sensing method, the user must also select an R/C network comprised of R1 and CL (see Figure 11).

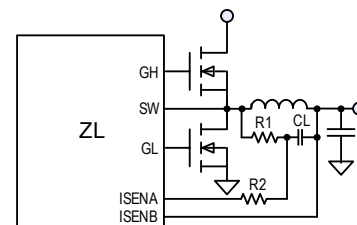

FIGURE 11. DCR CURRENT SENSING

For the voltage across C_L to reflect the voltage across the DCR of the inductor, the time constant of the inductor must match the time constant of the RC network as shown in Equation 26:

$$\tau_{RC} = \tau_{L/DCR} \tag{EQ. 26}$$

$$R_1 \cdot C_L = \frac{L}{DCR}$$

For L, use the average of the nominal value and the minimum value. Include the effects of tolerance, DC Bias and switching frequency on the inductance when determining the minimum value of L. Use the typical value for DCR.

The value of R_1 should be as small as feasible and no greater than $5k\Omega$ for best signal-to-noise ratio. The designer should make sure the resistor package size is appropriate for the power dissipated and include this loss in efficiency calculations. In calculating the minimum value of R_1 , the average voltage across C_L (which is the average $I_{OUT} \cdot DCR$ product) is small and can be neglected. Therefore, the minimum value of R_1 may be approximated by Equation 27:

$$R_{1-min} = \frac{D(V_{IN-max} - V_{OUT})^2 + (1 - D) \cdot V_{OUT}^2}{P_{R1pkg-max} \cdot \delta_P} \tag{EQ. 27}$$

where $P_{R1pkg-max}$ is the maximum power dissipation specification for the resistor package and δ_P is the derating factor for the same parameter (eg: $P_{R1pkg-max} = 0.0625W$ for 0603 package, $\delta_P = 50\%$ @ $+85^\circ C$). Once R_{1-min} has been calculated, solve for the maximum value of C_L from Equation 28:

$$C_{L-max} = \frac{L}{R_{1-min} \cdot DCR} \tag{EQ. 28}$$

Next, choose the next-lowest readily available value (eg: For $C_{L-max} = 1.86\mu F$, $C_L = 1.5\mu F$ is a good choice). Then substitute the chosen value into the same equation and re-calculate the value of R_1 . Choose the 1% resistor standard value closest to this re-calculated value of R_1 . The error due to the mismatch of the two time constants is as shown in Equation 29.

$$\epsilon_\tau = \left(1 - \frac{R_1 \cdot C_L \cdot DCR}{L_{avg}} \right) \cdot 100\% \tag{EQ. 29}$$

The value of R_2 should be $2k\Omega$.

For the $r_{DS(ON)}$ current sensing method, the external low side MOSFET will act as the sensing element as indicated in Figure 12.

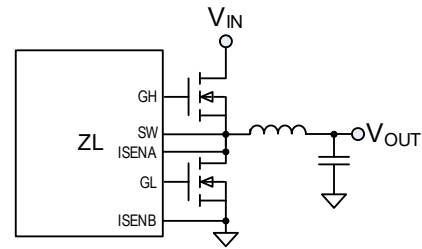

MOSFET $R_{DS(ON)}$ Sensing

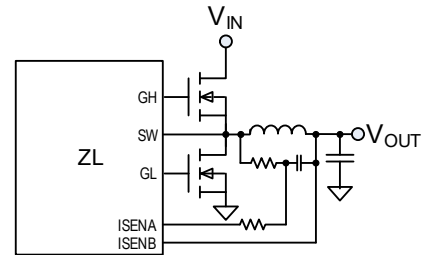

Inductor DCR Sensing
(V_{OUT} must be less than 4.0 V)

FIGURE 12. CURRENT SENSING METHODS

Current Limit Threshold Selection

It is recommended that the user include a current limiting mechanism in their design to protect the power supply from damage and prevent excessive current from being drawn from the input supply in the event that the output is shorted to ground or an overload condition is imposed on the output. Current limiting is accomplished by sensing the current through the circuit during a portion of the duty cycle.

Output current sensing can be accomplished by measuring the voltage across a series resistive sensing element according to Equation 30:

$$V_{LIM} = I_{LIM} \times R_{SENSE} \tag{EQ. 30}$$

Where:

I_{LIM} is the desired maximum current that should flow in the circuit.

R_{SENSE} is the resistance of the sensing element.

V_{LIM} is the voltage across the sensing element at the point the circuit should start limiting the output current.

The ZL6105 supports “lossless” current sensing by measuring the voltage across a resistive element that is already present in the circuit. This eliminates additional efficiency losses incurred by devices that must use an additional series resistance in the circuit.

To set the current limit threshold, the user must first select a current sensing method. The ZL6105 incorporates two methods for current sensing, synchronous MOSFET $r_{DS(ON)}$ sensing and inductor DC resistance (DCR) sensing; Figure 12 shows a simplified schematic for each method. The current sensing method can be selected via the I²C/SMBus interface. Please refer to Application Note AN2033 for details.

In addition to selecting the current sensing method, the ZL6105 gives the power supply designer several choices for the fault response during over or under current condition. The user can select the number of violations allowed before declaring fault, a blanking time and the action taken when a fault is detected.

The blanking time represents the time when no current measurement is taken. This is to avoid taking a reading just after a current load step (less accurate due to potential ringing). It is a configurable parameter.

Once the sensing method has been selected, the user must select the voltage threshold (V_{LIM}), the desired current limit threshold, and the resistance of the sensing element.

The current limit threshold voltage can be selected by simply connecting the ILIM pin as shown in Table 14. The ground-referenced sensing method is being used in this mode. Note that IOUT_CAL_GAIN is set to $2m\Omega$ for RDS sensing and set to $1m\Omega$ for DCR sensing by default.

TABLE 14. CURRENT LIMIT THRESHOLD VOLTAGE PIN-STRAP SETTINGS

ILIM Pin	$R_{DS} V_{LIM}$ (mV)	DCR V_{LIM} (mV)
LOW	50	25
OPEN	60	30
HIGH	70	35

The threshold voltage can also be selected in 5mV increments by connecting a resistor, R_{LIM} , between the ILIM pin and ground according to Table 15. This method is preferred if the user does not desire to use or does not have access to the I²C/SMBus interface and the desired threshold value is contained in Table 15.

TABLE 15. CURRENT LIMIT THRESHOLD VOLTAGE RESISTOR SETTINGS

R_{LIM} (k Ω)	$R_{DS} V_{LIM}$ (mV)	DCR V_{LIM} (mV)
10	0	0
11	5	2.5
12.1	10	5
13.3	15	7.5
14.7	20	10
16.2	25	12.5
17.8	30	15
19.6	35	17.5
21.5	40	20
23.7	45	22.5
26.1	50	25
28.7	55	27.5
31.6	60	30
34.8	65	32.5
38.3	70	35
42.2	75	37.5
46.4	80	40
51.1	85	42.5
56.2	90	45
61.9	95	47.5
68.1	100	50
75	105	52.5
82.5	110	55
90.9	115	57.5
100	120	60

The current limit threshold can also be set to a custom value via the I²C/SMBus interface. Please refer to Application Note AN2033 for further details.

Loop Compensation

The ZL6105 operates as a voltage-mode synchronous buck controller with a fixed frequency PWM scheme. Although the ZL6105 uses a digital control loop, it operates much like a traditional analog PWM controller. Figure 13 is a simplified block diagram of the ZL6105 control loop, which differs from an analog control loop only by the constants in the PWM and compensation blocks. As in the analog controller case, the compensation block compares the output voltage to the desired voltage reference and compensates to keep the loop stable. The resulting integrated error signal is used to drive the PWM logic, converting the error signal to a duty cycle to drive the external MOSFETS.

The ZL6105 has an auto compensation feature that measures the characteristics of the power train and calculates the proper tap coefficients. Auto compensation is configured using the FC0 and FC1 pins as shown in Table 16 and Table 17.

When auto compensation is enabled, the routine can be set to execute one time after ramp or periodically while regulating. Note that the Auto Compensation feature requires a minimum TON_DELAY as described in “Soft-Start Delay and Ramp Times” on page 14.

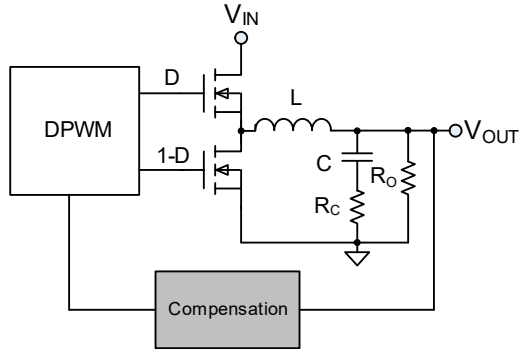

FIGURE 13. CONTROL LOOP BLOCK DIAGRAM

If the device is configured to store auto comp values, the calculated compensation values will be saved in the Auto Comp Store and may be read back through the PID_TAPS command. If repeat mode is enabled, the first Auto Comp results after the first ramp will be stored; the values calculated periodically are not stored in the Auto Comp Store. When compensation values are saved in the Auto Comp Store, the device will use those compensation values on subsequent ramps. In repeat mode, the latest Auto Comp results will always be used during operation. Stored Auto Comp results can only be cleared by disabling Auto Comp Store, which is not permitted while the output is enabled. However, sending the AUTOCOMP_CONTROL command while enabled in Store mode will cause the next results to be stored, overwriting previously stored values. If auto compensation is disabled, the device will use the compensation parameters that are stored in the DEFAULT_STORE or USER_STORE.

If the PG Assert parameter is set to "Use PG Delay," PG will be asserted according to the POWER_GOOD_DELAY command, after which Auto Comp will begin. When Auto Comp is enabled, the user must not program a Power-Good Delay that will expire before the ramp is finished. If PG Assert is set to "After Auto Comp," PG will be asserted immediately after the first Auto Comp cycle completes (POWER_GOOD_DELAY will be ignored).

The Auto Comp Gain control scales the Auto Comp results to allow a trade-off between transient response and steady-state duty cycle jitter. A setting of 100% will provide the fastest transient response while a setting of 10% will produce the lowest jitter.

Note that if Auto Comp is enabled, for best results Vin must be stable before Auto Comp begins, as shown in Equation 31.

$$\frac{\Delta V_{in}}{V_{inNom}} (\text{in}\%) \leq \frac{100\%}{1 + \frac{256 \cdot V_{out}}{V_{inNom}}} \quad (\text{EQ. 31})$$

The auto compensation function can also be configured via the AUTO_COMP_CONFIG command and controlled using the

AUTO_COMP_CONTROL command over the I²C/SMBus interface. Please refer to Application Note AN2033 for further details.

TABLE 16. FC0 PIN-STRAP SETTINGS

FC0 PIN	STORE VALUES	SINGLE/REPEAT	PG ASSERT
LOW	Auto Comp Disabled		
OPEN	Not Stored	Single	After Auto Comp
HIGH	Store in Flash	Single	After Auto Comp
10kΩ	Not Stored	Single	After Auto Comp
11kΩ	Store in Flash		
12.1kΩ	Not Stored	Repeat ~1 sec	After Auto Comp
13.3kΩ	Store in Flash		
14.7kΩ	Not Stored	Single	After PG Delay
16.2kΩ	Store in Flash		
17.8kΩ	Not Stored	Repeat ~1 sec	After PG Delay
19.6kΩ	Store in Flash		
21.5kΩ	Not Stored	Single	After Auto Comp
23.7kΩ	Store in Flash		
26.1kΩ	Not Stored	Repeat ~1 min	After Auto Comp
28.7kΩ	Store in Flash		
31.6kΩ	Not Stored	Single	After PG Delay
34.8kΩ	Store in Flash		
38.3kΩ	Not Stored	Repeat ~1 min	After PG Delay
42.2kΩ	Store in Flash		

TABLE 17. FC1 PIN-STRAP SETTINGS

FC1 PIN	AUTO COMP GAIN
LOW	100%
OPEN	50%
HIGH	30%
10kΩ	10%
11kΩ	20%
12.1kΩ	30%
13.3kΩ	40%
14.7kΩ	50%
16.2kΩ	60%
17.8kΩ	70%
19.6kΩ	80%
21.5kΩ	90%
23.7kΩ	100%

Non-linear Response (NLR) Settings

The ZL6105 incorporates a non-linear response (NLR) loop that decreases the response time and the output voltage deviation in the event of a sudden output load current step. The NLR loop incorporates a secondary error signal processing path that bypasses the primary error loop when the output begins to transition outside of the standard regulation limits. This scheme results in a higher equivalent loop bandwidth than what is possible using a traditional linear loop.

When a load current step function imposed on the output causes the output voltage to drop below the lower regulation limit, the NLR circuitry will force a positive correction signal that will turn on the upper MOSFET and quickly force the output to increase. Conversely, a negative load step (i.e. removing a large load current) will cause the NLR circuitry to force a negative correction signal that will turn on the lower MOSFET and quickly force the output to decrease.

NLR can be configured using resistor pin-straps as follows:

- CFG0 disables NLR or enables NLR inner thresholds to 1.5%, 2% or 3% (see Table 29).
- CFG1 sets NLR inner thresholds timeout and blanking to 1 and 4 or 2 and 8 (see Table 26).

Please refer to Application Note AN2032 for more details regarding NLR settings.

Efficiency Optimized Driver Dead-time Control

The ZL6105 utilizes a closed loop algorithm to optimize the dead-time applied between the gate drive signals for the top and bottom FETs. In a synchronous buck converter, the MOSFET drive circuitry must be designed such that the top and bottom MOSFETs are never in the conducting state at the same time. Potentially damaging currents flow in the circuit if both top and

bottom MOSFETs are simultaneously on for periods of time exceeding a few nanoseconds. Conversely, long periods of time in which both MOSFETs are off reduce overall circuit efficiency by allowing current to flow in their parasitic body diodes.

It is therefore advantageous to minimize this dead-time to provide optimum circuit efficiency. In the first order model of a buck converter, the duty cycle is determined by Equation 32:

$$D \approx \frac{V_{OUT}}{V_{IN}} \quad (\text{EQ. 32})$$

However, non-idealities exist that cause the real duty cycle to extend beyond the ideal. Dead-time is one of those non-idealities that can be manipulated to improve efficiency. The ZL6105 has an internal algorithm that constantly adjusts dead-time non-overlap to minimize duty cycle, thus maximizing efficiency. This circuit will null out dead-time differences due to component variation, temperature, and loading effects.

This algorithm is independent of application circuit parameters such as MOSFET type, gate driver delays, rise and fall times and circuit layout. In addition, it does not require drive or MOSFET voltage or current waveform measurements.

Adaptive Diode Emulation

Most power converters use synchronous rectification to optimize efficiency over a wide range of input and output conditions. However, at light loads the synchronous MOSFET will typically sink current and introduce additional energy losses associated with higher peak inductor currents, resulting in reduced efficiency. Adaptive diode emulation mode turns off the low-side FET gate drive at low load currents to prevent the inductor current from going negative, reducing the energy losses and increasing overall efficiency.

Note: the overall bandwidth of the device may be reduced when in diode emulation mode. It is recommended that diode emulation is disabled prior to applying significant load steps.

Power Management Functional Description

Input Undervoltage Lockout

The input undervoltage lockout (UVLO) prevents the ZL6105 from operating when the input falls below a preset threshold, indicating the input supply is out of its specified range. The UVLO threshold (V_{UVLO}) can be set between 2.85V and 16V using the UVLO pin. The simplest implementation is to connect the UVLO pin as shown in Table 18. If the UVLO pin is left unconnected, the UVLO threshold will default to 4.5V.

TABLE 18. UVLO THRESHOLD PIN-STRAP SETTINGS

UVLO PIN	UVLO THRESHOLD (V)
LOW	3
OPEN	4.5
HIGH	10.8

If the desired UVLO threshold is not one of the listed choices, the user can configure a threshold between 2.85V and 16V by connecting a resistor between the UVLO pin and SGND by selecting the appropriate resistor from Table 19.

TABLE 19. UVLO THRESHOLD RESISTOR SETTINGS

R _{UVLO} (kΩ)	UVLO (V)	R _{UVLO} (kΩ)	UVLO (V)
17.8	2.85	46.4	7.42
19.6	3.14	51.1	8.18
21.5	3.44	56.2	8.99
23.7	3.79	61.9	9.9
26.1	4.18	68.1	10.9
28.7	4.59	75	12
31.6	5.06	82.5	13.2
34.8	5.57	90.9	14.54
38.3	6.13	100	16
42.2	6.75		

The UVLO voltage can also be set to any value between 2.85V and 16V via the I²C/SMBus interface.

Once an input undervoltage fault condition occurs, the device can respond in a number of ways as follows:

1. Continue operating without interruption.
2. Continue operating for a given delay period, followed by shutdown if the fault still exists. The device will remain in shutdown until instructed to restart.
3. Initiate an immediate shutdown until the fault has been cleared. The user can select a specific number of retry attempts.

The default response from a UVLO fault is an immediate shutdown of the device. The device will continuously check for the presence of the fault condition. If the fault condition is no longer present, the ZL6105 will be re-enabled.

Please refer to Application Note AN2033 for details on how to configure the UVLO threshold or to select specific UVLO fault response options via the I²C/SMBus interface.

Output Overvoltage Protection

The ZL6105 offers an internal output overvoltage protection circuit that can be used to protect sensitive load circuitry from being subjected to a voltage higher than its prescribed limits. A hardware comparator is used to compare the actual output voltage (seen at the VSEN pin) to a threshold set to 15% higher than the target output voltage (the default setting). If the VSEN voltage exceeds this threshold, the PG pin will de-assert and the device can then respond in a number of ways as follows:

1. Initiate an immediate shutdown until the fault has been cleared. The user can select a specific number of retry attempts.
2. Turn off the high-side MOSFET and turn on the low-side MOSFET. The low-side MOSFET remains ON until the device attempts a restart.

The default response from an overvoltage fault is to immediately shut down. The device will continuously check for the presence of the fault condition, and when the fault condition no longer exists the device will be re-enabled.

For continuous overvoltage protection when operating from an external clock, the only allowed response is an immediate shutdown.

Please refer to Application Note AN2033 for details on how to select specific overvoltage fault response options via I²C/SMBus.

Output Pre-Bias Protection

An output pre-bias condition exists when an externally applied voltage is present on a power supply's output before the power supply's control IC is enabled. Certain applications require that the converter not be allowed to sink current during start up if a pre-bias condition exists at the output. The ZL6105 provides pre-bias protection by sampling the output voltage prior to initiating an output ramp.

If a pre-bias voltage lower than the target voltage exists after the pre-configured delay period has expired, the target voltage is set to match the existing pre-bias voltage and both drivers are enabled. The output voltage is then ramped to the final regulation value at the ramp rate set by the SS pin.

The actual time the output will take to ramp from the pre-bias voltage to the target voltage will vary depending on the pre-bias voltage but the total time elapsed from when the delay period expires and when the output reaches its target value will match the pre-configured ramp time. See Figure 14.

If a pre-bias voltage higher than the target voltage exists after the pre-configured delay period has expired, the target voltage is set to match the existing pre-bias voltage and both drivers are enabled with a PWM duty cycle that would ideally create the pre-bias voltage.

Once the pre-configured soft-start ramp period has expired, the PG pin will be asserted (assuming the pre-bias voltage is not higher than the overvoltage limit). The PWM will then adjust its duty cycle to match the original target voltage and the output will ramp down to the pre-configured output voltage.

If a pre-bias voltage higher than the overvoltage limit exists, the device will not initiate a turn-on sequence and will declare an overvoltage fault condition to exist. In this case, the device will respond based on the output overvoltage fault response method that has been selected. See "Output Overvoltage Protection" on page 23 for response options due to an overvoltage condition.

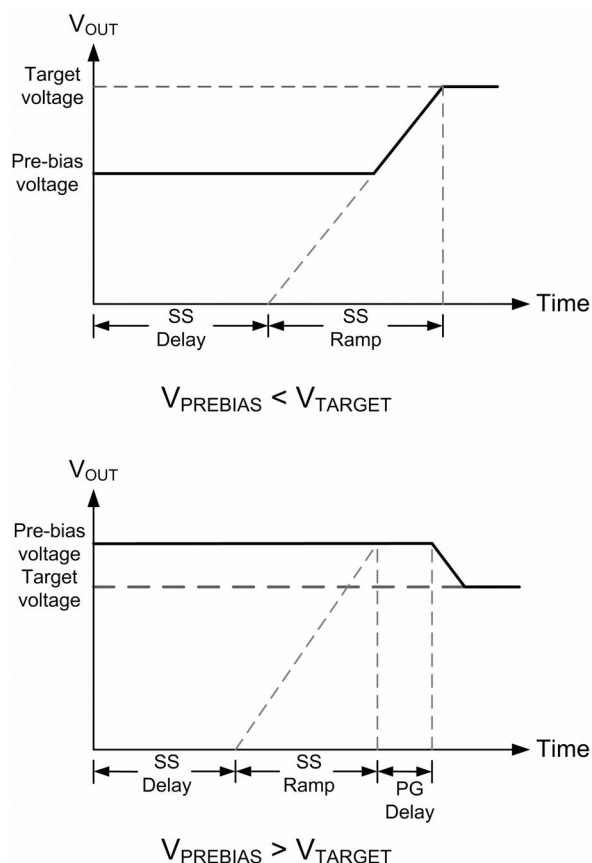

FIGURE 14. OUTPUT RESPONSES TO PRE-BIAS VOLTAGES

Output Overcurrent Protection

The ZL6105 can protect the power supply from damage if the output is shorted to ground or if an overload condition is imposed on the output. Once the current limit threshold has been selected (see “Current Limit Threshold Selection” on page 19), the user may determine the desired course of action in response to the fault condition. The following overcurrent protection response options are available:

1. Initiate a shutdown and attempt to restart an infinite number of times with a preset delay period between attempts.
2. Initiate a shutdown and attempt to restart a preset number of times with a preset delay period between attempts.
3. Continue operating for a given delay period, followed by shutdown if the fault still exists.
4. Continue operating through the fault (this could result in permanent damage to the power supply).
5. Initiate an immediate shutdown.

The default response from an overcurrent fault is an immediate shutdown of the device. The device will continuously check for the presence of the fault condition, and if the fault condition no longer exists the device will be re-enabled.

Please refer to Application Note AN2033 for details on how to select specific overcurrent fault response options via I²C/SMBus.

Thermal Overload Protection

The ZL6105 includes an on-chip thermal sensor that continuously measures the internal temperature of the die and shuts down the device when the temperature exceeds the preset limit. The default temperature limit is set to +125 °C in the factory, but the user may set the limit to a different value if desired. See Application Note AN2033 for details. Note that setting a higher thermal limit via the I²C/SMBus interface may result in permanent damage to the device. Once the device has been disabled due to an internal temperature fault, the user may select one of several fault response options as follows:

1. Initiate a shutdown and attempt to restart an infinite number of times with a preset delay period between attempts.
2. Initiate a shutdown and attempt to restart a preset number of times with a preset delay period between attempts.
3. Continue operating for a given delay period, followed by shutdown if the fault still exists.
4. Continue operating through the fault (this could result in permanent damage to the power supply).
5. Initiate an immediate shutdown.

If the user has configured the device to restart, the device will wait the preset delay period (if configured to do so) and will then check the device temperature. If the temperature has dropped below a threshold that is approximately +15 °C lower than the selected temperature fault limit, the device will attempt to restart. If the temperature still exceeds the fault limit the device will wait the preset delay period and retry again.

The default response from a temperature fault is an immediate shutdown of the device. The device will continuously check for the fault condition, and once the fault has cleared the ZL6105 will be re-enabled.

Please refer to Application Note AN2033 for details on how to select specific temperature fault response options via I²C/SMBus.

Voltage Tracking

Numerous high performance systems place stringent demands on the order in which the power supply voltages are turned on. This is particularly true when powering FPGAs, ASICs, and other advanced processor devices that require multiple supply voltages to power a single die. In most cases, the I/O interface operates at a higher voltage than the core and therefore the core supply voltage must not exceed the I/O supply voltage according to the manufacturers' specifications.

Voltage tracking protects these sensitive ICs by limiting the differential voltage between multiple power supplies during the power-up and power down sequence. The ZL6105 integrates a lossless tracking scheme that allows its output to track a voltage that is applied to the VTRK pin with no external components required. The VTRK pin is an analog input that, when tracking mode is enabled, configures the voltage applied to the VTRK pin to act as a reference for the device's output regulation.

The ZL6105 offers two modes of tracking as follows:

1. *Coincident*. This mode configures the ZL6105 to ramp its output voltage at the same rate as the voltage applied to the VTRK pin.

2. **Ratiometric.** This mode configures the ZL6105 to ramp its output voltage at a rate that is a percentage of the voltage applied to the VTRK pin. The default setting is 50%, but an external resistor string may be used to configure a different tracking ratio.

Figure 15 illustrates the typical connection and the two tracking modes.

The master ZL6105 device in a tracking group is defined as the device that has the highest target output voltage within the group. This master device will control the ramp rate of all tracking devices and is not configured for tracking mode. A delay of at least 10ms must be configured into the master device using the SS pin, and the user may also configure a specific ramp rate using the SS pin. Any device that is configured for tracking mode will ignore its soft-start delay and ramp time settings (SS pin) and its output will take on the turn-on/turn-off characteristics of the reference voltage present at the VTRK pin. All of the ENABLE pins in the tracking group must be connected together and driven by a single logic source. Tracking is configured via the I²C/SMBus interface by using the TRACK_CONFIG PMBus command. Please refer to Application Note AN2033 for more information on configuring tracking mode using PMBus.

When a current sharing rail is tracking, the on-delay time of the voltage being tracked must not exceed the on-delay of the tracking rail by 5ms.

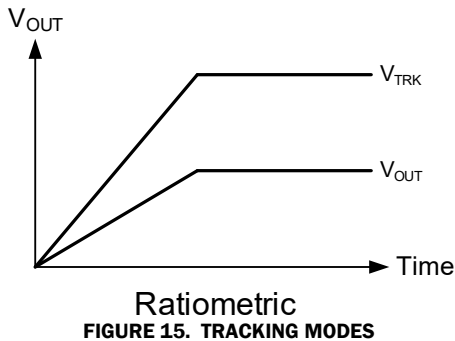
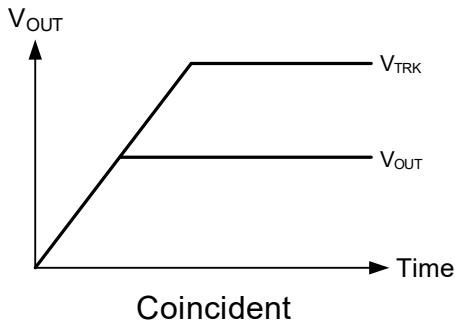
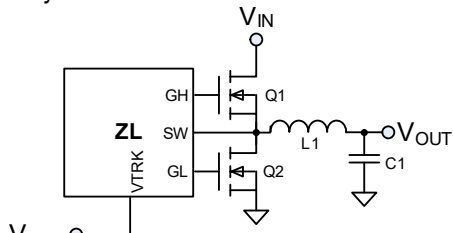

FIGURE 15. TRACKING MODES

TABLE 20. TRACKING RESISTOR SETTINGS

R _{SS} (kΩ)	TRACK RATIO (%)	UPPER TRACK LIMIT	RAMP-UP/DOWN BEHAVIOR
90.9	100	Limited by target	Output does not decrease before PG
100			Output always follows VTRK
110		Limited by VTRK	Output does not decrease before PG
121	Output always follows VTRK		
133	50	Limited by target	Output does not decrease before PG
147			Output always follows VTRK
162		Limited by VTRK	Output does not decrease before PG
178			Output always follows VTRK

Voltage Margining

The ZL6105 offers a simple means to vary its output higher or lower than its nominal voltage setting in order to determine whether the load device is capable of operating over its specified supply voltage range. The MGN command is set by driving the MGN pin or through the I²C/SMBus interface. The MGN pin is a tri-level input that is continuously monitored and can be driven directly by a processor I/O pin or other logic-level output.

The ZL6105's output will be forced higher than its nominal set point when the MGN command is set HIGH, and the output will be forced lower than its nominal set point when the MGN command is set LOW. Default margin limits of V_{NOM} ±5% are pre-loaded in the factory, but the margin limits can be modified through the I²C/SMBus interface to as high as V_{NOM} + 10% or as low as 0V, where V_{NOM} is the nominal output voltage set point determined by the V0 and V1 pins. The ZL6105-01 allows 150% margin limits.

The margin limits and the MGN command can both be set individually through the I²C/SMBus interface. Additionally, the transition rate between the nominal output voltage and either margin limit can be configured through the I²C interface. Please refer to Application Note AN2033 for detailed instructions on modifying the margining configurations.

I²C/SMBus Communications

The ZL6105 provides an I²C/SMBus digital interface that enables the user to configure all aspects of the device operation as well as monitor the input and output parameters. The ZL6105 can be used with any standard 2-wire I²C host device. In addition, the device is compatible with SMBus version 2.0 and includes an SALRT line to help mitigate bandwidth limitations related to continuous fault monitoring. Pull-up resistors are required on the I²C/SMBus as specified in the SMBus 2.0 specification. The ZL6105 accepts most standard PMBus commands. When controlling the device with PMBus commands, it is recommended that the enable pin is tied to SGND.

I²C/SMBus Device Address Selection

When communicating with multiple SMBus devices using the I²C/SMBus interface, each device must have its own unique address so the host can distinguish between the devices. The device address can be set according to the pin-strap options listed in Table 21. Address values are right-justified.

TABLE 21. SMBus ADDRESS PIN-STRAP SELECTION

		SA0		
		LOW	OPEN	HIGH
SA1	LOW	0x20	0x21	0x22
	OPEN	0x23	0x24	0x25
	HIGH	0x26	0x27	Reserved

If additional device addresses are required, a resistor can be connected to the SA0 pin according to Table 22 to provide up to 25 unique device addresses. In this case, the SA1 pin should be tied to SGND.

TABLE 22. SMBus ADDRESS RESISTOR SELECTION

R _{SA0} (kΩ)	SMBus ADDRESS	R _{SA0} (kΩ)	SMBus ADDRESS
10	0x00	34.8	0x0D
11	0x01	38.3	0x0E
12.1	0x02	42.2	0x0F
13.3	0x03	46.4	0x10
14.7	0x04	51.1	0x11
16.2	0x05	56.2	0x12
17.8	0x06	61.9	0x13
19.6	0x07	68.1	0x14
21.5	0x08	75	0x15
23.7	0x09	82.5	0x16
26.1	0x0A	90.9	0x17
28.7	0x0B	100	0x18
31.6	0x0C		

If more than 25 unique device addresses are required or if other SMBus address values are desired, both the SA0 and SA1 pins can be configured with a resistor to SGND according to Equation 33 and Table 23.

$$\text{SMBus address} = 25 \times (\text{SA1 index}) + (\text{SA0 index}) \quad (\text{EQ. 33})$$

(in decimal)

Note that the SMBus address 0x4B is reserved for device test and cannot be used in the system.

TABLE 23. SMBus ADDRESS INDEX VALUES

R _{SA} (kΩ)	SA0 OR SA1 INDEX	R _{SA} (kΩ)	SA0 OR SA1 INDEX
10	0	34.8	13
11	1	38.3	14
12.1	2	42.2	15
13.3	3	46.4	16
14.7	4	51.1	17
16.2	5	56.2	18
17.8	6	61.9	19
19.6	7	68.1	20
21.5	8	75	21
23.7	9	82.5	22
26.1	10	90.9	23
28.7	11	100	24
31.6	12		

Using this method, the user can theoretically configure up to 625 unique SMBus addresses, however the SMBus is inherently limited to 128 devices so attempting to configure an address higher than 128 (0x80) will cause the device address to repeat (i.e., attempting to configure a device address of 129 (0x81) would result in a device address of 1). Therefore, the user should use index values 0 to 4 on the SA1 pin and the full range of index values on the SA0 pin, which will provide 125 device address combinations.

To determine the SA0 and SA1 resistor values given an SMBus address (in decimal), follow the indicated steps to calculate an index value and then use Table 23 to select the resistor that corresponds to the calculated index value as follows:

1. Calculate SA1 Index:

$$\text{SA1 index} = \text{Address (in decimal)} \div 25 \quad (\text{EQ. 34})$$

2. Round the result down to the nearest whole number.
3. Select the value of R1 from Table 23 using the SA1 Index rounded value from Step 2.
4. Calculate SA0 Index:

$$\text{SA0 index} = \text{Address} - (25 \times \text{SA1 Index}) \quad (\text{EQ. 35})$$

5. Select the value of R0 from Table 23 using the SA0 Index value from step 4.

Digital-DC Bus

The Digital-DC Communications (DDC) bus is used to communicate between Zilker Labs Digital-DC devices. This dedicated bus provides the communication channel between devices for features such as sequencing, fault spreading, and current sharing. The DDC pin on all Digital-DC devices in an application should be connected together. A pull-up resistor is required on the DDC bus in order to guarantee the rise time as follows:

$$\text{Risetime} = R_{\text{PU}} * C_{\text{LOAD}} \approx 1 \mu\text{s} \quad (\text{EQ. 36})$$

where R_{PU} is the DDC bus pull-up resistance and C_{LOAD} is the bus loading. The pull-up resistor may be tied to VR or to an external 3.3V or 5V supply as long as this voltage is present prior to or during device power-up. As rules of thumb, each device connected to the DDC bus presents $\sim 10\text{pF}$ of capacitive loading, and each inch of FR4 PCB trace introduces $\sim 2\text{pF}$. The ideal design will use a central pull-up resistor that is well-matched to the total load capacitance. In power module applications, the user should consider whether to place the pull-up resistor on the module or on the PCB of the end application. The minimum pull-up resistance should be limited to a value that enables any device to assert the bus to a voltage that will ensure a logic 0 (typically 0.8V at the device monitoring point) given the pull-up voltage (5V if tied to VR) and the pull-down current capability of the ZL6105 (nominally 4mA).

Phase Spreading

When multiple point of load converters share a common DC input supply, it is desirable to adjust the clock phase offset of each device such that not all devices start to switch simultaneously. Setting each converter to start its switching cycle at a different point in time can dramatically reduce input capacitance requirements and efficiency losses. Since the peak current drawn from the input supply is effectively spread out over a period of time, the peak current drawn at any given moment is reduced and the power losses proportional to the I_{RMS}^2 are reduced dramatically.

In order to enable phase spreading, all converters must be synchronized to the same switching clock. The CFG1 pin is used to set the configuration of the SYNC pin for each device as described in “Switching Frequency and PLL” on page 15.

The phase offset of each single-phase device may be set to any value between 0° and 337.5° in 22.5° increments using the CFG2 pin as shown in Tables 24 and 25.

TABLE 24. PHASE OFFSET PIN-STRAP SETTINGS

R _{CFG2}	PHASE OFFSET (°)	CURRENT SENSE
LOW	90	DCR
OPEN	0	
HIGH	180	

TABLE 25. PHASE OFFSET RESISTOR SETTINGS

R _{CFG2} (kΩ)	PHASE OFFSET (°)	CURRENT SENSE
10	22.5	DCR
11	45	
12.1	67.5	
13.3	90	
14.7	112.5	
16.2	135	
17.8	157.5	
19.6	180	
21.5	202.5	
23.7	225	
26.1	247.5	
28.7	270	
31.6	292.5	
34.8	315	
38.3	337.5	
42.2	22.5	RDS
46.4	45	
51.1	67.5	
56.2	90	
61.9	112.5	
68.1	135	
75	157.5	
82.5	180	
90.9	202.5	
100	225	
110	247.5	
121	270	
133	292.5	
147	315	
162	337.5	

The phase offset of (multi-phase) current sharing devices is automatically set to a value between 0° and 337.5° in 22.5° increments as described in “Phase Spreading” on page 27.

The phase offset of each device may also be set to any value between 0° and 360° in 22.5° increments via the I²C/SMBus interface. Refer to Application Note AN2033 for further details.

Output Sequencing

A group of Digital-DC devices may be configured to power up in a predetermined sequence. This feature is especially useful when powering advanced processors, FPGAs, and ASICs that require one supply to reach its operating voltage prior to another supply reaching its operating voltage in order to avoid latch-up from occurring. Multi-device sequencing can be achieved by configuring each device through the I²C/SMBus interface or by using Zilker Labs patented autonomous sequencing mode.

Autonomous sequencing mode configures sequencing by using events transmitted between devices over the DDC bus. This mode is not available on current sharing rails.

The sequencing order is determined using each device's SMBus address. Using autonomous sequencing mode (configured using the CFG1 pin), the devices must be assigned sequential SMBus addresses with no missing addresses in the chain. This mode will also constrain each device to have a phase offset according to its SMBus address as described in “Phase Spreading” on page 27.

The sequencing group will turn on in order starting with the device with the lowest SMBus address and will continue through to turn on each device in the address chain until all devices connected have been turned on. When turning off, the device with the highest SMBus address will turn off first followed in reverse order by the other devices in the group.

Sequencing is configured by connecting a resistor from the CFG1 pin to ground as described in Table 26. The CFG1 pin is also used to set the configuration of the SYNC pin as well as to determine the sequencing method and order. Please refer to “Switching Frequency and PLL” on page 15 for more details on the operating parameters of the SYNC pin.

Multiple device sequencing may also be achieved by issuing PMBus commands to assign the preceding device in the sequencing chain as well as the device that will follow in the sequencing chain. This method places fewer restrictions on SMBus address (no need of sequential address) and also allows the user to assign any phase offset to any device irrespective of its SMBus device address.

The Enable pins of all devices in a sequencing group must be tied together and driven high to initiate a sequenced turn-on of the group. Enable must be driven low to initiate a sequenced turnoff of the group.

Refer to Application Note AN2033 for details on sequencing via the I²C/SMBus interface.

Fault Spreading

Digital-DC devices can be configured to broadcast a fault event over the DDC bus to the other devices in the group. When a non-destructive fault occurs and the device is configured to shut down on a fault, the device will shut down and broadcast the fault event over the DDC bus. The other devices on the DDC bus will shut down together or in sequencing order if configured to do so, and will attempt to re-start in their prescribed order if configured to do so.

Temperature Monitoring Using the XTEMP Pin

The ZL6105 supports measurement of an external device temperature using either a thermal diode integrated in a processor, FPGA or ASIC, or using a discrete diode-connected 2N3904 NPN transistor. Figure 16 illustrates the typical connections required.

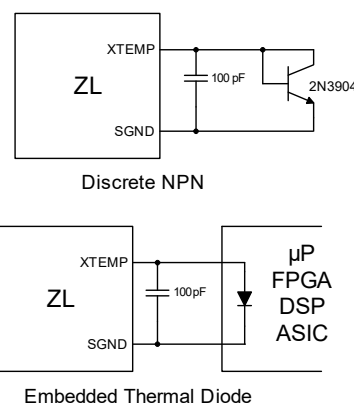

FIGURE 16. EXTERNAL TEMPERATURE MONITORING

Active Current Sharing

Paralleling multiple ZL6105 devices can be used to increase the output current capability of a single power rail. By connecting the DDC pins of each device together and configuring the devices as a current sharing rail, the units will share the current equally within a few percent.

Figure 17 illustrates a typical connection for three devices.

The ZL6105 uses a low-bandwidth, first-order digital current sharing technique to balance the unequal device output loading by aligning the load lines of member devices to a reference device.

Droop resistance is used to add artificial resistance in the output voltage path to control the slope of the load line curve, calibrating out the physical parasitic mismatches due to power train components and PCB layout. A minimum droop resistance of 0.5mΩ is recommended.

TABLE 26. SEQUENCING PIN-STRAP AND RESISTOR SETTINGS

R _{CFG1}	SYNC PIN CONFIG	SEQUENCING CONFIGURATION	NLR TIMEOUT AND BLANKING
LOW	Input	Sequencing is disabled.	1 and 4
OPEN	Auto detect		
HIGH	Output		
10kΩ	Input	Sequencing is disabled.	1 and 4
11kΩ	Auto detect		
12.1kΩ	Output		
14.7kΩ	Input	The ZL6105 is configured as the first device in a nested sequencing group. Turn on order is based on the device SMBus address.	1 and 4
16.2kΩ	Auto detect		
17.8kΩ	Output		
21.5 kΩ	Input	The ZL6105 is configured as a last device in a nested sequencing group. Turn on order is based on the device SMBus address.	1 and 4
23.7kΩ	Auto detect		
26.1kΩ	Output		
31.6kΩ	Input	The ZL6105 is configured as the middle device in a nested sequencing group. Turn on order is based on the device SMBus address.	1 and 4
34.8kΩ	Auto detect		
38.3kΩ	Output		
46.4kΩ	Input	Sequencing is disabled.	2 and 8
51.1kΩ	Auto detect		
56.2kΩ	Output		
68.1kΩ	Input	The ZL6105 is configured as the first device in a nested sequencing group. Turn on order is based on the device SMBus address.	2 and 8
75kΩ	Auto detect		
82.5kΩ	Output		
100kΩ	Input	The ZL6105 is configured as a last device in a nested sequencing group. Turn on order is based on the device SMBus address.	2 and 8
110 kΩ	Auto detect		
121kΩ	Output		
147kΩ	Input	The ZL6105 is configured as the middle device in a nested sequencing group. Turn on order is based on the device SMBus address.	2 and 8
162kΩ	Auto detect		
178kΩ	Output		

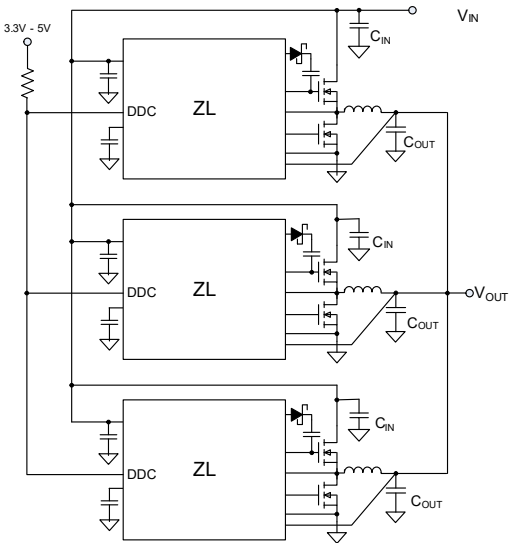

FIGURE 17. CURRENT SHARING GROUP

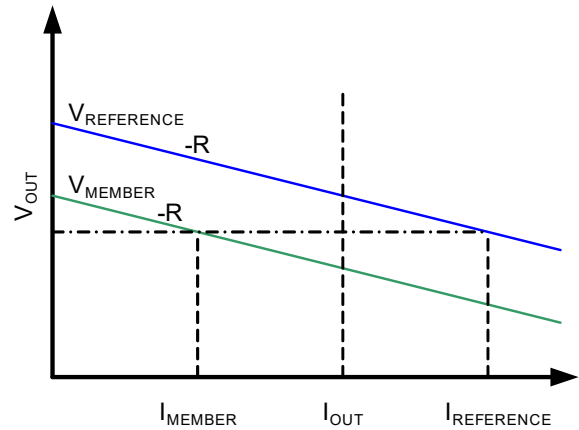

FIGURE 18. ACTIVE CURRENT SHARING

Upon system start-up, the device with the lowest member position as selected in ISHARE_CONFIG is defined as the reference device. The remaining devices are members. The reference device broadcasts its current over the DDC bus. The members use the reference current information to trim their voltages (V_{MEMBER}) to balance the current loading of each device in the system.

Figure 18 shows that, for load lines with identical slopes, the member voltage is increased towards the reference voltage which closes the gap between the inductor currents.

The relation between reference and member current and voltage is given by Equation 37:

$$V_{MEMBER} = V_{OUT} + R \times (I_{REFERENCE} - I_{MEMBER}) \quad (\text{EQ. 37})$$

where R is the value of the droop resistance.

The ISHARE_CONFIG command is used to configure the device for active current sharing. The default setting is a stand-alone non-current sharing device. A current sharing rail can be part of a system sequencing group.

For fault configuration, the current share rail is configured in a quasi-redundant mode. In this mode, when a member device fails, the remaining members will continue to operate and attempt to maintain regulation. Of the remaining devices, the device with the lowest member position will become the reference. If fault spreading is enabled, the current share rail failure is not broadcast until the entire current share rail fails.

When Auto Compensation is enabled, only two (2) devices can be configured for current sharing. With Auto Compensation disabled, up to eight (8) devices can be configured in a given current sharing rail.

TABLE 27. CURRENT SHARE POSITION SETTINGS

R _{CFG2} (kΩ)	CURRENT SHARE POSITION	CURRENT SENSE
10	0	DCR
11	1	
12.1	2	
13.3	3	
14.7	4	
16.2	5	
17.8	6	
19.6	7	
42.2	0	RDS
46.4	1	
51.1	2	
56.2	3	
61.9	4	
68.1	5	
75	6	
82.5	7	

TABLE 28. CURRENT SHARE PIN-STRAP SETTINGS

CFG0 Pin	NLR	CURRENT SHARE # OF MEMBERS	CURRENT SHARING
LOW	1.5%	0	Disabled
OPEN	Disabled		
HIGH	2%		

TABLE 29. CURRENT SHARE RESISTOR SETTINGS

R _{CFG0} (kΩ)	NLR	CURRENT SHARE # OF MEMBERS	CURRENT SHARING	
10	Disabled	2	Enabled	
11		3		
12.1		4		
13.3		5		
14.7		6		
16.2		7		
17.8		8		
19.6		3%		0
21.5	2		Enabled	
23.7	3			
26.1	4			
28.7	5			
31.6	6			
34.8	7			
38.3	8			
42.2	2%			0
46.4			2	Enabled
51.1		3		
56.2		4		
61.9		5		
68.1		6		
75		7		
82.5		8		
90.9		1.5%	0	
100			2	Enabled
110	3			
121	4			
133	5			
147	6			
162	7			
178	8			

The phase offset of a current sharing group is automatically set to a value between 0° and 337.5° in 22.5° increments as follows:

$$\text{Phase Offset} = (\text{SMBus Address}[4:0] - \text{Current Share Position}) * 22.5^\circ \quad (\text{EQ. 38})$$

The phase of the individual members in a group are spread evenly from the phase offset of the group.

Please refer to Application Note AN2034 for additional details on current sharing.

Phase Adding/Dropping

The ZL6105 allows multiple power converters to be connected in parallel to supply higher load currents than can be addressed using a single-phase design. In doing so, the power converter is optimized at a load current range that requires all phases to be operational. During periods of light loading, it may be beneficial to disable one or more phases in order to eliminate the current drain and switching losses associated with those phases, resulting in higher efficiency.

The ZL6105 offers the ability to add and drop phases using a the phase enable pin or a PMBus command in response to an observed load current change. All phases in a current share rail are considered active prior to the current sharing rail ramp to power-good.

Phases can be dropped after power-good is reached. The phase enable pin can be used to drop and add phases:

- Set PH_EN = 0 to drop a phase
- Set PH_EN = 1 to add a phase

The time to detect a change of state of the phase enable pin is between 0ms and 3ms (max).

Any member of the current sharing rail can be dropped. Any change to the number of members of a current sharing rail will precipitate autonomous phase distribution within the rail where all active phases realign their phase position based on their order within the number of active members.

If the members of a current sharing rail are forced to shut down due to an observed fault, all members of the rail will attempt to re-start simultaneously after the fault has cleared.

For single phase operation, that is, not current sharing, the PH_EN pin is ignored and can be left open.

Monitoring via I²C/SMBus

A system controller can monitor a wide variety of different ZL6105 system parameters through the I²C/SMBus interface. The device can monitor for fault conditions by monitoring the SALRT pin, which will be pulled low when any number of pre-configured fault conditions occur.

The device can also be monitored continuously for any number of power conversion parameters including but not limited to the following:

- Input voltage/Output voltage
- Output current

- Internal and external temperature
- Switching frequency
- Duty cycle

The PMBus Host should respond to SALRT as follows:

1. ZL device pulls SALRT low.
2. PMBus Host detects that SALRT is now low, performs transmission with Alert Response Address to find which ZL device is pulling SALRT low.
3. PMBus Host talks to the ZL device that has pulled SALRT low. The actions that the host performs are up to the System Designer.

If multiple devices are faulting, SALRT will still be low after doing the above steps and will require transmission with the Alert Response Address repeatedly until all faults are cleared.

Please refer to Application Note AN2033 for details on how to monitor specific parameters via the I²C/SMBus interface.

Snapshot Parameter Capture

The ZL6105 offers a special feature that enables the user to capture parametric data during normal operation or following a fault. The Snapshot functionality is enabled by setting Bit 1 of MISC_CONFIG to 1.

See AN2033 for details on using the Snapshot in addition to the parameters supported.

The Snapshot feature enables the user to read status and parameters via a block read transfer through the SMBus. This can be done during normal operation, although it should be noted that reading the 22 bytes will occupy the SMBus for some time.

The SNAPSHOT_CONTROL command enables the user to store the snapshot parameters to Flash memory in response to a pending fault as well as to read the stored data from Flash memory after a fault has occurred. Table 30 describes the usage of this command. Automatic writes to Flash memory following a fault are triggered when any fault threshold level is exceeded, provided that the specific fault's response is to shut down (writing to Flash memory is not allowed if the device is configured to re-try following the specific fault condition). It should also be noted that the device's V_{DD} voltage must be maintained during the time when the device is writing the data to Flash memory; a process that requires between 700µs to 1400µs depending on whether the data is set up for a block write. Undesirable results may be observed if the device's V_{DD} supply drops below 3.0V during this process.

TABLE 30. SNAPSHOT_CONTROL COMMAND

DATA VALUE	DESCRIPTION
1	Copies current SNAPSHOT values from Flash memory to RAM for immediate access using SNAPSHOT command.
2	Writes current SNAPSHOT values to Flash memory. Only available when device is disabled.

In the event that the device experiences a fault and power is lost, the user can extract the last SNAPSHOT parameters stored during the fault by writing a 1 to SNAPSHOT_CONTROL (transfers data from Flash memory to RAM) and then issuing a SNAPSHOT command (reads data from RAM via SMBus).

Non-Volatile Memory and Device Security Features

The ZL6105 has internal non-volatile memory where user configurations are stored. Integrated security measures ensure that the user can only restore the device to a level that has been made available to them. Refer to “Start-up Procedure” on page 13 for details on how the device loads stored values from internal memory during start-up.

During the initialization process, the ZL6105 checks for stored values contained in its internal non-volatile memory. The ZL6105 offers two internal memory storage units that are accessible by the user as follows:

1. **Default Store:** A power supply module manufacturer may want to protect the module from damage by preventing the user from being able to modify certain values that are related to the physical construction of the module. In this case, the module manufacturer would use the Default Store and would allow the user to restore the device to its default setting but would restrict the user from restoring the device to the factory settings.
2. **User Store:** The manufacturer of a piece of equipment may want to provide the ability to modify certain power supply settings while still protecting the equipment from modifying values that can lead to a system level fault. The equipment manufacturer would use the User Store to achieve this goal.

Please refer to Application Note AN2033 for details on how to set specific security measures via the I²C/SMBus interface.

License Information

This product is subject to a license from Power One, Inc. related to digital power technology as set forth in U.S. Patent No. 7,000,125 and other related patents owned by Power One, Inc. These license rights do not extend to stand-alone POL regulators unless a royalty is paid to Power One, Inc.

Revision History

The revision history provided is for informational purposes only and is believed to be accurate, but not warranted. Please go to web to make sure you have the latest Rev.

DATE	REVISION	CHANGE
Jun 22, 2021	6.0	Updated Machine Model ESD value from 500V to 200V. Removed Related Literature section. Updated Ordering Information table format. Updated links throughout. Added License Information section. Removed About Intersil section. Changed POD from L36.6x6C to L36.6x6A - change in side view MAX from 1.00 to 0.90
Dece 19, 2013	5.0	Sentence after Equation 29 on page 19 changed from "The value of R_2 should be simply 5x that of R_1 as shown in Equation 30:" to "The value of R_2 should be $2k\Omega$ ". Equation was deleted. ISENA pin. The voltage rating changed from: -1.5V to 6.5V, to: -1.5V to 30V. Changed the 6.5V to 30V on page 7 Absolute Maximum Ratings
Oct 15, 2012	4.0	Changed POD from L36.6x6A to L36.6x6C - change in side view MAX from 0.90 to 1.00 Removed all references to ZL6105-01, page 5, Ordering Information
Dec 15, 2010	3.0	In "Voltage Margining" on page 25, in the 2nd paragraph, changed the last sentence from "A safety feature prevents the user from configuring the output voltage to exceed $V_{NOM} + 10\%$ under any conditions." to "The ZL6105-01 allows 150% margin limits." Added following parts to "Ordering Information" on page 6: ZL6105ALAF-01 ZL6105ALAF-01 ZL6105ALAF-01 Updated note in MIN, MAX column of spec table from "Parameters with MIN and/or MAX limits are 100% tested at +25 °C, unless otherwise specified. Temperature limits established by characterization and are not production tested." to "Compliance to datasheet limits is assured by one or more methods: production test, characterization and/or design." Removed note "Limits established by characterization and are not production tested." and all references to it.

Revision History

The revision history provided is for informational purposes only and is believed to be accurate, but not warranted. Please go to web to make sure you have the latest Rev. (Continued)

DATE	REVISION	CHANGE
Dec 8, 2010	2.0	Added following statement to disclaimer on page 34: "This product is subject to a license from Power One, Inc. related to digital power technology as set forth in U.S. Patent No. 7,000,125 and other related patents owned by Power One, Inc. These license rights do not extend to stand-alone POL regulators unless a royalty is paid to Power One, Inc."
Sep 20, 2010	1.0	<ul style="list-style-type: none"> -Added a second sentence ("A minimum droop resistance of 0.5mΩ is recommended.") to "Active Current Sharing" on page 28 -On page 21, in Equation 31, changed "d" to "Δ". -Added "Limits established by characterization and are not production tested." to "Soft-start Delay Duration Range" on page 8, "Soft-start Ramp Duration Range" on page 8 and "VTRK Regulation Accuracy" on page 8. -Removed PG and SALRT from Conditions column of "Logic Input Leakage Current" on page 8. -Added Table 8 "MINIMUM TON DELAY vs OPERATING MODE" -Added the following paragraph to page 14: "The ZL6105 has a minimum TON_DELAY requirement ... See Application Note AN2033 for details." -Changed LOW delay time from "2" to "5" in Table 6 on page 14 -Removed first three rows (10, 11, and 12.1 rows) from Table 7 on page 14 -Rewrote paragraph directly above Figure 13 on page 21 ("When auto compensation is enabled ... as described in "Soft-Start Delay and Ramp Times" on page 14") -Changed min "Soft-start Delay Duration Range" on page 8 from 2 to 5 and 0.002 to 0.005 -Reworded Note 15 on page 9 -Changed Step 5 Description in Table 5 on page 14 -Replaced Step 5 Time Duration entry in Table 5 on page 14 with a dash ("-") -Rewrote paragraph on page 13 ("Once this process is completed...to ramp its output") -Replaced Table 16 "FC0 PIN-STRAP SETTINGS" on page 21 -Replaced Table 17 "FC1 PIN-STRAP SETTINGS" on page 22 -Rewrote the last three paragraphs of "Loop Compensation" on page 21 -Added third paragraph to "Power-Good" on page 15 ("If Auto Comp is enabled, the PG timing is further controlled by the PG Assert parameter as described "Loop Compensation" on page 20.") -Added sentence to Note 17 on page 9 ("Refer to "Soft-Start Delay and Ramp Times" on page 14 for further restrictions on PG Delay.") -In "Soft-start Delay Duration Accuracy" on page 8, in the Conditions, changed both references to Note 16 to be Note 15. Removed Note 16. -Rewrote first paragraph of "Configuration B: SYNC INPUT" on page 15 -Rewrote first three paragraphs of "Configuration C: SYNC AUTO DETECT" on page 15 -Added sentence just before Table 23 on page 26 ("Note that the SMBus address 0x4B is reserved for device test and cannot be used in the system.") On page 1, 1st sentence, changed "The ZL6105 is a digital DC/DC controller ..." to "The ZL6105 is a digital power controller ..." On page 1, 2nd paragraph, end of 1st sentence, changed from "... 3.3V to a supply operating from a 12V input" to "... 3.3V to a multiphase current sharing supply operating from a 12V input." On page 3, Figure 3, added arrow head to line going into pin 34 (PH_EN) On page 3, Note 3, 3rd sentence, corrected the ohm symbol after 10k, which was missing. On page 5, Note 1, corrected "pindependents" to "pin dependents" On page 8, "VTRK Tracking Ramp Accuracy", in the conditions column, added "no prebias" On page 9, Typ entry in table for "Current Limit Protection Delay" (condition factory default): changed from 5 to 10 On page 9, Note 15 at bottom of table, 3rd sentence, corrected from "Current Share Reference must be 10ms ...", to "Current Share Reference delay must be 10ms ..." On page 13, corrected the font size for title "SMBus Mode" (to be the same font as the title "Single Resistor Output Voltage Setting Mode") On page 14, 1st column, 2nd paragraph, "Soft-Start Delay and Ramp Times", removed last two sentences, "Precise ramp delay timing ... AN2033 for details." On page 30, 2nd column, 3rd paragraph, changed from "Up to eight (8) devices can be configured in a given current sharing rail." to "When Auto Compensation is enabled, only two (2) devices can be configured for current sharing. With Auto Compensation disabled, up to eight (8) devices can be configured in a given current sharing rail."
May 17, 2010	0.0	Initial Release

Package Outline Drawing

For the most recent package outline drawing, see [L36.6x6A](#).

L36.6x6A

36 Lead Quad Flat No-Lead Plastic Package

Rev 1, 9/09

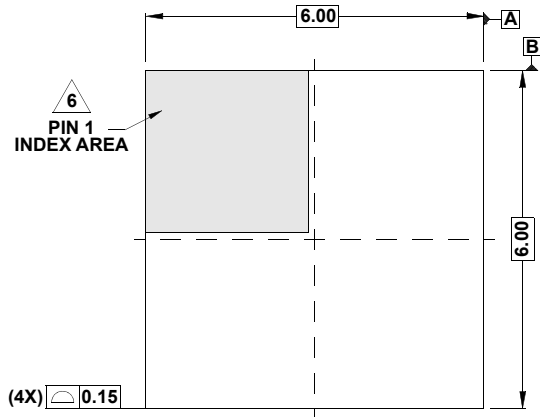

TOP VIEW

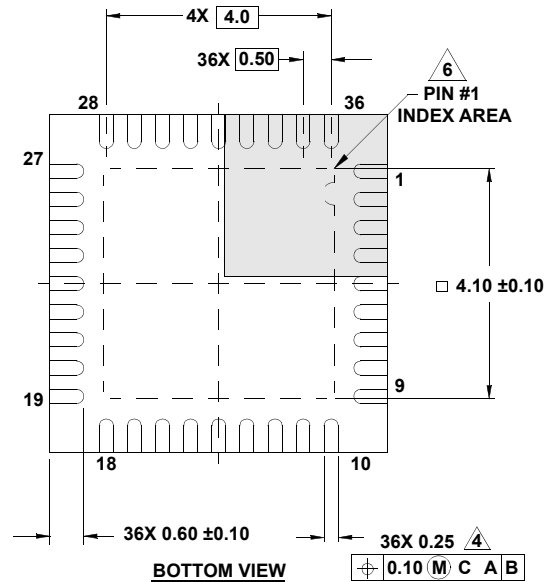

BOTTOM VIEW

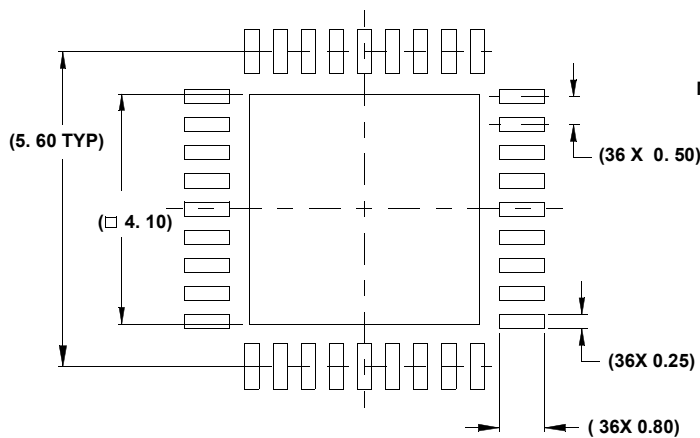

TYPICAL RECOMMENDED LAND PATTERN

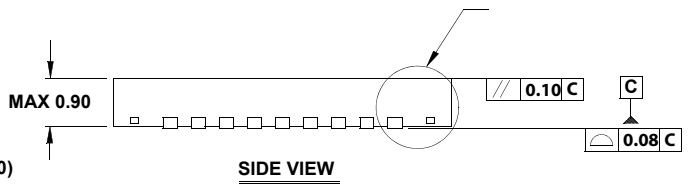

SIDE VIEW

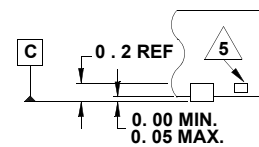

DETAIL "X"

NOTES:

1. Dimensions are in millimeters.
Dimensions in () for reference only.
2. Dimensioning and tolerancing conform to AMSE Y14.5m-1994.
3. Unless otherwise specified, tolerance: Decimal ± 0.05
4. Dimension b applies to the metallized terminal and is measured between 0.15mm and 0.30mm from the terminal tip.
5. Tiebar shown (if present) is a non-functional feature.
6. The configuration of the pin #1 identifier is optional, but must be located within the zone indicated. The pin #1 identifier may be either a mold or mark feature.
7. Compliant to JEDEC MO-220VJJD.

IMPORTANT NOTICE AND DISCLAIMER

RENESAS ELECTRONICS CORPORATION AND ITS SUBSIDIARIES (“RENESAS”) PROVIDES TECHNICAL SPECIFICATIONS AND RELIABILITY DATA (INCLUDING DATASHEETS), DESIGN RESOURCES (INCLUDING REFERENCE DESIGNS), APPLICATION OR OTHER DESIGN ADVICE, WEB TOOLS, SAFETY INFORMATION, AND OTHER RESOURCES “AS IS” AND WITH ALL FAULTS, AND DISCLAIMS ALL WARRANTIES, EXPRESS OR IMPLIED, INCLUDING, WITHOUT LIMITATION, ANY IMPLIED WARRANTIES OF MERCHANTABILITY, FITNESS FOR A PARTICULAR PURPOSE, OR NON-INFRINGEMENT OF THIRD PARTY INTELLECTUAL PROPERTY RIGHTS.

These resources are intended for developers skilled in the art designing with Renesas products. You are solely responsible for (1) selecting the appropriate products for your application, (2) designing, validating, and testing your application, and (3) ensuring your application meets applicable standards, and any other safety, security, or other requirements. These resources are subject to change without notice. Renesas grants you permission to use these resources only for development of an application that uses Renesas products. Other reproduction or use of these resources is strictly prohibited. No license is granted to any other Renesas intellectual property or to any third party intellectual property. Renesas disclaims responsibility for, and you will fully indemnify Renesas and its representatives against, any claims, damages, costs, losses, or liabilities arising out of your use of these resources. Renesas' products are provided only subject to Renesas' Terms and Conditions of Sale or other applicable terms agreed to in writing. No use of any Renesas resources expands or otherwise alters any applicable warranties or warranty disclaimers for these products.

(Rev.1.0 Mar 2020)

Corporate Headquarters

TOYOSU FORESIA, 3-2-24 Toyosu,
Koto-ku, Tokyo 135-0061, Japan
www.renesas.com

Contact Information

For further information on a product, technology, the most up-to-date version of a document, or your nearest sales office, please visit:
www.renesas.com/contact/

Trademarks

Renesas and the Renesas logo are trademarks of Renesas Electronics Corporation. All trademarks and registered trademarks are the property of their respective owners.

Looking for pricing, stock, or lifecycle information?

Click below to explore more details on WIN SOURCE:

-  [View ZL6105ALAFT on WIN SOURCE](#)
-  [Renesas Electronics America](#) Information

Optimize Your Supply Chain with WIN SOURCE Solutions

-  Global Sourcing Solution
-  Obsolete Management
-  Cost Control Management
-  Shortage Management
-  Alternative Solution
-  Excess Inventory Management