



**THE DATASHEET OF
71M6545T-IGT/F**



71M6545T/71M6545HT

Energy Meter ICs

General Description

The 71M6545T/71M6545HT metrology processors are based on Maxim Integrated's 4th-generation metering architecture supporting the 71M6xxx series of isolated current sensing products that offer drastic reduction in component count, immunity to magnetic tampering, and unparalleled reliability. The 71M6545T/71M6545HT integrate our Single Converter Technology® with a 22-bit delta sigma ADC, a customizable 32-bit computation engine (CE) for core metrology functions, as well as a user-programmable 8051-compatible application processor (MPU) core with 64KB flash and 5KB RAM.

An external host processor can access metrology functions directly through the SPI interface, or alternatively through the embedded MPU core in applications requiring metrology data capture, storage, and preprocessing within the metrology subsystem. In addition, the devices integrate an RTC, DIO, and UART. A complete array of ICE and development tools, programming libraries, and reference designs enable rapid development and certification of meters that meet all ANSI and IEC electricity metering standards worldwide.

The 71M6545T/71M6545HT operate over the industrial temperature range and come in a 64-pin lead(Pb)-free package.

Applications

- Three-Phase Residential, Commercial, and Industrial Energy Meters

Ordering Information and Typical Operating Circuit appear at end of data sheet.

Single Converter Technology is a registered trademark of Maxim Integrated Products, Inc.

MICROWIRE is a registered trademark of National Semiconductor Corp.

Benefits and Features

- SoC Integration and Unique Isolation Technique Reduces BOM Cost Without Sacrificing Performance
 - 0.1% Typical Accuracy Over 2000:1 Current Range
 - Exceeds IEC 62053/ANSI C12.20 Standards
 - Four-Quadrant Metering
 - 46-64Hz Line Frequency Range with the Same Calibration
 - Phase Compensation ($\pm 10^\circ$)
 - Independent 32-Bit Compute Engine
 - 64KB Flash, 5KB RAM
 - Built-In Flash Security
 - SPI Interface to Host with Flash Program Capability
 - Up to Four Pulse Outputs with Pulse Count
 - 8-Bit MPU (80515), Up to 5 MIPS (Optional Use)
 - Full-Speed MPU Clock in Brownout Mode
 - Up to 29 Multifunction DIO Pins
 - Hardware Watchdog Timer (WDT)
 - UART for AMR or Other Communication Duties
 - I²C/MICROWIRE® EEPROM Interface
- Innovative Isolation Technology (Requires Companion 71M6xxx Sensor, also from Maxim Integrated) Eliminates Current Transformers
 - Four Current Sensor Inputs with Selectable Differential Mode
 - Selectable Gain of 1 or 8 for One Current Input to Support Neutral Current Shunt
 - High-Speed Wh/VARh Pulse Outputs with Programmable Width
- Digital Temperature Compensation Improves System Performance
 - Metrology Compensation
 - Accurate RTC for TOU Functions with Automatic Temperature Compensation for Crystal in All Power Modes
- Power Management Extends Battery Life During Power Outages
 - Two Battery-Backup Modes
 - Brownout Mode (BRN)
 - Sleep Mode (SLP)
- Wake-Up on Pin Events and Wake-On Timer
 - 1 μ A in Sleep Mode



TABLE OF CONTENTS

General Description	1
Applications	1
Benefits and Features	1
Absolute Maximum Ratings	7
Electrical Characteristics	7
Recommended External Components	12
Pin Configuration	13
Pin Descriptions	14
Block Diagram	17
Hardware Description	18
Analog Front-End (AFE)	18
Signal Input Pins	20
Input Multiplexer	21
Delay Compensation	22
ADC Preamplifier	23
Analog-to-Digital Converter (ADC)	23
FIR Filter	23
Voltage References	23
Isolated Sensor Interface	24
Digital Computation Engine (CE)	24
Meter Equations	24
Real-Time Monitor	24
Pulse Generators	25
XPULSE and YPULSE	25
VPULSE and WPULSE	25
80515 MPU Core	25
Memory Organization and Addressing	25
Program Memory	26
MPU External Data Memory (XRAM)	26
MOVX Addressing	26
Dual Data Pointer	27
Internal Data Memory Map and Access	27
Special Function Registers	27
Timers and Counters	27
Interrupts	29
Interrupt Overview	29
External MPU Interrupts	30
On-Chip Resources	30

TABLE OF CONTENTS (continued)

Flash Memory	30
MPU/CE RAM	30
I/O RAM	30
Crystal Oscillator	31
PLL	31
Real-Time Clock (RTC)	31
RTC Trimming	31
RTC Interrupts	31
Temperature Sensor	31
Battery Monitor	32
Digital I/O	32
EEPROM Interface	32
Two-Pin EEPROM Interface	32
Three-Wire EEPROM Interface	32
UART	33
SPI Slave Port	33
SPI Safe Mode	33
SPI Flash Mode (SFM)	33
Hardware Watchdog Timer	33
Test Ports	33
Functional Description	35
Theory of Operation	35
Battery Modes	35
Brownout Mode	36
Sleep Mode	36
Applications Information	36
Connecting 5V Devices	36
Direct Connection of Sensors	36
Using the 71M6545T/HT with Local Sensors	36
Using the 71M6545T/HT with Remote Sensors	37
Metrology Temperature Compensation	37
Connecting I ² C EEPROMs	37
Connecting Three-Wire EEPROMs	37
UART	37
Reset	37
Emulator Port Pins	37
MPU Firmware Library	37
Meter Calibration	42

TABLE OF CONTENTS (continued)

Firmware Interface	42
Overview: Functional Order	42
I/O RAM Map: Details	42
Reading the Info Page	42
CE Interface Description	55
CE Program	55
CE Data Format	55
Constants	55
Environment	55
CE Calculations	56
CE Input Data	56
Status and Control	56
Transfer Variables	56
Pulse Generation	56
CE Flow Diagrams	57
Ordering Information	64
Package Information	64
Typical Operating Circuit	65
Revision History	66

LIST OF FIGURES

Figure 1. I/O Equivalent Circuits	16
Figure 2. 71M6545T/HT Operating with Local Sensors	19
Figure 3. 71M6545T/HT Operating with Remote Sensor for Neutral Current	20
Figure 4. Multiplexer Sequence with Neutral Channel and Remote Sensors	22
Figure 5. Multiplexer Sequence with Neutral Channel and Current Transformers	22
Figure 6. Waveforms Comparing Voltage, Current, Energy per Interval, and Accumulated Energy	36
Figure 7. Typical Voltage Sense Circuit Using Resistive Divider	38
Figure 8. Typical Current-Sense Circuit Using Current Transformer in a Single-Ended Configuration	38
Figure 9. Typical Current-Sense Circuit Using Current Transformer in a Differential Configuration	38
Figure 10. Typical Current-Sense Circuit Using Shunt in a Differential Configuration	38
Figure 11. 71M6545T/HT Typical Operating Circuit Using Locally Connected Sensors	39
Figure 12. 71M6545T/HT Typical Operating Circuit Using Remote Neutral Current Sensor	40
Figure 13. Typical I ² C Operating Circuit	41
Figure 14. Typical UART Operating Circuit	41
Figure 15. Typical Reset Circuits	41
Figure 16. Typical Emulator Connections	41
Figure 17. CE Data Flow—Multiplexer and ADC	63
Figure 18. CE Data Flow—Offset, Gain, and Phase Compensation	63
Figure 19. CE Data Flow—Squaring and Summation	64

LIST OF TABLES

Table 1. ADC Input Configuration	23
Table 2. Inputs Selected in Multiplexer Cycles	25
Table 3. CKMPU Clock Frequencies	26
Table 4. Memory Map	26
Table 5. Internal Data Memory Map	27
Table 6. Special Function Register Map	28
Table 7. Generic 80515 SFRs: Location and Reset Values	28
Table 8. Timers/Counters Mode Description	29
Table 9. External MPU Interrupts	30
Table 10. Test Ports	34
Table 11. Info Page Trim Fuses	43
Table 12. I/O RAM Locations in Numerical Order	44
Table 13. I/O RAM Locations in Alphabetical Order	47
Table 14. Power Equations	57
Table 15. CE Raw Data Access Locations	57
Table 16. CE Status Register	58
Table 17. CE Configuration Register	58
Table 18. Sag Threshold and Gain Adjustment Registers	59
Table 19. CE Transfer Registers	59
Table 20. CE Pulse Generation Parameters	60
Table 21. Other CE Parameters	61
Table 22. CE Calibration Parameters	62

Absolute Maximum Ratings

(All voltages referenced to GNDA.)

Supplies and Ground Pins

V _{V3P3SYS} , V _{V3P3A}	-0.5V to +4.6V
V _{BAT} , V _{BAT_RTC}	-0.5V to +4.6V
GNDD.....	-0.1V to +0.1V

Analog Output Pins

V _{REF}	-10mA to +10mA, -0.5V to (V _{V3P3A} + 0.5V)
V _{DD}	-10mA to +10mA, -0.5V to +3.0V
V _{V3P3D}	-10mA to +10mA, -0.5V to +4.6V

Analog Input Pins

IADC0-7, VADC8-10.....	-10mA to +10mA, -0.5V to (V _{V3P3A} + 0.5V)
XIN, XOUT.....	-10mA to +10mA, -0.5V to +3.0V

DIO Pins

Configured as Digital Inputs-10mA to +10mA, -0.5V to +6.0V
 Configured as Digital Outputs-10mA to +10mA, -0.5V to (V_{V3P3D} + 0.5V)

Digital Pins

Inputs (PB, RESET, RX, ICE_E, TEST).....-10mA to +10mA, -0.5V to +6.0V
 Outputs (TX)..... -10mA to +10mA, -0.5V to (V_{V3P3D} + 0.5V)

Temperature

Operating Junction Temperature (peak, 100ms)..... +140°C
 Operating Junction Temperature (continuous)..... +125°C
 Storage Temperature..... -45°C to +140°C
 Lead Temperature (soldering, 10s) +300°C
 Soldering Temperature (reflow) +260°C

Stresses beyond those listed under "Absolute Maximum Ratings" may cause permanent damage to the device. These are stress ratings only, and functional operation of the device at these or any other conditions beyond those indicated in the operational sections of the specifications is not implied. Exposure to absolute maximum rating conditions for extended periods may affect device reliability.

Electrical Characteristics

(Limits are production tested at T_A = +25°C. Limits over the operating temperature range and relevant supply voltage range are guaranteed by design and characterization.)

PARAMETER	CONDITIONS	MIN	TYP	MAX	UNITS
RECOMMENDED OPERATING CONDITIONS					
V _{V3P3SYS} and V _{V3P3A} Supply Voltage	Precision metering operation	3.0		3.6	V
V _{BAT}	PLL_FAST = 1	2.65		3.8	V
	PLL_FAST = 0	2.40		3.8	
V _{BAT_RTC}		2.0		3.8	V
Operating Temperature		-40		+85	°C
INPUT LOGIC LEVELS					
Digital High-Level Input Voltage (V _{IH})		2			V
Digital Low-Level Input Voltage (V _{IL})				0.8	V
Input Pullup Current, (I _{IL}) E_RTXT, E_RST, E_TCLK		10		100	µA
Input Pullup Current, (I _{IL}) OPT_RX, OPT_TX		10		100	µA
Input Pullup Current, (I _{IL}) SPI_CSZ (SEGDI036)		10		100	µA
Input Pullup Current, (I _{IL}) Other Digital Inputs		-1		+1	µA
Input Pulldown Current (I _{IH}), ICE_E, RESET, TEST		10		100	µA
Input Pulldown Current, (I _{IH}) Other Digital Inputs		-1		+1	µA

Electrical Characteristics (continued)

(Limits are production tested at $T_A = +25^\circ\text{C}$. Limits over the operating temperature range and relevant supply voltage range are guaranteed by design and characterization.)

PARAMETER	CONDITIONS	MIN	TYP	MAX	UNITS
OUTPUT LOGIC LEVELS					
Digital High-Level Output Voltage (V_{OH})	$I_{LOAD} = 1\text{mA}$	$V_{V3P3D} - 0.4$			V
	$I_{LOAD} = 15\text{mA}$ (Note 1)	$V_{V3P3D} - 0.8$			V
Digital Low-Level Output Voltage (V_{OL})	$I_{LOAD} = 1\text{mA}$	0		0.4	V
	$I_{LOAD} = 15\text{mA}$ (Note 1)	0		0.8	V
BATTERY MONITOR					
Battery Voltage Equation: $3.3 + (\text{BSENSE} - \text{BNOM3P3}) \times 0.0252 + \text{STEMP} \times 2.79\text{E-}5 \text{ V}$					
Measurement Error	$V_{BAT} = 2.0\text{V}$	-3.5		+3.5	%
	$V_{BAT} = 2.5\text{V}$	-3.5		+3.5	
	$V_{BAT} = 3.0\text{V}$	-3.0		+3.0	
	$V_{BAT} = 3.8\text{V}$	-3.0		+3.0	
Input Impedance		260			k Ω
Passivation Current	$I_{BAT}(\text{BCURR} = 1) - I_{BAT}(\text{BCURR} = 0)$	50	100	165	μA
TEMPERATURE MONITOR					
Temperature Measurement Equation		$22.15 + \text{STEMP} \times 0.085 - 0.0023 \times \text{STEMP} \times \frac{[(\text{STEMP}_{T85P} - \text{STEMP}_{T22P}) / (T_{85P} - T_{22P}) - 12.857]}$			$^\circ\text{C}$
Temperature Error (Note 1)	$T_A = +85^\circ\text{C}$	-3.2		+3.2	$^\circ\text{C}$
	$T_A = 0^\circ\text{C}$ to $+70^\circ\text{C}$	-2.65		+2.65	
	$T_A = -20^\circ\text{C}$	-3.4		+3.4	
	$T_A = -40^\circ\text{C}$	-3.8		+3.8	
V_{BAT_RTC} Charge per Measurement			2		μC
Duration of Temperature Measurement after TEMP_START			22	40	ms

Electrical Characteristics (continued)

(Limits are production tested at $T_A = +25^\circ\text{C}$. Limits over the operating temperature range and relevant supply voltage range are guaranteed by design and characterization.)

PARAMETER	CONDITIONS	MIN	TYP	MAX	UNITS	
SUPPLY CURRENT						
$V_{V3P3A} + V_{V3P3SYS}$ Supply Current (Note 1)	$V_{V3P3A} = V_{V3P3SYS} = 3.3\text{V}$; MPU_DIV = 3 (614kHz MPU clock); PLL_FAST = 1; PRE_E = 0		5.5	6.7	mA	
	PLL_FAST = 0		2.6	3.5		
	PRE_E = 1		5.7	6.9		
	PLL_FAST = 0, PRE_E = 1		2.6	3.6		
Dynamic Current			0.4	0.6	mA/MHz	
V_{BAT} Current	Mission mode	-300		+300	nA	
	Brownout mode		2.4	3.2	mA	
	Sleep mode	-300		+300	nA	
V_{BAT_RTC} Current	Brownout mode		400	650	nA	
	Sleep mode, $T_A \leq 25^\circ\text{C}$		0.7	1.7	μA	
	Sleep mode, $T_A = 85^\circ\text{C}$ (Note 1)		1.5	3.2	μA	
Flash Write Current	Maximum flash write rate		7.1	9.3	mA	
V_{V3P3D} SWITCH						
On-Resistance	$V_{V3P3SYS}$ to V_{V3P3D} , $I_{V3P3D} \leq 1\text{mA}$			11	Ω	
	V_{BAT} to V_{V3P3D} , $I_{V3P3D} \leq 1\text{mA}$			11		
I_{OH}		9			mA	
INTERNAL POWER FAULT COMPARATOR						
Response Time	100mV overdrive, falling	20		200	μs	
	100mV overdrive, rising			200		
Falling Threshold, 3.0V Comparator		2.83	2.93	3.03	V	
Falling Threshold, 2.8V Comparator		2.71	2.81	2.91	V	
Difference between 3.0V and 2.8V comparators		47	136	220	mV	
Falling Threshold, 2.25V Comparator		2.14	2.33	2.51	V	
Falling Threshold, 2.0V Comparator		1.90	2.07	2.23	V	
Difference between 2.25V and 2.0V Comparators		0.15	0.25	0.365	V	
Hysteresis	$T_A = +22^\circ\text{C}$	3.0V comparator	13	45	81	mV
		2.8V comparator	17	42	79	
		2.25V comparator	7	33	71	
		2.0V comparator	4	28	83	

Electrical Characteristics (continued)

(Limits are production tested at $T_A = +25^\circ\text{C}$. Limits over the operating temperature range and relevant supply voltage range are guaranteed by design and characterization.)

PARAMETER	CONDITIONS	MIN	TYP	MAX	UNITS
2.5V REGULATOR					
V_{V2P5} Output Voltage	$V_{V3P3} = 3.0\text{V to } 3.8\text{V}$, $I_{\text{LOAD}} = 0\text{mA}$	2.55	2.65	2.75	V
V_{V2P5} Load Regulation	$V_{\text{BAT}} = 3.3\text{V}$, $V_{V3P3} = 0\text{V}$, $I_{\text{LOAD}} = 0\text{mA to } 1\text{mA}$			40	mV
Dropout Voltage	$I_{\text{LOAD}} = 5\text{mA}$			440	mV
	$I_{\text{LOAD}} = 0\text{mA}$			200	
PSSR	$I_{\text{LOAD}} = 0\text{mA}$		5		mV/V
CRYSTAL OSCILLATOR					
Maximum Output Power to Crystal				1	μW
PLL					
PLL Settling Time	Power-up		3		ms
	PLL_FAST transition, low to high		3		
	PLL_FAST transition, high to low		3		
	Mode transition, sleep to mission		3		
V_{REF}					
V_{REF} Output Voltage	$T_A = +22^\circ\text{C}$	1.193	1.195	1.197	V
V_{REF} Output Impedance	$I_{\text{LOAD}} = -10\mu\text{A to } +10\mu\text{A}$			3.2	$\text{k}\Omega$
V_{REF} Power Supply Sensitivity	$V_{V3P3A} = 3.0\text{V to } 3.6\text{V}$	-1.5		+1.5	mV/V
V_{REF} Temperature Sensitivity (Note 1)		$V_{\text{REF}T} = V_{\text{REF}22} + (T-22)TC_1 + (T-22)^2TC_2$			V
	For 71M6545T	$TC_1 = 151 - 2.77 \times \text{TRIMT}$			$\mu\text{V}/^\circ\text{C}$
	For 71M6545HT	$TC_1 = 33.264 + 0.08 \times \text{TRIMT} + 1.587 \times (\text{TRIMBGB} - \text{TRIMBGD})$			$\mu\text{V}/^\circ\text{C}$
		$TC_2 = -0.528 - 0.00128 \times \text{TRIMT}$			$\mu\text{V}/^\circ\text{C}^2$
V_{REF} Error (Note 1)	71M6545T (-40°C to +85°C)	-40		+40	ppm/°C
	71M6545HT (-40°C to -20°C)	-16		+16	
	71M6545HT (-20°C to +85°C)	-10		+10	
ADC					
Recommended Input Range (All Analog Inputs, Relative to V_{V3P3A})		-250		+250	mV Peak
Recommended Input Range, IADC0-IADC1, Preamp Enabled		-31.25		+31.25	mV Peak
Input Impedance	$f_{\text{IN}} = 65\text{Hz}$	40		100	$\text{k}\Omega$
ADC Gain Error vs. Power Supply	$V_{\text{IN}} = 200\text{mV peak}$, 65Hz, $V_{V3P3A} = 3.0\text{V to } 3.6\text{V}$	-30		+70	ppm/%

Electrical Characteristics (continued)

(Limits are production tested at $T_A = +25^\circ\text{C}$. Limits over the operating temperature range and relevant supply voltage range are guaranteed by design and characterization.)

PARAMETER	CONDITIONS	MIN	TYP	MAX	UNITS
Input Offset Voltage	Differential or single-ended modes	-10		+10	mV
THD	250mV peak, 65Hz, 64k points, Blackman-Harris window, FIR_LEN = 2, ADC_DIV = 1, PLL_FAST = 1, MUX_DIV = 2		-93		dB
	20mV peak, 65Hz, 64k points, Blackman-Harris window, FIR_LEN = 2, ADC_DIV = 1, PLL_FAST = 1, MUX_DIV = 2		-90		
LSB Size	FIR_LEN = 2, ADC_DIV = 1, PLL_FAST = 1, MUX_DIV = 2		151		nV
Digital Full Scale	FIR_LEN = 2, ADC_DIV = 1, PLL_FAST = 1, MUX_DIV = 2		±2,097,152		LSB
PREAMPLIFIER					
Differential Gain		7.88	7.98	8.08	V/V
Gain Variation vs. Temperature	$T_A = -40^\circ\text{C}$ to $+85^\circ\text{C}$ (Note 1)	-30	-10	+15	ppm/ $^\circ\text{C}$
Gain Variation vs. V3P3	$V_{V3P3} = 2.97\text{V}$ to 3.63V (Note 1)	-100		+100	ppm/%
Phase Shift	(Note 1)	+10		+22	m°
Preamp Input Current		3	6	9	μA
THD, Preamp + ADC	$V_{IN} = 30\text{mV}$		-88		dB
	$V_{IN} = 15\text{mV}$		-88		
Preamp Input Offset Voltage	$I_{ADC0} = I_{ADC1} = V_{V3P3} + 30\text{mV}$		-0.63		mV
	$I_{ADC0} = I_{ADC1} = V_{V3P3} + 15\text{mV}$		-0.57		
	$I_{ADC0} = I_{ADC1} = V_{V3P3}$		-0.56		
	$I_{ADC0} = I_{ADC1} = V_{V3P3} - 15\text{mV}$		-0.56		
	$I_{ADC0} = I_{ADC1} = V_{V3P3} - 30\text{mV}$		-0.55		
Phase Shift Over Temperature	(Note 1)	-0.03		+0.03	m°/C
FLASH MEMORY					
Endurance		20,000			Cycles
Data Retention	$T_A = +25^\circ\text{C}$	100			Years
Byte Writes Between Erase Operations				2	Cycles
Write Time, per Byte	Per 2 bytes if using SPI			50	μs
Page Erase Time				22	ms
Mass Erase Time				22	ms

Electrical Characteristics (continued)

(Limits are production tested at $T_A = +25^\circ\text{C}$. Limits over the operating temperature range and relevant supply voltage range are guaranteed by design and characterization.)

PARAMETER	CONDITIONS	MIN	TYP	MAX	UNITS
SPI					
Data-to-Clock Setup Time		10			ns
Data Hold Time From Clock		10			ns
Output Delay, Clock to Data				40	ns
CS-to-Clock Setup Time		10			ns
Hold Time, CS to Clock		15			ns
Clock High Period		40			ns
Clock Low Period		40			ns
Clock Frequency (as a Multiple of CPU Frequency)				2.0	MHz/MHz
Space Between SPI Transactions		4.5			CPU Cycles
EEPROM INTERFACE					
I ² C SCL Frequency	MPU clock = 4.9MHz, using interrupts		310		kHz
	MPU clock = 4.9MHz, bit-banging DIO2-DIO3		100		
3-Wire Write Clock Frequency	MPU clock = 4.9MHz, PLL_FAST = 0		160		kHz
	MPU clock = 4.9MHz, PLL_FAST = 1		490		
RESET					
Reset Pulse Width	(Note 1)	5			μs
Reset Pulse Fall Time	(Note 1)			1	μs
INTERNAL CALENDAR					
Year Date Range		2000		2255	Years

Recommended External Components

NAME	FROM	TO	FUNCTION	VALUE	UNITS
C1	V _{V3P3A}	GNDA	Bypass capacitor for 3.3V supply	$\geq 0.1 \pm 20\%$	μF
C2	V _{V3P3D}	GNDD	Bypass capacitor for 3.3V output	$0.1 \pm 20\%$	μF
CSYS	V _{V3P3SYS}	GNDD	Bypass capacitor for V _{V3P3SYS}	$\geq 1.0 \pm 30\%$	μF
CVDD	V _{DD}	GNDD	Bypass capacitor for V _{DD}	$0.1 \pm 20\%$	μF
XTAL	XIN	XOUT	32.768 kHz crystal; electrically similar to ECS .327-12.5-17X, Vishay XT26T or Suntu SCP6–32.768kHz TR (load capacitance 12.5pF)	32.768	kHz
CXS (Note 2)	XIN	GNDA	Load capacitor values for crystal depend on crystal specifications and board parasitics. Nominal values are based on 3pF allowance for the sum of board capacitance and chip capacitance.	$22 \pm 10\%$	pF
CXL (Note 2)	XOUT	GNDA		$22 \pm 10\%$	pF

Note 1: Parameter not tested in production, guaranteed by design to six-sigma.

Note 2: If the capacitor values of CXS = 15pF and CXL = 10pF have already been installed, then changing the CXL value to 33pF and leaving CXS = 15pF would minimize rework.

Pin Configuration

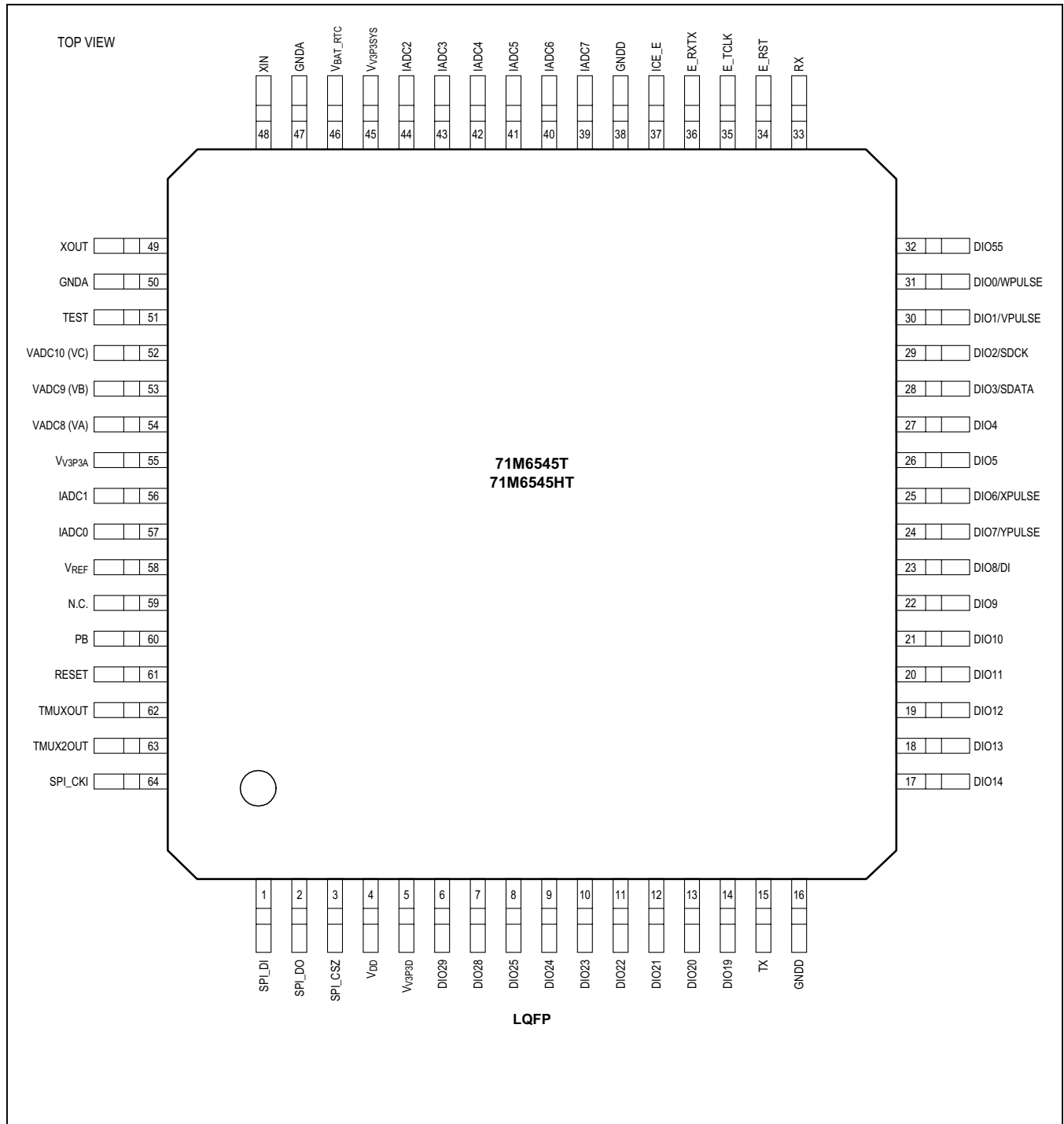

Pin Descriptions

PIN	NAME	TYPE	CIRCUIT	FUNCTION
POWER AND GROUND PINS				
47, 50	GNDA	P	—	Analog Ground. This pin should be connected directly to the ground plane.
16, 38	GNDD	P	—	Digital Ground. This pin should be connected directly to the ground plane.
55	V _{V3P3A}	P	—	Analog Power Supply. A 3.3V power supply should be connected to this pin. V _{V3P3A} must be the same voltage as V _{V3P3SYS} .
45	V _{V3P3SYS}	P	—	System 3.3V supply. This pin should be connected to a 3.3V power supply.
5	V _{V3P3D}	O	13	Auxiliary Voltage Output of the Chip. In mission mode, this pin is connected to V _{V3P3SYS} by the internal selection switch. In BRN mode, it is internally connected to V _{BAT} . V _{V3P3D} is floating in LCD and sleep mode. A 0.1μF bypass capacitor to ground must be connected to this pin.
4	V _{DD}	O	—	Output of the 2.5V Regulator. This pin is powered in MSN and BRN modes. A 0.1μF bypass capacitor to ground should be connected to this pin.
46	V _{BAT_RTC}	P	12	RTC and Oscillator Power Supply. A battery or super capacitor is to be connected between V _{BAT} and GNDD. If no battery is used, connect V _{BAT_RTC} to V _{V3P3SYS} .
ANALOG PINS				
57, 56	IADC0 IADC1	I	6	Differential or Single-Ended Line Current Sense Inputs. These pins are voltage inputs to the internal A/D converter. Typically, they are connected to the outputs of current sensors. Unused pins must be tied to V _{V3P3A} . Pins IADC2-IADC3, IADC4-IADC5 and IADC6-IADC7 may be configured for communication with the remote sensor interface (71M6x03).
44, 43	IADC2 IADC3			
42, 41	IADC4 IADC5			
40, 39	IADC6 IADC7			
54, 53, 52	VADC8 (VA), VADC9 (VB), VADC10 (VC)	I	6	Line Voltage Sense Inputs. These pins are voltage inputs to the internal A/D converter. Typically, they are connected to the outputs of resistor-dividers. Unused pins must be tied to V _{V3P3A} .
58	V _{REF}	O	9	Voltage Reference for the ADC. This pin should be left unconnected (floating).
48	XIN	I	8	Crystal Inputs. A 32.768kHz crystal should be connected across these pins. Typically, a 22pF capacitor is also connected from XIN to GNDA and a 22pF capacitor is connected from XOUT to GNDA. It is important to minimize the capacitance between these pins. See the crystal manufacturer data sheet for details. If an external clock is used, a 150mV _{p-p} clock signal should be applied to XIN, and XOUT should be left unconnected.
49	XOUT	O		

Pin Descriptions (continued)

PIN	NAME	TYPE	CIRCUIT	FUNCTION
DIGITAL PINS				
31	DIO0/WPULSE	I/O	3	Multiple-Use Pins. Alternative functions with proper selection of associated I/O RAM registers are: DIO0 = WPULSE DIO1 = VPULSE DIO2 = SDCK DIO3 = SDATA DIO4 = XPULSE DIO6 = YPULSE DIO7 = DI DIO8 = RX3 DIO16 = TX3 DIO17 = TX3 Unused pins must be configured as outputs or terminated to V3P3/GNDD.
30	DIO1/VPULSE			
29	DIO2/SDCK			
28	DIO3/SDATA			
27	DIO4			
26	DIO5			
25	DIO6/XPULSE			
24	DIO7/YPULSE			
23	DIO8/DI			
22-17	DIO[9:14]			
14-8	DIO[19:25]			
7-6	DIO[28:29]			
3	SPI_CSZ	I/O	3	SPI Interface
2	SPI_DO			
1	SPI_DI			
64	SPI_CK1			
32	DIO55	I/O	3	DIO
36	E_RXTX	I/O	1	Emulator Port Pins
34	E_RST			
35	E_TCLK	O	4	
37	ICE_E	I	2	ICE Enable. For production units, this pin should be pulled to GND to disable the emulator port.
62	TMUXOUT	O	4, 5	Multiplexer/Clock Output
63	TMUX2OUT			
61	RESET	I	2	Chip Reset. This input pin is used to reset the chip into a known state. For normal operation, this pin is pulled low. To reset the chip, this pin should be pulled high. This pin has an internal 30FA (nominal) current source pulldown. No external reset circuitry is necessary.
33	RX	I	3	UART Input. If this pin is unused it must be terminated to V _{V3P3D} or GNDD.
15	TX	O	4	UART Output
51	TEST	I	7	Enables Production Test. This pin must be grounded in normal operation.
60	PB	I	3	Pushbutton Input. This pin must be at GNDD when not active or unused. A rising edge sets the WF_PB flag. It also causes the part to wake up if it is in SLP mode. PB does not have an internal pullup or pulldown resistor.
59	N.C.	N.C.	—	No Connection. Do not connect these pins.

I = Input, O = Output, P = Power

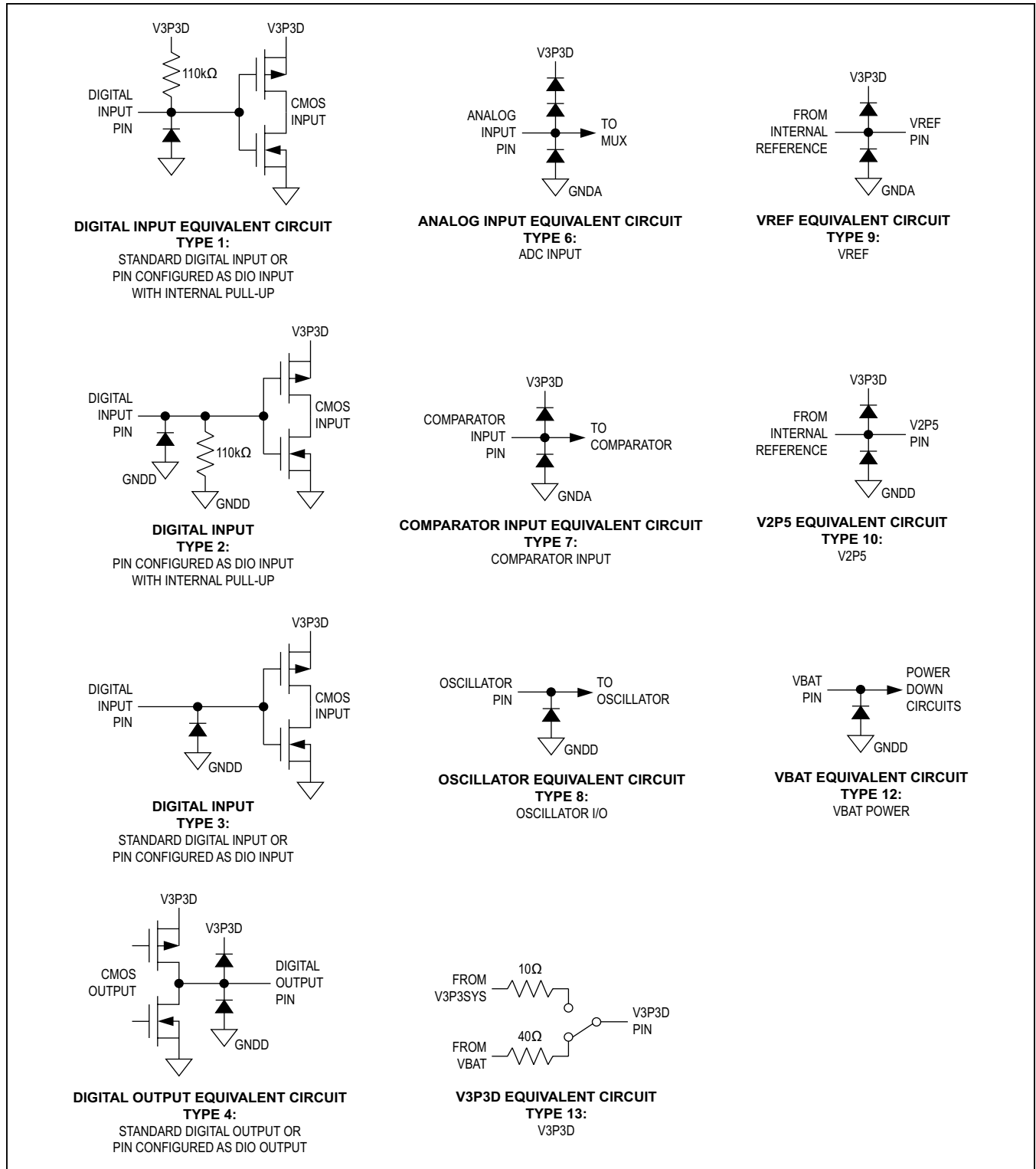
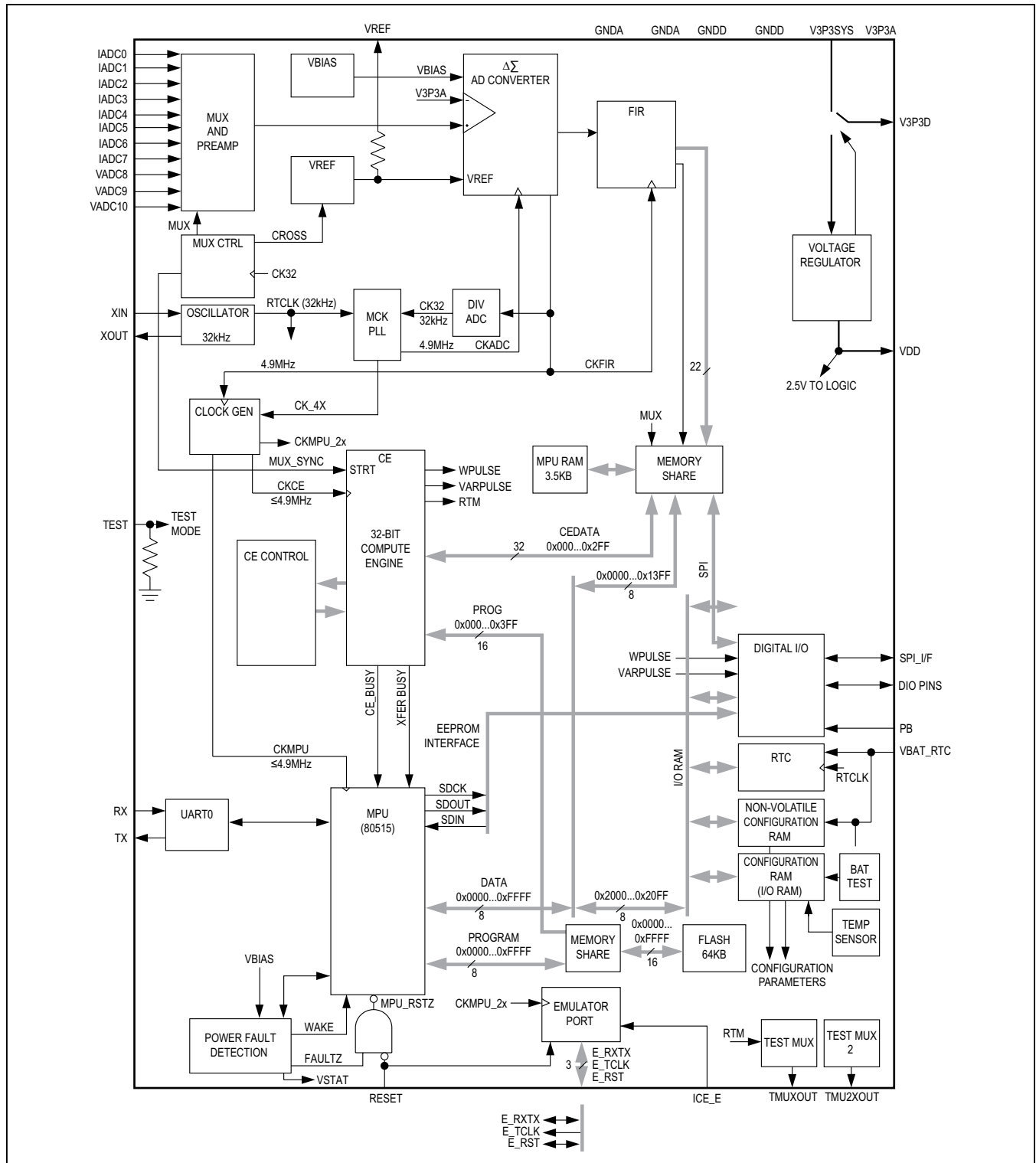

Figure 1. I/O Equivalent Circuits

Block Diagram



Hardware Description

The 71M6545T/HT single-chip energy meter ICs integrate all primary functional blocks required to implement a solid-state residential electricity meter. Included on the chip are the following:

- An analog front-end (AFE) featuring a 22-bit second-order sigma-delta ADC
- An independent 32-bit digital computation engine (CE) to implement DSP functions
- An 8051-compatible microprocessor (MPU) which executes one instruction per clock cycle (80515)
- A precision voltage reference (V_{REF})
- A temperature sensor for digital temperature compensation:
 - Metrology digital temperature compensation (MPU)
 - Automatic RTC digital temperature compensation operational in all power states
- RAM and flash memory
- A real-time clock (RTC)
- A variety of I/O pins
- A power-failure interrupt
- A zero-crossing interrupt
- Selectable current sensor interfaces for locally-connected sensors as well as isolated sensors (i.e., using the 71M6x03 companion IC with a shunt resistor sensor)
- Resistive shunt and current transformers are supported

Resistive shunts and current transformer (CT) current sensors are supported. Resistive shunt current sensors may be connected directly to the 71M654xT device or isolated using a companion 71M6x03 isolator IC in order to implement a variety of metering configurations. An inexpensive, small pulse transformer is used to isolate the 71M6x03 isolated sensor from the 71M654xT. The 71M654xT performs digital communications bidirectionally with the 71M6x03 and also provides power to the 71M6x03 through the isolating pulse transformer. Isolated (remote) shunt current sensors are connected to the differential input of the 71M6x03. Included on the 71M6x03 companion isolator chip are:

- Digital isolation communications interface
- An analog front-end (AFE)
- A precision voltage reference (V_{REF})
- A temperature sensor (for digital temperature compensation)

- A fully differential shunt resistor sensor input
- A preamplifier to optimize shunt current sensor performance
- Isolated power circuitry obtains dc power from pulses sent by the 71M654xT

In a typical application, the 32-bit compute engine (CE) of the 71M654xT sequentially processes the samples from the voltage inputs on analog input pins and from the external 71M6x03 isolated sensors and performs calculations to measure active energy (Wh) and reactive energy (VARh), as well as A²h, and V²h for four-quadrant metering. These measurements are then accessed by the MPU, processed further and output using the peripheral devices available to the MPU.

In addition to advanced measurement functions, the clock function allows the 71M6545T/HT to record time-of-use (TOU) metering information for multi-rate applications and to time-stamp tamper or other events.

In addition to the temperature-trimmed ultra-precision voltage reference, the on-chip digital temperature compensation mechanism includes a temperature sensor and associated controls for correction of unwanted temperature effects on measurement and RTC accuracy, e.g., to meet the requirements of ANSI and IEC standards. Temperature-dependent external components such as crystal oscillator, resistive shunts, current transformers (CTs) and their corresponding signal conditioning circuits can be characterized and their correction factors can be programmed to produce electricity meters with exceptional accuracy over the industrial temperature range.

See the [Block Diagram](#).

Analog Front-End (AFE)

The AFE functions as a data acquisition system, controlled by the MPU. When used with locally connected sensors, as shown in [Figure 2](#), the analog input signals (IADC0-IADC7, VADC8-VADC10) are multiplexed to the ADC input and sampled by the ADC.

The ADC output is decimated by the FIR filter and stored in CE RAM where it can be accessed and processed by the CE.

When remote isolated sensors are connected to the 71M6545T/HT using 71M6x03 remote sensor interfaces, the input multiplexer is bypassed. Instead, the extracted modulator bit stream is passed directly to a dedicated decimation filter. The output of the decimation filter is then directly stored in the appropriate CE RAM location without making use of a multiplexer cycle.

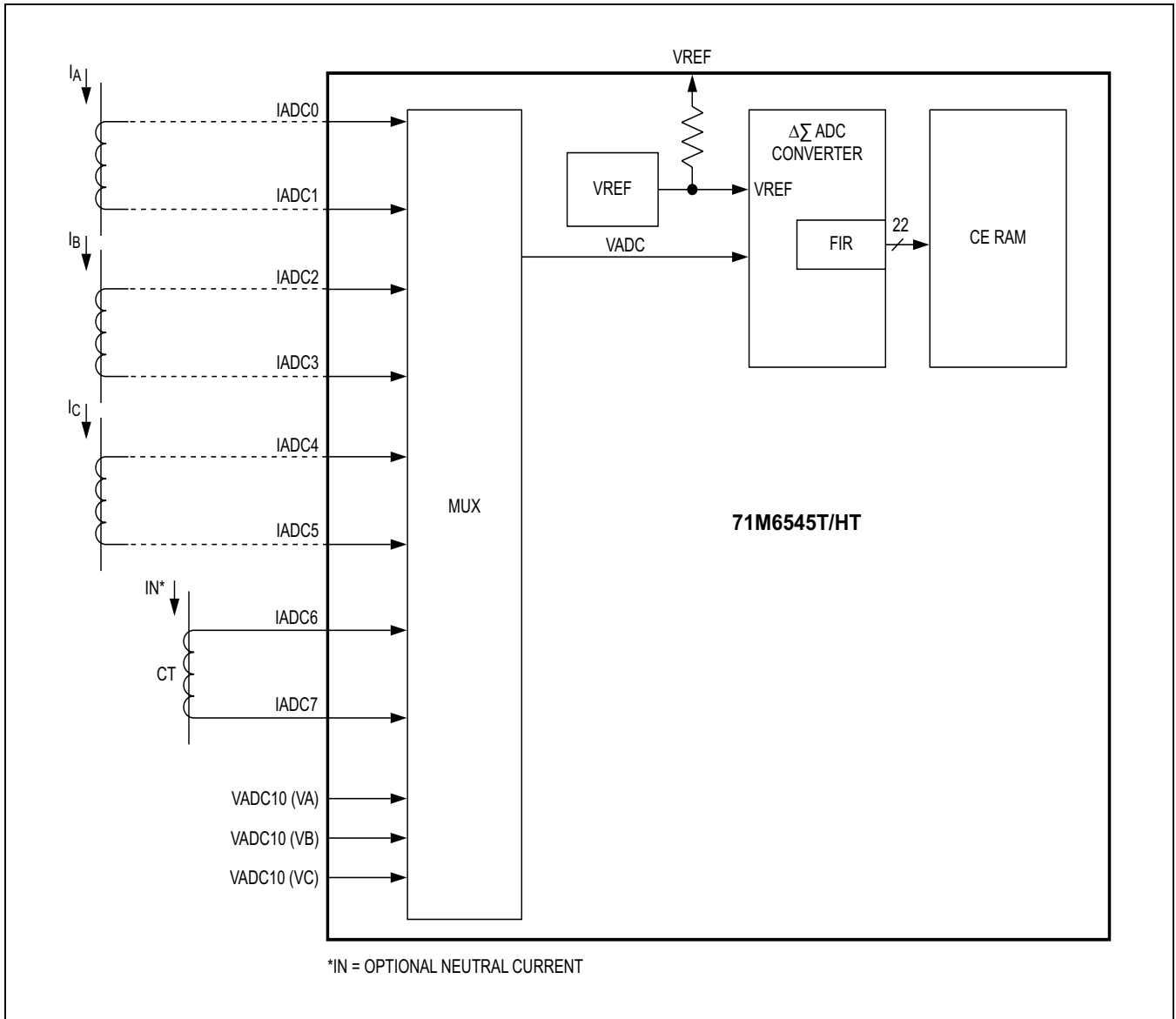

Figure 2. 71M6545T/HT Operating with Local Sensors

Signal Input Pins

The 71M6545T/HT features eleven ADC inputs.

IADC0-IADC7 are intended for use as current sensor inputs. These eight current sensor inputs can be configured as four single-ended inputs, or (more frequently) can be paired to form four differential inputs. For best performance, it is recommended to configure the current sensor inputs as differential inputs. The first differential input (IADC0-IADC1) features a preamplifier with a selectable gain of 1 or 8, and is intended for direct connection to a shunt resistor sensor, and can also be used with a current transformer (CT). The remaining differential pairs may be used with CTs, or may be enabled to interface to a remote 71M6x03 isolated current sensor providing isolation for a shunt resistor sensor using a low cost pulse transformer.

The remaining inputs (VADC8-VADC10) are single-ended and sense line voltage. These single-ended inputs are referenced to the V_{V3P3A} pin.

All analog signal input pins measure voltage. In the case of shunt current sensors, currents are sensed as a voltage drop in the shunt resistor sensor. Referring to Figure 2, shunt sensors can be connected directly to the 71M654xT (referred to as a 'local' shunt sensor) or connected through an isolated 71M6x03 (referred to as a 'remote' shunt sensor) (Figure 3). In the case of current transformers, the current is measured as a voltage across a burden resistor that is connected to the secondary winding of the CT. Meanwhile, line voltages are sensed through resistive voltage dividers.

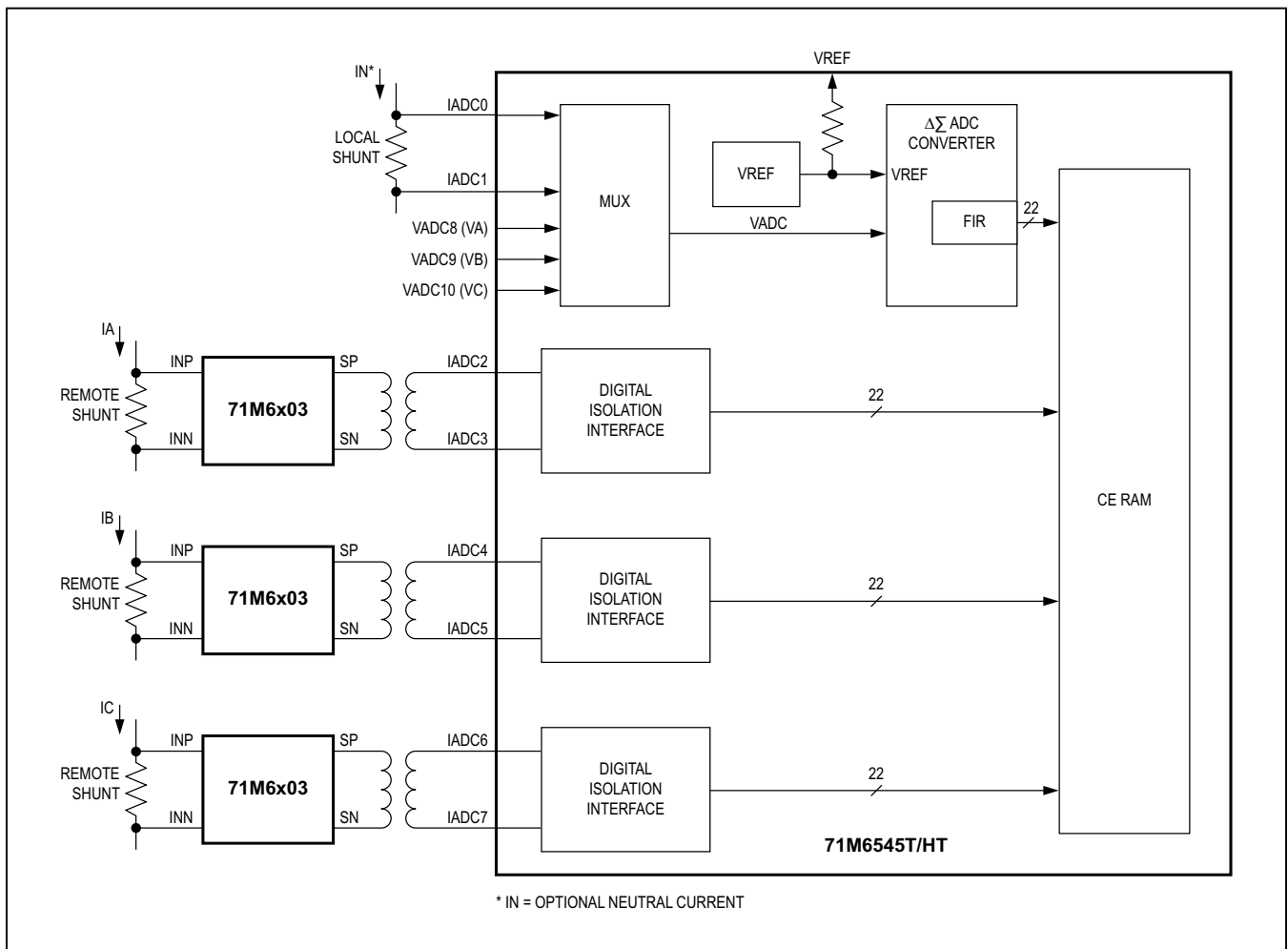

Figure 3. 71M6545T/HT Operating with Remote Sensor for Neutral Current

Pins IADC0-IADC1 can be programmed individually to be differential or single-ended. For most applications IADC0-IADC1 are configured as a differential input to work with a shunt or CT directly interfaced to the IADC0-IADC1 differential input with the appropriate external signal conditioning components.

The performance of the IADC0-IADC1 pins can be enhanced by enabling a preamplifier with a fixed gain of 8. When the PRE_E bit = 1, IADC0-IADC1 become the inputs to the 8x preamplifier, and the output of this amplifier is supplied to the multiplexer. The 8x amplification is useful when current sensors with low sensitivity, such as shunt resistors, are used. With PRE_E set, the IADC0-IADC1 input signal amplitude is restricted to 31.25 mV peak.

When shunt resistors are used as current sense elements on all current inputs, the IADC0-IADC1 pins are configured for differential mode to interface to a local shunt by setting the DIFFA_E control bit. Meanwhile, the IADC2-IADC7 pins are re-configured as digital balanced pair to communicate with a 71M6x03 isolated sensor interface by setting the RMT_E control bit. The 71M6x03 communicates with the 71M654xT using a bidirectional digital data stream through an isolating low-cost pulse transformer. The 71M654xT also supplies power to the 71M6x03 through the isolating transformer.

When using current transformers the IADC2-IADC7 pins are configured as local analog inputs (RMT_E = 0). The IADC0-IADC1 pins cannot be configured as a remote sensor interface.

Input Multiplexer

When operating with local sensors, the input multiplexer sequentially applies the input signals from the analog input pins to the input of the ADC. One complete sampling sequence is called a multiplexer frame. The multiplexer of the 71M6545T/HT can select up to seven input signals (three voltage inputs and four current inputs) per multiplexer frame. The multiplexer always starts at state 1 and proceeds until as many states as determined by MUX_DIV[3:0] have been converted.

The 71M6545T/HT requires CE code that is written for the specific application. Moreover, each CE code requires specific AFE and MUX settings in order to function properly. Contact Maxim Integrated for specific information about alternative CE codes.

For a polyphase configuration with neutral current sensing using shunt resistor current sensors and the 71M6xx3 isolated sensors, as shown in [Figure 3](#), the IADC0-IADC1 input must be configured as a differential input, to be connected to a local shunt. The local shunt connected to the IADC0-IADC1 input is used to sense the Neutral current. The voltage sensors (VADC8-VADC10) are also directly connected to the 71M6545T/HT and are also routed through the multiplexer. Meanwhile, the IADC2-IADC7 current inputs are configured as remote sensor digital interfaces and the corresponding samples are not routed through the multiplexer.

For a polyphase configuration with optional neutral current sensing using Current Transformer (CTs) sensors, all four current sensor inputs must be configured as differential inputs. IADC2-IADC3 is connected to phase A, IADC4-IADC5 is connected to phase B, and IADC6-IADC7 is connected to phase C. The IADC0-IADC1 current sensor input is optionally used to sense the Neutral current for anti-tampering purposes. The voltage sensors (VADC8-VADC10), typically resistive dividers, are directly connected to the 71M6545T/HT. No 71M6xx3 isolated sensors are used in this configuration and all signals are routed through the multiplexer.

The multiplexer sequence shown in [Figure 4](#) corresponds to the configuration shown in [Figure 3](#). The frame duration is 13 CK32 cycles (where CK32 = 32,768Hz), therefore, the resulting sample rate is $32,768\text{Hz}/13 = 2,520.6\text{Hz}$. Note that [Figure 4](#) only shows the currents that pass through the 71M6545T/HT multiplexer, and does not show the currents that are copied directly into CE RAM from the remote sensors (see [Figure 3](#)), which are sampled during the second half of the multiplexer frame. The two unused conversion slots shown are necessary to produce the desired 2,520.6Hz sample rate.

The multiplexer sequence shown in [Figure 5](#) corresponds to the CT configuration shown in [Figure 2](#). Since in this case all current sensors are locally connected to the 71M6545T/HT, all currents are routed through the multiplexer, as seen in [Figure 2](#). For this multiplexer sequence, the frame duration is 15 CK32 cycles (where CK32 = 32,768Hz), therefore, the resulting sample rate is $32,768\text{Hz}/15 = 2,184.5\text{Hz}$.

Delay Compensation

When measuring the energy of a phase (i.e., Wh and VARh) in a service, the voltage and current for that phase must be sampled at the same instant. Otherwise, the phase difference, Φ , introduces errors.

$$\phi = \frac{t_{\text{delay}}}{T} \cdot 360^\circ = t_{\text{delay}} \cdot f \cdot 360^\circ$$

Where f is the frequency of the input signal, $T = 1/f$ and t_{delay} is the sampling delay between current and voltage. Traditionally, sampling is accomplished by using two A/D converters per phase (one for voltage and the other one

for current) controlled to sample simultaneously. Our Single Converter Technology, however, exploits the 32-bit signal processing capability of its CE to implement “constant delay” allpass filters. The allpass filter corrects for the conversion time difference between the voltage and the corresponding current samples that are obtained with a single multiplexed A/D converter.

The “constant delay” allpass filter provides a broad-band delay $360^\circ - \theta$, which is precisely matched to the difference in sample time between the voltage and the current of a given phase. This digital filter does not affect the amplitude of the signal, but provides a precisely controlled phase response.

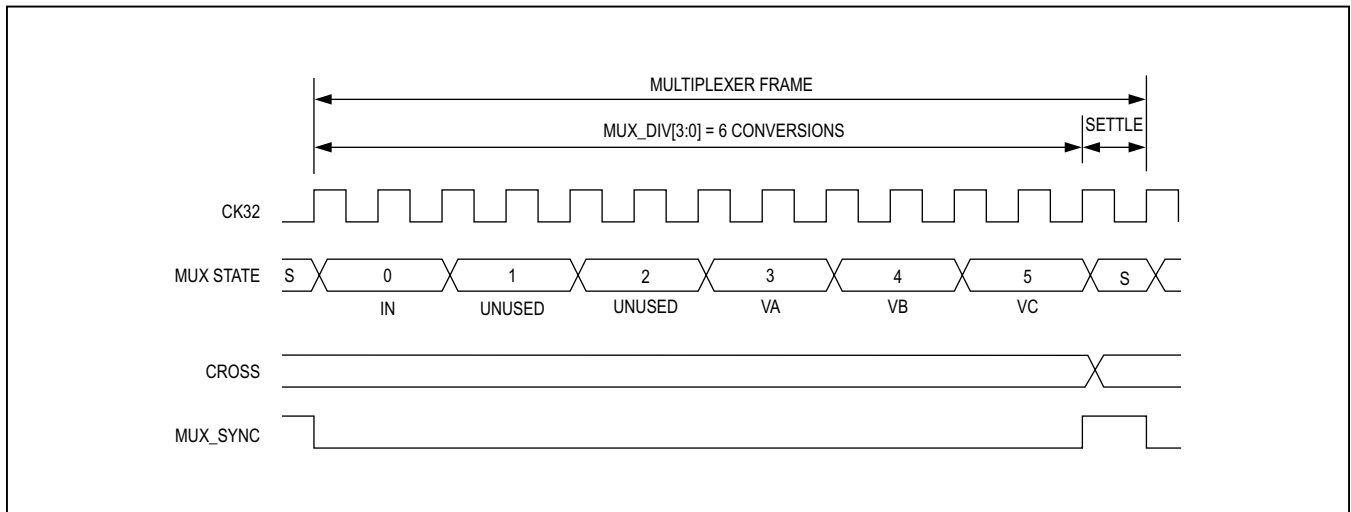

Figure 4. Multiplexer Sequence with Neutral Channel and Remote Sensors

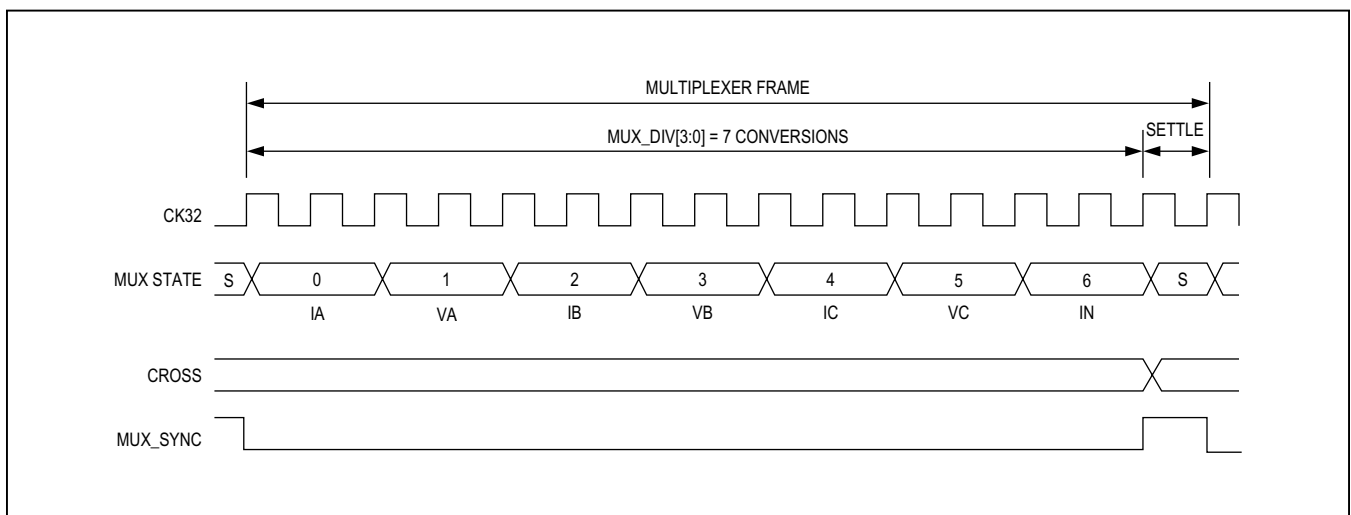

Figure 5. Multiplexer Sequence with Neutral Channel and Current Transformers

Table 1. ADC Input Configuration

PIN	REQUIRED SETTING	COMMENT
IADC0	DIFFx_E = 1	Differential mode must be selected with <i>DIFFx_E</i> = 1. The ADC results are stored in ADC0 and ADC1 is not disturbed.
IADC1		
IADC2	DIFFx_E = 1 or RMT_E = 1	For locally connected sensors the differential input must be enabled. For the remote sensor <i>RMT_E</i> must be set. ADC results are stored in <i>ADC2</i> and <i>ADC3</i> is not disturbed.
IADC3		
IADC4	DIFFx_E = 1 or RMT_E = 1	For locally connected sensors the differential input must be enabled. For the remote sensor <i>RMT_E</i> must be set. ADC results are stored in <i>ADC4</i> and <i>ADC5</i> is not disturbed.
IADC5		
IADC6	DIFFx_E = 1 or RMT_E = 1	For locally connected sensors the differential input must be enabled. For the remote sensor <i>RMT_E</i> must be set. ADC results are stored in <i>ADC6</i> and <i>ADC7</i> is not disturbed.
IADC7		
VADC8	—	Phase A voltage. Single ended mode only. ADC result stored in ADC8.
VADC9	—	Phase B voltage. Single ended mode only. ADC result stored in ADC9.
VADC10	—	Phase A voltage. Single ended mode only. ADC result stored in ADC10.

The recommended ADC multiplexer sequence samples the current first, immediately followed by sampling of the corresponding phase voltage, thus the voltage is delayed by a phase angle Φ relative to the current. The delay compensation implemented in the CE aligns the voltage samples with their corresponding current samples by first delaying the current samples by one full sample interval (i.e., 360°), then routing the voltage samples through the allpass filter, thus delaying the voltage samples by $360^\circ - \theta$, resulting in the residual phase error between the current and its corresponding voltage of $B - \Phi$. The residual phase error is negligible, and is typically less than ± 1.5 milli-degrees at 100Hz, thus it does not contribute to errors in the energy measurements.

When using remote sensors, the CE performs the same delay compensation described above to align each voltage sample with its corresponding current sample. Even though the remote current samples do not pass through the 71M654xT multiplexer, their timing relationship to their corresponding voltages is fixed and precisely known.

ADC Preampifier

The ADC preamplifier is a low-noise differential amplifier with a fixed gain of 8 available only on the IADC0-IADC1 sensor input pins. A gain of 8 is enabled by setting *PRE_E* = 1. When disabled, the supply current of the preamplifier is < 10 nA and the gain is unity. With proper settings of the *PRE_E* and *DIFFA_E* (I/O RAM 0x210C[4]) bits, the preamplifier can be used whether or not differential mode is selected. For best performance, the differential

mode is recommended. In order to save power, the bias current of the preamplifier and ADC is adjusted according to the *ADC_DIV* control bit (I/O RAM 0x2200[5]).

Analog-to-Digital Converter (ADC)

A single 2nd-order delta-sigma ADC digitizes the voltage and current inputs to the device. The resolution of the ADC, including the sign bit, is 21 bits (*FIR_LEN*[1:0] = 1), or 22 bits (*FIR_LEN*[1:0] = 2).

Initiation of each ADC conversion is controlled by *MUX_CTRL* internal circuit. At the end of each ADC conversion, the FIR filter output data is stored into the CE RAM location determined by the multiplexer selection. FIR data is stored LSB justified, but shifted left 9 bits.

FIR Filter

The finite impulse response filter is an integral part of the ADC and it is optimized for use with the multiplexer. The purpose of the FIR filter is to decimate the ADC output to the desired resolution. At the end of each ADC conversion, the output data is stored into the fixed CE RAM location determined by the multiplexer selection.

Voltage References

A bandgap circuit provides the reference voltage to the ADC. The *V_{REF}* band-gap amplifier is chopper-stabilized to remove the dc offset voltage. This offset voltage is the most significant long-term drift mechanism in voltage reference circuits.

Isolated Sensor Interface

Nonisolating sensors, such as shunt resistors, can be connected to the inputs of the 71M654xT through a combination of a pulse transformer and a 71M6x03 isolated sensor interface. The 71M6x03 receives power directly from the 71M654xT through a pulse transformer and does not require a dedicated power supply circuit. The 71M6x03 establishes 2-way communication with the 71M654xT, supplying current samples and auxiliary information such as sensor temperature through a serial data stream.

Up to three 71M6x03 isolated sensors can be supported by the 71M6545T/HT. When a remote sensor interface is enabled, the two analog current inputs become reconfigured as a digital remote sensor interface. Each 71M6x03 isolated sensor consists of the following building blocks:

- Power supply for power pulses received from the 71M654xT
- Digital communications interface
- Shunt signal preamplifier
- Delta-sigma ADC converter with precision bandgap reference (chopping amplifier)
- Temperature sensor
- Fuse system containing part-specific information

During an ordinary multiplexer cycle, the 71M654xT internally determines which other channels are enabled. At the same time, it decimates the modulator output from the 71M6x03 isolated sensors. Each result is written to CE RAM during one of its CE access time slots.

The ADC of the 71M6x03 derives its timing from the power pulses generated by the 71M654xT and as a result, operates its ADC slaved to the frequency of the power pulses. The generation of power pulses, as well as the communication protocol between the 71M654xT and 71M6x03 isolated sensor is automatic and transparent to the user.

The 71M654xT can read data and status from, and can write control information to the 71M6x03 isolated sensor. With hardware and trim-related information on each connected 71M6x03 isolated sensor available to the 71M6545T/HT, the MPU can implement temperature compensation of the energy measurement based on the individual temperature characteristics of the 71M6x03 isolated sensor.

Digital Computation Engine (CE)

The CE, a dedicated 32-bit signal processor, performs the precision computations necessary to accurately measure energy. The CE calculations and processes include:

- Multiplication of each current sample with its associated voltage sample to obtain the energy per sample (when multiplied with the constant sample time).
- Frequency-insensitive delay cancellation on all four channels (to compensate for the delay between samples caused by the multiplexing scheme).
- 90° phase shifter (for VAR calculations).
- Pulse generation.
- Monitoring of the input signal frequency (for frequency and phase information).
- Monitoring of the input signal amplitude (for sag detection).
- Scaling of the processed samples based on calibration coefficients.
- Scaling of samples based on temperature compensation information.

Meter Equations

The 71M6545T/HT provides hardware assistance to the CE in order to support various meter equations. The compute engine firmware for industrial configurations can implement the equations listed in [Table 2](#). EQU[2:0] specifies the equation to be used based on the meter configuration and on the number of phases used for metering.

Real-Time Monitor

The CE contains a real-time monitor (RTM), which can be programmed to monitor four selectable XRAM locations at full sample rate. The four monitored locations are serially output to the TMUXOUT pin via the digital output multiplexer at the beginning of each CE code pass. The RTM can be enabled and disabled with control bit RTM_E. The RTM output is clocked by CKTEST. Each RTM word is clocked out in 35 CKCE cycles (1 CKCE cycle is equivalent to 203ns) and contains a leading flag bit.

Table 2. Inputs Selected in Multiplexer Cycles

EQU	DESCRIPTION	Wh AND VARh FORMULA			RECOMMENDED MULTIPLEXER SEQUENCE
		ELEMENT 0	ELEMENT 1	ELEMENT 2	
2	2-element, 3W 3ph Delta	VA x IA	VA x IB	N/A	IA VA IB VB
3	2-element, 4W 3ph Delta	VA (IA-IB)/2	VC x IC	N/A	IA VA IB VB IC VC
4	2-element, 4W 3ph Wye	VA (IA-IB)/2	VB (IC-IB)/2	N/A	IA VA IB VB IC VC
5	3-element, 4W 3ph Wye	VA x IA	VB x IA	VC x IC	IA VA IB VB IC VC (ID)

Note: Only EQU = 5 is supported by currently available CE code versions for the 71M6545T/HT. Contact your Maxim Integrated representative for CE codes that support equations 2, 3, and 4.

Pulse Generators

The 71M6545T/HT provides four pulse generators, VPULSE, WPULSE, XPULSE and YPULSE, as well as hardware support for the VPULSE and WPULSE pulse generators. The pulse generators can be used to output CE status indicators (for example, voltage sag) to DIO pins. All pulses can be configured to generate interrupts to the MPU.

The polarity of the pulses may be inverted with control bit PLS_INV. When this bit is set, the pulses are active high, rather than the more usual active low. PLS_INV inverts all four pulse outputs.

The function of each pulse generator is determined by the CE code and the MPU code must configure the corresponding pulse outputs in agreement with the CE code. For example, standard CE code produces a mains zero-crossing pulse on XPULSE and a SAG pulse on YPULSE.

A common use of the zero-crossing pulses is to generate interrupt in order to drive real-time clock software in places where the mains frequency is sufficiently accurate to do so and also to adjust for crystal aging. A common use for the SAG pulse is to generate an interrupt that alerts the MPU when mains power is about to fail, so that the MPU code can store accumulated energy and other data to EEPROM before the V_{V3P3SYS} supply voltage actually drops.

XPULSE and YPULSE

Pulses generated by the CE may be exported to the XPULSE and YPULSE pulse output pins. Pins SEGDI06 and SEGDI07 are used for these pulses, respectively. Generally, the XPULSE and YPULSE outputs can be updated once on each pass of the CE code.

VPULSE and WPULSE

By default, WPULSE emits a pulse proportional to real energy consumed, and VPULSE emits a pulse propor-

tional to reactive energy. During each CE code pass the hardware stores exported WPULSE and VPULSE sign bits in an 8-bit FIFO and sends the buffered sign bits to the output pin at a specified, known interval. This permits the CE code to calculate the VPULSE and WPULSE outputs at the beginning of its code pass and to rely on hardware to spread them over the multiplexer frame.

80515 MPU Core

The 71M6545T/HT includes an 80515 MPU (8-bit, 8051-compatible) that processes most instructions in one clock cycle: a 4.9MHz clock results in a processing throughput of 4.9 MIPS. The 80515 architecture eliminates redundant bus states and implements parallel execution of fetch and execution phases. Normally, a machine cycle is aligned with a memory fetch, therefore, most of the 1-byte instructions are performed in a single machine cycle (MPU clock cycle). This leads to an 8x average performance improvement (in terms of MIPS) over the 8051 device running at the same clock frequency.

The CKMPU frequency is a function of the MCK clock (19.6608MHz) divided by the MPU clock divider which is set in the I/O RAM control field MPU_DIV[2:0]. Actual processor clocking speed can be adjusted to the total processing demand of the application (metering calculations, AMR management, memory management, and I/O management) using MPU_DIV[2:0], as shown in [Table 3](#).

Memory Organization and Addressing

The 80515 MPU core incorporates the Harvard architecture with separate code and data spaces. Memory organization in the 80515 is similar to that of the industry standard 8051. There are three memory areas: program memory (flash, shared by MPU and CE), external RAM (data RAM, shared by the CE and MPU, configuration or I/O RAM), and internal data memory (internal RAM).

Program Memory

The 80515 can address up to 64KB of program memory space (0x0000 to 0xFFFF). Program memory is read when the MPU fetches instructions or performs a MOVC operation.

After reset, the MPU starts program execution from program memory location 0x0000. The lower part of the program memory includes reset and interrupt vectors. The interrupt vectors are spaced at 8-byte intervals, starting from code space location 0x0003.

MPU External Data Memory (XRAM)

Both internal and external memory is physically located on the 71M654xT device. The external memory referred

in this documentation is only external to the 80515 MPU core.

3KB of RAM starting at address 0x0000 is shared by the CE and MPU. The CE normally uses the first 1KB, leaving 2KB for the MPU. Different versions of the CE code use varying amounts. Consult the documentation for the specific code version being used for the exact limit.

MOVX Addressing

There are two types of instructions differing in whether they provide an 8-bit or 16-bit indirect address to the external data RAM:

- **MOVX A,@Ri:** The contents of R0 or R1 in the current register bank provide the eight low-order address bits with the eight high-order bits specified by the PDATA SFR. This method allows the user paged access (256 pages of 256 bytes each) to all ranges of the external data RAM.
- **MOVX A,@DPTR:** The data pointer generates a 16-bit address. This form is faster and more efficient when accessing very large data arrays (up to 64KB) since no additional instructions are needed to set up the eight high ordered bits of the address.

It is possible to mix the two MOVX types. This provides the user with four separate data pointers, two with direct access and two with paged access, to the entire external memory range.

Table 3. CKMPU Clock Frequencies

MPU_DIV [2:0]	CKMPU FREQUENCY
000	4.9152MHz
001	2.4576MHz
010	1.2288MHz
011	614.4kHz
100	307.2kHz
101	
110	
111	

Table 4. Memory Map

ADDRESS (hex)	MEMORY TECHNOLOGY	MEMORY TYPE	NAME	TYPICAL USAGE	MEMORY SIZE (BYTES)
0000-FFFF (64K)	Flash Memory	Nonvolatile	Program memory for MPU and CE	MPU program and nonvolatile data	64K
				CE program (on 1KB boundary)	3K max
0000-0BFF	Static RAM	Volatile	External RAM (XRAM)	Shared by CE and MPU	5K
2000-27FF	Static RAM	Volatile	Configuration RAM (I/O RAM)	Hardware control	2K
2800-287F	Static RAM	Nonvolatile (battery)	Configuration RAM (I/O RAM)	Battery-buffered memory	128
0000-00FF	Static RAM	Volatile	Internal RAM	Part of 80515 Core	256

Dual Data Pointer

The Dual Data Pointer accelerates the block moves of data. The standard DPTR is a 16-bit register that is used to address external memory or peripherals. In the 80515 core, the standard data pointer is called DPTR, the second data pointer is called DPTR1. The data pointer select bit, located in the LSB of the DPS register, chooses the active pointer. DPTR is selected when DPS[0] = 0 and DPTR1 is selected when DPS[0] = 1.

The user switches between pointers by toggling the LSB of the DPS register. The values in the data pointers are not affected by the LSB of the DPS register. All DPTR related instructions use the currently selected DPTR for any activity.

An alternative data pointer is available in the form of the PDATA register (SFR 0xBF), sometimes referred to as USR2). It defines the high byte of a 16-bit address when reading or writing XDATA with the instruction MOVX A,@ Ri or MOVX @Ri,A.

Internal Data Memory Map and Access

The Internal data memory provides 256 bytes (0x00 to 0xFF) of data memory. The internal data memory address is always 1 byte wide.

The Special Function Registers (SFR) occupy the upper 128 bytes. The SFR area of internal data memory is available **only by direct addressing**. Indirect addressing of this area accesses the upper 128 bytes of Internal RAM. The lower 128 bytes contain working registers and bit addressable memory. The lower 32 bytes form four banks of eight registers (R0-R7). Two bits on the program memory status word (PSW, SFR 0xD0) select which bank is in use. The next 16 bytes form a block of bit address-

able memory space at addresses 0x00-0x7F. All of the bytes in the lower 128 bytes are accessible through direct or indirect addressing.

Special Function Registers

Only a few addresses in the SFR memory space are occupied; other addresses are unimplemented. A read access to unimplemented addresses returns undefined data, while a write access has no effect. SFRs specific to the 71M654xT are shown in bold print on a shaded field. The registers at 0x80, 0x88, 0x90, etc., are bit addressable, all others are byte addressable.

Timers and Counters

The 71M6545T/HT contains two 16-bit timer/counter registers: Timer 0 and Timer 1. These registers can be configured for counter or timer operations.

In timer mode, the register is incremented every machine cycle, i.e., it counts up once for every 12 periods of the MPU clock. In counter mode, the register is incremented when the falling edge is observed at the corresponding input signal T0 or T1 (T0 and T1 are the timer gating inputs derived from certain DIO pins, see 2.5.8 Digital I/O). Since it takes 2 machine cycles to recognize a 1-to-0 event, the maximum input count rate is 1/2 of the clock frequency (CKMPU). There are no restrictions on the duty cycle, however to ensure proper recognition of the 0 or 1 state, an input should be stable for at least 1 machine cycle.

Four operating modes can be selected for Timer 0 and Timer 1. The TMOD register is used to select the appropriate mode. The timer/counter operation is controlled by the TCON register. Bits TR1 and TR0 in the TCON register start their associated timers when set.

Table 5. Internal Data Memory Map

ADDRESS RANGE		DIRECT ADDRESSING	INDIRECT ADDRESSING
0x80	0xFF	Special Function Registers (SFRs)	RAM
0x30	0x7F	Byte addressable area	
0x20	0x2F	Bit addressable area	
0x00	0x1F	Register banks R0...R7	

Table 6. Special Function Register Map

HEX/ BIN	BIT ADDRESSABLE	BYTE ADDRESSABLE							BIN/ HEX
	X000	X001	X010	X011	X100	X101	X110	X111	
F8	INTBITS	VSTAT			RCMD	SPI_CMD			FF
F0	B								F7
E8	IFLAGS								EF
E0	A								E7
D8	WDCON								DF
D0	PSW								D7
C8	T2CON								CF
C0	IRCON								C7
B8	IEN1	IP1	S0RELH	S1RELH				PDATA	BF
B0	P3 (DIO12:15)		FLSH_CTL					FLSH_PGADR	B7
A8	IEN0	IP0	S0RELL						AF
A0	P2 (DIO8:11)								A7
98	S0CON	S0BUF	IEN2	S1CON	S1BUF	S1RELL	EEDATA	EECTRL	9F
90	P1(DIO4:7)		DPS		FLH_ERASE				97
88	TCON	TMOD	TL0	TL1	TH0	TH1	CKCON		8F
80	P0 (DIO0:3)	SP	DPL	DPH	DPL1	DPH1		PCON	87

Table 7. Generic 80515 SFRs: Location and Reset Values

NAME	ADDRESS	RESET VALUE	DESCRIPTION
P0	0x80	0xFF	Port 0
SP	0x81	0x07	Stack Pointer
DPL	0x82	0x00	Data Pointer Low 0
DPH	0x83	0x00	Data Pointer High 0
DPL1	0x84	0x00	Data Pointer Low 1
DPH1	0x85	0x00	Data Pointer High 1
PCON	0x87	0x00	UART Speed Control
TCON	0x88	0x00	Timer/Counter Control
TMOD	0x89	0x00	Timer Mode Control
TL0	0x8A	0x00	Timer 0, low byte
TL1	0x8B	0x00	Timer 1, high byte
TH0	0x8C	0x00	Timer 0, low byte
TH1	0x8D	0x00	Timer 1, high byte
CKCON	0x8E	0x01	Clock Control (Stretch = 1)
P1	0x90	0xFF	Port 1
DPS	0x92	0x00	Data Pointer select Register
S0CON	0x98	0x00	Serial Port 0, Control Register
S0BUF	0x99	0x00	Serial Port 0, Data Buffer
IEN2	0x9A	0x00	Interrupt Enable Register 2
S1CON	0x9B	0x00	Serial Port 1, Control Register

Table 7. Generic 80515 SFRs - Location and Reset Values (continued)

NAME	ADDRESS	RESET VALUE	DESCRIPTION
S1BUF	0x9C	0x00	Serial Port 1, Data Buffer
S1RELL	0x9D	0x00	Serial Port 1, Reload Register, low byte
P2	0xA0	0xFF	Port 2
IEN0	0xA8	0x00	Interrupt Enable Register 0
IP0	0xA9	0x00	Interrupt Priority Register 0
S0RELL	0xAA	0xD9	Serial Port 0, Reload Register, low byte
P3	0xB0	0xFF	Port 3
IEN1	0xB8	0x00	Interrupt Enable Register 1
IP1	0xB9	0x00	Interrupt Priority Register 1
S0RELH	0xBA	0x03	Serial Port 0, Reload Register, high byte
S1RELH	0xBB	0x03	Serial Port 1, Reload Register, high byte
PDATA	0xBF	0x00	High address byte for MOVX@Ri - also called <i>USR2</i>
IRCON	0xC0	0x00	Interrupt Request Control Register
T2CON	0xC8	0x00	Polarity for INT2 and INT3
PSW	0xD0	0x00	Program Status Word
WDCON	0xD8	0x00	Baud Rate Control Register (only WDCON[7] bit used)
A	0xE0	0x00	Accumulator
B	0xF0	0x00	B Register

Table 8. Timers/Counters Mode Description

M1	M0	MODE	FUNCTION
0	0	Mode 0	13-bit Counter/Timer mode with 5 lower bits in the <i>TL0</i> or <i>TL1</i> register and the remaining 8 bits in the <i>TH0</i> or <i>TH1</i> register (for Timer 0 and Timer 1, respectively). The 3 high order bits of <i>TL0</i> and <i>TL1</i> are held at zero.
0	1	Mode 1	16-bit Counter/Timer mode.
1	0	Mode 2	8-bit auto-reload Counter/Timer. The reload value is kept in <i>TH0</i> or <i>TH1</i> , while <i>TL0</i> or <i>TL1</i> is incremented every machine cycle. When <i>TLx</i> overflows, a value from <i>THx</i> is copied to <i>TLx</i> .
1	1	Mode 3	If Timer 1 <i>M1</i> and <i>M0</i> bits are set to 1, Timer 1 stops. If Timer 0 <i>M1</i> and <i>M0</i> bits are set to 1, Timer 0 acts as two independent 8-bit Timer/Counters.

Interrupts

The 80515 provides 11 interrupt sources with four priority levels. Each source has its own interrupt request flag(s) located in a special function register (TCON, IRCON, and SCON). Each interrupt requested by the corresponding interrupt flag can be individually enabled or disabled by the interrupt enable bits in the IEN0, IEN1, and IEN2.

Referring to [Figure 12](#), interrupt sources can originate from within the 80515 MPU core (referred to as Internal Sources) or can originate from other parts of the 71M654xT SoC (referred to as External Sources). There are seven external interrupt sources, (EX0-EX6).

Interrupt Overview

When an interrupt occurs, the MPU vectors to the predetermined address. Once the interrupt service has begun, it can be interrupted only by a higher priority interrupt. The interrupt service is terminated by a return from interrupt instruction (RETI). When a RETI instruction is executed, the processor returns to the instruction that would have been next when the interrupt occurred.

When the interrupt condition occurs, the processor also indicates this by setting a flag bit. This bit is set regardless of whether the interrupt is enabled or disabled. Each interrupt flag is sampled once per machine cycle, and then

samples are polled by the hardware. If the sample indicates a pending interrupt when the interrupt is enabled, then the interrupt request flag is set. On the next instruction cycle, the interrupt is acknowledged by hardware forcing an LCALL to the appropriate vector address, if the following conditions are met:

- No interrupt of equal or higher priority is already in progress.
- An instruction is currently being executed and is not completed.
- The instruction in progress is not RETI or any write access to the registers IEN0, IEN1, IEN2, IP0 or IP1.

The following SFR registers control the interrupt functions:

- The interrupt enable registers: IEN0, IEN1 and IEN2.
- The Timer/Counter control registers, TCON and T2CON.
- The interrupt request register, IRCON.
- The interrupt priority registers: IP0 and IP1.

External MPU Interrupts

The seven external interrupts are the interrupts external to the 80515 core, i.e., signals that originate in other parts of the 71M654xT, for example the CE, DIO, RTC, or EEPROM interface.

The polarity of interrupts 2 and 3 is programmable in the MPU via the I3FR and I2FR bits in T2CON (SFR 0xC8). Interrupts 2 and 3 should be programmed for falling sensitivity (I3FR = I2FR = 0). The generic 8051 MPU literature states that interrupts 4 through 6 are defined as rising-edge sensitive. Thus, the hardware signals attached to interrupts 5 and 6 are inverted to achieve the edge polarity shown in [Table 9](#).

External interrupt 0 and 1 can be mapped to pins on the device using DIO resource maps.

Table 9. External MPU Interrupts

EXTERNAL INTERRUPT	CONNECTION	POLARITY	FLAG RESET
0	Digital I/O (IE0)	Programmable	Automatic
1	Digital I/O (IE1)	Programmable	Automatic
2	CE_PULSE (IE_XPULSE, IE_YPULSE, IE_WPLUSE, IE_VPULSE)	Rising	Manual
3	CE_BUSY (IE3)	Falling	Automatic
4	VSTAT (VSTAT[2:0] changed) (IE4)	Rising	Automatic
5	EEPROM busy (falling), SPI (rising) (IE_EEX, IE_SPI)	—	Manual
6	XFER_BUSY (falling), RTC_1SEC, RTC_1MIN, RTC_T, TC_TEMP (IE_XFER, IE_RTC1S, IE_RTC1M, IE_RTCT)	Falling	Manual

On-Chip Resources

Flash Memory

The device includes 64KB of on-chip flash memory. The flash memory primarily contains MPU and CE program code. It also contains images of the CE RAM and I/O RAM. On power-up, before enabling the CE, the MPU copies these images to their respective locations.

Flash space allocated for the CE program is limited to 4096 16-bit words (8KB). The CE program must begin on a 1KB boundary of the flash address space. The CE_LCTN[5:0] field defines where in flash the CE code resides. The address of the CE program is 0bXXXX XX00 0000 0000, where XXXX XX represents one of the 64 1KB pages at which the CE program begins.

Flash memory can be accessed by the MPU and the CE for reading, and by the SPI interface for reading or writing.

MPU/CE RAM

The 71M6545T/HT includes 5KB of static RAM memory on-chip (XRAM) plus 256 bytes of internal RAM in the MPU core. The static RAM is used for data storage for both MPU and CE operations.

I/O RAM

The I/O RAM can be seen as a series of hardware registers that control basic hardware functions. I/O RAM address space starts at 0x2000.

The 71M6545T/HT includes 128 bytes NV RAM memory on-chip in the I/O RAM address space (addresses 0x2800 to 0x287F). This memory section is supported by the voltage applied at V_{BAT_RTC} and the data in it are preserved in BRN, LCD, and SLP modes as long as the voltage at V_{BAT_RTC} is within specification.

Crystal Oscillator

The oscillator drives a standard 32.768kHz tuning-fork crystal. This type of crystal is accurate and does not require a high-current oscillator circuit. The oscillator power dissipation is very low to maximize the lifetime of the V_{BAT_RTC} battery.

Oscillator calibration can improve the accuracy of both the RTC and metering.

PLL

Timing for the device is derived from the 32,768Hz crystal oscillator. The oscillator output is routed to a phase-locked loop (PLL). The PLL multiplies the crystal frequency by 600 to produce a stable 19.6608MHz clock frequency. This is the master clock (MCK), and all on-chip timing, except for the RTC clock, is derived from MCK.

The master clock can operate at either 19.66MHz or 6.29MHz depending on the PLL_FAST bit. The MPU clock frequency CKMPU is determined by another divider controlled by the I/O RAM control field MPU_DIV[2:0] and can be set to $MCK \times 2^{-(MPU_DIV+2)}$, where MPU_DIV[2:0] may vary from 0 to 4. The 71M654xT $V_{V3P3SYS}$ supply current is reduced by reducing the MPU clock frequency. When the ICE_E pin is high, the circuit also generates the 9.83MHz clock for use by the emulator.

The two general-purpose counter/timers contained in the MPU are clocked by CKMPU.

The PLL is only turned off in SLP mode.

When the part is waking up from SLP mode, the PLL is turned on in 6.29MHz mode, and the PLL frequency is not be accurate until the PLL_OK flag becomes active. Due to potential overshoot, the MPU should not change the value of PLL_FAST until PLL_OK is true.

Real-Time Clock (RTC)

The real-time clock is driven directly by the crystal oscillator and is powered by either the $V_{V3P3SYS}$ pin or the V_{BAT_RTC} pin, depending on the V3OK internal bit. The RTC consists of a counter chain and a set of output registers. The counter chain consists of registers for seconds, minutes, hours, day of week, day of month, month, and year. The chain registers are supported by a shadow register that facilitates read and write operations.

RTC Trimming

The RTC accuracy can be trimmed by means of a digital trimming mechanism that affects only the RTC. Either or both of these adjustment mechanisms can be used to trim the RTC.

The 71M6545T/HT can also be configured to regularly measure die temperature, including in SLP mode and while the MPU is halted. If enabled, the temperature information is automatically used to correct for the temperature variation of the crystal. A quadratic equation is used to compute the temperature correction factors.

The temperature is passed both to the quadratic calculation block and to a range check block. If the temperature exceeds the limits established in the SMIN, SMAX and SFILT registers when a range checking is enabled, a WAKE or an INTERRUPT event is posted.

The quadratic calculation block computes the position on the inverse parabolic curve that is characteristic for tuning fork crystals based on the known α and T_0 values for the crystal (these are published by the crystal manufacturer and are relatively consistent for a particular crystal type). Finally, the absolute frequency error is added or subtracted from the computed value, and the final result is used to compensate the frequency of the crystal.

RTC Interrupts

The RTC generates interrupts each second and each minute. These interrupts are called RTC_1SEC and RTC_1MIN. In addition, the RTC functions as an alarm clock by generating an interrupt when the minutes and hours registers both equal their respective target counts as defined in the alarm registers. The alarm clock interrupt is called RTC_T. All three interrupts appear in the MPU's external interrupt 6.

Temperature Sensor

The 71M654xT includes an on-chip temperature sensor for determining the temperature of its bandgap reference. The primary use of the temperature data is to determine the magnitude of compensation required to offset the thermal drift in the system for the compensation of current, voltage and energy measurement and the RTC. See the [Metrology Temperature Compensation](#).

The 71M654xT uses a dual-slope temperature measurement technique that is operational in SLP mode, as well as BRN and MSN modes. This means that the temperature sensor can be used to compensate for the frequency variation of the crystal, even in SLP mode while the MPU is halted.

In MSN and BRN modes, the temperature sensor is awakened on command from the MPU by setting the TEMP_START control bit. The MPU must wait for the TEMP_START bit to clear before reading STEMP[15:0] and before setting the TEMP_START bit once again.

In SLP mode, it is awakened at a regular rate set by TEMP_PER[2:0].

The result of the temperature measurement can be read from STEMP[15:0]. Typically, only eleven bits are significant, the remaining high-order bits reflecting the sign of the temperature relative to 0C.

Battery Monitor

The 71M654xT temperature measurement circuit can also monitor the batteries at the V_{BAT} and V_{BAT_RTC} pins. The battery to be tested (i.e., V_{BAT} or V_{BAT_RTC} pin) is selected by TEMP_BSEL.

When TEMP_BAT is set, a battery measurement is performed as part of each temperature measurement. The value of the battery reading is stored in register BSENSE[7:0]. The battery voltage can be calculated by using the formula in the [BATTERY MONITOR](#) section of the electrical characteristics table.

In MSN mode, a 100µA de-passivation load can be applied to the selected battery (i.e., selected by the TEMP_BSEL bit) by setting the BCURR bit. Battery impedance can be measured by taking a battery measurement with and without BCURR. Regardless of the BCURR bit setting, the battery load is never applied in BRN, LCD, and SLP modes.

Digital I/O

On reset or power-up, all DIO pins are DIO inputs until they are configured as desired under MPU control.

DIO pins can be configured independently as an input or output. The PB pin is a dedicated digital input and is not part of the DIO system.

Some pins (DIO2 through DIO11 and PB) can be routed to internal logic such as the interrupt controller or a timer channel. This routing is independent of the direction of the pin, so that outputs can be configured to cause an interrupt or start a timer.

A total of 32 combined DIO pins is available for the 71M6545T/HT. These pins can be categorized as follows:

18 DIO pins:

- DIO4...DIO5 (2 pins)
- DIO9...DIO14 (6 pins)
- DIO19...DIO25 (7 pins)
- DIO28...DIO29 (2 pins)
- DIO55 (1 pin)

9 DIO pins shared with other functions:

- DIO0/WPULSE, DIO1/VPULSE (2 pins)

- DIO2/SDCK, DIO3/SDATA (2 pins)
- DIO6/XPULSE, DIO7/YPULSE (2 pins)
- DIO8/DI (1 pin)
- DIO26, DIO27 (2 pins)

9 dedicated pins are available:

- SPI interface pins: SPI_CSZ, SPI_DO, SPI_DI, SPI_CK1 (4 pins)
- ICE Interface pins: E_RXTX, E_TCLK, E_RST (3 pins)
- Test Port pins: TMUX2OUT, TMUXOUT (2 pins)

EEPROM Interface

The 71M654xT provides hardware support for both two-pin (I²C) and three-wire (MICROWIRE) EEPROMs.

Two-Pin EEPROM Interface

The two-pin serial interface is multiplexed onto the DIO2 (SDCK) and DIO3 (SDATA) pins. Configure the interface for two-pin mode by setting DIO_EEX[1:0] = 01. The MPU communicates with the interface through the SFR registers EEDATA and EECTRL. To write a byte of data to the EEPROM the MPU places the data in EEDATA and then writes the Transmit code to EECTRL. This initiates the transmit operation which is finished when the BUSY bit falls. INT5 is also asserted when BUSY falls. The MPU can then check the RX_ACK bit to see if the EEPROM acknowledged the transmission.

A byte is read by writing the Receive command to EECTRL and waiting for the BUSY bit to fall. Upon completion, the received data is in EEDATA. The serial transmit and receive clock is 78kHz during each transmission, and then holds in a high state until the next transmission.

The two-pin interface handles protocol details. The MPU can command the interface to issue a start, a repeated start and a stop condition, and it can manage the transmitted ACK status as well.

Three-Wire EEPROM Interface

The three-wire interface supports standard MICROWIRE (single data pin with clock and select pins) or a subset of SPI (separate DI and DO pins with clock and select pins). MICROWIRE is selected by setting DIO_EEX[1:0] = 10. In this mode, EECTRL selects whether the interface is sending or receiving, and eight bits of data are transferred in each transaction. In this configuration, DIO2 is configured for clock, and DIO3 is configured for data.

When separate DI/DO pins are selected (DIO_EEX[1:0] = 11) the interface operates as a subset of SPI. Only SPI modes 0 or 3 are supported. In this configuration, DIO3 is DO and DIO8 is DI.

UART

The 71M6545T/HT includes a UART (UART0) that can be programmed to communicate with a variety of AMR modules and other external devices.

SPI Slave Port

The SPI slave port communicates directly with the MPU data bus and is able to read and write Data RAM and I/O RAM locations. It is also able to send commands to the MPU. The interface to the slave port consists of the SPI_CSZ, SPI_CKI, SPI_DI and SPI_DO pins.

Additionally, the SPI interface allows flash memory to be read and to be programmed. To facilitate flash programming, cycling power or asserting RESET causes the SPI port pins to default to SPI mode. The SPI port is disabled by clearing the SPI_E bit.

Possible applications for the SPI interface are:

- An external host reads data from CE locations to obtain metering information. This can be used in applications where the 71M654xT function as a smart front-end with preprocessing capability. Since the addresses are in 16-bit format, any type of XRAM data can be accessed: CE, MPU, I/O RAM, but not SFRs or the 80515-internal register bank.
- A communication link can be established via the SPI interface: By writing into MPU memory locations, the external host can initiate and control processes in the 71M654xT MPU. Writing to a CE or MPU location normally generates an interrupt, a function that can be used to signal to the MPU that the byte that had just been written by the external host must be read and processed. Data can also be inserted by the external host without generating an interrupt.
- An external DSP can access front-end data generated by the ADC. This mode of operation uses the 71M654xT as an analog front-end (AFE).
- Flash programming by the external host (SPI Flash Mode).

SPI Safe Mode

Sometimes it is desirable to prevent the SPI interface from writing to arbitrary RAM locations and thus disturbing MPU and CE operation. This is especially true in AFE applications. For this reason, the SPI SAFE mode was created. In SPI SAFE mode, SPI write operations are disabled except for a 16 byte transfer region at address 0x400 to 0x40F. If the SPI host needs to write to other addresses, it must use the SPI_CMD register to request the write operation from the MPU. SPI SAFE mode is enabled by the SPI_SAFE bit.

SPI Flash Mode (SFM)

In normal operation, the SPI slave interface cannot read or write the flash memory. However, the 71M6545T/HT supports an SPI Flash Mode (SFM) which facilitates initial programming of the flash memory. When in SFM mode, the SPI can erase, read, and write the flash memory. Other memory elements such as XRAM and I/O RAM are not accessible in this mode. In order to protect the flash contents, several operations are required before the SFM mode is successfully invoked.

In SFM mode, n byte reads and dual-byte writes to flash memory are supported. Since the flash write operation is always based on a two-byte word, the initial address must always be even. Data is written to the 16-bit flash memory bus after the odd word is written.

In SFM mode, the MPU is completely halted. The 71M6545T/HT must be reset by the WD timer or by the RESET pin in order to exit SFM mode.

If the SPI port is used for code updates (in lieu of a programmer that uses the ICE port), then a code that disables the flash access through SPI can potentially lock out flash program updates.

Hardware Watchdog Timer

An independent, robust, fixed-duration, watchdog timer (WDT) is included in the 71M6545T/HT. It uses the RTC crystal oscillator as its time base and must be refreshed by the MPU firmware at least every 1.5 seconds. When not refreshed on time, the WDT overflows and the part is reset as if the RESET pin were pulled high, except that the I/O RAM bits are in the same state as after a wake-up from SLP or LCD modes. After 4100 CK32 cycles (or 125 ms) following the WDT overflow, the MPU is launched from program address 0x0000.

The watchdog timer is also reset when the internal signal WAKE = 0.

Test Ports

Two independent multiplexers allow the selection of internal analog and digital signals for the TMUXOUT and TMUX2OUT pins ([Table 10](#)).

The TMUXOUT and TMUX2OUT pins may be used for diagnostics purposes during the product development cycle or in the production test. The RTC 1-second output may be used to calibrate the crystal oscillator. The RTC 4-second output provides higher precision for RTC calibration. RTCLK may also be used to calibrate the RTC.

Table 10. Test Ports

TMUX[5:0]	SIGNAL NAME	DESCRIPTION
1	RTCLK	32.768 kHz clock waveform
9	WD_RST	Indicates when the MPU has reset the watchdog timer. Can be monitored to determine spare time in the watchdog timer.
A	CKMPU	MPU clock
D	V3AOK bit	Indicates that the V3P3A pin voltage is ≥ 3.0 V. The V3P3A and V3P3SYS pins are expected to be tied together at the PCB level. The 71M6543 monitors the V3P3A pin voltage only.
E	V3OK bit	Indicates that the V3P3A pin voltage is ≥ 2.8 V. The V3P3A and V3P3SYS pins are expected to be tied together at the PCB level. The 71M654 monitors the V3P3A pin voltage only.
1B	MUX_SYNC	Internal multiplexer frame SYNC signal.
1C	CE_BUSY interrupt	
1D	CE_XFER interrupt	
1F	RTM output from CE	

Note: All TMUX[5:0] values that are not shown are reserved.

TMUX2[4:0]	SIGNAL NAME	DESCRIPTION
0	WD_OVF	Indicates when the watchdog timer has expired (overflowed).
1	PULSE_1S	One-second pulse with 25% duty cycle. This signal can be used to measure the deviation of the RTC from an ideal 1-second interval. Multiple cycles should be averaged together to filter out jitter.
2	PULSE_4S	Four-second pulse with 25% duty cycle. This signal can be used to measure the deviation of the RTC from an ideal 4-second interval. Multiple cycles should be averaged together to filter out jitter. This pulse provides a more precise measurement than the 1-second pulse.
3	RTCLK	32.768 kHz clock waveform
8	SPARE[1] bit – I/O RAM 0x2704[1]	Copies the value of the bit stored in 0x2704[1]. For general purpose use.
9	SPARE[2] bit – I/O RAM 0x2704[2]	Copies the value of the bit stored in 0x2704[2]. For general purpose use.
A	WAKE	Indicates when a WAKE event has occurred.
B	MUX_SYNC	Internal multiplexer frame SYNC signal.
C	MCK	
E	GNDD	Digital GND. Use this signal to make the TMUX2OUT pin static.

Table 10. Test Ports (continued)

TMUX[5:0]	SIGNAL NAME	DESCRIPTION
1	RTCLK	32.768 kHz clock waveform
12	INT0 – DIG I/O	Interrupts
13	INT1 – DIG I/O	
14	INT2 – CE_PULSE	
15	INT3 – CE_BUSY	
16	INT4 - VSTAT	
17	INT5 – EEPROM/SPI	
18	INT6 – XFER, RTC	
1F	RTM_CK (flash)	

Note: All TMUX2[4:0] values which are not shown are reserved.

Functional Description

Theory of Operation

The energy delivered by a power source into a load can be expressed as:

$$E = \int_0^t V(t)I(t)dt$$

Assuming phase angles are constant, the following formulae apply:

- $P = \text{Real Energy [Wh]} = V \times A \times \cos(\phi) \times t$
- $Q = \text{Reactive Energy [VARh]} = V \times A \times \sin(\phi) \times t$
- $S = \text{Apparent Energy [VAh]} = \sqrt{P^2 + Q^2}$

For a practical meter, not only voltage and current amplitudes, but also phase angles and harmonic content may change constantly. Thus, simple RMS measurements are inherently inaccurate. The 71M654xT, however, functions by emulating the integral operation above by processing current and voltage samples at a constant rate. As long as the ADC resolution is high enough and the sample frequency is beyond the harmonic range of interest, the current and voltage samples, multiplied by the sample period yield an accurate value for the instantaneous energy. Summing the instantaneous energy quantities over time provides accurate results for accumulated energy.

The application of 240V AC and 100A results in an accumulation of 480Ws (= 0.133 Wh) over the 20ms period, as indicated by the accumulated power curve. The described sampling method works reliably, even in the presence of dynamic phase shift and harmonic distortion.

Battery Modes

The 71M654xT can operate in one of three power modes: mission (MSN), brownout (BRN), or sleep (SLP).

Shortly after system power ($V_{V3P3SYS}$) is applied, the part is in mission mode. MSN mode means that the part is operating with system power and that the internal PLL is stable. This mode is the normal operating mode where the part is capable of measuring energy.

When system power is not available, the 71M654xT is in one of three battery modes: BRN or SLP.

An internal comparator monitors the voltage at the V_{V3P3A} pin (note that $V_{V3P3SYS}$ and V_{V3P3A} are typically connected together at the PCB level). When the V_{V3P3A} DC voltage drops below 2.8 VDC, the comparator resets an internal power status bit called V3OK. As soon as system power is removed and V3OK = 0, the 71M654xT switches to battery power (V_{BAT} pin), notifies the MPU by issuing an interrupt and updates the VSTAT[2:0] register. The MPU continues to execute code when the system transitions from MSN to BRN mode. Depending on the MPU code, the MPU can choose to stay in BRN mode, or transition to SLP mode. BRN mode is similar to MSN mode except that resources powered by V_{V3P3A} power, such as the ADC are inaccurate. In BRN mode the CE continues to run and should be turned off to conserve V_{BAT} power. Also, the PLL continues to function at the same frequency as in MSN mode and its frequency should be reduced to save power.

When system power is restored, the 71M654xT automatically transitions from any of the battery modes (BRN, LCD, SLP) back to MSN mode, switches back to using system power ($V_{V3P3SYS}$, V_{V3P3A}), issues an interrupt and updates VSTAT[1:0]. The MPU software should restore MSN mode operation by issuing a soft reset to restore system settings to values appropriate for MSN mode.

Transitions from SLP mode to BRN mode can be initiated by the following events:

- 1) Wake-up timer timeout.
- 2) Pushbutton (PB) is activated.
- 3) A rising edge on DIO4 or DIO55.
- 4) Activity on the RX or OPT_RX pins.

Brownout Mode

In BRN mode, most nonmetering digital functions are active including ICE, UART, EEPROM, and RTC. In BRN mode, the PLL continues to function at the same frequency as MSN mode. It is up to the MPU to reduce the PLL frequency or the MPU frequency in order to minimize power consumption.

From BRN mode, the MPU can choose to enter SLP mode. When system power is restored while the 71M654xT is in BRN mode, the part automatically transitions to MSN mode.

Sleep Mode

When the $V_{V3P3SYS}$ pin voltage drops below 2.8 VDC, the 71M654xT enters BRN mode and the V_{V3P3D} pin obtains power from the V_{BAT} pin instead of the $V_{V3P3SYS}$ pin. Once in BRN mode, the MPU may invoke SLP mode by setting the SLEEP bit. The purpose of SLP mode is to consume the least amount power while still maintaining the real time clock, temperature compensation of the RTC, and the nonvolatile portions of the I/O RAM.

In SLP mode, the V_{V3P3D} pin is disconnected, removing all sources of current leakage from the V_{BAT} pin. The nonvolatile I/O RAM locations and the SLP mode functions,

such as the temperature sensor, oscillator, RTC, and the RTC temperature compensation are powered by the V_{BAT_RTC} pin. SLP mode can be exited only by a system power-up event or one of the wake methods.

If the SLEEP bit is asserted when $V_{V3P3SYS}$ pin power is present (i.e., while in MSN mode), the 71M654xT enters SLP mode, resetting the internal WAKE signal, at which point the 71M654xT begins the standard wake from sleep procedures.

When power is restored to the $V_{V3P3SYS}$ pin, the 71M654xT transitions from SLP mode to MSN mode and the MPU PC (Program Counter) is initialized to 0x0000. At this point, the XRAM is in an undefined state, but nonvolatile I/O RAM locations are preserved.

Applications Information

Connecting 5V Devices

All digital input pins of the 71M654xT are compatible with external 5V devices. I/O pins configured as inputs do not require current-limiting resistors when they are connected to external 5V devices.

Direct Connection of Sensors

The 71M654xT supports direct connection of current transformer and shunt-fed sensors.

Using the 71M6545T/HT with Local Sensors

The 71M6545T/HT can be configured to operate with locally connected current sensors. All current inputs are connected to a current transformer (CT) and are therefore isolated. This configuration implements a polyphase

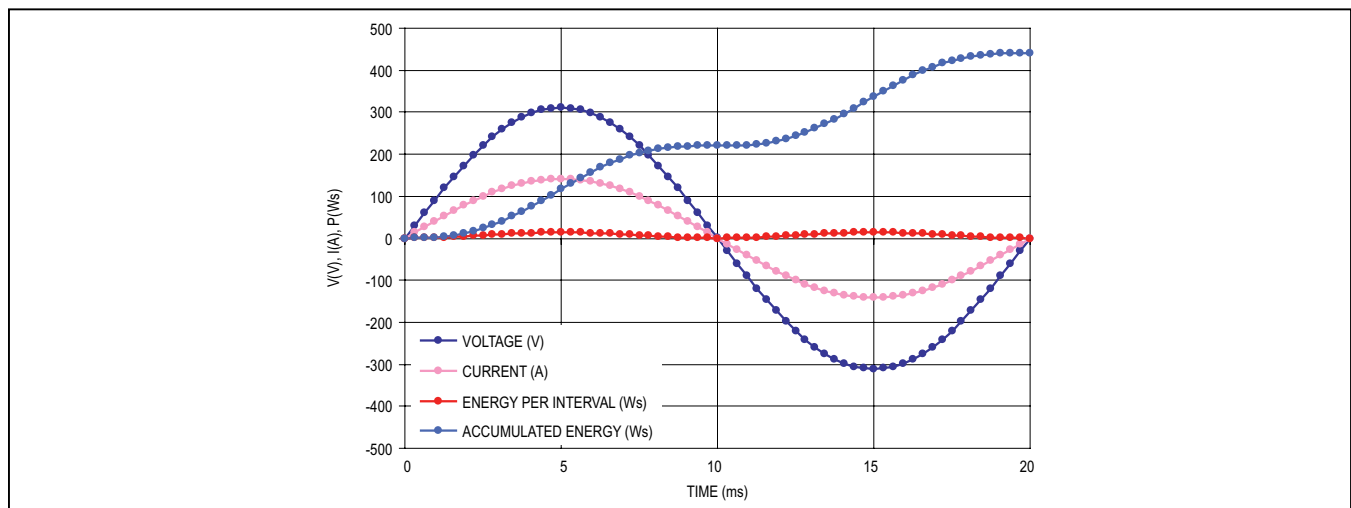

Figure 6. Waveforms Comparing Voltage, Current, Energy per Interval, and Accumulated Energy

measurement with tamper-detection using one current sensor to measure the neutral current. For best performance, all current sensor inputs are configured for differential mode.

Using the 71M6545T/HT with Remote Sensors

The 71M6545T/HT can be configured to operate with 71M6x03 remote sensor interfaces and current shunts. This configuration implements a polyphase measurement with tamper-detection. For best performance, the IADC0-IADC1 current sensor input is configured for differential mode (DIFFA_E = 1). The outputs of the 71M6x03 isolated sensor interface are routed through a pulse transformer, which is connected to the current input pins (IADC2-IADC7). The current input pins (IADC2-IADC7) must be configured for remote sensor communication (i.e., RMT_E = 1).

Metrology Temperature Compensation

Since the V_{REF} bandgap amplifier is chopper-stabilized the DC offset voltage (the most significant long-term drift mechanism in bandgap voltage references) is automatically removed by the chopper circuit. Both the 71M654xT and the 71M6x03 feature chopper circuits for their respective V_{REF} voltage reference. V_{REF} is trimmed to a target value of 1.195V during the device manufacturing process and the result of the trim stored in nonvolatile fuses.

For the 71M654xT device (Q0.5% energy accuracy), the TRIMT[7:0] value can be read by the MPU during initialization in order to calculate parabolic temperature compensation coefficients suitable for each individual 71M654xT device. The resulting temperature coefficient for V_{REF} in the 71M654xT is ± 40 ppm/°C.

By using the trim information in the TRIMT register and the sensed temperature, a gain adjustment for the sensor can be computed. See the *71M6545T/HT User's Guide* for more information about compensating sensors for temperature variations.

Connecting I²C EEPROMs

I²C EEPROMs or other I²C compatible devices should be connected to the DIO pins DIO2 and DIO3.

Pullup resistors of roughly 10k Ω to V_{V3P3D} (to ensure operation in BRN mode) should be used for both SDCK and SDATA signals. The DIO_EEX[1:0] field in I/O RAM must be set to 01 in order to convert the DIO pins DIO2 and DIO3 to I²C pins SDCK and SDATA.

Connecting Three-Wire EEPROMs

MICROWIRE EEPROMs and other compatible devices should be connected to the DIO pins DIO2/SDCK and DIO3/SDATA.

UART

The UART0 RX pin should be pulled down by a 10k Ω resistor and additionally protected by a 100pF ceramic capacitor.

With modulation, an optical emitter can be operated at higher current than nominal, enabling it to increase the distance along the optical path.

If operation in BRN mode is desired, the external components should be connected to V_{V3P3D} . However, it is recommended to limit the current to a few mA.

Reset

Even though a functional meter does not necessarily need a reset switch, it is useful to have a reset push-button for prototyping. The RESET signal may be sourced from $V_{V3P3SYS}$ (functional in MSN mode only), V_{V3P3D} (MSN and BRN modes), or V_{BAT} (all modes, if a battery is present), or from a combination of these sources, depending on the application. RESET causes the CPU to restart and returns all IO RAM values to their default values.

For a production meter, the RESET pin should be protected by the external components. R1 should be in the range of 100 Ω and mounted as closely as possible to the IC.

Emulator Port Pins

Even when the emulator is not used, small shunt capacitors to ground (22pF) should be used for protection from EMI. Production boards should have the ICE_E pin connected to ground.

MPU Firmware Library

All application-specific MPU functions are featured in the demonstration C source code supplied by Maxim Integrated. The code is available as part of the Demonstration Kit for the 71M6545T/HT. The Demonstration Kits come with pre-programmed with demo firmware and mounted on a functional sample meter Demo Board. The Demo Boards allow for quick and efficient evaluation of the IC without having to write firmware or having to supply an in-circuit emulator (ICE). Contact Maxim Integrated for information on price and availability of demonstration boards.

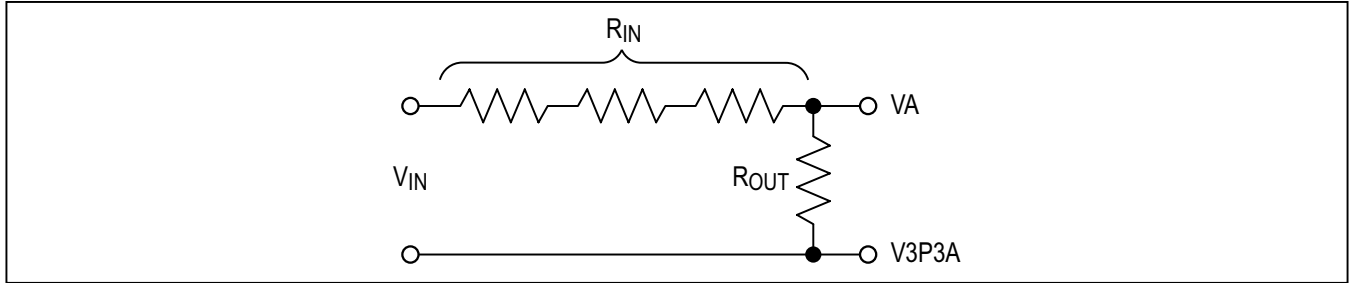

Figure 7. Typical Voltage Sense Circuit Using Resistive Divider

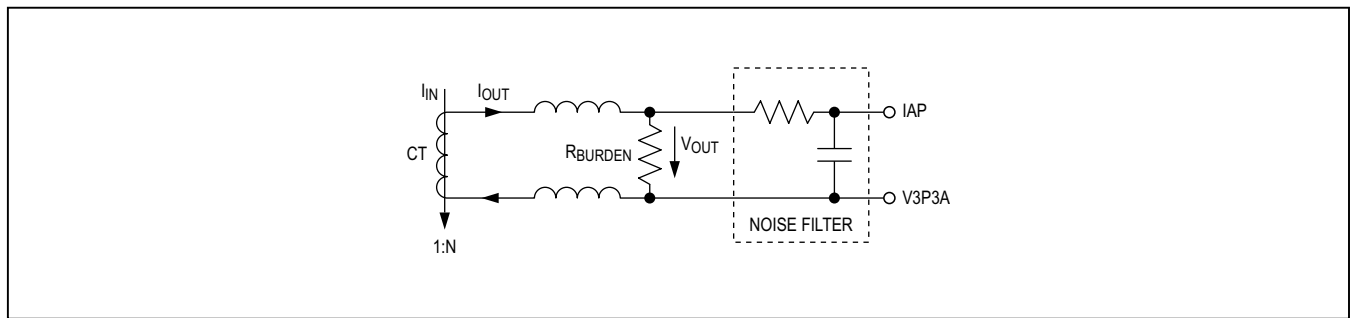

Figure 8. Typical Current-Sense Circuit Using Current Transformer in a Single-Ended Configuration

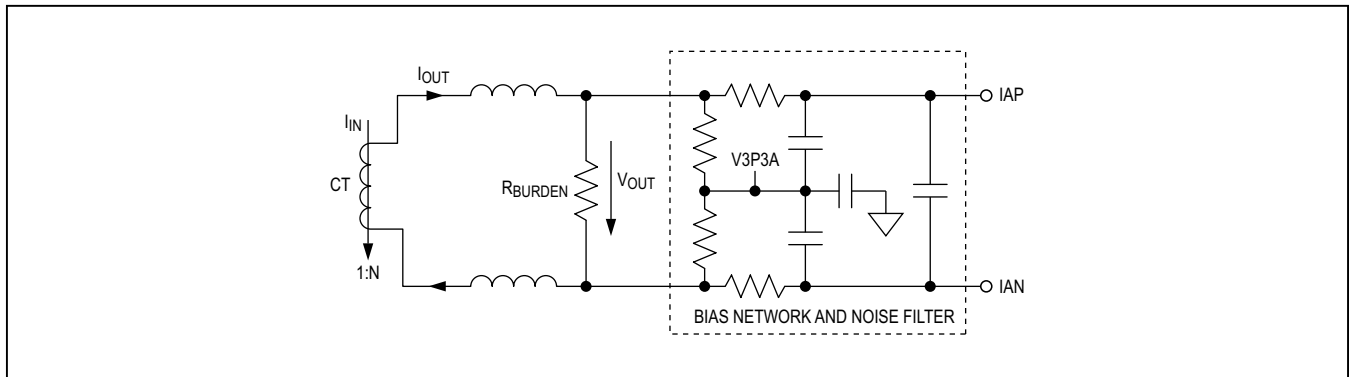

Figure 9. Typical Current-Sense Circuit Using Current Transformer in a Differential Configuration

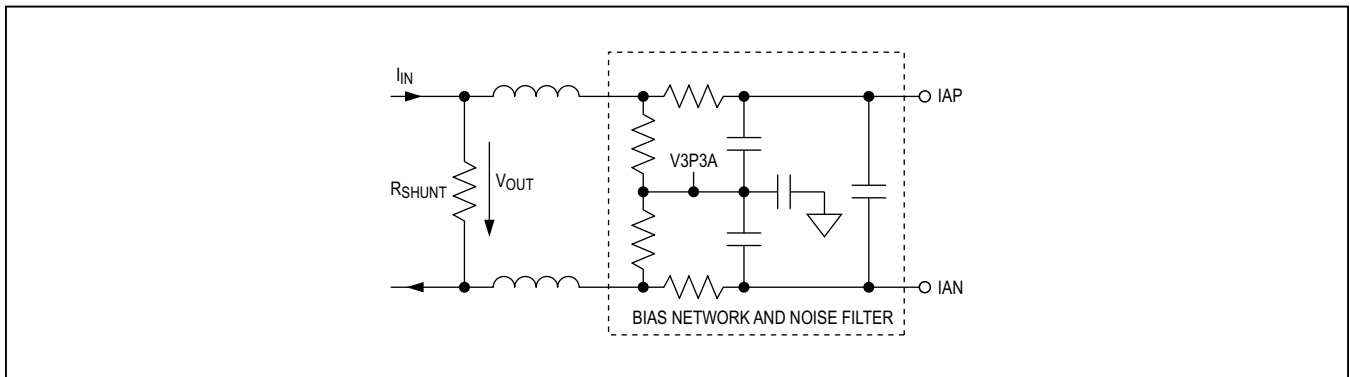

Figure 10. Typical Current-Sense Circuit Using Shunt in a Differential Configuration

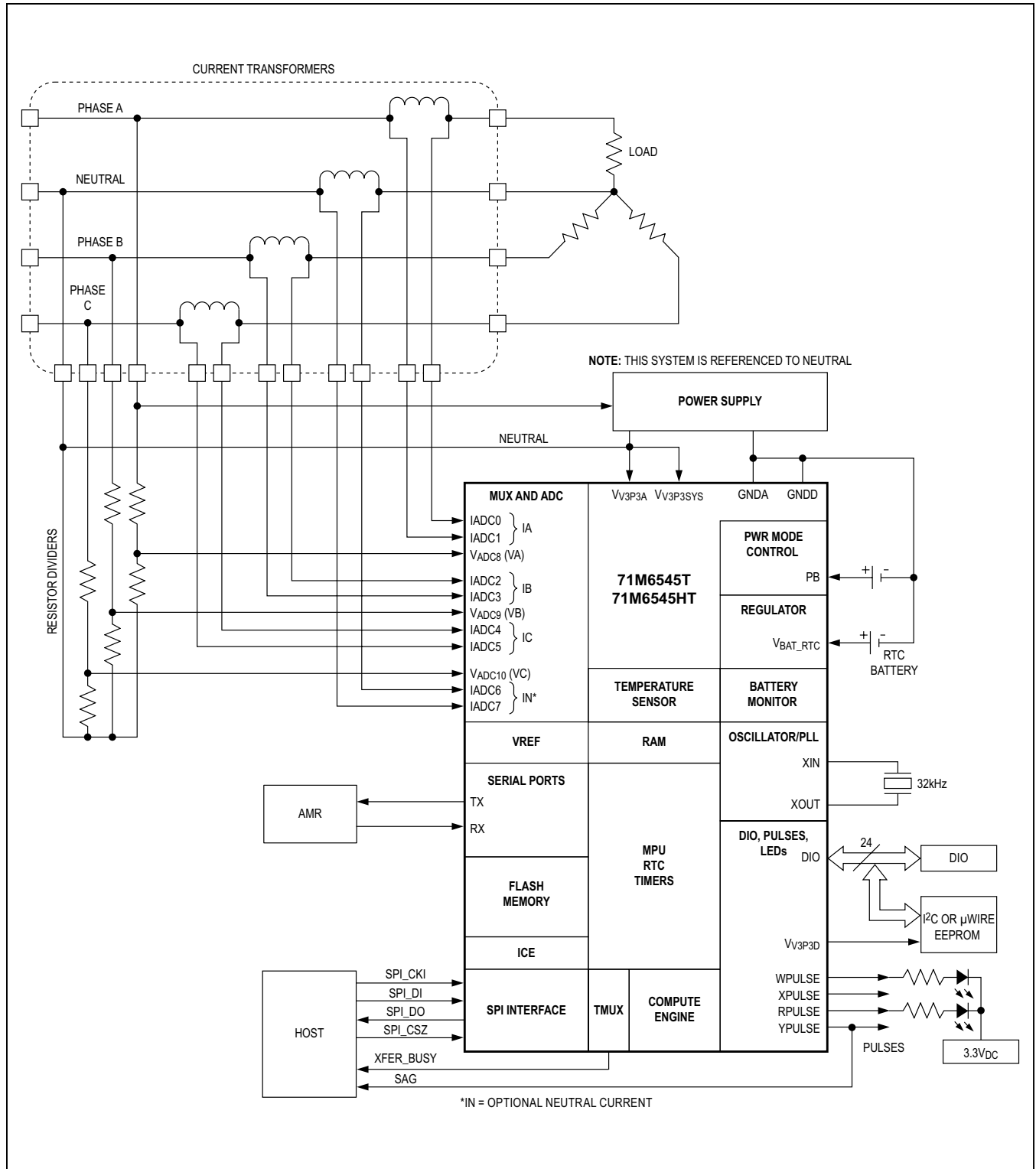

Figure 11. 71M6545T/HT Typical Operating Circuit Using Locally Connected Sensors

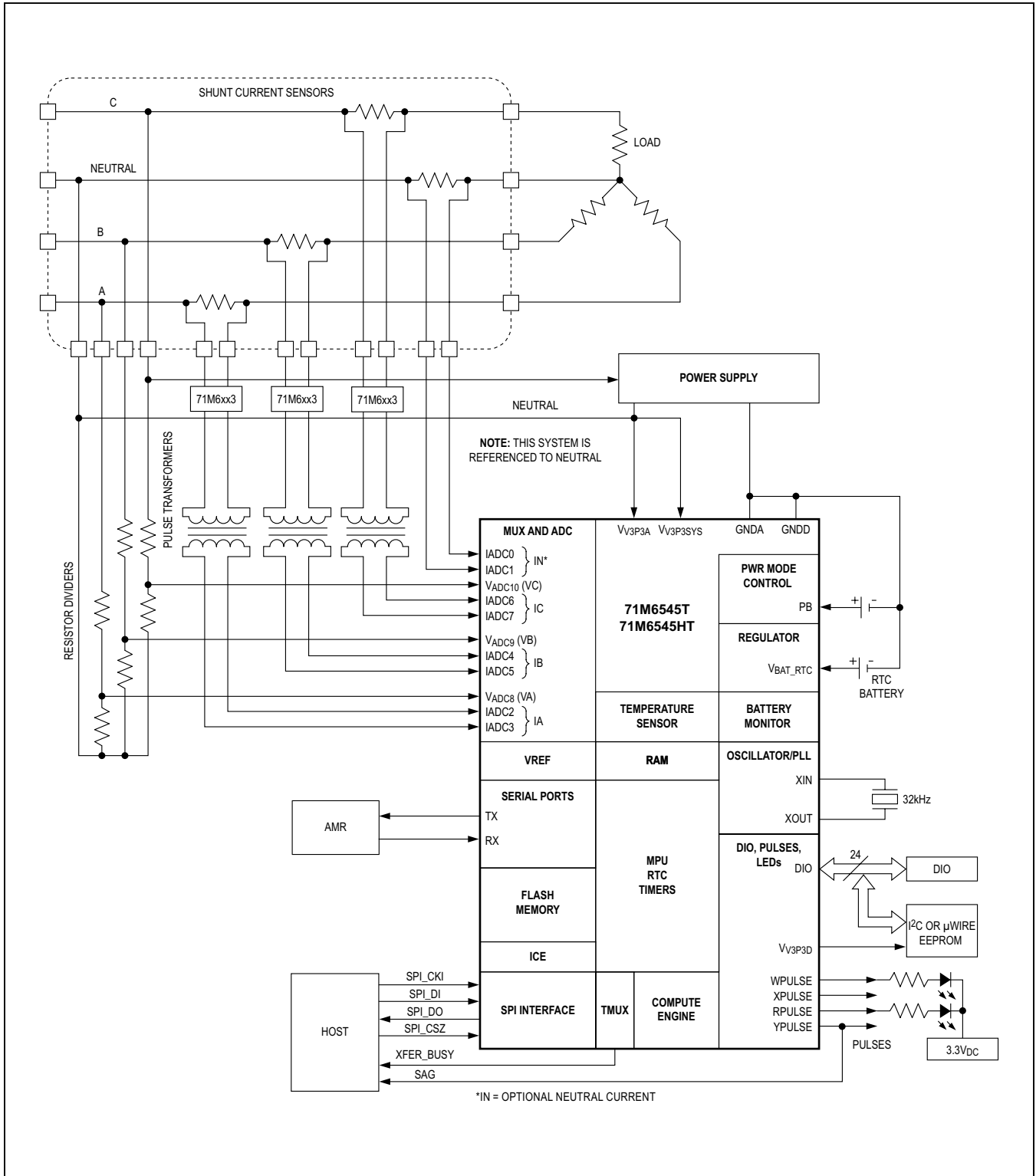

Figure 12. 71M6545T/HT Typical Operating Circuit Using Remote Neutral Current Sensor

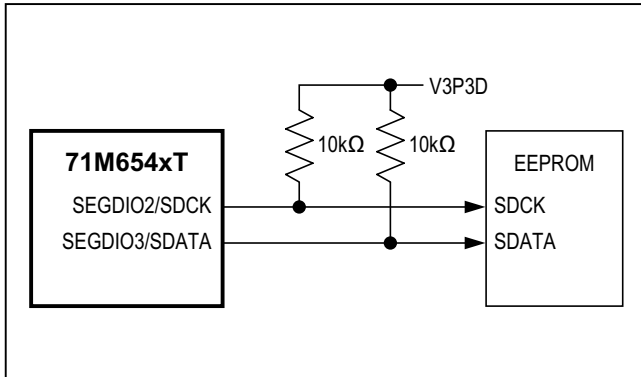

Figure 13. Typical I²C Operating Circuit

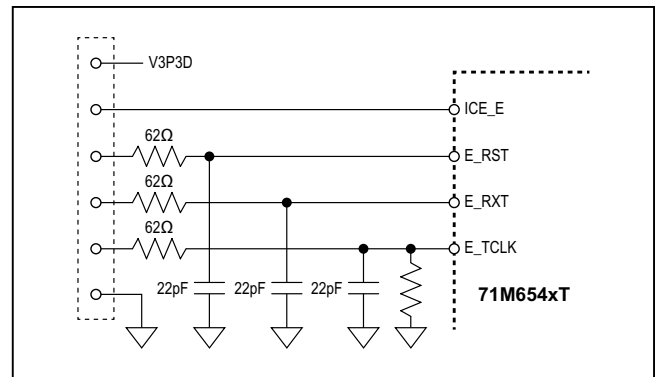

Figure 16. Typical Emulator Connections

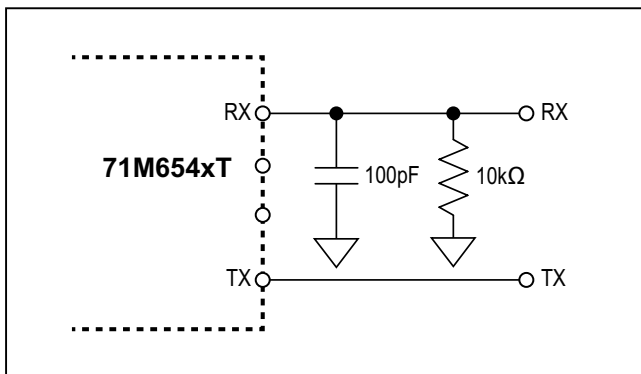

Figure 14. Typical UART Operating Circuit

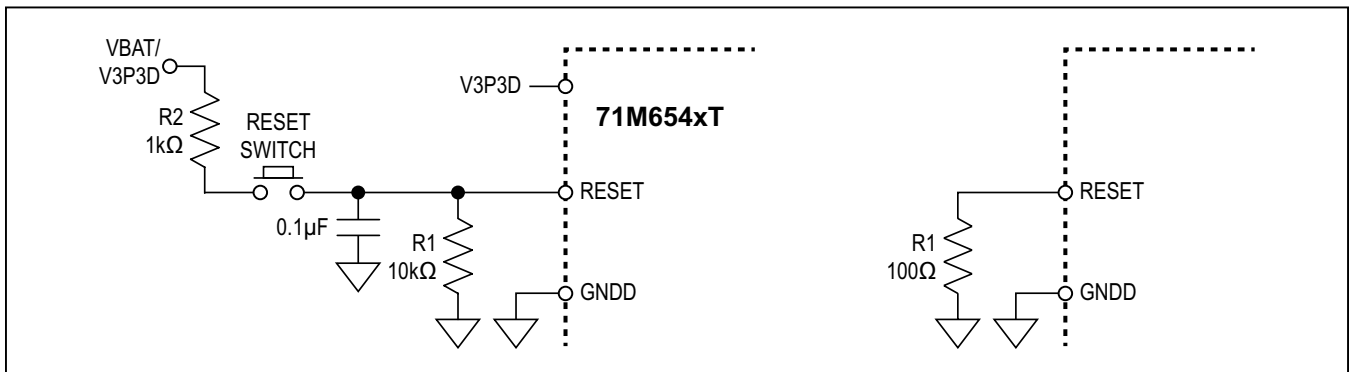

Figure 15. Typical Reset Circuits

Meter Calibration

Once the 71M654xT energy meter device has been installed in a meter system, it must be calibrated. A complete calibration includes:

- Establishment of the reference temperature (typically 22°C).
- Calibration of the metrology section: calibration for tolerances of the current sensors, voltage dividers and signal conditioning components as well as of the internal reference voltage (V_{REF}) at the reference temperature.

The metrology section can be calibrated using the gain and phase adjustment factors accessible to the CE. The gain adjustment is used to compensate for tolerances of components used for signal conditioning, especially the resistive components. Phase adjustment is provided to compensate for phase shifts introduced by the current sensors or by the effects of reactive power supplies.

Due to the flexibility of the MPU firmware, any calibration method, such as calibration based on energy, or current and voltage can be implemented. It is also possible to implement segment-wise calibration (depending on current range).

The 71M6545T/HT support common industry standard calibration techniques, such as single-point (energy-only), multipoint (energy, V_{RMS} , I_{RMS}), and auto-calibration.

Contact Maxim Integrated to obtain a copy of the latest calibration spreadsheet file for the 71M654xT.

Firmware Interface

Overview: Functional Order

The I/O RAM locations at addresses 0x2000 to 0x20FF have sequential addresses to facilitate reading by the MPU. These I/O RAM locations are usually modified only at power-up. These addresses are an alternative sequential address to subsequent addresses (above 0x2100). For instance, EQU[2:0] can be accessed at I/O RAM 0x2000[7:5] or at I/O RAM 0x2106[7:5].

Unimplemented (U) and reserved (R) bits are shaded in light gray. Unimplemented bits are identified with a 'U'.

Unimplemented bits have no memory storage, writing them has no effect, and reading them always returns zero.

Reserved bits are identified with an 'R', and must always be written with a zero. Writing values other than zero to reserved bits may have undesirable side effects and must be avoided.

Nonvolatile bits are shaded in dark gray. Nonvolatile bits are backed up during power failures if the system includes a battery connected to the V_{BAT} pin.

I/O RAM Map: Details

Writable bits are written by the MPU into configuration RAM. Typically, they are initially stored in flash memory and copied to the configuration RAM by the MPU. Some of the more frequently programmed bits are mapped to the MPU SFR memory space. The remaining bits are mapped to the address space 0x2XXX. The RST and WK columns describe the bit values upon reset and wake, respectively. No entry in one of these columns means the bit is either read-only or is powered by the NV supply and is not initialized. Write-only bits return zero when they are read.

Locations that are shaded in grey are nonvolatile (i.e., battery-backed).

Reading the Info Page

Information useful for calibrating the temperature sensor and other functions is available in trim fuses. The trim fuse values provided in the 71M654xT devices cannot be directly accessed through the I/O RAM space. They reside in a special area termed the Info Page. The MPU gains access to the Info Page by setting the INFO_PG (I/O RAM 0x270B[0]) control bit. Once this bit is set, Info Page contents are accessible in program memory space starting at the address specified by the contents of CE_LCTN[6:0] (71M654xGT) or CE_LCTN[5:0] (71M654xFT) (I/O RAM 0x2109[6:0] for 71M654xGT or 0x2109[5:0] for 71M654xFT). These pointers specify a base address at a 1KB address boundary which is at 1024 x CE_LCTN[6:0] (71M654xGT) or CE_LCTN[5:0] (71M654xFT). [Table 11](#) provides a list of the available trim fuses and their corre-

Table 11. Info Page Trim Fuses

REGISTER NAME	DEFINITION	LOCATION	ADDRESS	FORMAT	TYPICAL VALUE
STEMP_T85_P	STEMP at +85C	Info Block	0xAA, 0xAB	16 bits, signed	4400
STEMP_T22_P	STEMP at +22C	Info Block	0x8A, 0x8B	13 bits, unsigned	3600
T85_P	Probe temperature at +85C	Info Block	0xA6, 0xA7	16 bits signed	605
T22_P	Probe temperature at +22C	Info Block	0x9A	8 bits signed	35
STEMP	Temperature sensor	I/O RAM	0x2882, 0x2882	11 bits, sign extended	

sponding offsets relative to the Info Page base address. After reading the desired Info Page information, the MPU must reset the INFO_PG bit. The code below provides an example for reading Info Page fuse trims. In this code example, the address, px is a pointer to the MPU's code space. In assembly language, the Info Page data objects, which are read-only, must be accessed with the MOVC 8051 instruction. In the C-language, Info Page trim fuses must be fetched with a pointer of the correct width, depending on the format of the trim fuse (an 8-bit or a 16-bit data object). The case statements in the code example below perform casts to obtain a pointer of the correct size for each object, as needed.

In assembly language, the MPU has to form 11-bit or 16-bit values from two separate 8-bit fetches, depending on the object being fetched. The byte values containing less than 8 valid bits are LSB justified. For example Info Page offset 0x90 is an 8-bit object whose three LSBs are bits [10:8] of the complete TEMP_85[10:0] 11-bit object. The Info Page data objects are 2s complement format and should be sign-extended when read into a 16-bit data type (see case _TEMP85 in the code example).

```
#if HIGH_PRECISION_METER
int16_t read_trim (enum eTRIMSEL
select) {
    uint8r_t *px;
    int16_t x;
    px = ((uint16_t)select) +
((uint8r_t *) (CE3 << 10));
    switch (select)
    {
    default:
    case _TRIMBGD:
        INFO_PG = 1;
        x = *px;
        INFO_PG = 0;
        break;
    case _TRIMBGB:
        INFO_PG = 1;
        x = *(uint16r_t*)px;
        INFO_PG = 0;
        break;
    case _TEMP85:
        INFO_PG = 1;
        x = *(uint16r_t*)px;
        INFO_PG = 0;
        if (x & 0x800) x |= 0xF800;
        break;
    }
    return (x); }
#endif // #if HIGH_PRECISION_METER
```

Table 12. I/O RAM Locations in Numerical Order

NAME	ADDR	BIT 7	BIT 6	BIT 5	BIT 4	BIT 3	BIT 2	BIT 1	BIT 0	
CE6	2000	EQU[2:0]			U	CHOP_E[1:0]		RTM_E	CE_E	
CE5	2001	U	U	U	SUM_SAMPS[12:8]					
CE4	2002	SUM_SAMPS[7:0]								
CE3	2003	U	U	CE_LCTN[5:0]						
CE2	2004	PLS_MAXWIDTH[7:0]								
CE1	2005	PLS_INTERVAL[7:0]								
CE0	2006	DIFF6_E	DIFF4_E	DIFF2_E	DIFF0_E	RFLY_DIS	FIR_LEN[1:0]		PLS_INV	
RCE0	2007	CHOPR[1:0]		RMT6_E	RMT4_E	RMT2_E	R	R	R	
RTMUX	2008	U	TMUXRB[2:0]			U	TMUXRA[2:0]			
Reserved	2009	U	U	R	U	U	U	U	U	
MUX5	200A	MUX_DIV[3:0]				MUX10_SEL				
MUX4	200B	MUX9_SEL				MUX8_SEL				
MUX3	200C	MUX7_SEL				MUX6_SEL				
MUX2	200D	MUX5_SEL				MUX4_SEL				
MUX1	200E	MUX3_SEL				MUX2_SEL				
MUX0	200F	MUX1_SEL				MUX0_SEL				
TEMP	2010	TEMP_BSEL	TEMP_PWR	OSC_COMP	TEMP_BAT	U	TEMP_PER[2:0]			
DIO_R5	201B	U	U	U	U	U	DIO_RPB[2:0]			
DIO_R4	201C	U	DIO_R11[2:0]			U	DIO_R10[2:0]			
DIO_R3	201D	U	DIO_R9[2:0]			U	DIO_R8[2:0]			
DIO_R2	201E	U	DIO_R7[2:0]			U	DIO_R6[2:0]			
DIO_R1	201F	U	DIO_R5[2:0]			U	DIO_R4[2:0]			
DIO_R0	2020	U	DIO_R3[2:0]			U	DIO_R2[2:0]			
DIO0	2021	DIO_EEX[1:0]		U	U	OPT_TXE[1:0]		OPT_TXMOD	OPT_TXINV	
DIO1	2022	DIO_PW	DIO_PV	OPT_FDC[1:0]		U	OPT_RXDIS	OPT_RXINV	OPT_BB	
DIO2	2023	DIO_PX	DIO_PY	U	U	U	U	U	U	
INT1_E	2024	EX_EEX	EX_XPULSE	EX_YPULSE	EX_RTCT	EX_TCTEMP	EX_RTC1M	EX_RTC1S	EX_XFER	
INT2_E	2025	EX_SPI	EX_WPULSE	EX_VPULSE						
WAKE_E	2026	U	EW_TEMP	U	EW_RX	EW_PB	EW_DIO4	U	EW_DIO55	
SFMM	2080	SFMM[7:0] (via SPI slave port only)								
SFMS	2081	SFMS[7:0] (via SPI slave port only)								
CE AND ADC										
MUX5	2100	MUX_DIV[3:0]				MUX10_SEL[3:0]				
MUX4	2101	MUX9_SEL[3:0]				MUX8_SEL[3:0]				
MUX3	2102	MUX7_SEL[3:0]				MUX6_SEL[3:0]				
MUX2	2103	MUX5_SEL[3:0]				MUX4_SEL[3:0]				
MUX1	2104	MUX3_SEL[3:0]				MUX2_SEL[3:0]				
MUX0	2105	MUX1_SEL[3:0]				MUX0_SEL[3:0]				
CE6	2106	EQU[2:0]			U	CHOP_E[1:0]		RTM_E	CE_E	
CE5	2107	U	U	U	SUM_SAMPS[12:8]					
CE4	2108	SUM_SAMPS[7:0]								
CE3	2109	U	U	CE_LCTN[5:0]						
CE2	210A	PLS_MAXWIDTH[7:0]								

Table 12. I/O RAM Locations in Numerical Order (continued)

NAME	ADDR	BIT 7	BIT 6	BIT 5	BIT 4	BIT 3	BIT 2	BIT 1	BIT 0
CE1	210B	PLS_INTERVAL[7:0]							
CE0	210C	R	R	DIFFB_E	DIFFA_E	RFLY_DIS	FIR_LEN[1:0]	PLS_INV	CE0
RTM0	210D	U	U	U	U	U	U	RTM0[9:8]	
RTM0	210E	RTM0[7:0]							
RTM1	210F	RTM1[7:0]							
RTM2	2110	RTM2[7:0]							
RTM3	2111	RTM3[7:0]							
FIR_EXT	2112	U	U	U	U	SLOT_EXT[3:0]			
CLOCK GENERATION									
CKGN	2200	OUT_SQ[1:0]		ADC_DIV	PLL_FAST	RESET	MPU_DIV[2:0]		
V_{REF} TRIM FUSES									
TRIMT	2309	TRIMT[7:0]							
DIO									
DIO_R5	2450	U	U	U	U	U	DIO_RPB[2:0]		
DIO_R4	2451	U	DIO_R11[2:0]			U	DIO_R10[2:0]		
DIO_R3	2452	U	DIO_R9[2:0]			U	DIO_R8[2:0]		
DIO_R2	2453	U	DIO_R7[2:0]			U	DIO_R6[2:0]		
DIO_R1	2454	U	DIO_R5[2:0]			U	DIO_R4[2:0]		
DIO_R0	2455	U	DIO_R3[2:0]			U	DIO_R2[2:0]		
DIO0	2456	DIO_EEX[1:0]		U	UMUX_SEL	OPT_TXE[1:0]		OPT_TXMOD	OPT_TXINV
DIO1	2457	DIO_PW	DIO_PV	OPT_FDC[1:0]		U	OPT_RXDIS	OPT_RXINV	OPT_TXINV
DIO2	2458	DIO_PX	DIO_PY	U	OUT_SQE	U	U	U	U
NONVOLATILE BITS									
TMUX	2502	U	U	TMUX[5:0]					
TMUX2	2503	U	U	U	TMUX2[4:0]				
TC_A1	2508	U	U	U	U	U	U	TC_A[9:8]	
TC_A2	2509	TC_A[7:0]							
TC_B1	250A	U	U	U	U	TC_B[11:8]			
TC_B2	250B	TC_B[7:0]							
PQMASK	2511	U	U	U	U	U	PQMASK[2:0]		
TSEL	2518	U	U	U	TEMP_SELE	TEMP_SEL[3:0]			
TSBASE1	2519	U	U	U	U	U	SBASE[10:8]		
TSBASE2	251A	SBASE[7:0]							
TSMAX	251B	U	SMAX[6:0]						
TSMIN	251C	U	SMIN[6:0]						
TSFILT	251D	U	U	U	U	SFILT[3:0]			
71M6x03 REMOTE INTERFACE									
REMOTE2	2602	RMT_RD[15:8]							
REMOTE1	2603	RMT_RD[7:0]							

Table 12. I/O RAM Locations in Numerical Order (continued)

NAME	ADDR	BIT 7	BIT 6	BIT 5	BIT 4	BIT 3	BIT 2	BIT 1	BIT 0
RBITS									
INT1_E	2700	EX_EEX	EX_XPULSE	EX_YPULSE	EX_RTCT	EX_TCTEMP	EX_RTC1M	EX_RTC1S	EX_XFER
INT2_E	2701	EX_SPI	EX_WPULSE	EX_VPULSE	U	U	U	U	U
SECURE	2702	FLSH_UNLOCK[3:0]				R	FLSH_RDE	FLSH_WRE	R
Analog0	2704	VREF_CAL	VREF_DIS	PRE_E	ADC_E	BCURR	SPARE[2:0]		
INTBITS	2707	U	INT6	INT5	INT4	INT3	INT2	INT1	INT0
FLAG0	SFR E8	IE_EEX	IE_XPULSE	IE_YPULSE	IE_RTCT	IE_TCTEMP	IE_RTC1M	IE_RTC1S	IE_XFER
FLAG1	SFR F8	IE_SPI	IE_WPULSE	IE_VPULSE	U	U	U	U	PB_STATE
STAT	SFR F9	U	U	U	PLL_OK	U	VSTAT[2:0]		
REMOTE0	SFR FC	U	PERR_RD	PERR_WR	RCMD[4:0]				
SPI1	SFR FD	SPI_CMD[7:0]							
SPI0	2708	SPI_STAT[7:0]							
RCE0	2709	CHOPR[1:0]		R	R	RMT_E	R	R	R
RTMUX	270A	U	R	R	R	U	TMUXRA[2:0]		
INFO_PG	270B	U	U	U	U	U	U	U	INFO_PG
DIO3	270C	U	U	PORT_E	SPI_E	SPI_SAFE	U	U	U
TNM1	2710	U	TEMP_NMAX[14:8]						
TNM2	2711	TEMP_NMAX[7:0]							
TM1	2712	U	U	U	U	TEMP_M[11:8]			
TM2	2713	TEMP_M[7:0]							
TNB1	2714	TEMP_NBAT[15:8]							
TNB2	2715	TEMP_NBAT[7:0]							
NV RAM AND RTC									
NVRAMxx	2800	NVRAM[0] to NVRAM[7F] - 128 bytes, direct access, 0x2800 to 0x287F							
WAKE	2880	WAKE_TMR[7:0]							
STEMP1	2881	STEMP[15:8]							
STEMP0	2882	STEMP[7:0]							
BSENSE	2885	BSENSE[7:0]							
PQ2	2886	U	U	U	PQ[20:16]				
PQ1	2887	PQ[15:8]							
PQ0	2888	PQ[7:0]							
RTC0	2890	RTC_WR	RTC_RD	U	RTC_FAIL	U	U	U	U
RTC2	2892	RTC_SBSC[7:0]							
RTC3	2893	U	U	RTC_SEC[5:0]					
RTC4	2894	U	U	RTC_MIN[5:0]					
RTC5	2895	U	U	U	RTC_HR[4:0]				
RTC6	2896	U	U	U	U	U	RTC_DAY[2:0]		
RTC7	2897	U	U	U	RTC_DATE[4:0]				
RTC8	2898	U	U	U	U	RTC_MO[3:0]			
RTC9	2899	RTC_YR[7:0]							
RTC11	289C	U	U	U	U	TC_C[11:8]			
RTC12	289D	TC_C[7:0]							

Table 12. I/O RAM Locations in Numerical Order (continued)

NAME	ADDR	BIT 7	BIT 6	BIT 5	BIT 4	BIT 3	BIT 2	BIT 1	BIT 0	
RTC13	289E	U	U	RTC_TMIN[5:0]						
RTC14	289F	U	U	U	RTC_THR[4:0]					
TEMP	28A0	TEMP_BSEL	TEMP_PWR	OSC_COMP	TEMP_BAT	TBYTE_BUSY	TEMP_PER[2:0]			
WF1	28B0	WF_CSTART	WF_RST	WF_RSTBIT	WF_OVF	WF_ERST	WF_BADVDD	U	U	
WF2	28B1	U	WF_TEMP	WF_TMR	WF_RX	WF_PB	WF_DIO4	U	WF_DIO55	
MISC	28B2	SLEEP	U	WAKE_ARM	U	U	U	U	U	
WAKE_E	28B3	U	EW_TEMP	U	EW_RX	EW_PB	EW_DIO4	U	EW_DIO55	
WDRST	28B4	WD_RST	TEMP_START	U	U	U	U	U	U	
MPU PORTS										
P3	SFR B0	DIO_DIR[15:12]				DIO[15:12]				
P2	SFR A0	DIO_DIR[11:8]				DIO[11:8]				
P1	SFR 90	DIO_DIR[7:4]				DIO[7:4]				
P0	SFR 80	DIO_DIR[3:0]				DIO[3:0]				
FLASH										
FLSH_ERASE	SFR 94	FLSH_ERASE[7:0]								
FLSH_CTL	SFR B2	PREBOOT	SECURE	U	U	FLSH_PEND	FLSH_PSTWR	FLSH_MEEN	FLSH_PWE	
FLSH_PGADR	SFR B7	FLSH_PGADR[6:0]							U	
I²C										
EEDATA	SFR 9E	EEDATA[7:0]								
EECTRL	SFR 9F	EECTRL[7:0]								

Table 13. I/O RAM Locations in Alphabetical Order

NAME	LOCATION	RST	WK	DIR	DESCRIPTION		
ADC_E	2704[4]	0	0	R/W	Enables ADC and V _{REF} . When disabled, reduces bias current.		
ADC_DIV	2200[5]	0	0	R/W	ADC_DIV controls the rate of the ADC and FIR clocks. The ADC_DIV setting determines whether MCK is divided by 4 or 8: 0 = MCK/4 1 = MCK/8 The resulting ADC and FIR clock is as shown below.		
					PLL_FAST = 0	PLL_FAST = 1	
					MCK	6.291456MHz	19.660800MHz
					ADC_DIV = 0	1.572864MHz	4.9152MHz
ADC_DIV = 1	0.786432MHz	2.4576MHz					
BCURR	2704[3]	0	0	R/W	Connects a 100µA load to the battery selected by TEMP_BSEL.		
BSENSE[7:0]	2885[7:0]	-	-	R	The result of the battery measurement.		
CE_E	2106[0]	0	0	R/W	CE enable.		
CE_LCTN[5:0]	2109[5:0]	31	31	R/W	CE program location. The starting address for the CE program is 1024 x CE_LCTN.		
CHIP_ID[15:0]	2300[7:0]	0	0	R	These bytes contain the chip identification. CHIP_ID[15:0]: 71M6545T (11B4h) 71M6545HT (11BCh)		
	2301[7:0]	0	0	R			

Table 13. I/O RAM Locations in Alphabetical Order (continued)

NAME	LOCATION	RST	WK	DIR	DESCRIPTION																					
CHOP_E[1:0]	2106[3:2]	0	0	R/W	Chop enable for the reference bandgap circuit. The value of CHOP changes on the rising edge of MUXSYNC according to the value in CHOP_E: 00 = toggle ¹ 01 = positive 10 = reversed 11 = toggle ¹ except at the mux sync edge at the end of an accumulation interval. Note: CHOP_E is the preferred mode for low-noise applications.																					
CHOPR[1:0]	2709[7:6]	00	00	R/W	The CHOP settings for the remote sensor. 00 = Auto chop. Change every MUX frame. 01 = Positive 10 = Negative 11 = Auto chop. Same as 00.																					
DIFF0_E	210C[4]	0	0	R/W	Enables IADC0-IADC1 differential configuration.																					
DIFF2_E	210C[5]	0	0	R/W	Enables IADC2-IADC3 differential configuration.																					
DIFF4_E	210C[6]	0	0	R/W	Enables IADC4-IADC5 differential configuration.																					
DIFF6_E	210C[7]	0	0	R/W	Enables IADC6-IADC7 differential configuration.																					
DIO_R2[2:0] DIO_R3[2:0] DIO_R4[2:0] DIO_R5[2:0] DIO_R6[2:0] DIO_R7[2:0] DIO_R8[2:0] DIO_R9[2:0] DIO_R10[2:0] DIO_R11[2:0] DIO_RPB[2:0]	2455[2:0] 2455[6:4] 2454[2:0] 2454[6:4] 2453[2:0] 2453[6:4] 2452[2:0] 2452[6:4] 2451[2:0] 2451[6:4] 2450[2:0]	0 0 0 0 0 0 0 0 0 0 0	-	R/W	Connects PB and dedicated I/O pins DIO2 through DIO11 to internal resources. If more than one input is connected to the same resource, the MULTIPLE column below specifies how they are combined.																					
					<table border="1"> <thead> <tr> <th>DIO_Rx</th> <th>RESOURCE</th> <th>MULTIPLE</th> </tr> </thead> <tbody> <tr> <td>0</td> <td>NONE</td> <td>-</td> </tr> <tr> <td>1</td> <td>Reserved</td> <td>OR</td> </tr> <tr> <td>2</td> <td>T0 (Timer0 clock or gate)</td> <td>OR</td> </tr> <tr> <td>3</td> <td>T1 (Timer1 clock or gate)</td> <td>OR</td> </tr> <tr> <td>4</td> <td>IO interrupt (int0)</td> <td>OR</td> </tr> <tr> <td>5</td> <td>IO interrupt (int1)</td> <td>OR</td> </tr> </tbody> </table>	DIO_Rx	RESOURCE	MULTIPLE	0	NONE	-	1	Reserved	OR	2	T0 (Timer0 clock or gate)	OR	3	T1 (Timer1 clock or gate)	OR	4	IO interrupt (int0)	OR	5	IO interrupt (int1)	OR
DIO_Rx	RESOURCE	MULTIPLE																								
0	NONE	-																								
1	Reserved	OR																								
2	T0 (Timer0 clock or gate)	OR																								
3	T1 (Timer1 clock or gate)	OR																								
4	IO interrupt (int0)	OR																								
5	IO interrupt (int1)	OR																								
DIO_DIR[15:12] DIO_DIR[11:8] DIO_DIR[7:4] DIO_DIR[3:0]	SFR B0[7:4] SFR A0[7:4] SFR 90[7:4] SFR 80[7:4]	F	F	R/W	Programs the direction of the first 16 DIO pins. 1 indicates output. Ignored if the pin is not configured as I/O. See DIO_PV and DIO_PW for special option for the DIO0 and DIO1 outputs. See DIO_EEX for special option for DIO2 and DIO3. Note that the direction of DIO pins above 15 is set by DIOx[1]. See PORT_E to avoid power-up spikes.																					
DIO[15:12] DIO[11:8] DIO[7:4] DIO[3:0]	SFR B0[3:0] SFR A0[3:0] SFR 90[3:0] SFR 80[3:0]	F	F	R/W	The value on the first 16 DIO pins. When written, changes data on pins configured as outputs. Note that the data for DIO pins above 15 is set by DIOx[0].																					
DIO_EEX[1:0]	2456[7:6]	0	-	R/W	When set, converts pins DIO3/DIO2 to interface with external EEPROM. DIO2 becomes SDCK and DIO3 becomes bidirectional SDATA.																					
					<table border="1"> <thead> <tr> <th>DIO_EEX[1:0]</th> <th>FUNCTION</th> </tr> </thead> <tbody> <tr> <td>00</td> <td>Disable EEPROM interface</td> </tr> <tr> <td>01</td> <td>2-Wire EEPROM interface</td> </tr> <tr> <td>10</td> <td>3-Wire EEPROM interface</td> </tr> <tr> <td>11</td> <td>3-Wire EEPROM interface with separate DO (DIO3) and DI (DIO8) pins.</td> </tr> </tbody> </table>	DIO_EEX[1:0]	FUNCTION	00	Disable EEPROM interface	01	2-Wire EEPROM interface	10	3-Wire EEPROM interface	11	3-Wire EEPROM interface with separate DO (DIO3) and DI (DIO8) pins.											
DIO_EEX[1:0]	FUNCTION																									
00	Disable EEPROM interface																									
01	2-Wire EEPROM interface																									
10	3-Wire EEPROM interface																									
11	3-Wire EEPROM interface with separate DO (DIO3) and DI (DIO8) pins.																									
DIO_PV	2457[6]	0	-	R/W	Causes VARPULSE to be output on pin DIO1.																					
DIO_PW	2457[7]	0	-	R/W	Causes WPULSE to be output on pin DIO0.																					
DIO_PX	2458[7]	0	-	R/W	Causes XPULSE to be output on pin DIO6.																					
DIO_PY	2458[6]	0	-	R/W	Causes YPULSE to be output on pin DIO7.																					
EEDATA[7:0]	SFR 9E	0	0	R/W	Serial EEPROM interface data.																					

Table 13. I/O RAM Locations in Alphabetical Order (continued)

NAME	LOCATION	RST	WK	DIR	DESCRIPTION					
EECTRL[7:0]	SFR 9F	0	0	R/W	Serial EEPROM interface control.					
					STATUS BIT	NAME	READ/ WRITE	RESET STATE	POLARITY	DESCRIPTION
					7	ERROR	R	0	Positive	1 when an illegal command is received.
					6	BUSY	R	0	Positive	1 when serial data bus is busy.
5	RX_ACK	R	1	Positive	1 indicates that the EEPROM sent an ACK bit.					
EQU[2:0]	2106[7:5]	0	0	R/W	Specifies the power equation.					
					EQU[2:0]	DESCRIPTION	ELEMENT 0	ELEMENT 1	ELEMENT 2	RECOMMENDED MUX SEQUENCE
					3	2 element 4W 3 ϕ Delta	VA(IA-IB)/2	0	VC x IC	IA VA IB VB IC VC
					4	2 element 4W 3 ϕ Wye	VA(IA-IB)/2	VB(IC-IB)/2	0	IA VA IB VB IC VC
					5	2 element 4W 3 ϕ Wye	VA x IA	VB x IB	VC x IC	IA VA IB VB IC VC
Note: The available CE codes implement only equation 5. Contact your Maxim representative to obtain CE codes for equation 3 or 4.										
EX_XFER EX_RTC1S EX_RTC1M EX_TCTEMP EX_RTCT EX_SPI EX_EEX EX_XPULSE EX_YPULSE EX_WPULSE EX_VPULSE	2700[0] 2700[1] 2700[2] 2700[3] 2700[4] 2701[7] 2700[7] 2700[6] 2700[5] 2701[6] 2701[5]	0	0	R/W	Interrupt enable bits. These bits enable the XFER_BUSY, the RTC_1SEC, etc. The bits are set by hardware and cannot be set by writing a 1. The bits are reset by writing 0. Note that if one of these interrupts is to be enabled, its corresponding 8051 EX enable bit must also be set.					
EW_DIO4	28B3[2]	0	-	R/W	Connects DIO4 to the WAKE logic and permits DIO4 rising to wake the part. This bit has no effect unless DIO4 is configured as a digital input.					
EW_DIO55	28B3[0]	0	-	R/W	Connects DIO55 to the WAKE logic and permits DIO55 rising to wake the part. This bit has no effect unless DIO55 is configured as a digital input.					
EW_PB	28B3[3]	0	-	R/W	Connects PB to the WAKE logic and permits PB rising to wake the part. PB is always configured as an input.					
EW_RX	28B3[4]	0	-	R/W	Connects RX to the WAKE logic and permits RX rising to wake the part. See the WAKE description on page 84 for de-bounce issues.					
EW_TEMP	28B3[5]	0	-	R/W	Connects the temperature range check hardware to the WAKE logic and permits the range check hardware to wake the part.					

Table 13. I/O RAM Locations in Alphabetical Order (continued)

NAME	LOCATION	RST	WK	DIR	DESCRIPTION	
FIR_LEN[1:0]	210C[2:1]	0	0	R/W	Determines the number of ADC cycles in the ADC decimation FIR filter. PLL_FAST = 1:	
					FIR_LEN[1:0]	ADC CYCLES
					00	141
					01	288
					10	384
					PLL_FAST = 0:	
					FIR_LEN[1:0]	ADC CYCLES
					00	135
					01	276
					10	Not Allowed
					The ADC LSB size and full-scale values depend on the FIR_LEN[1:0] setting.	
FLSH_ERASE[7:0]	SFR 94[7:0]	0	0	W	Flash Erase Initiate FLSH_ERASE is used to initiate either the Flash Mass Erase cycle or the Flash Page Erase cycle. Specific patterns are expected for FLSH_ERASE in order to initiate the appropriate Erase cycle. (default = 0x00). 0x55 = Initiate Flash Page Erase cycle. Must be preceded by a write to FLSH_PGADR[6:0] (SFR 0xB7[7:1]). 0xAA = Initiate Flash Mass Erase cycle. Must be preceded by a write to FLSH_MEEN and the ICE port must be enabled. Any other pattern written to FLSH_ERASE has no effect.	
FLSH_MEEN	SFR B2[1]	0	0	W	Mass Erase Enable 0 = Mass Erase disabled (default). 1 = Mass Erase enabled. Must be re-written for each new Mass Erase cycle.	
FLSH_PEND	SFR B2[3]	0	0	R	Indicates that a timed flash write is pending. If another flash write is attempted, it is ignored.	
FLSH_PGADR[6:0]	SFR B7[7:1]	0	0	W	Flash Page Erase Address Flash Page Address (page 0 thru 63) that is erased during the Page Erase cycle. (default = 0x00). Must be re-written for each new Page Erase cycle.	
FLSH_PSTWR	SFR B2[2]	0	0	R/W	Enables timed flash writes. When 1, and if CE_E = 1, flash write requests are stored in a one-element deep FIFO and are executed when CE_BUSY falls. FLSH_PEND can be read to determine the status of the FIFO. If FLSH_PSTWR = 0 or if CE_E = 0, flash writes are immediate.	
FLSH_PWE	SFR B2[0]	0	0	R/W	Program Write Enable 0 = MOVX commands refer to External RAM Space, normal operation (default). 1 = MOVX @DPTR,A moves A to External Program Space (Flash) @ DPTR. This bit is automatically reset after each byte written to flash. Writes to this bit are inhibited when interrupts are enabled.	
FLSH_RDE	2702[2]	-	-	R	Indicates that the flash may be read by ICE or SPI slave. FLSH_RDE = (!SECURE)	
FLSH_UNLOCK [3:0]	2702[7:4]	0	0	R/W	Must be a '2' to enable any flash modification. See the description of Flash security for more details.	
FLSH_WRE	2702[1]	-	-	R	Indicates that the flash may be written through ICE or SPI slave ports.	
IE_XFER IE_RTC1S IE_RTC1M IE_TCTEMP IE_RTCT IE_SPI IE_EEX IE_XPULSE IE_YPULSE IE_WPULSE IE_VPULSE	SFR E8[0] SFR E8[1] SFR E8[2] SFR E8[3] SFR E8[4] SFR F8[7] SFR E8[7] SFR E8[6] SFR E8[5] SFR F8[4] SFR F8[3]	0	0	R/W	Interrupt flags for external interrupts 2, 5, and 6. These flags monitor the source of the int2, int5, and int6 interrupts (external interrupts to the MPU core). These flags are set by hardware and must be cleared by the software interrupt handler. The IEX2 (SFR 0xC0[1]) and IEX6 (SFR 0xC0[5]) interrupt flags are automatically cleared by the MPU core when it vectors to the interrupt handler. IEX2 and IEX6 must be cleared by writing zero to their corresponding bit positions in SFR 0xC0, while writing ones to the other bit positions that are not being cleared.	

Table 13. I/O RAM Locations in Alphabetical Order (continued)

NAME	LOCATION	RST	WK	DIR	DESCRIPTION
INTBITS	2707[6:0]	–	–	R	Interrupt inputs. The MPU may read these bits to see the input to external interrupts INT0, INT1, up to INT6. These bits do not have any memory and are primarily intended for debug use.
MPU_DIV[2:0]	2200[2:0]	0	0	R/W	MPU clock rate is: $MPU\ Rate = MCK\ Rate \times 2^{-(2+MPU_DIV[2:0])}$. The maximum value for MPU_DIV[2:0] is 4. Based on the default values of the PLL_FAST bit and MPU_DIV[2:0], the power up MPU rate is 6.29MHz/4 = 1.5725MHz. The minimum MPU clock rate is 38.4kHz when PLL_FAST = 1.
MUX2_SEL[3:0]	2104[3:0]	0	0	R/W	Selects which ADC input is to be converted during time slot 2.
MUX3_SEL[3:0]	2104[7:4]	0	0	R/W	Selects which ADC input is to be converted during time slot 3.
MUX4_SEL[3:0]	2103[3:0]	0	0	R/W	Selects which ADC input is to be converted during time slot 4.
MUX5_SEL[3:0]	2103[7:4]	0	0	R/W	Selects which ADC input is to be converted during time slot 5.
MUX6_SEL[3:0]	2102[3:0]	0	0	R/W	Selects which ADC input is to be converted during time slot 6.
MUX7_SEL[3:0]	2102[7:4]	0	0	R/W	Selects which ADC input is to be converted during time slot 7.
MUX8_SEL[3:0]	2101[3:0]	0	0	R/W	Selects which ADC input is to be converted during time slot 8.
MUX9_SEL[3:0]	2101[7:4]	0	0	R/W	Selects which ADC input is to be converted during time slot 9.
MUX10_SEL[3:0]	2100[3:0]	0	0	R/W	Selects which ADC input is to be converted during time slot 10.
MUX_DIV[3:0]	2100[7:4]	0	0	R/W	MUX_DIV[3:0] is the number of ADC time slots in each MUX frame. The maximum number of time slots is 11.
PB_STATE	SFR F8[0]	0	0	R	The de-bounced state of the PB pin.
PERR_RD PERR_WR	SFR FC[6] SFR FC[5]	0	0	R/W	The IC sets these bits to indicate that a parity error on the remote sensor has been detected. Once set, the bits are remembered until they are cleared by the MPU.
PLL_OK	SFR F9[4]	0	0	R	Indicates that the clock generation PLL is settled.
PLL_FAST	2200[4]	0	0	R/W	Controls the speed of the PLL and MCK. 1 = 19.66 MHz (XTAL x 600) 0 = 6.29MHz (XTAL x 192)
PLS_MAXWIDTH[7:0]	210A[7:0]	FF	FF	R/W	PLS_MAXWIDTH[7:0] determines the maximum width of the pulse (low-going pulse if PLS_INV = 0 or high-going pulse if PLS_INV = 1). The maximum pulse width is $(2 \times PLS_MAXWIDTH[7:0] + 1) \times T1$. Where T1 is PLS_INTERVAL[7:0] in units of CK_FIR clock cycles. If PLS_INTERVAL[7:0] = 0 or PLS_MAXWIDTH[7:0] = 255, no pulse width checking is performed and the output pulses have 50% duty cycle.
PLS_INTERVAL[7:0]	210B[7:0]	0	0	R/W	PLS_INTERVAL[7:0] determines the interval time between pulses. The time between output pulses is PLS_INTERVAL[7:0] x 4 in units of CK_FIR clock cycles. If PLS_INTERVAL[7:0] = 0, the FIFO is not used and pulses are output as soon as the CE issues them. PLS_INTERVAL[7:0] is calculated as follows: $PLS_INTERVAL[7:0] = \text{Floor}(\text{Mux frame duration in CK_FIR cycles} / \text{CE pulse updates per Mux frame} / 4)$ For example, since the 71M654xT CE code is written to generate 6 pulses in one integration interval, when the FIFO is enabled (i.e., PLS_INTERVAL[7:0] ≠ 0) and that the frame duration is 1950 CK_FIR clock cycles, PLS_INTERVAL[7:0] should be written with Floor(1950/6/4) = 81 so that the five pulses are evenly spaced in time over the integration interval and the last pulse is issued just prior to the end of the interval.
PLS_INV	210C[0]	0	0	R/W	Inverts the polarity of WPULSE, VARPULSE, XPULSE and YPULSE. Normally, these pulses are active low. When inverted, they become active high.
PORT_E	270C[5]	0	0	R/W	Enables outputs from the pins DIO0–DIO14. PORT_E = 0 after reset and power-up blocks the momentary output pulse that would occur on DIO0 to DIO14.
PQ[20:0]	2886[4:0] 2887[7:0] 2888[7:0]	0	0	R	Temperature compensation value computed by the quadratic compensation formula.

Table 13. I/O RAM Locations in Alphabetical Order (continued)

NAME	LOCATION	RST	WK	DIR	DESCRIPTION		
PQMASK	2511[2:0]	0	0	R/W	Sets the length of the PQ mask. The mask is ANDed with the last four bits of PQ according to the table below. PQMASK also determines the length of PULSE_AUTO in TMUX.		
					PQMASK	MASK	PULSE_AUTO WIDTH
					000	0000	1s
					001	1000	2s
					010	1100	4s
					011	1110	8s
					100	1111	16s
PRE_E	2704[5]	0	0	R/W	Enables the 8x preamplifier.		
PREBOOT	SFRB2[7]	–	–	R	Indicates that preboot sequence is active.		
RCMD[4:0]	SFR FC[4:0]	0	0	R/W	When the MPU writes a non-zero value to RCMD[4:0], the IC issues a command to the appropriate remote sensor. When the command is complete, the IC clears RCMD[4:0].		
RESET	2200[3]	0	0	W	When set, writes a one to WF_RSTBIT and then causes a reset.		
RFLY_DIS	210C[3]	0	0	R/W	Controls how the IC drives the power pulse for the 71M6x03. When set, the power pulse is driven high and low. When cleared, it is driven high followed by an open circuit fly-back interval.		
RMT2_E	2709[3]	0	0	R/W	Enables the remote interface.		
RMT4_E	2709[4]	0	0	R/W	Enables the remote interface.		
RMT6_E	2709[5]	0	0	R/W	Enables the remote interface.		
RMT_RD[15:8] RMT_RD[7:0]	2602[7:0] 2603[7:0]	0	0	R	Response from remote read request.		
RTC_FAIL	2890[4]	0	0	R/W	Indicates that a count error has occurred in the RTC and that the time is not trustworthy. This bit can be cleared by writing a 0.		
RTC_RD	2890[6]	0	0	R/W	Freezes the RTC shadow register so it is suitable for MPU reads. When RTC_RD is read, it returns the status of the shadow register: 0 = up to date, 1 = frozen.		
RTC_SBSC[7:0]	2892[7:0]	–	–	R	Time remaining until the next 1 second boundary. LSB = 1/256 second.		
RTC_TMIN[5:0]	289E[5:0]	0	–	R/W	The target minutes register. See RTC_THR below.		
RTC_THR[4:0]	289F[4:0]	0	–	R/W	The target hours register. The RTC_T interrupt occurs when RTC_MIN becomes equal to RTC_TMIN and RTC_HR becomes equal to RTC_THR.		
RTC_WR	2890[7]	0	0	R/W	Freezes the RTC shadow register so it is suitable for MPU writes. When RTC_WR is cleared, the contents of the shadow register are written to the RTC counter on the next RTC clock (~500 Hz). When RTC_WR is read, it returns 1 as long as RTC_WR is set. It continues to return one until the RTC counter actually updates.		
RTC_SEC[5:0] RTC_MIN[5:0] RTC_HR[4:0] RTC_DAY[2:0] RTC_DATE[4:0] RTC_MO[3:0] RTC_YR[7:0]	2893[5:0] 2894[5:0] 2895[4:0] 2896[2:0] 2897[4:0] 2898[3:0] 2899[7:0]	– – – – – – –	– – – – – – –	R/W	The RTC interface registers. These are the year, month, day, hour, minute and second parameters for the RTC. The RTC is set by writing to these registers. Year 00 and all others divisible by 4 are defined as a leap year. SEC 00 to 59 MIN 00 to 59 HR 00 to 23 (00 = Midnight) DAY 01 to 07 (01 = Sunday) DATE 01 to 31 MO 01 to 12 YR 00 to 99 Each write operation to one of these registers must be preceded by a write to 0x20A0.		
RTM_E	2106[1]	0	0	R/W	Real Time Monitor enable. When 0, the RTM output is low.		
RTM0[9:8] RTM0[7:0] RTM1[7:0] RTM2[7:0] RTM3[7:0]	210D[1:0] 210E[7:0] 210F[7:0] 2110[7:0] 2111[7:0]	0 0 0 0 0	0 0 0 0 0	R/W	Four RTM probes. Before each CE code pass, the values of these registers are serially output on the RTM pin. The RTM registers are ignored when RTM_E = 0. Note that RTM0 is 10 bits wide. The others assume the upper two bits are 00.		

Table 13. I/O RAM Locations in Alphabetical Order (continued)

NAME	LOCATION	RST	WK	DIR	DESCRIPTION
SBASE:[10:0]	2519[2:0] 251A[7:0]	0	0	R/W	Base temperature for limit checking
SECURE	SFR B2[6]	0	0	R/W	Inhibits erasure of page 0 and flash addresses above the beginning of CE code as defined by CE_LCTN[5:0]. Also inhibits the read of flash via the SPI and ICE port.
SFILT	251D[3:0]	0	0	R/W	Filter variable for wake on temperature extremes.
SLEEP	28B2[7]	0	0	W	Puts the part to SLP mode. Ignored if system power is present. The part wakes when the Wake timer expires, when push button is pushed, or when system power returns.
SLOT_EXT[3:0]	2112[3:0]	0	0	R/S	If non-zero, will extend the duration of time slot zero by up to 15 extra crystal cycles. The ADC result for time slot zero will be left-shifted nine bits if SLOT_EXT=0 and four bits if SLOT_EXT≠0.
SMAX[6:0]	251B[6:0]	0	0	R/W	Maximum temperature for limit checking
SMIN[6:0]	251C[6:0]	0	0	R/W	Minimum temperature for limit checking
SPI_CMD[7:0]	SFR FD[7:0]	–	–	R	SPI command register for the 8-bit command from the bus master.
SPI_E	270C[4]	1	1	R/W	SPI port enable.
SPI_SAFE	270C[3]	0	0	R/W	Limits SPI writes to SPI_CMD and a 16-byte region in DRAM. No other writes are permitted.
SPI_STAT[7:0]	2708[7:0]	0	0	R	SPI_STAT contains the status results from the previous SPI transaction. Bit 7: Ready error: The 71M654xT was not ready to read or write as directed by the previous command. Bit 6: Read data parity: This bit is the parity of all bytes read from the 71M654xT in the previous command. Does not include the SPI_STAT byte. Bit 5: Write data parity: This bit is the overall parity of the bytes written to the 71M654xT in the previous command. It includes CMD and ADDR bytes. Bit 4-2: Bottom 3 bits of the byte count. Does not include ADDR and CMD bytes. One, two, and three byte instructions return 111. Bit 1: SPI FLASH mode: This bit is zero when the TEST pin is zero. Bit 0: SPI FLASH mode ready: Used in SPI FLASH mode. Indicates that the flash is ready to receive another write instruction.
STEMP[15:0]	2881[7:0] 2882[7:0]	–	–	R	The result of the temperature measurement.
SUM_SAMPS[12:8] SUM_SAMPS[7:0]	2107[4:0] 2108[7:0]	0	0	R/W	The number of multiplexer cycles per XFER_BUSY interrupt. Maximum value is 8191 cycles.
TC_A[9:0]	2508[1:0] 2509[7:0]	0	0	R/W	Temperature compensation factor for quadratic compensation.
TC_B[11:0]	250A[3:0] 205B[7:0]	0	0	R/W	Temperature compensation factor for quadratic compensation.
TC_C[11:0]	289C[3:0] 289D[7:0]	0	0	R/W	Temperature compensation factor for quadratic compensation.
TEMP_22[12:8] TEMP_22[7:0]	230A[4:0] 230B[7:0]	0	–	R	Storage location for STEMP at 22NC. STEMP is an 11-bit word.
TEMP_BAT	28A0[4]	0	–	R/W	Causes V_{BAT} to be measured whenever a temperature measurement is performed.
TEMP_BSEL	28A0[7]	0	–	R/W	Selects which battery is monitored by the temperature sensor: 1 = V_{BAT} , 0 = V_{BAT_RTC}
TBYTE_BUSY	28A0[3]	0	0	R	Indicates that hardware is still writing the 0x28A0 byte. Additional writes to this byte will be locked out while it is one. Write duration could be as long as 6ms.

Table 13. I/O RAM Locations in Alphabetical Order (continued)

NAME	LOCATION	RST	WK	DIR	DESCRIPTION	
TEMP_PER[2:0]	28A0[2:0]	0	-	R/W	Sets the period between temperature measurements. Automatic measurements can be enabled in any mode (MSN, BRN, or SLP). TEMP_PER = 0 disables automatic temperature updates, in which case TEMP_START may be used by the MPU to initiate a one-shot temperature measurement.	
					TEMP_PER	TIME (s)
					0	No temperature updates
					1-6	$2^{(3+TEMP_PER)}$
7	Continuous updates					
In automatic mode, TEMP_START is the indicator of the temperature sensor status: TEMP_START = 1 (temperature sensor is busy, cannot measure temperature) TEMP_START = 0 (temperature sensor is idle, can measure temperature)						
TEMP_PWR	28A0[6]	0	-	R/W	Selects the power source for the temp sensor: 1 = V_{V3P3D} , 0 = V_{BAT_RTC} . This bit is ignored in SLP mode, where the temp sensor is always powered by V_{BAT_RTC} .	
TEMP_START	28B4[6]	0	0	R/W	When TEMP_PER = 0 automatic temperature measurements are disabled, and TEMP_START may be set by the MPU to initiate a one-shot temperature measurement. TEMP_START is ignored in SLP mode. Hardware clears TEMP_START when the temperature measurement is complete. In automatic mode, TEMP_START is the indicator of the temperature sensor status: TEMP_START = 1 (temperature sensor is busy, cannot measure temperature) TEMP_START = 0 (temperature sensor is idle, can measure temperature)	
TMUX[5:0]	2502[5:0]	-	-	R/W	Selects one of 32 signals for TMUXOUT.	
TMUX2[4:0]	2503[4:0]	-	-	R/W	Selects one of 32 signals for TMUX2OUT.	
TMUXRA[2:0]	270A[2:0]	000	000	R/W	The TMUX setting for the remote isolated sensor (71M6x03).	
VREF_CAL	2704[7]	0	0	R/W	Brings the ADC reference voltage out to the V_{REF} pin. This feature is disabled when VREF_DIS=1.	
VREF_DIS	2704[6]	0	1	R/W	Disables the internal ADC voltage reference.	
VSTAT[2:0]	SFR F9[2:0]	-	-	R	This word describes the source of power and the status of V_{DD} .	
					000	System Power OK. $V_{V3P3A} > 3.0\text{v}$. Analog modules are functional and accurate. [V3AOK,V3OK] = 11
					001	System Power Low. $2.8\text{v} < V_{V3P3A} < 3.0\text{v}$. Analog modules not accurate. Switchover to battery power is imminent. [V3AOK,V3OK] = 01
					010	Battery power and V_{DD} OK. $V_{DD} > 2.25\text{v}$. Full digital functionality. [V3AOK,V3OK] = 00, [VDDOK,VDDgt2] = 11
					011	Battery power and $V_{DD} > 2.0$. Flash writes are inhibited. If the TRIMVDD[5] fuse is blown, PLL_FAST (I/O RAM 0x2200[4]) is cleared. [V3AOK,V3OK] = 00, [VDDOK,VDDgt2] = 01
101	Battery power and $V_{DD} < 2.0$. When VSTAT=101, processor is nearly out of voltage. Processor failure is imminent. [V3AOK,V3OK] = 00, [VDDOK,VDDgt2] = 00					
WAKE_ARM	28B2[5]	0	-	R/W	Arms the WAKE timer and loads it with WAKE_TMR[7:0]. When SLEEP or LCD_ONLY is asserted by the MPU, the WAKE timer becomes active.	
WAKE_TMR[7:0]	2880[7:0]	0	-	R/W	Timer duration is WAKE_TMR+1 seconds.	
WD_RST	28B4[7]	0	0	W	Reset the WD timer. The WD is reset when a 1 is written to this bit. Writing a one clears and restarts the watch dog timer.	
WF_DIO4	28B1[2]	0	-	R	DIO4 wake flag bit. If DIO4 is configured to wake the part, this bit is set whenever the de-bounced version of DIO4 rises. It is held in reset if DIO4 is not configured for wakeup.	
WF_DIO55	28B1[0]	0	-	R	DIO55 wake flag bit. If DIO55 is configured to wake the part, this bit is set whenever the de-bounced version of DIO55 rises. It is held in reset if DIO55 is not configured for wakeup.	
WF_TEMP	28B1[6]	0	-	R	Indicates that the temperature range check hardware caused the part to wake up.	

NAME	LOCATION	RST	WK	DIR	DESCRIPTION
WAKE_ARM	28B2[5]	0	–	R/W	Arms the WAKE timer and loads it with WAKE_TMR[7:0]. When SLEEP or LCD_ONLY is asserted by the MPU, the WAKE timer becomes active.
WF_PB	28B1[3]	–	–	R	Indicates that the PB caused the part to wake.
WF_RX	28B1[4]	0	–	R	Indicates that RX caused the part to wake.
WF_CSTART	28B0[7]	0			Indicates that the Reset pin, Reset bit, ERST pin, Watchdog timer, the cold start detector, or bad V _{BAT} caused the part to reset.
WF_RST	28B0[6]	1			
WF_RSTBIT	28B0[5]	0	–	R	
WF_OVF	28B0[4]	0			
WF_ERST	28B0[3]	0			
WF_BADVDD	28B0[2]	0			

CE Interface Description

CE Program

The CE performs the precision computations necessary to accurately measure energy. These computations include offset cancellation, phase compensation, product smoothing, product summation, frequency detection, VAR calculation, sag detection and voltage phase measurement.

The CE program is supplied by Maxim Integrated as a data image that can be merged with the MPU operational code for meter applications. Typically, the CE program provided with the demonstration code covers most applications and does not need to be modified. Other variations of CE code are available. Contact your local Maxim Integrated representative to obtain the appropriate CE code required for a specific application.

CE Data Format

All CE words are 4 bytes. Unless specified otherwise, they are in 32-bit two's complement format

(-1 = 0xFFFFFFFF). Calibration parameters are defined in flash memory (or external EEPROM) and must be copied to CE data memory by the MPU before enabling the CE. Internal variables are used in internal CE calculations. Input variables allow the MPU to control the behavior of the CE code. Output variables are outputs of the CE calculations. The corresponding MPU address for the most significant byte is given by $0x0000 + 4 \times \text{CE_address}$ and by $0x0003 + 4 \times \text{CE_address}$ for the least significant byte.

Constants

- Sampling Frequency: 2520.62Hz.
- F_0 : Frequency of the mains phases (typically 50Hz or 60Hz).
- I_{MAX}: RMS current corresponding to 250mV peak (176.8 mVRMS) at the inputs IA and IB. I_{MAX} needs to be adjusted if the preamplifier is activated for the IAP-IAN inputs. For a 250 $\mu\Omega$ shunt resistor, I_{MAX} becomes 707A (176.8 mVRMS/250FI = 707.2ARMS).

- V_{MAX}: RMS voltage corresponding to 250mV peak at the VA and VB inputs.
- N_{ACC}: Accumulation count for energy measurements is SUM_SAMPS[12:0]. The duration of the accumulation interval for energy measurements is $\text{SUM_SAMPS}[12:0]/F_S$.
- X: Gain constant of the pulse generators. Its value is determined by PULSE_FAST and PULSE_SLOW.
- Voltage LSB (for sag threshold) = $V_{MAX} \times 7.8798 \times 10^{-9}$ V.

The system constants I_{MAX} and V_{MAX} are used by the MPU to convert internal digital quantities (as used by the CE) to external, i.e., metering quantities. Their values are determined by the scaling of the voltage and current sensors used in an actual meter.

Environment

Before starting the CE using the CE_E bit (I/O RAM 0x2106[0]), the MPU has to establish the proper environment for the CE by implementing the following steps:

- Locate the CE code in flash memory using CE_LCTN[5:0].
- Load the CE data into RAM.
- Establish the equation to be applied in EQU[2:0].
- Establish the number of samples per accumulation period in SUM_SAMPS[12:0].
- Establish the number of cycles per ADC multiplexer frame (MUX_DIV[3:0]).
- Apply proper values to MUXn_SEL, as well as proper selections for DIFFn_E and RMT_E in order to configure the analog inputs.
- Initialize any MPU interrupts, such as CE_BUSY, XFER_BUSY, or the power failure detection interrupt.
- V_{MAX} = 600V, I_{MAX} = 707A, and kWh = 1Wh/pulse are assumed as default settings

When different CE codes are used, a different set of environment parameters need to be established. The exact

values for these parameters are listed in the Application Notes and other documentation which accompanies the CE code.

The CE details described in this data sheet should be considered typical and may not, in aggregate, be indicative of any particular CE code. Contact your Maxim Integrated representative for details about available standard CE codes.

CE Calculations

The MPU selects the basic configuration for the CE by setting the EQU variable.

CE Input Data

Data from the AFE is placed into CE memory by hardware at ADC0-ADC10. [Table 15](#) describes the process.

Status and Control

The CESTATUS register (0x80) contains bits that reflect the status of the signals that are applied to the CE. CECONFIG (0x20) contains bits that control basic operation of the compute engine.

The CE code supports registers to establish the sag threshold and gain for each of the input channels. When the input RMS voltage level falls below an established level, a warning is posted to the MPU. This level is called the sag threshold, and it is set in the SAG_THR register.

Gain for each channel is adjusted in the GAIN_ADJ0 (voltage), GAIN_ADJ1 (current channel A) and GAIN_ADJ2 (current channel B).

Transfer Variables

After each pass through CE program code, the CE asserts a XFER_BUSY interrupt. This informs the MPU that new data is available. It is the responsibility of MPU code to retrieve the data from the CE in a timely manner.

Pulse Generation

WRATE (CE RAM 0x21) along with the PULSE_SLOW and PULSE_FAST bits control the number of pulses that

are generated per measured Wh and VARh quantities. The pulse rate is proportional to the WRATE value for a given energy. The meter constant Kh is derived from WRATE as the amount of energy measured for each pulse. That is, if Kh = 1Wh/pulse, a power applied to the meter of 120 V and 30 A results in one pulse per second; if the load is 240 V at 150 A, ten pulses per second are generated.

Normally, the CE takes the values from W0SUM_X and VAR0SUM_X and moves them to APULSEW and APULSER, respectively. Then, pulse generation logic in the CE creates the actual pulses. However, the MPU can take direct control of the pulse generation process by setting EXT_PULSE = 1. In this case, the MPU sets the pulse rate by directly loading APULSEW and APULSER.

Note that since creep management is an MPU function, when the CE manages pulse output (EXT_PULSE = 0) creep management is disabled.

The maximum pulse rate is $3 \times F_S = 7.56\text{kHz}$.

The maximum time jitter is 1/6 of the multiplexer cycle period (nominally 67µs) and is independent of the number of pulses measured. Thus, if the pulse generator is monitored for one second, the peak jitter is 67ppm. After 10 seconds, the peak jitter is 6.7ppm. The average jitter is always zero. If it is attempted to drive either pulse generator faster than its maximum rate, it simply outputs at its maximum rate without exhibiting any rollover characteristics. The actual pulse rate, using WSUM as an example, is:

$$\text{RATE} = \frac{\text{WRATE} \cdot \text{WSUM} \cdot F_S \cdot X}{2^{46}} \text{Hz}$$

where F_S = sampling frequency (2520.6 Hz), X = Pulse speed factor derived from the CE variables PULSE_SLOW and PULSE_FAST.

[Figure 17](#), [Figure 18](#), and [Figure 19](#) show the data flow through the CE in simplified form. Functions not shown include delay compensation, sag detection, scaling, and the processing of meter equations.

CE Flow Diagrams

Table 14. Power Equations

EQU[2:0]	WATT AND VAR FORMULA (WSUM/VARSUM)	W0SUM/ VAR0SUM	W1SUM/ VAR1SUM	W2SUM/ VAR2SUM	I0SQ SUM	I1SQ SUM	I2SQ SUM
3	$VA \times (IA-IB/2) + VC \times IC$ (2 element 4W 3 ϕ >Delta)	$VA \times (IA-IB)/2$	—	$VC \times IC$	IA-IB	IB	IC
4	$VA \times (IA-IB)/2 + VB(IC-IB)/2$ (2 element 4W 3 ϕ >Wye)	$VA \times (IA-IB)/2$	$VB \times (IC-IB)$	—	IA-IB	IC-IB	IC
5	$VA \times IA + VB \times IB + VC \times IC$ (3 element 4W 3 ϕ > Wye)	$VA \times IA$	$VB \times IB$	$VC \times IC$	IA	IB	IC

Table 15. CE Raw Data Access Locations

PIN	MUXn_SEL HANDLE				CE RAM LOCATION			
	DIFF0_E				DIFF0_E			
	0	1			0	1		
IADC0	0	0			0	0		
IADC1	1				1			
	RMT2_E, DIFF2_E				RMT2_E, DIFF2_E			
	0,0	0,1	1,0	1,1	0,0	0,1	1,0	1,1
IADC2	2	2	-	-	2	2	2*	2*
IADC3	3				3			
	RMT4_E, DIFF4_E				RMT4_E, DIFF4_E			
	0,0	0,1	1,0	1,1	0,0	0,1	1,0	1,1
IADC4	4	4	-	-	4	4	4*	4*
IADC5	5				5			
	RMT6_E, DIFF6_E				RMT6_E, DIFF6_E			
	0,0	0,1	1,0	1,1	0,0	0,1	1,0	1,1
IADC6	6	6	-	-	6	6	6*	6*
IADC7	7				7			
	There are no configuration bits for VADC8, 9, 10							
VADC8 (VA)	8				8			
VADC9 (VB)	9				9			
VADC10 (VC)	10				10			

*Remote interface data.

Table 16. CE Status Register

CESTATUS BIT	NAME	DESCRIPTION
31:4	Not used	These unused bits are always zero.
3	F0	F0 is a square wave at the exact fundamental input frequency.
2	SAG_C	Normally zero. Becomes one when VB remains below SAG_THR for SAG_CNT samples. Does not return to zero until VB rises above SAG_THR.
1	SAG_B	Normally zero. Becomes one when VB remains below SAG_THR for SAG_CNT samples. Does not return to zero until VB rises above SAG_THR.
0	SAG_A	Normally zero. Becomes one when VA remains below SAG_THR for SAG_CNT samples. Does not return to zero until VA rises above SAG_THR.

Table 17. CE Configuration Register

CECONFIG BIT	NAME	DEFAULT	DESCRIPTION		
22	EXT_TEMP	0	When 1, the MPU controls temperature compensation through the GAIN_ADJn registers (CE RAM 0x40-0x42), when 0, the CE is in control.		
21	EDGE_INT	1	When 1, XPULSE produces a pulse for each zero-crossing of the mains phase selected by FREQSEL[1:0], which can be used to interrupt the MPU.		
20	SAG_INT	1	When 1, activates YPULSE output when a sag condition is detected.		
19:8	SAG_CNT	252 (0xFC)	The number of consecutive voltage samples below SAG_THR (CE RAM 0x24) before a sag alarm is declared. The default value is equivalent to 100 ms.		
7:6	FREQSEL[1:0]	0	FREQSEL[1:0] selects the phase to be used for the frequency monitor, sag detection, and for the zero crossing counter (MAINEDGE_X).		
			FREQ SEL[1:0]	PHASE SELECTED	
			0	A	
			0	B*	
			1	X	Not allowed
5	EXT_PULSE	1	When zero, causes the pulse generators to respond to internal data (WPULSE = WSUM_X, VPULSE = VARSUM_X). Otherwise, the generators respond to values the MPU places in APULSEW and APULSER.		
4:2	Reserved	0	Reserved.		
1	PULSE_FAST	0	When PULSE_FAST = 1, the pulse generator input is increased 16x. When PULSE_SLOW = 1, the pulse generator input is reduced by a factor of 64. These two parameters control the pulse gain factor X (see table below). Allowed values are either 1 or 0. Default is 0 for both (X = 6).		
0	PULSE_SLOW	0	PULSE_FAST	PULSE_SLOW	X
			0	0	$1.5 \times 2^2 = 6$
			1	0	$1.5 \times 2^6 = 96$
			0	1	$1.5 \times 2^{-4} = 0.09375$
			1	1	Do not use

Table 18. Sag Threshold and Gain Adjustment Registers

CE ADDRESS	NAME	DEFAULT	DESCRIPTION
0x24	SAG_THR	2.39×10^7	The voltage threshold for sag warnings. The default value is equivalent to 113V peak or 80 VRMS if VMAX = 600VRMS. $\text{SAG_THR} = \frac{V_{\text{RMS}} \cdot \sqrt{2}}{V_{\text{MAX}} \cdot 7.8798 \cdot 10^{-9}}$
0x40	GAIN_ADJ0	16384	This register scales the voltage measurement channels VADC8 (VA), VADC9 (VB) AND VADC10 (VC). The default value of 16384 is equivalent to unity gain (1.000).
0x41	GAIN_ADJ1	16384	This register scales the neutral current channel for neutral current. The default value of 16384 is equivalent to unity gain (1.000).
0x42	GAIN_ADJ2	16384	This register scales the IA current channel for Phase A. The default value of 16384 is equivalent to unity gain (1.000).
0x43	GAIN_ADJ3	16384	This register scales the IB current channel for Phase B. The default value of 16384 is equivalent to unity gain (1.000).
0x44	GAIN_ADJ4	16384	This register scales the IC current channel for Phase C. The default value of 16384 is equivalent to unity gain (1.000).

Table 19. CE Transfer Registers

CE ADDRESS	NAME	DESCRIPTION
0x84†	WSUM_X	The signed sum: W0SUM_X+W1SUM_X. Not used for EQU[2:0] = 0 and EQU[2:0] = 1.
0x85	W0SUM_X	The sum of Wh samples from each wattmeter element.
0x86	W1SUM_X	LSB = $9.4045 \times 10^{-13} \times V_{\text{MAX}} \times \text{IMAX Wh}$ (local)
0x87	W2SUM_X	LSB = $1.55124 \times 10^{-12} \times V_{\text{MAX}} \times \text{IMAX Wh}$ (remote)
0x88†	VARSUM_X	The signed sum: VAR0SUM_X+VAR1SUM_X. Not used for EQU[2:0] = 0 and EQU[2:0] = 1.
0x89	VAR0SUM_X	The sum of VARh samples from each wattmeter element.
0x8A	VAR1SUM_X	LSB = $9.4045 \times 10^{-13} \times V_{\text{MAX}} \times \text{IMAX VARh}$ (local)
0x8B	VAR2SUM_X	LSB = $1.55124 \times 10^{-12} \times V_{\text{MAX}} \times \text{IMAX VARh}$ (remote)
0x8C	I0SQSUM_X	The sum of squared current samples from each element. LSB = $9.4045 \times 10^{-13} \times \text{IMAX}^2 \text{ A}^2\text{h}$ (local) LSB = $2.55872 \times 10^{-12} \times \text{IMAX}^2 \text{ A}^2\text{h}$ (remote)
0x8D	I1SQSUM_X	
0x8E	I2SQSUM_X	
0x8F	I3SQSUM_X	
0x90	V0SQSUM_X	The sum of squared voltage samples from each element. LSB = $9.4045 \times 10^{-13} \times V_{\text{MAX}}^2 \text{ V}^2\text{h}$ (local) LSB = $9.40448 \times 10^{-13} \times V_{\text{MAX}}^2 \text{ V}^2\text{h}$ (remote)
0x91	V1SQSUM_X	
0x92	V2SQSUM_X	
0x82	FREQ_X	Fundamental frequency: LSB = $\frac{2520.6\text{Hz}}{2^{32}} \approx 0.509 \cdot 10^{-6} \text{Hz}$ (for Local) LSB = $\frac{2520.6\text{Hz}}{2^{32}} \approx 0.587 \cdot 10^{-6} \text{Hz}$ (for Remote)
0x83	MAINEDGE_X	The number of edge crossings of the selected voltage in the previous accumulation interval. Edge crossings are either direction and are debounced.

Table 20. CE Pulse Generation Parameters

CE ADDRESS	NAME	DEFAULT	DESCRIPTION
0x21	WRATE	547	$K_h = \frac{V_{MAX} \cdot I_{MAX} \cdot K}{WRATE \cdot N_{ACC} \cdot X} \cdot Wh / pulse$ <p>where: K = 66.1782 (Local Sensors) K = 109.1587 (Remote Sensor) N_{ACC} = SUM_SAMPS[12:0] (CE RAM 0x23) X is a factor determined by PULSE_FAST and PULSE_SLOW. See CECONFIG definition for more information The default value yields 1.0 Wh/pulse for V_{MAX} = 600 V and I_{MAX} = 208 A. The maximum value for WRATE is 32,768 (2¹⁵).</p>
0x22	KVAR	6444	Scale factor for VAR measurement.
0x23	SUM_SAMPS	2520	SUM_SAMPS (N _{ACC}).
0x45	APULSEW	0	Wh pulse (WPULSE) generator input to be updated by the MPU when using external pulse generation. The output pulse rate is: $APULSEW \times f_S \times 2^{-32} * WRATE \times X \times 2^{-14}$. This input is buffered and can be updated by the MPU during a conversion interval. The change takes effect at the beginning of the next interval.
0x46	WPULSE_CTR	0	WPULSE counter.
0x47	WPULSE_FRAC	0	Unsigned numerator, containing a fraction of a pulse. The value in this register always counts up towards the next pulse.
0x48	WSUM_ACCUM	0	Roll-over accumulator for WPULSE.
0x49	APULSER	0	VARh (VPULSE) pulse generator input.
0x4A	VPULSE_CTR	0	VPULSE counter.
0x4B	VPULSE_FRAC	0	Unsigned numerator, containing a fraction of a pulse. The value in this register always counts up towards the next pulse.
0x4C	VSUM_ACCUM	0	Roll-over accumulator for VPULSE.

Table 21. Other CE Parameters

CE ADDRESS	NAME	DEFAULT	DESCRIPTION
0x25	QUANT_VA	0	Compensation factors for truncation and noise in voltage, current, real energy and reactive energy for phase A.
0x26	QUANT_IA	0	
0x27	QUANT_A	0	
0x28	QUANT_VARA	0	
0x29 †	QUANT_VB	0	Compensation factors for truncation and noise in voltage, current, real energy and reactive energy for phase B.
0x2A	QUANT_IB	0	
0x2B	QUANT_B	0	
0x2C	QUANT_VARB	0	
0x2D	QUANT_VC	0	Compensation factors for truncation and noise in voltage, current, real energy and reactive energy for phase C.
0x2E	QUANT_IC	0	
0x2F	QUANT_C	0	
0x30	QUANT_VARC	0	
0x38	0x43453431		CE file name identifier in ASCII format (CE41a01f). These values are overwritten as soon as the CE starts
0x39	0x6130316B		
0x3A	0x00000000		
<p>LSB weights for use with Local Sensors:</p> <p>QUANT_Ix_LSB = $5.08656 \cdot 10^{-13} \cdot \text{IMAX}^2$ (Amps²)</p> <p>QUANT_Wx_LSB = $1.04173 \cdot 10^{-9} \cdot \text{VMAX} \cdot \text{IMAX}$ (Watts)</p> <p>QUANT_VARx_LSB = $1.04173 \cdot 10^{-9} \cdot \text{VMAX} \cdot \text{IMAX}$ (Vars)</p> <p>LSB weights for use with the 71M6x03 isolated sensors:</p> <p>QUANT_Ix_LSB = $1.38392 \cdot 10^{-12} \cdot \text{IMAX}^2$ (Amps²)</p> <p>QUANT_Wx_LSB = $1.71829 \cdot 10^{-9} \cdot \text{VMAX} \cdot \text{IMAX}$ (Watts)</p> <p>QUANT_VARx_LSB = $1.71829 \cdot 10^{-9} \cdot \text{VMAX} \cdot \text{IMAX}$ (Vars)</p>			

Table 22. CE Calibration Parameters

CE ADDRESS	NAME	DEFAULT	DESCRIPTION
0x10	CAL_IA	16384	These constants control the gain of their respective channels. The nominal value for each parameter is $2^{14} = 16384$. The gain of each channel is directly proportional to its CAL parameter. Thus, if the gain of a channel is 1% slow, CAL should be increased by 1%. Refer to the <i>71M6x03 Demo Board User's Manual</i> for the equations to calculate these calibration parameters.
0x11	CAL_VA	16384	
0x13	CAL_IB	16384	
0x14	CAL_VB	16384	
0x12	PHADJ_A	0	These constants control the CT phase compensation. Compensation does not occur when PHADJ_X = 0. As PHADJ_X is increased, more compensation (lag) is introduced. The range is P 215 – 1. If it is desired to delay the current by the angle Φ , the equations are: $\text{PHADJ_X} = 2^{20} \frac{0.02229 \cdot \tan(\Phi)}{0.1487 - 0.0131 \cdot \tan(\Phi)} \text{ at 60Hz}$ $\text{PHADJ_X} = 2^{20} \frac{0.0155 \cdot \tan(\Phi)}{0.1241 - 0.009695 \cdot \tan(\Phi)} \text{ at 50Hz}$
0x15	PHADJ_B	0	
0x18	PHADJ_C	0	
0x12	L_COMP2_A	16384	The shunt delay compensation is obtained using the equation provided below: where: f_S = sampling frequency f = mains frequency
0x15	L_COMP2_B	16384	
0x18	L_COMP2_C	16384	

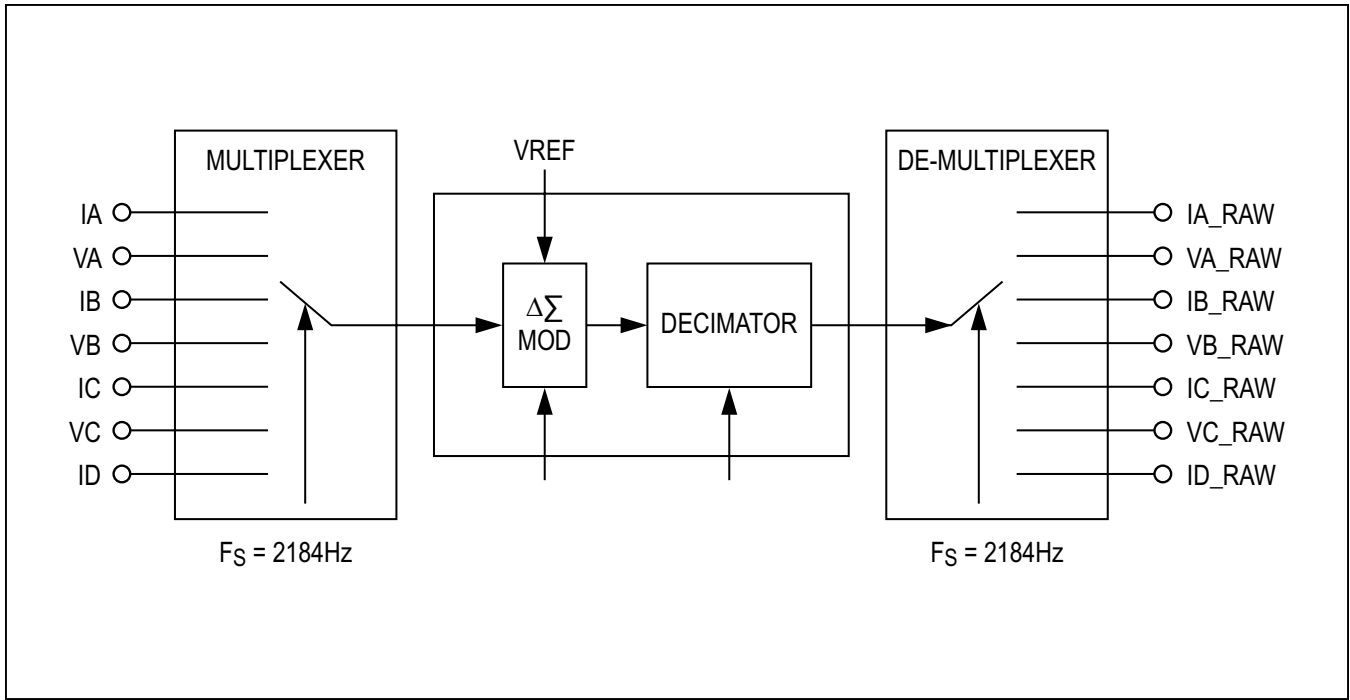

Figure 17. CE Data Flow—Multiplexer and ADC

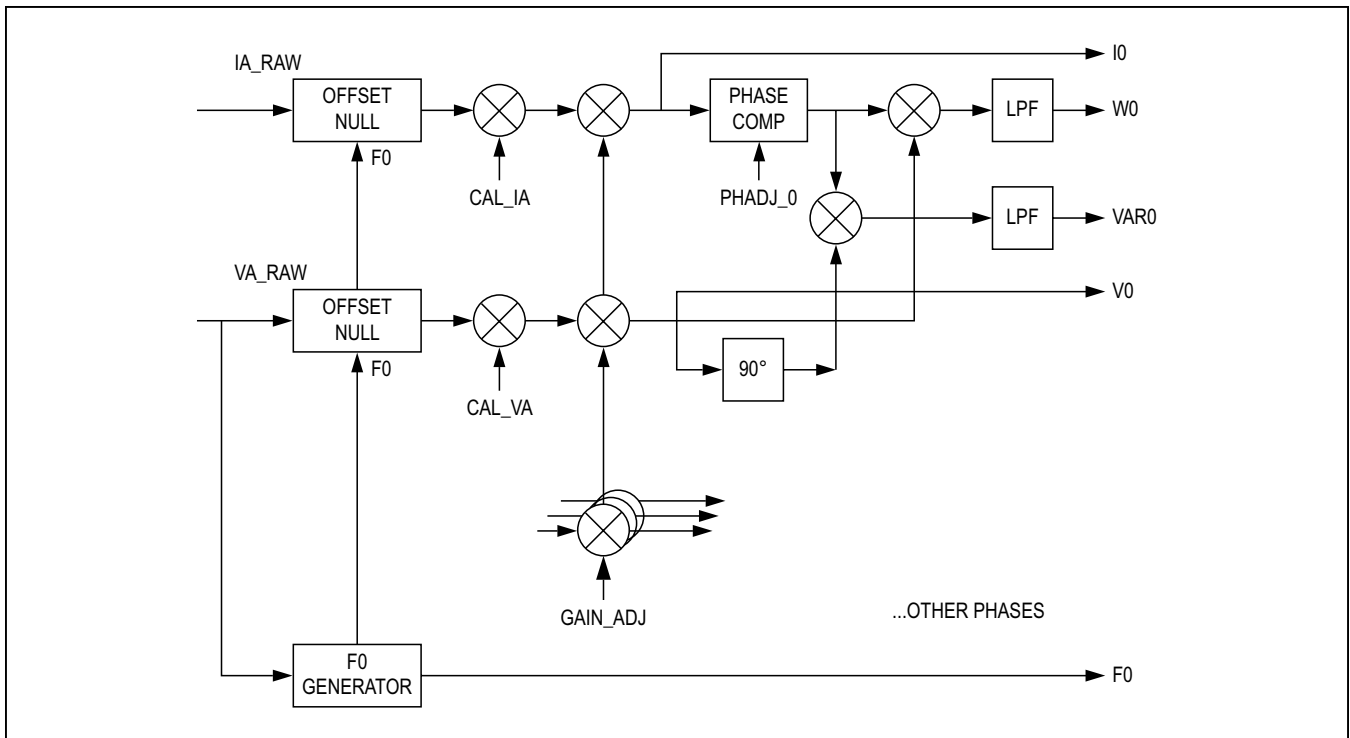

Figure 18. CE Data Flow—Offset, Gain, and Phase Compensation

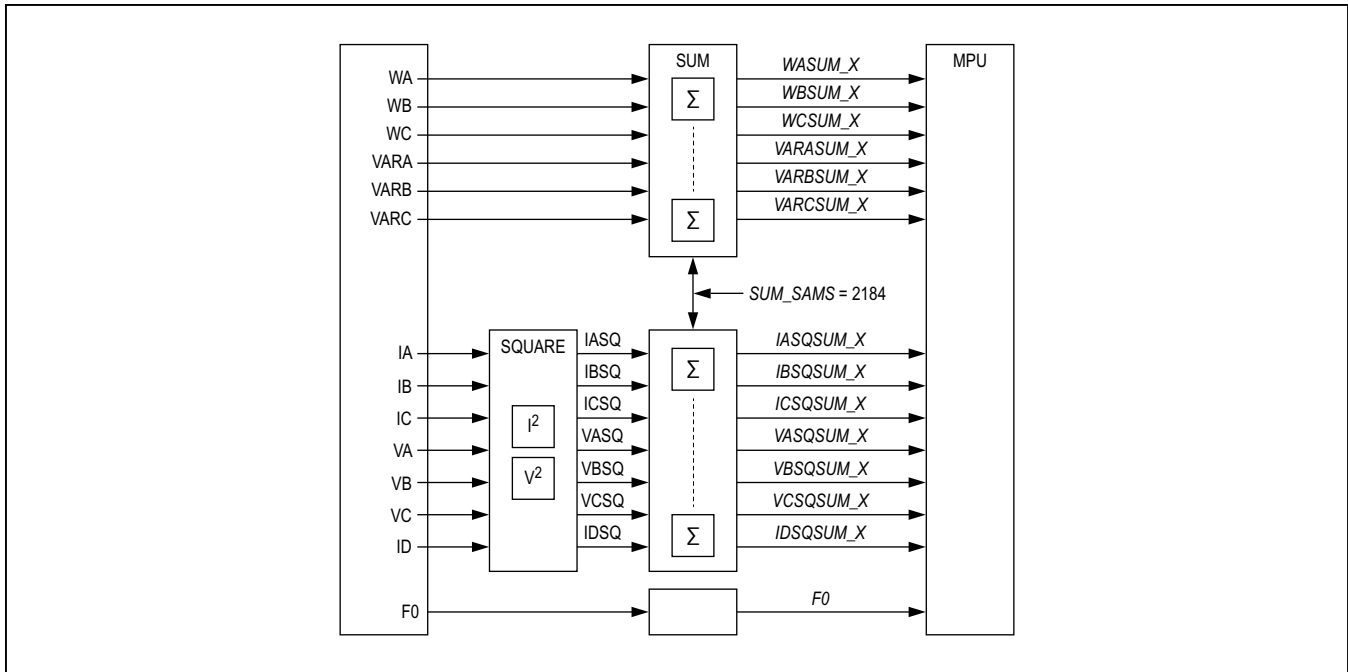

Figure 19. CE Data Flow—Squaring and Summation

Ordering Information

PART	TEMP RANGE	ACCURACY (typ, %)	FLASH (KB)	PIN-PACKAGE
71M6545T-IGT/F	-40°C to +85°C	0.1	64	64 LQFP
71M6545T-IGTR/F	-40°C to +85°C	0.1	64	64 LQFP
71M6545HT-IGT/F	-40°C to +85°C	0.1	64	64 LQFP
71M6545HT-IGTR/F	-40°C to +85°C	0.1	64	64 LQFP

F = Lead(Pb)-free/RoHS-compliant package.

R = Tape and reel.

Package Information

For the latest package outline information and land patterns (footprints), go to www.maximintegrated.com/packages. Note that a "+", "#", or "-" in the package code indicates RoHS status only. Package drawings may show a different suffix character, but the drawing pertains to the package regardless of RoHS status.

PACKAGE TYPE	PACKAGE CODE	OUTLINE NO.	LAND PATTERN NO.
64 LQFP	C64L+7	21-0665	90-0411

Revision History

REVISION NUMBER	REVISION DATE	DESCRIPTION	PAGES CHANGED
0	8/13	Initial release	—
1	10/13	Removed “future product” status on 71M6545HT in the <i>Ordering Information</i> table, updated the V_{REF} Error specification in the <i>Electrical Characteristics</i>	10, 62
2	12/13	Updated the CXL and CXS capacitor values from 10pF and 15pF to 22pF	12, 14
3	3/14	Updated the V_{REF} coefficients in the <i>Electrical Characteristics</i> table; removed Note 2 from the EC notes; changed CXS and CXL notes in the <i>Recommended External Components</i> table	8, 10, 12
4	1/15	Updated the <i>Benefits and Features</i> section	1
5	12/15	Added a new <i>Reading the Info Page</i> section, a new Test Port table, a replacement for Table 13, and removed Table 12; updated Table 11 and Table 19; renumbered tables 10-12 accordingly; corrected land pattern number	35, 47, 52, 54, 55, 58, 64

For pricing, delivery, and ordering information, please contact Maxim Direct at 1-888-629-4642, or visit Maxim’s website at www.maximintegrated.com.

Maxim Integrated cannot assume responsibility for use of any circuitry other than circuitry entirely embodied in a Maxim Integrated product. No circuit patent licenses are implied. Maxim Integrated reserves the right to change the circuitry and specifications without notice at any time. The parametric values (min and max limits) shown in the *Electrical Characteristics* table are guaranteed. Other parametric values quoted in this data sheet are provided for guidance.

Looking for pricing, stock, or lifecycle information?

Click below to explore more details on WIN SOURCE:

 [View 71M6545T-IGT/F on WIN SOURCE](#)

 [Maxim Integrated Information](#)

Optimize Your Supply Chain with WIN SOURCE Solutions

-  Global Sourcing Solution
-  Obsolete Management
-  Cost Control Management
-  Shortage Management
-  Alternative Solution
-  Excess Inventory Management