



**THE DATASHEET OF
A1454KLETR-2N-T**



3 V Hall-Effect Linear Sensor with I²C Output

FEATURES AND BENEFITS

- 1 mm thin 8-pin TSSOP package
- Two factory-programmed sensitivity options:
 - 2 LSB/G (for fields up to ±1000 G)
 - 4 LSB/G (±500 G)
- Temperature-stable sensitivity for NdFeB and ferrite magnets
- I²C interface for easy integration, with support for up to 127 unique addresses
- EEPROM stores factory-programmed settings and up to 26 bits of user information (programmable through the I²C interface)
- Micropower sleep mode through I²C command for minimizing power in battery-operated applications
- Precise recoverability after temperature cycling
- Wide ambient temperature range: -40°C to 125°C
- 12-bit ADC with 10-bit ENOB (Effective Number of Bits)

Package: 8-Pin TSSOP (suffix LE)

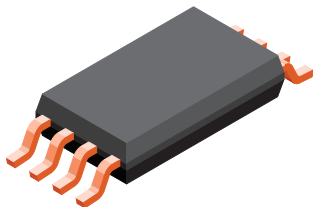

Not to scale

DESCRIPTION

The A1454 linear Hall-effect sensor IC provides a 12-bit digital output word that is proportional to the strength of the magnetic field that is present. Its quiescent output value is at mid-scale, and it comes in two different factory-programmed sensitivity ranges: 2 LSB/G and 4 LSB/G. The sensitivity temperature coefficient is also factory-programmed to support either neodymium or ferrite magnets. The A1454 incorporates an I²C interface for easy integration into a wide variety of applications. The I²C address can either be set by external resistors or programmed via EEPROM to support up to 127 unique I²C addresses, allowing for multiple ICs on the same bus. It also includes 26 bits of user-programmable EEPROM.

The A1454 I²C interface provides a user-controlled sleep input command that puts the device in micropower mode, which reduces the current consumption of the A1454. This low power feature makes the A1454 perfect for portable, battery-operated applications.

The BiCMOS monolithic process allows the integration of both high-precision analog and high-density digital circuitry. The A1454 integrates the Hall element, a 12-bit ADC, gain and offset compensation circuitry, EEPROM memory, and the I²C interface on a single monolithic IC that is packaged in a space-saving surface-mount package.

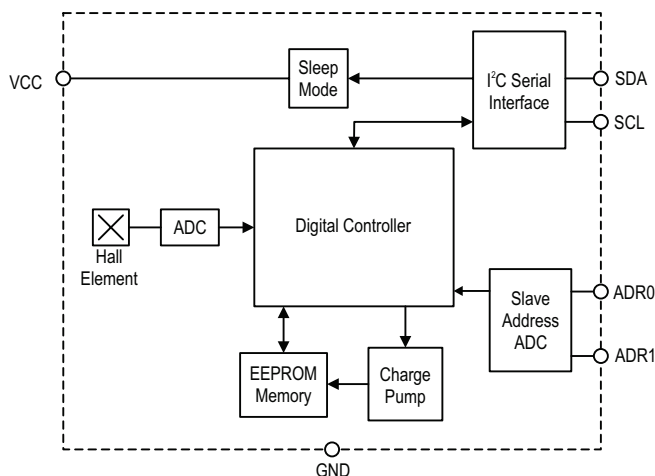

Functional Block Diagram

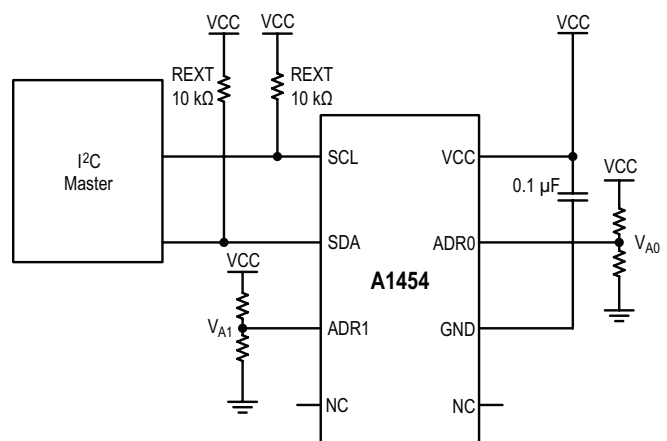

Typical Application Circuit

SPECIFICATIONS

SELECTION GUIDE

Part Number	Sensitivity	Target Magnet	Packing*	Package
A1454KLETR-2F-T	2 LSB/G	Ferrite	4000 pieces per reel	8-Pin TSSOP Package
A1454KLETR-4F-T	4 LSB/G	Ferrite		
A1454KLETR-2N-T	2 LSB/G	Neodymium		
A1454KLETR-4N-T	4 LSB/G	Neodymium		



* Contact Allegro™ for additional packing options.

ABSOLUTE MAXIMUM RATINGS

Characteristic	Symbol	Notes	Rating	Unit
Forward Supply Voltage	V _{CC}		5.0	V
Reverse Supply Voltage	V _{RCC}		-0.1	V
Forward SCL Pin Voltage	V _{I2C(SCL)}		5.5	V
Forward SDA Pin Voltage	V _{I2C(SDA)}		5.5	V
Reverse SCL and SDA Voltage	V _{RI2C}		-0.1	V
Operating Ambient Temperature	T _A	Range K	-40 to 125	°C
Maximum Junction Temperature	T _{J(max)}		165	°C
Storage Temperature	T _{stg}		-65 to 170	°C

THERMAL CHARACTERISTICS: May require derating at maximum conditions; see application information

Characteristic	Symbol	Test Conditions*	Value	Unit
Package Thermal Resistance	R _{θJA}	On single-layer PCB with copper limited to solder pads	137	°C/W

*Additional thermal information available on the Allegro website.

PINOUT DIAGRAM AND TERMINAL LIST TABLE



Package LE, 8-Pin TSSOP Pinout Diagram

Terminal List Table

Number	Name	Function
1	VCC	Device Supply Voltage Pin
2	ADR0	Address Select Pin 0
3	GND	Device Ground Pin
4	NC	No Connection
5	NC	No Connection
6	ADR1	Address Select Pin1
7	SDA	I ² C interface SDA Pin
8	SCL	I ² C interface SCL Pin

OPERATING CHARACTERISTICS: Valid at T_A = 25°C, V_{CC} = 3.0 V, and C_{BYPASS} = 0.1 μF, unless otherwise noted

Characteristics	Symbol	Test Conditions	Min.	Typ.	Max.	Unit
ELECTRICAL CHARACTERISTICS						
Supply Voltage	V _{CC}	Normal Operation	2.65	3.0	3.5	V
		EEPROM programming	2.8	–	3.5	V
Turn On Delay ¹	t _{DON}	After V _{CC(min)} is reached	–	30	–	ms
Supply Current	I _{CC}	V _{CC} = V _{CC(max)} ; Active mode	–	2	5	mA
		V _{CC} = V _{CC(max)} ; Sleep mode	–	0.2	1	μA
		V _{CC} = V _{CC(max)} ; EEPROM programming occurring	–	2	5	mA
Internal Bandwidth ²	BW _I	Small signal –3 dB	–	2	–	kHz
Output Refresh Rate ³	f _{OUT}		–	32	–	kHz
POR V _{CC} Low Time ⁴	t _{POR}	V _{CC} goes below V _{CC(min)}	–	100	–	ms
Number of EEPROM Writes	–	Number of times the EEPROM can be written	–	–	1000	writes
ADDRESS PIN CHARACTERISTICS						
Address Value 0 Reference ²	V _{ADDR0}	ADR0, ADR1 Pins	–	0	0.1	× V _{CC}
Address Value 1 Reference ²	V _{ADDR1}	ADR0, ADR1 Pins	0.23	0.33	0.43	× V _{CC}
Address Value 2 Reference ²	V _{ADDR2}	ADR0, ADR1 Pins	0.57	0.67	0.77	× V _{CC}
Address Value 3 Reference ²	V _{ADDR3}	ADR0, ADR1 Pins	0.90	0.100	–	× V _{CC}
Address Pin Input Resistance	R _{IN}	ADR0, ADR1 Pins	0.8	1	1.2	MΩ

¹ The device will not respond to I²C inputs until after the turn-on delay.

² Determined by design and characterization, not evaluated at final test.

³ The rate at which a new output value is available to be read by the I²C interface.

⁴ If V_{CC} is below V_{CC(min)} for this amount of time, the device will reset when V_{CC} goes above V_{CC(min)}. If the device is in Sleep mode when V_{CC} goes below V_{CC(min)}, this time will be much longer due to the slow discharge of internal capacitors while in Sleep mode.

MAGNETIC CALIBRATION CHARACTERISTICS: Valid at $T_A = 25^\circ\text{C}$ and $C_{\text{BYPASS}} = 0.1 \mu\text{F}$, unless otherwise noted

Characteristics	Symbol	Test Conditions	Min.	Typ.	Max.	Unit ¹
Factory-Programmed Quiescent Voltage Output	QVO		–	±10	–	LSB
Factory-Programmed Sensitivity	Sens	A1454KLETR-4N, FSI = ±500 G	–	4.0	–	LSB/G
		A1454KLETR-4F, FSI = ±500 G	–	4.0	–	LSB/G
		A1454KLETR-2N, FSI = ±1000 G	–	2.0	–	LSB/G
		A1454KLETR-2F, FSI = ±1000 G	–	2.0	–	LSB/G
Sensitivity Temperature Coefficient	TC _{sens}	NdFeB compensated applies to part numbers with suffix 'N' ²	–	0.12	–	%/°C
		Ferrite compensated applies to part numbers with suffix 'F' ³	–	0.21	–	%/°C
Linearity Sensitivity Error ⁴	Lin _{ERR}		–	<±1	–	%
Effective Number of Bits		B = 1000 G	–	~10	–	bits
		B = 500 G	–	~9	–	bits
Sensitivity Error versus Temperature	Sens _{ERR}	T _A = –40°C to 85°C	–	<±3	–	%
		T _A = –40°C to 125°C	–	<±6	–	%

¹ 1 G (gauss) = 0.1 mT (millitesla).

² The slope of the Hall gain function with temperature change is meant to compensate for the variation of a neodymium magnet with temperature.

³ The slope of the Hall gain function with temperature change is meant to compensate for the variation of a ferrite magnet with temperature.

⁴ See Characteristic Definitions section.

I²C INTERFACE CHARACTERISTICS^{1,2}: Valid at T_A = 25°C, V_{CC} = 3.0 V, and R_{EXT} = 10 kΩ, unless otherwise noted

Characteristics	Symbol	Test Conditions	Min.	Typ.	Max.	Unit
Bus Free Time Between Stop and Start	t _{BUF}		1.3	–	–	μs
Hold Time Start Condition	t _{hdSTA}		0.6	–	–	μs
Setup Time for Repeated Start Condition	t _{suSTA}		0.6	–	–	μs
SCL Low Time	t _{LOW}		1.3	–	–	μs
SCL High Time	t _{HIGH}		0.6	–	–	μs
Data Setup Time	t _{suDAT}		100	–	–	ns
Data Hold Time	t _{hdDAT}		0	–	900	ns
Setup Time for Stop Condition	t _{suSTO}		0.6	–	–	μs
Logic Input Low Level (SDA, SCL pins)	V _{IL}		–	–	30	%V _{CC}
Logic Input High Level (SDA, SCL pins)	V _{IH}		70	–	–	%V _{CC}
Logic Input Current	I _{IN}	V _{IN} = 0 V to V _{CC}	–1	0	1	μA
Output Voltage (SDA pin)	V _{OL}	I _{LOAD} = 1.5 mA	–	–	0.36	V
Clock Frequency (SCL pin)	f _{CLK}		–	–	400	kHz
Output Fall Time (SDA pin)	t _f	R _{EXT} = 10 kΩ, C _B = 100 pF	–	–	250	ns
I ² C Pull-Up Resistance	R _{EXT}		2.4	10	–	kΩ
Total Capacitive Load for Each of SDA and SCL Buses	C _B		–	–	100	pF

¹ I²C Interface Characteristics are ensured by design and not factory tested.

² Contact Allegro for 1.8 V I²C bus support.

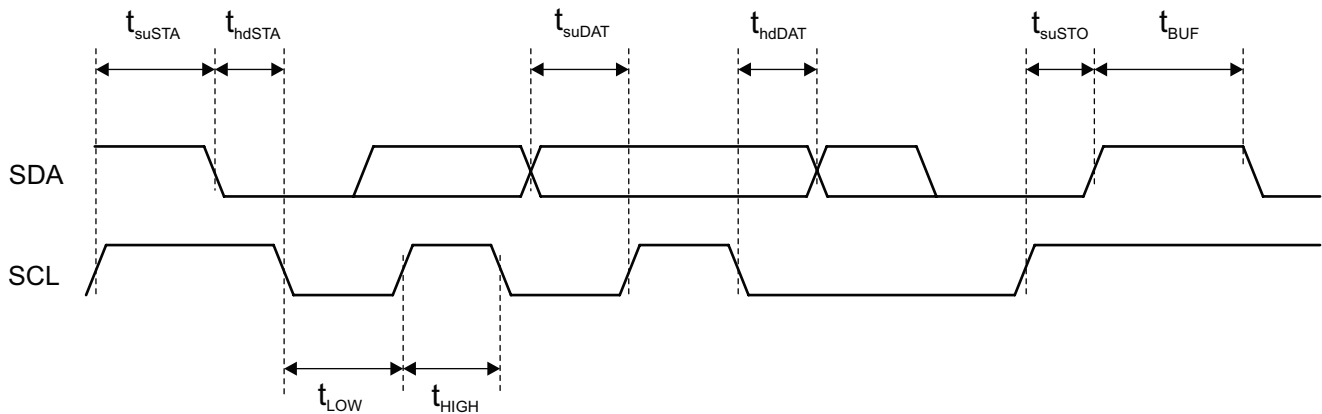

Figure 1: I²C Interface Timing Diagram

PRIMARY REGISTERS

Customer-Accessible Registers

Table 1 shows registers that are customer accessible and can be read/written using the I²C protocol.

Table 1: Customer-Accessible Registers

Address	Name	Bit Field																											
		25	24	23	22	21	20	19	18	17	16	15	14	13	12	11	10	9	8	7	6	5	4	3	2	1	0		
0x1D	Temp Out [11:0]																												Temperature Sensor Output
0x1F	Output [11:0]																												Sensor Output
0x20	Sleep [0]																											Sleep	

Sensor Output

The A1454 provides a 12-bit digital output that is proportional to the magnetic field applied normally to the Hall element.

Table 2: Output [11:0], Address 0x1F, Bit Definition Table

Bits	Address	Name	Value	Description	R/W	Default
11:0	0x1F	Output	0/1 (for each bit)	12-bit signed signal proportional to field strength. 0 G is denoted by 12'b0 value.	R	–

Temperature Sensor Output

The A1454 provides a 12-bit digital output that is proportional to the junction temperature of the Hall sensor IC.

Table 3: Temp Out [11:0], Address 0x1D, Bit Definition Table

Bits	Address	Name	Value	Description	R/W	Default
11:0	0x1D	Temp Out	0/1 (for each bit)	12-bit signed signal proportional to temperature. 25°C is denoted by a 12'b0 value. Temperature Slope is 8 LSB/°C(typ).	R	–

Sleep Mode

The A1454 supports a Sleep mode where numerous subsystems are unpowered. To enter Sleep mode, the user sets the Sleep bit (see Table 4). To awake from Sleep mode, the user clears the Sleep bit. Since the I²C logic uses SCL as its clock source and the Sleep bit is implemented in the SCL clock domain, the system clock does not need to be operational for the Sleep output to be cleared. Within a period of about 50 μs (typ) after clearing the Sleep bit, the system clock will be operational, and the A1454 IC

will respond to I²C commands. Furthermore, within a period of about 150 μs (typ) after clearing the Sleep bit, the A1454 will be able to provide a digital output that is accurate, but not temperature compensated. Lastly, within a period of about 500 μs after clearing the Sleep bit, the A1454 will be able to provide an output value that meets device accuracy specifications.

Therefore, a design trade-off can be made between wake-up time and accuracy of output, based on the specific system-level requirements.

Table 4: Sleep [0], Address 0x20, Bit Definition Table

Bits	Address	Name	Value	Description	R/W	Default
0	0x20	Sleep	0/1	Sleep Mode Enable Bit	R/W	0

CHARACTERISTIC DEFINITIONS

Active Mode Response Time

The Active Mode Response Time, t_{ACTIVE} , is the time required to settle internal voltages with an applied magnetic field after either V_{CC} is above $V_{\text{CC}(\text{min})}$ or the command to activate from Sleep mode has been received. The I²C master can issue a command to activate the device from Sleep mode by clearing the SLEEP bit (0x20, D0). After the SLEEP bit has been cleared, the device requires a finite time to power-on its internal components before accurately responding to an applied magnetic field. When coming out of Sleep mode, the IC acts as if it is being powered on. All volatile registers are reset to their default values, and those registers which can be programmed into EEPROM are reloaded with what is in EEPROM.

Maximum Applied Field

The A1454 handles magnetic signals as large as B_{max} before internal amplifiers begin to saturate. Fields above these values will result in uncertain device operation outside specification limits.

LINEAR SENSITIVITY ERROR

The A1454 is designed to provide a linear output in response to a ramping applied magnetic field. Consider two magnetic fields, B1 and B2. Ideally, the sensitivity of a device is the same for both fields, for a given supply voltage and temperature. Linearity error is present when there is a difference between the sensitivities measured at B1 and B2.

Linearity Error is calculated separately for the positive (L_{inERRPOS}) and negative (L_{inERRNEG}) applied magnetic fields. Linearity Error (%) is measured and defined as:

$$Lin_{\text{ERRPOS}} = \left(1 - \frac{Sens_{\text{BPOS2}}}{Sens_{\text{BPOS1}}}\right) \times 100 (\%)$$

$$Lin_{\text{ERRNEG}} = \left(1 - \frac{Sens_{\text{BNEG2}}}{Sens_{\text{BNEG1}}}\right) \times 100 (\%)$$

where:

$$Sens_{\text{B}_x} = \frac{|V_{\text{OUT}(\text{B}_x)} - V_{\text{OUT}(\text{Q})}|}{B_x}$$

and B_{POS_x} and B_{NEG_x} are positive and negative magnetic fields, with respect to the quiescent voltage output such that $|B_{\text{POS}_2}| = 2 \times |B_{\text{POS}_1}|$ and $|B_{\text{NEG}_2}| = 2 \times |B_{\text{NEG}_1}|$. In the above equation, $V_{\text{OUT}(\text{Q})}$ is the quiescent voltage output, and $V_{\text{OUT}(\text{B}_x)}$ is the Hall voltage when the field, B_x , is applied.

Then:

$$Lin_{\text{ERR}} = \max(Lin_{\text{ERRPOS}}, Lin_{\text{ERRNEG}})$$

I²C Interface

This is a serial interface that uses two bus lines, SCL and SDA, to access the internal control registers. Data is exchanged between a microcontroller (master) and the A1454 (slave). The clock input to SCL is generated by the master, while the SDA line functions as either an input or an open drain output, depending on the direction of the data.

The I²C input thresholds depend on the V_{CC} voltage of the A1454. The threshold levels over the operating V_{CC} range are compatible with 3 V logic.

TIMING CONSIDERATIONS

I²C communication is composed of several steps in the following sequence:

1. Start Condition. Defined by a negative edge on the SDA line, while SCL is high.
2. Address Cycle. 7 bits of address, plus 1 bit to indicate write (0) or read (1), and an acknowledge bit.
3. Data Cycles. Reading or writing 8 bits of data followed by an acknowledge bit.
4. Stop Condition. Defined by a positive edge on the SDA line, while SCL is high.

Except to indicate a Start or Stop condition, SDA must be stable while the clock is high. SDA can only be changed while SCL is low. It is possible for the Start or Stop condition to occur at any time during a data transfer. The A1454 always responds by resetting the data transfer sequence.

The state of the Read/Write bit is set to 0 to indicate a write cycle and set to 1 to indicate a read cycle.

The master monitors for an acknowledge pulse to determine if the slave device is responding to the address byte sent to the A1454. When the A1454 decodes the 7-bit address field as a valid address, it responds by pulling SDA low during the ninth clock cycle.

During a data write from the master, the A1454 pulls SDA low during the clock cycle that follows the data byte, in order to indicate that the data has been successfully received.

After sending either an address byte or a data byte, the master device must release the SDA line before the ninth clock cycle, in order to allow the handshaking to occur.

I²C Command to Write to the A1454

The master controls the A1454 by programming it as a slave. To do so, the master transmits data bits to the SDA input of the A1454, in synchronization with the clocking signal the master transmits simultaneously on the SCL input.

A complete transmission begins with the master pulling SDA low (Start bit), and completes with the master releasing the SDA line (Stop bit). As shown in Figure 1, between these points, the master transmits two address bytes, the first with the A1454 (chip) address bits and a write command bit (D0 = 0) and the second with the initial target register address, which are followed by the data bytes. After every byte, regardless of byte payload, the slave

A1454 acknowledges by transmitting a low to the master on the SDA line.

Multiple data bytes can be written by one I²C sequence, as shown in Figure 2. After the slave acknowledges a data byte, instead of sending a Stop bit, the master sends the next data byte. Only after the final data byte is written and the slave acknowledges, does the master provide a Stop bit. The A1454 automatically directs each additional data byte to the next register, in order of register address number. Note that only the initial register address is required. This allows faster data entry, although it restricts data entry to sequential registers. If nonsequential registers are to be written, separate write commands can be sent.



Figure 2: I²C Write Operation

Customer Write Access

Before attempting to write to any of the serial registers or EEPROM memory locations in the A1454, an access code must be entered to put the device in customer access mode. If customer access mode is configured, then no writes to the device are allowed, with the exception of the SLEEP bit. Any register or EEPROM location can be read at any time regardless of the access mode.

To enter either customer access mode, an access command needs to be sent via the I²C interface. The command is simply a serial write operation with the address and data values as shown in Table 5. Once the access mode is set, it is not possible to change the mode without power-cycling the device. There is no time limit for entering the code.

Table 5: Customer Access Code

	Address	Data
Customer Access Mode	0x24	0x2C413534

I²C Command to Read from the A1454

The master can read back both volatile and nonvolatile EEPROM register values from the A1454. Similar to writing, the master transmits data bits to the SDA input of the A1454, in synchronization with the clocking signal the master transmits simultaneously on the SCL input.

A complete transmission consists of a read command from the master and a response from the A1454. It begins with the master pulling SDA low (Start bit), and completes with the master releasing the SDA line (Stop bit). As shown in Figure 3, between these points, the master transmits two address bytes, the first with the A1454 (chip) address bits and a write command bit (D0 = 0) and the second with the initial source register address. After each address byte, the slave A1454 acknowledges by transmitting a low to the master on the SDA line. The master then issues another Start bit (referred to as *restart*) followed by the same slave chip address and the Read/Write bit set to read (D0 = 1).

The A1454 then provides the data byte from the addressed register, synchronized with the clock pulse supplied by the master (the master must provide the clock pulses, as the A1454 slave does not have the capability to generate them).

In Figure 3, the transmission is of the entire contents of a single register location (bits 31:0). Optionally, the I²C master can continue to acknowledge instead of issuing a “NACK” and stopping. This will result in the transfer of data [31:24] from Reg Address+1. The master can then continue acknowledging or issue the “not acknowledge/stop” after any byte to stop receiving data. Note that only the initial register address is required. This allows faster data retrieval, although it restricts data retrieval to sequential registers. When the master provides non-acknowledge bit and Stop bit, the A1454 stops sending data. If nonsequential registers are to be read, separate read commands can be sent.

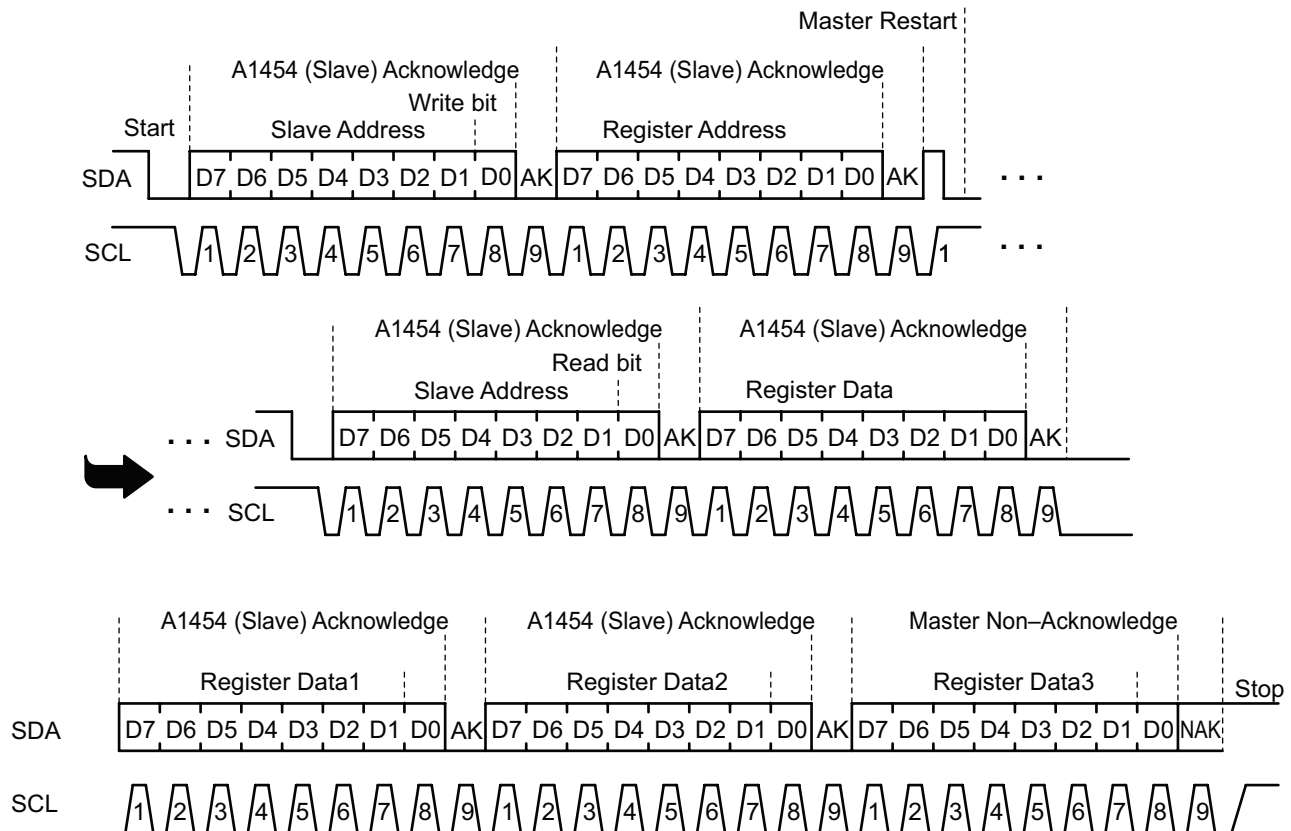

Figure 3: I²C Read Operation

I²C Address for the A1454

The default device address, in the case where VA0 and VA1 are set to V_{CC}, is given by binary 0000 000[0/1], where the last bit determines if it is a read or a write instruction. For more options on slave addressing for the A1454, refer to the section: I²C Device (Slave) Address Coding.

EEPROM Functionality

The on-chip EEPROM is divided into eight rows, each thirty-two bits long, with six of the MSBs being used for EEPROM ECC.

On power-up, all registers in EEPROM address 0x03 to 0x07 are loaded into the volatile registers which shadow them. For example, EE address 0x03 is loaded into registers 0x0C. The user can overwrite these volatile registers, and they will be reset to the values in the EEPROM only on a power-cycle of the IC.

Programming EEPROM Blocks

Programming of the EEPROM is done through the I²C interface. Each row of EEPROM can only be written 1000 times. The I²C command for writing to EEPROM is very similar to the general

I²C command for writing to the volatile serial registers in the A1454. Before attempting to write to EEPROM, ensure that the device is in Customer Access Mode. For more details, see the Customer Write Access section.

A complete transmission begins with the master pulling SDA low (Start bit), and completes with the master releasing the SDA line (Stop bit). As shown in Figure 4, between these points, the master transmits two address bytes, the first with the A1454 (chip) address bits and a write command bit (D0 = 0) and the second with the initial target EEPROM register address, which are followed by the data bytes. After every byte, regardless of byte payload, the slave A1454 acknowledges by transmitting a low to the master on the SDA line.

The 1454 always writes one entire EEPROM row at a time. As shown in Figure 4. After the slave acknowledges a data byte, the master sends the next data byte. Only after the final data byte is written and the slave acknowledges, does the master provide a Stop bit. The A1454 now takes these 4 data bytes and writes them to the requested register address. It takes the EEPROM 30 ms (typ) to perform the write command. After such time, the host can issue the next I²C EEPROM write command, if desired.

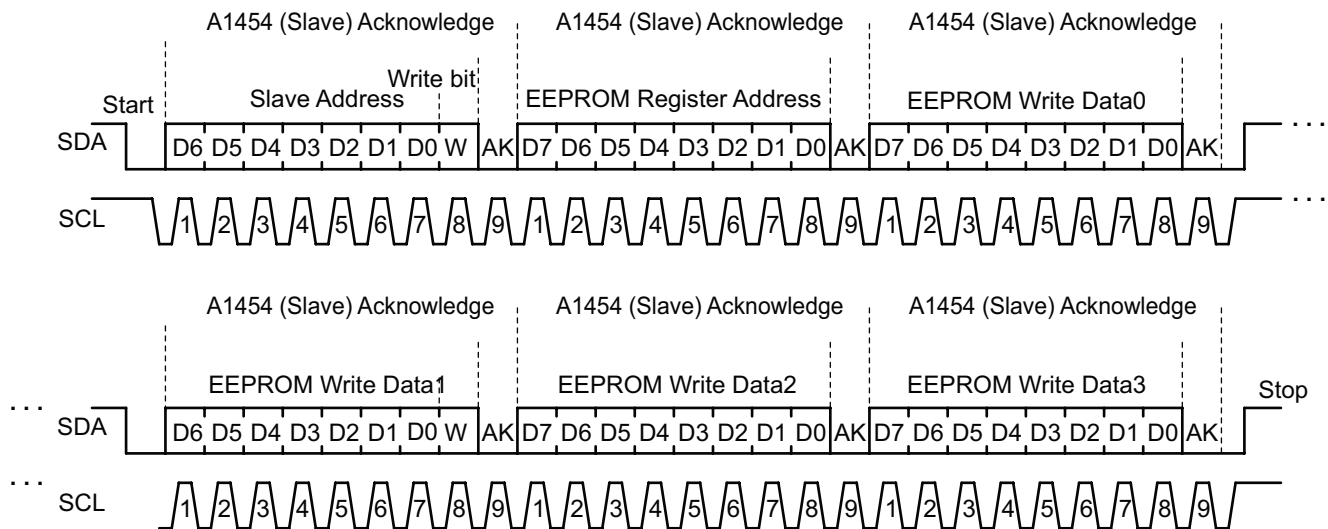

Figure 4: Programming EEPROM Blocks

This sequence enables programming of EEPROM blocks 2 through 3 from the volatile registers which shadow those blocks (see Table 11).

EEPROM Memory Check

The EEPROM Memory Check provides the capability to vary the EEPROM reference voltages and compare the data from each reference voltage, to ensure that no EEPROM memory cells are corrupt. A high reference voltage is used ensure that 1's are cor-

rectly programmed and a low reference voltage is used to ensure that the 0's are correctly programmed.

Table 6 and Table 7 describe the features available in customer-accessible register EEPROM Check.

Table 6: Customer-Accessible Register EEPROM Check

Register Name	Register Address	Bit Number						
		25:6	5	4	3	2	1	0
EEPROM Check	0x1C	Unused	MM	MS		0	0	MCI

Table 7: Customer-Accessible Register EEPROM Check

Parameter Name	Description	Value
MCI: Memory Check Initiate	The MCI bit initiates an EEPROM memory check. This bit self-clears upon completion of the memory test.	0: Reset Condition
		1: Start Memory Check
Bit 1	Must be set to '0'	0
Bit 2	Must be set to '0'	0
MS[1:0]: Memory Status	Status bits that provide information on the progress and result of the Memory Check. Cleared after a read or a system reset.	00: Reset Condition
		01: Pass – No failure detected.
		10: Fail – Failure detected
MM	In the case of MS [1:0] = [10], i.e. failure detected, MM will provide additional diagnostic information, indicating whether the failing memory reference was the low reference, or the high reference.	0: Low Reference Failed
		1: High Reference Failed

I²C Device (Slave) Address Coding

The four LSBs of the device (slave) address (A3, A2, A1, and A0) can be set by applying different voltages to pins ADR0 and ADR1; see Table 8 and Table 9.

Table 8: A1454 I²C Address Bits

Address Bit						
A6	A5	A4	A3	A2	A1	A0
Binary Device Address Value						
0/1	0/1	0/1	0/1	0/1	0/1	0/1

Table 9: Slave Address Decoding

Voltage on AD1 Pin, V _{A1} (÷ V _{CC})	Voltage on AD0 Pin, V _{A0} (÷ V _{CC})	4-bit Code from ADR0 and ADR1 Voltages				Slave Address Bits							Slave Address (decimal)
		E3	E2	E1	E0	A6	A5	A4	A3	A2	A1	A0	
0	0	0	0	0	0	1	1	0	0	0	0	0	96
	0.33	0	0	0	1	1	1	0	0	0	0	1	97
	0.67	0	0	1	0	1	1	0	0	0	1	0	98
	1	0	0	1	1	1	1	0	0	0	1	1	99
0.33	0	0	1	0	0	1	1	0	0	1	0	0	100
	0.33	0	1	0	1	1	1	0	0	1	0	1	101
	0.67	0	1	1	0	1	1	0	0	1	1	0	102
	1	0	1	1	1	1	1	0	0	1	1	1	103
0.67	0	1	0	0	0	1	1	0	1	0	0	0	104
	0.33	1	0	0	1	1	1	0	1	0	0	1	105
	0.67	1	0	1	0	1	1	0	1	0	1	0	106
	1	1	0	1	1	1	1	0	1	0	1	1	107
1	0	1	1	0	0	1	1	0	1	1	0	0	108
	0.33	1	1	1	0	1	1	0	1	1	1	0	109
	0.67	1	1	1	0	1	1	0	1	1	1	0	110
	1	1	1	1	1	X	X	X	X	X	X	X	Programmable: 0-127, (Using 7-bit EEPROM field). Set at factory for Default = 000

EEPROM Customer Space

Register 0x02 (Bits 25:0) are available as customer EEPROM space. This memory location is intended to be used by the user for storing information, such as factory time stamps, lot numbers and version numbers. This register is not shadowed, and so must be written 4 bytes at a time, as described in the Programming EEPROM section (second method). As with all the EEPROM registers, these registers can only be written 1000 times.

Table 10: EEPROM Memory Map

ADR	31	30	29	28	27	26	25	24	23	22	21	20	19	18	17	16	15	14	13	12	11	10	9	8	7	6	5	4	3	2	1	0
0x00	Auto ECC Bits						Factory Access Only																									
0x01	Auto ECC Bits						Factory Access Only																									
0x02	Auto ECC Bits						Customer Space																									
0x03	Auto ECC Bits						Test_Field_TBD														Cust_Slave_Address											
0x04	Auto ECC Bits						Factory Locked																									
0x05	Auto ECC Bits						Factory Locked																									
0x06	Auto ECC Bits						Factory Locked																									
0x07	Auto ECC Bits						Factory Locked																									

Table 11: Volatile Register That Shadow EEPROM (registers are loaded from EEPROM on power-up)

ADR	EEPROM Register	31	30	29	28	27	26	25	24	23	22	21	20	19	18	17	16	15	14	13	12	11	10	9	8	7	6	5	4	3	2	1	0
0x0B	03	Auto ECC Bits						Test_Field_TBD														Cust_Slave_Address											
0x0C	04	Auto ECC Bits						Factory Locked																									
0x0D	05	Auto ECC Bits						Factory Locked																									
0x0E	06	Auto ECC Bits						Factory Locked																									
0x0F	07	Auto ECC Bits						Factory Locked																									

PACKAGE OUTLINE DIAGRAM

For Reference Only – Not for Tooling Use

(Reference Allegro DWG-0000381, Rev. 1 and JEDEC MO-153AA)
 Dimensions in millimeters - NOT TO SCALE
 Dimensions exclusive of mold flash, gate burrs, and dambar protrusions
 Exact case and lead configuration at supplier discretion within limits shown

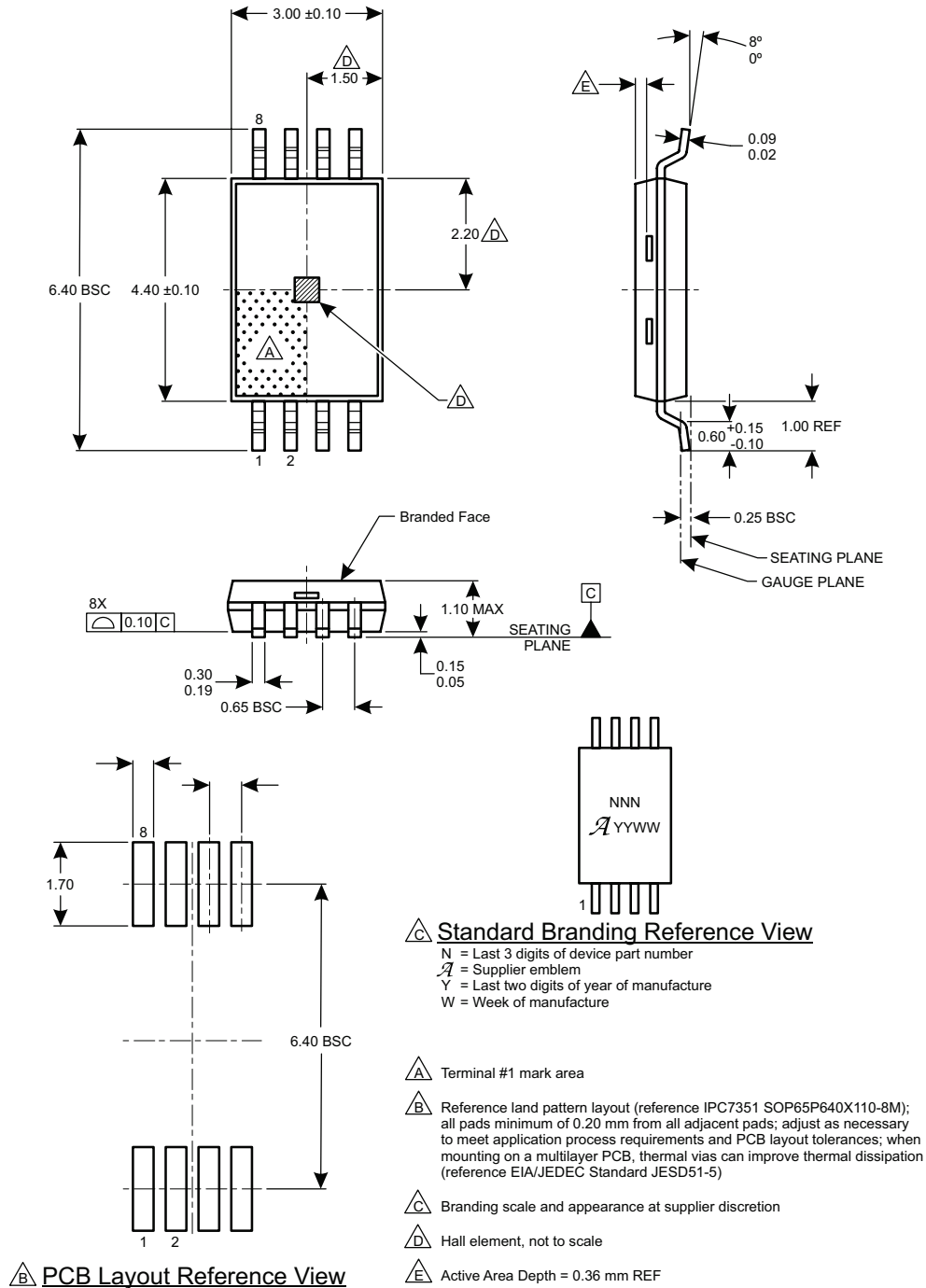

Figure 5: Package LE, 8-Pin TSSOP

Revision History

Number	Date	Description
–	April 3, 2015	Initial Release
1	May 17, 2016	Corrected Output Fall Time test conditions; updated I ² C Device (Slave) Address Coding and Sleep Mode default value; miscellaneous editorial changes.
2	February 13, 2019	Minor editorial updates
3	March 6, 2020	Minor editorial updates
4	March 3, 2022	Updated package drawing (page 14)

Copyright 2022, Allegro MicroSystems.

Allegro MicroSystems reserves the right to make, from time to time, such departures from the detail specifications as may be required to permit improvements in the performance, reliability, or manufacturability of its products. Before placing an order, the user is cautioned to verify that the information being relied upon is current.

Allegro's products are not to be used in any devices or systems, including but not limited to life support devices or systems, in which a failure of Allegro's product can reasonably be expected to cause bodily harm.

The information included herein is believed to be accurate and reliable. However, Allegro MicroSystems assumes no responsibility for its use; nor for any infringement of patents or other rights of third parties which may result from its use.



Copies of this document are considered uncontrolled documents.

For the latest version of this document, visit our website:

www.allegromicro.com

Looking for pricing, stock, or lifecycle information?

Click below to explore more details on WIN SOURCE:

-  [View A1454KLETR-2N-T on WIN SOURCE](#)
-  [Allegro MicroSystems, LLC Information](#)

Optimize Your Supply Chain with WIN SOURCE Solutions

-  Global Sourcing Solution
-  Obsolete Management
-  Cost Control Management
-  Shortage Management
-  Alternative Solution
-  Excess Inventory Management