



**THE DATASHEET OF
AD7834ANZ**



FEATURES

- Four 14-bit DACs in one package**
- AD7834—serial loading**
- AD7835—parallel 8-bit/14-bit loading**
- Voltage outputs**
- Power-on reset function**
- Maximum/minimum output voltage range of ± 8.192 V**
- Maximum output voltage span of 14 V**
- Common voltage reference inputs**
- User-assigned device addressing**
- Clear function to user-defined voltage**
- Surface-mount packages**
- AD7834—28-lead SOIC and PDIP**
- AD7835—44-lead MQFP and PLCC**

APPLICATIONS

- Process control**
- Automatic test equipment**
- General-purpose instrumentation**

GENERAL DESCRIPTION

The AD7834 and AD7835 contain four 14-bit DACs on one monolithic chip. The AD7834 and AD7835 have output voltages in the range ± 8.192 V with a maximum span of 14 V.

The AD7834 is a serial input device. Data is loaded in 16-bit format from the external serial bus, MSB first after two leading 0s,

into one via DIN, SCLK, and $\overline{\text{FSYNC}}$. The AD7834 has five dedicated package address pins, PA0 to PA4, that can be wired to AGND or V_{CC} to permit up to 32 AD7834s to be individually addressed in a multipackage application.

The AD7835 can accept either 14-bit parallel loading or double-byte loading, where right-justified data is loaded in one 8-bit byte and one 6-bit byte. Data is loaded from the external bus into one of the input latches under the control of the $\overline{\text{WR}}$, $\overline{\text{CS}}$, $\overline{\text{BYSHF}}$, and DAC channel address pins, A0 to A2.

With each device, the $\overline{\text{LDAC}}$ signal is used to update all four DAC outputs simultaneously, or individually, on reception of new data. In addition, for each device, the asynchronous $\overline{\text{CLR}}$ input can be used to set all signal outputs, $V_{\text{OUT}1}$ to $V_{\text{OUT}4}$, to the user-defined voltage level on the device sense ground pin, DSG. On power-on, before the power supplies have stabilized, internal circuitry holds the DAC output voltage levels to within ± 2 V of the DSG potential. As the supplies stabilize, the DAC output levels move to the exact DSG potential (assuming $\overline{\text{CLR}}$ is exercised).

The AD7834 is available in a 28-lead 0.3" SOIC package and a 28-lead 0.6" PDIP package, and the AD7835 is available in a 44-lead MQFP package and a 44-lead PLCC package.

FUNCTIONAL BLOCK DIAGRAMS

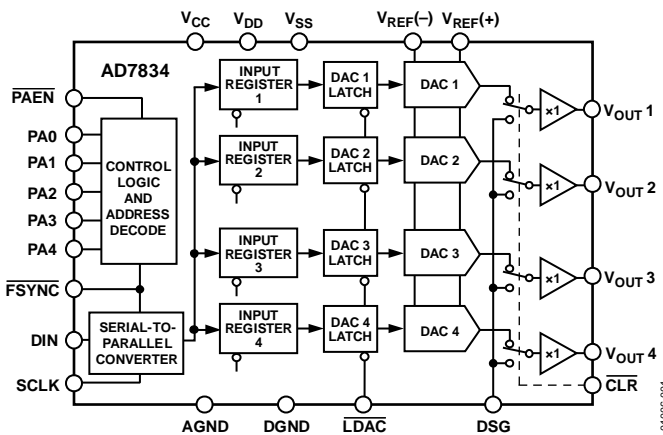

Figure 1. AD7834

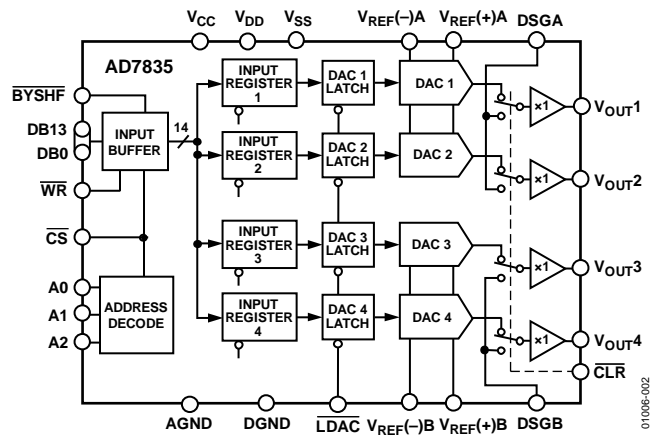

Figure 2. AD7835

Rev. D

Information furnished by Analog Devices is believed to be accurate and reliable. However, no responsibility is assumed by Analog Devices for its use, nor for any infringements of patents or other rights of third parties that may result from its use. Specifications subject to change without notice. No license is granted by implication or otherwise under any patent or patent rights of Analog Devices. Trademarks and registered trademarks are the property of their respective owners.

TABLE OF CONTENTS

Features	1	Power-On with $\overline{\text{CLR}}$ Low, $\overline{\text{LDAC}}$ High	17
Applications.....	1	Power-On with $\overline{\text{LDAC}}$ Low, $\overline{\text{CLR}}$ High	17
General Description	1	Loading the DAC and Using the $\overline{\text{CLR}}$ Input	17
Functional Block Diagrams.....	1	DSG Voltage Range.....	18
Revision History	2	Power-On of the AD7834/AD7835.....	19
Specifications.....	3	Microprocessor Interfacing.....	20
AC Performance Characteristics	5	AD7834 to 80C51 Interface	20
Timing Specifications	6	AD7834 to 68HC11 Interface	20
Absolute Maximum Ratings.....	7	AD7834 to ADSP-2101 Interface	20
Thermal Resistance	7	AD7834 to DSP56000/DSP56001 Interface.....	21
ESD Caution.....	7	AD7834 to TMS32020/TMS320C25 Interface.....	21
Pin Configurations and Function Descriptions	8	Interfacing the AD7835—16-Bit Interface.....	21
Typical Performance Characteristics	11	Interfacing the AD7835—8-Bit Interface.....	22
Terminology	13	Applications Information	23
Theory of Operation	14	Serial Interface to Multiple AD7834s	23
DAC Architecture.....	14	Opto-Isolated Interface	23
Data Loading—AD7834 Serial Input Device	14	Automated Test Equipment	23
Data Loading—AD7835 Parallel Loading Device	14	Power Supply Bypassing and Grounding.....	24
Unipolar Configuration.....	15	Outline Dimensions	25
Bipolar Configuration.....	16	Ordering Guide	27
Controlled Power-On of the Output Stage.....	17		

REVISION HISTORY

8/07—Rev. C to Rev. D

Changes to Table 5	7
Added Table 6.....	7
Changes to Table 8.....	9
Updated Outline Dimensions	25
Changes to Ordering Guide	27

7/05—Rev. B to Rev. C

Updated Format.....	Universal
Changes to Figure 40.....	25
Changes to Ordering Guide	27

7/03—Rev. A to Rev. B

Revision 0: Initial Version

SPECIFICATIONS

$V_{CC} = 5\text{ V} \pm 5\%$; $V_{DD} = 15\text{ V} \pm 5\%$; $V_{SS} = -15\text{ V} \pm 5\%$; $AGND = DGND = 0\text{ V}$; $T_A^1 = T_{MIN}$ to T_{MAX} , unless otherwise noted.

Table 1.

Parameter	A	B	S	Unit	Test Conditions/Comments
ACCURACY					
Resolution	14	14	14	Bits	
Relative Accuracy	± 2	± 1	± 2	LSB max	
Differential Nonlinearity	± 0.9	± 0.9	± 0.9	LSB max	Guaranteed monotonic over temperature.
Full-Scale Error					$V_{REF(+)} = +7\text{ V}$, $V_{REF(-)} = -7\text{ V}$.
T_{MIN} to T_{MAX}	± 5	± 5	± 8	mV max	
Zero-Scale Error	± 4	± 4	± 5	mV max	$V_{REF(+)} = +7\text{ V}$, $V_{REF(-)} = -7\text{ V}$.
Gain Error	± 0.5	± 0.5	± 0.5	mV typ	$V_{REF(+)} = +7\text{ V}$, $V_{REF(-)} = -7\text{ V}$.
Gain Temperature Coefficient ²	4	4	4	ppm FSR/ $^{\circ}\text{C}$ typ	
	20	20	20	ppm FSR/ $^{\circ}\text{C}$ max	
DC Crosstalk ²	50	50	50	μV max	See the Terminology section. $R_L = 10\text{ k}\Omega$.
REFERENCE INPUTS					
DC Input Resistance	30	30	30	$\text{M}\Omega$ typ	
Input Current	± 1	± 1	± 1	μA max	Per input.
$V_{REF(+)}$ Range	0/8.192	0/8.192	0/8.192	V min/max	
$V_{REF(-)}$ Range	-8.192/0	-8.192/0	-8.192/0	V min/max	
$V_{REF(+)} - V_{REF(-)}$	5/14	7/14	5/14	V min/max	For specified performance. Can go as low as 0V, but performance is not guaranteed.
DEVICE SENSE GROUND INPUTS					
Input Current	± 2	± 2	± 2	μA max	Per input. $V_{DSG} = -2\text{ V}$ to $+2\text{ V}$.
DIGITAL INPUTS					
V_{INH} , Input High Voltage	2.4	2.4	2.4	V min	
V_{INL} , Input Low Voltage	0.8	0.8	0.8	V max	
I_{INH} , Input Current	± 10	± 10	± 10	μA max	
C_{IN} , Input Capacitance	10	10	10	pF max	
POWER REQUIREMENTS					
V_{CC}	5.0	5.0	5.0	V nom	$\pm 5\%$ for specified performance.
V_{DD}	15.0	15.0	15.0	V nom	$\pm 5\%$ for specified performance.
V_{SS}	-15.0	-15.0	-15.0	V nom	$\pm 5\%$ for specified performance.
Power Supply Sensitivity					
$\Delta\text{Full Scale}/\Delta V_{DD}$	110	110	110	dB typ	
$\Delta\text{Full Scale}/\Delta V_{SS}$	100	100	100	dB typ	
I_{CC}	0.2	0.2	0.5	mA max	$V_{INH} = V_{CC}$, $V_{INL} = \text{DGND}$.
	3	3	3	mA max	AD7834: $V_{INH} = 2.4\text{ V}$ min, $V_{INL} = 0.8\text{ V}$ max.
	6	6	6	mA max	AD7835: $V_{INH} = 2.4\text{ V}$ min, $V_{INL} = 0.8\text{ V}$ max.
I_{DD}	13	13	15	mA max	AD7834: outputs unloaded.
	15	15	15	mA max	AD7835: outputs unloaded.
I_{SS}	13	13	15	mA max	Outputs unloaded.

¹ Temperature range for A, B, and C versions is -40°C to $+85^{\circ}\text{C}$.

² Guaranteed by design.

AD7834/AD7835

$V_{CC} = 5\text{ V} \pm 5\%$; $V_{DD} = 12\text{ V} \pm 5\%$; $V_{SS} = -12\text{ V} \pm 5\%$; $AGND = DGND = 0\text{ V}$; $T_A^1 = T_{MIN}$ to T_{MAX} , unless otherwise noted.

Table 2.

Parameter	A	B	S	Unit	Test Conditions/Comments
ACCURACY					
Resolution	14	14	14	Bits	
Relative Accuracy	± 2	± 1	± 2	LSB max	
Differential Nonlinearity	± 0.9	± 0.9	± 0.9	LSB max	Guaranteed monotonic over temperature.
Full-Scale Error					$V_{REF(+)} = +5\text{ V}$, $V_{REF(-)} = -5\text{ V}$.
T_{MIN} to T_{MAX}	± 5	± 5	± 8	mV max	
Zero-Scale Error	± 4	± 4	± 5	mV max	$V_{REF(+)} = +5\text{ V}$, $V_{REF(-)} = -5\text{ V}$.
Gain Error	± 0.5	± 0.5	± 0.5	mV typ	$V_{REF(+)} = +5\text{ V}$, $V_{REF(-)} = -5\text{ V}$.
Gain Temperature Coefficient ²	4	4	4	ppm FSR/ $^{\circ}\text{C}$ typ	
	20	20	20	ppm FSR/ $^{\circ}\text{C}$ max	
DC Crosstalk ²	50	50	50	μV max	See the Terminology section. $R_L = 10\text{ k}\Omega$.
REFERENCE INPUTS					
DC Input Resistance	30	30	30	$\text{M}\Omega$ typ	
Input Current	± 1	± 1	± 1	μA max	Per input.
$V_{REF(+)}$ Range	0/8.192	0/8.192	0/8.192	V min/max	
$V_{REF(-)}$ Range	-5/0	-5/0	-5/0	V min/max	
$V_{REF(+)} - V_{REF(-)}$	5/13.192	7/13.192	5/13.192	V min/max	For specified performance. Can go as low as 0 V, but performance is not guaranteed.
DEVICE SENSE GROUND INPUTS					
Input Current	± 2	± 2	± 2	μA max	Per input. $V_{DSG} = -2\text{ V}$ to $+2\text{ V}$.
DIGITAL INPUTS					
V_{INH} , Input High Voltage	2.4	2.4	2.4	V min	
V_{INL} , Input Low Voltage	0.8	0.8	0.8	V max	
I_{INH} , Input Current	± 10	± 10	± 10	μA max	
C_{IN} , Input Capacitance	10	10	10	pF max	
POWER REQUIREMENTS					
V_{CC}	5.0	5.0	5.0	V nom	$\pm 5\%$ for specified performance.
V_{DD}	15.0	15.0	15.0	V nom	$\pm 5\%$ for specified performance.
V_{SS}	-15.0	-15.0	-15.0	V nom	$\pm 5\%$ for specified performance.
Power Supply Sensitivity					
Δ Full Scale/ ΔV_{DD}	110	110	110	dB typ	
Δ Full Scale/ ΔV_{SS}	100	100	100	dB typ	
I_{CC}	0.2	0.2	0.5	mA max	$V_{INH} = V_{CC}$, $V_{INL} = DGND$.
	3	3	3	mA max	AD7834: $V_{INH} = 2.4\text{ V}$ min, $V_{INL} = 0.8\text{ V}$ max.
	6	6	6	mA max	AD7835: $V_{INH} = 2.4\text{ V}$ min, $V_{INL} = 0.8\text{ V}$ max.
I_{DD}	13	13	15	mA max	AD7834: outputs unloaded.
	15	15	15	mA max	AD7835: outputs unloaded.
I_{SS}	13	13	15	mA max	Outputs unloaded.

¹ Temperature range for A, B, and C versions is -40°C to $+85^{\circ}\text{C}$.

² Guaranteed by design.

AC PERFORMANCE CHARACTERISTICS

These characteristics are included for design guidance and are not subject to production testing.

Table 3.

Parameter	A	B	S	Unit (typ)	Test Conditions/Comments
DYNAMIC PERFORMANCE					
Output Voltage Settling Time	10	10	10	μ s	Full-scale change to $\pm 1/2$ LSB. DAC latch contents alternately loaded with all 0s and all 1s.
Digital-to-Analog Glitch Impulse	120	120	120	nV-s	Measured with $V_{REF(+)} = V_{REF(-)} = 0$ V. DAC latch alternately loaded with all 0s and all 1s.
DC Output Impedance	0.5	0.5	0.5	Ω	See the Terminology section.
Channel-to-Channel Isolation	100	100	100	dB	See the Terminology section; applies to the AD7835 only.
DAC-to-DAC Crosstalk	25	25	25	nV-s	See the Terminology section.
Digital Crosstalk	3	3	3	nV-s	Feedthrough to DAC output under test due to change in digital input code to another converter.
Digital Feedthrough—AD7834	0.2	0.2	0.2	nV-s	Effect of input bus activity on DAC output under test.
Digital Feedthrough—AD7835	1.0	1.0	1.0	nV-s	
Output Noise Spectral Density at 1 kHz	40	40	40	nV/ \sqrt Hz	All 1s loaded to DAC. $V_{REF(+)} = V_{REF(-)} = 0$ V.

AD7834/AD7835

TIMING SPECIFICATIONS

$V_{CC} = 5\text{ V} \pm 5\%$; $V_{DD} = 11.4\text{ V}$ to 15.75 V ; $V_{SS} = -11.4\text{ V}$ to -15.75 V ; $AGND = DGND = 0\text{ V}^1$.

Table 4.

Parameter	Limit at T_{MIN}, T_{MAX}	Unit	Description
AD7834-SPECIFIC			
t_1^2	100	ns min	SCLK cycle time
t_2^2	50	ns min	SCLK low
t_3^2	30	ns min	SCLK high time
t_4	30	ns min	\overline{FSYNC} , PAEN setup time
t_5	40	ns min	\overline{FSYNC} , PAEN hold time
t_6	30	ns min	Data setup time
t_7	10	ns min	Data hold time
t_8	0	ns min	\overline{LDAC} to \overline{FSYNC} setup time
t_9	40	ns min	\overline{LDAC} to \overline{FSYNC} hold time
t_{21}	20	ns min	Delay between write operations
AD7835-SPECIFIC			
t_{11}	15	ns min	A0, A1, A2, \overline{BYSHF} to \overline{CS} setup time
t_{12}	15	ns min	A0, A1, A2, \overline{BYSHF} to \overline{CS} hold time
t_{13}	0	ns min	\overline{CS} to \overline{WR} setup time
t_{14}	0	ns min	\overline{CS} to \overline{WR} hold time
t_{15}	40	ns min	\overline{WR} pulse width
t_{16}	40	ns min	Data setup time
t_{17}	10	ns min	Data hold time
t_{18}	0	ns min	\overline{LDAC} to \overline{CS} setup time
t_{19}	0	ns min	\overline{CS} to \overline{LDAC} setup time
t_{20}	0	ns min	\overline{LDAC} to \overline{CS} hold time
GENERAL			
t_{10}	40	ns min	\overline{LDAC} , \overline{CLR} pulse width

¹ All input signals are specified with $t_r = t_f = 5\text{ ns}$ (10% to 90% of 5 V) and time from a voltage level of 1.6 V.

² Rise and fall times should be no longer than 50 ns.

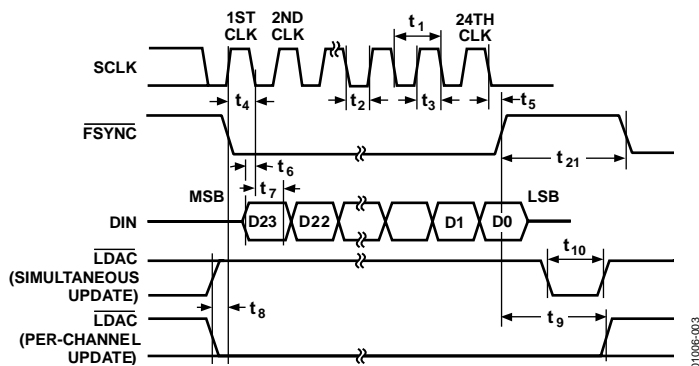

Figure 3. AD7834 Timing Diagram

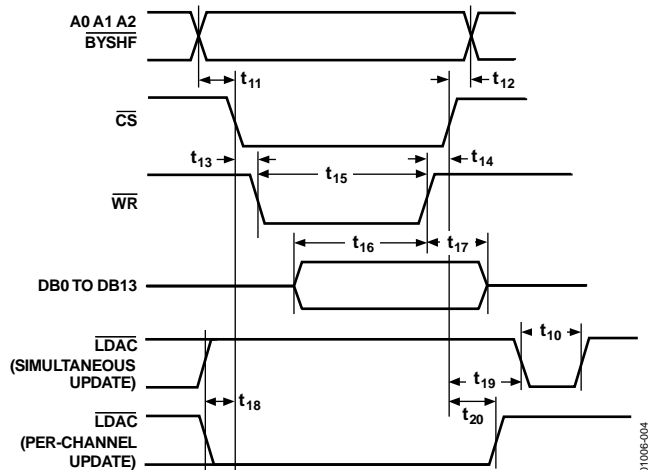

Figure 4. AD7835 Timing Diagram

ABSOLUTE MAXIMUM RATINGS

$T_A = 25^\circ\text{C}$ unless otherwise noted. Transient currents of up to 100 mA do not cause SCR latch-up. V_{CC} must not exceed V_{DD} by more than 0.3 V. If it is possible for this to happen during power supply sequencing, the diode protection scheme shown in Figure 5 can be used to provide protection.

Table 5.

Parameter	Rating
V_{CC} to DGND	-0.3 V to +7 V, or $V_{DD} + 0.3$ V (whichever is lower)
V_{DD} to AGND	-0.3 V to +17 V
V_{SS} to AGND	+0.3 V to -17 V
AGND to DGND	-0.3 V to +0.3 V
Digital Inputs to DGND	-0.3 V to $V_{CC} + 0.3$ V
$V_{REF(+)}$ to $V_{REF(-)}$	-0.3 V to +18 V
$V_{REF(+)}$ to AGND	$V_{SS} - 0.3$ V to $V_{DD} + 0.3$ V
$V_{REF(-)}$ to AGND	$V_{SS} - 0.3$ V to $V_{DD} + 0.3$ V
DSG to AGND	$V_{SS} - 0.3$ V to $V_{DD} + 0.3$ V
V_{OUT} (1-4) to AGND	$V_{SS} - 0.3$ V to $V_{DD} + 0.3$ V
Operating Temperature Range, T_A	
Industrial (A Version)	-40°C to +85°C
Storage Temperature Range	-65°C to +150°C
Junction Temperature, T_J (max)	150°C
Power Dissipation, P_D (max)	$(T_J - T_A)/\theta_{JA}$
Lead Temperature	JEDEC Industry Standard
Soldering	J-STD-020

Stresses above those listed under Absolute Maximum Ratings may cause permanent damage to the device. This is a stress rating only; functional operation of the device at these or any other conditions above those indicated in the operational section of this specification is not implied. Exposure to absolute maximum rating conditions for extended periods may affect device reliability.

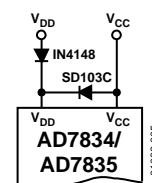

Figure 5. Diode Protection

THERMAL RESISTANCE

θ_{JA} is specified for the worst-case conditions, that is, a device soldered in a circuit board for surface-mount packages.

Table 6. Thermal Resistance

Package Type	θ_{JA}	Unit
PDIP	75	°C/W
SOIC	75	°C/W
MQFP	95	°C/W
PLCC	55	°C/W

ESD CAUTION



ESD (electrostatic discharge) sensitive device. Charged devices and circuit boards can discharge without detection. Although this product features patented or proprietary protection circuitry, damage may occur on devices subjected to high energy ESD. Therefore, proper ESD precautions should be taken to avoid performance degradation or loss of functionality.

PIN CONFIGURATIONS AND FUNCTION DESCRIPTIONS

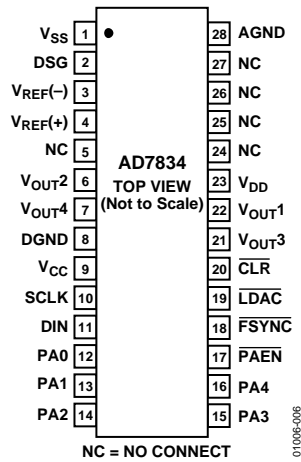

Figure 6. AD7834 PDIP and SOIC Pin Configuration

Table 7. AD7834 Pin Function Descriptions

Pin No.	Pin Mnemonic	Description
1	V _{SS}	Negative Analog Power Supply: $-15\text{ V} \pm 5\%$ or $-12\text{ V} \pm 5\%$.
2	DSG	Device Sense Ground Input. Used in conjunction with the $\overline{\text{CLR}}$ input for power-on protection of the DACs. When $\overline{\text{CLR}}$ is low, the DAC outputs are forced to the potential on the DSG pin.
3	V _{REF(-)}	Negative Reference Input. The negative reference voltage is referred to AGND.
4	V _{REF(+)}	Positive Reference Input. The positive reference voltage is referred to AGND.
5, 24, 25, 26, 27	NC	No Connect.
22, 6, 21, 7	V _{OUT1} to V _{OUT4}	DAC Outputs.
8	DGND	Digital Ground.
9	V _{CC}	Logic Power Supply: $5\text{ V} \pm 5\%$.
10	SCLK	Clock Input. Used for writing data to the device; data is clocked into the input register on the falling edge of SCLK.
11	DIN	Serial Data Input.
12,13,14,15,16	PA0 to PA4	Package Address Inputs. These inputs are hardwired high (V _{CC}) or low (DGND) to assign dedicated package addresses in a multipackage environment.
17	$\overline{\text{PAEN}}$	Package Address Enable Input. When low, this input allows normal operation of the device. When high, the device ignores the package address, but not the channel address, in the serial data stream and loads the serial data into the input registers. This feature is useful in a multipackage application where it can be used to load the same data into the same channel in each package.
18	$\overline{\text{FSYNC}}$	Frame Sync Input. Active low logic input used, in conjunction with DIN and SCLK, to write data to the device with serial data expected after the falling edge of this signal. The contents of the 24-bit serial-to-parallel input register are transferred on the rising edge of this signal.
19	$\overline{\text{LDAC}}$	Load DAC Input (Level Sensitive). This input signal, in conjunction with the $\overline{\text{FSYNC}}$ input signal, determines how the analog outputs are updated. If $\overline{\text{LDAC}}$ is maintained high while new data is being loaded into the device's input registers, no change occurs on the analog outputs. Subsequently, when $\overline{\text{LDAC}}$ is brought low, the contents of all four input registers are transferred into their respective DAC latches, updating all of the analog outputs simultaneously.
20	$\overline{\text{CLR}}$	Asynchronous Clear Input (Level Sensitive, Active Low). When this input is brought low, all analog outputs are switched to the externally set potential on the DSG pin. When $\overline{\text{CLR}}$ is brought high, the signal outputs remain at the DSG potential until $\overline{\text{LDAC}}$ is brought low. When $\overline{\text{LDAC}}$ is brought low, the analog outputs are switched back to reflect their individual DAC output levels. As long as $\overline{\text{CLR}}$ remains low, the $\overline{\text{LDAC}}$ signals are ignored, and the signal outputs remain switched to the potential on the DSG pin.
23	V _{DD}	Positive Analog Power Supply: $15\text{ V} \pm 5\%$ or $12\text{ V} \pm 5\%$.
28	AGND	Analog Ground.

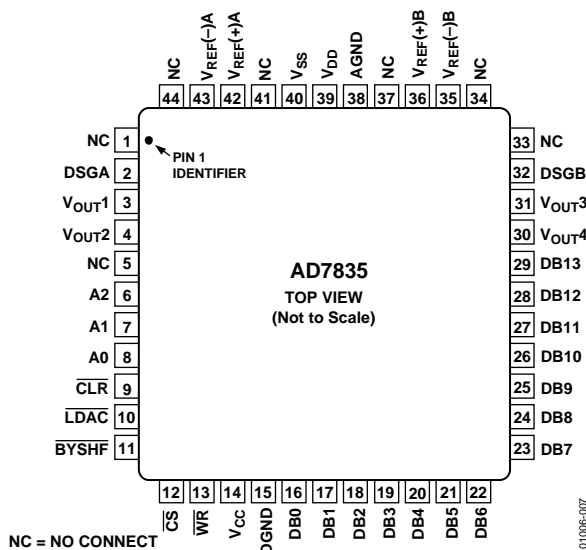

Figure 7. AD7835 MQFP Pin Configuration

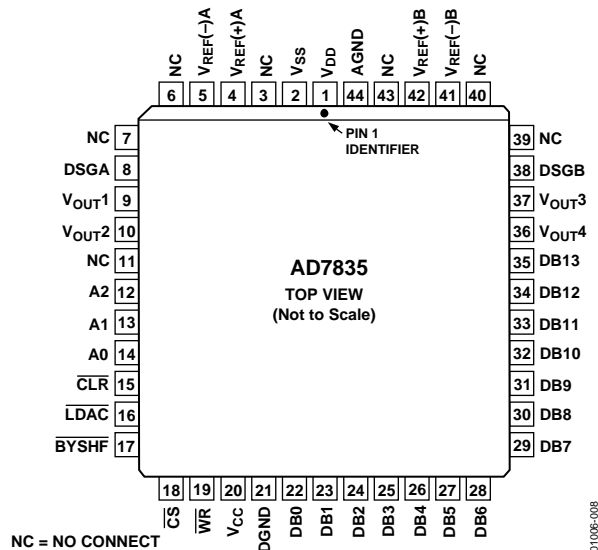

Figure 8. AD7835 PLCC Pin Configuration

Table 8. AD7835 Pin Function Descriptions

Pin No. MQFP	Pin No. PLCC	Pin Mnemonic	Description
1, 5, 33, 34, 37, 41, 44	3, 6, 7, 11, 39, 40, 43	NC	No Connect.
2	8	DSGA	Device Sense Ground A Input. Used in conjunction with the $\overline{\text{CLR}}$ input for power-on protection of the DACs. When $\overline{\text{CLR}}$ is low, DAC outputs V_{OUT1} and V_{OUT2} are forced to the potential on the DSGA pin.
3, 4, 31, 30, 8, 7, 6	9, 10, 37, 36, 14, 13, 12	V_{OUT1} to V_{OUT4} A0, A1, A2	DAC Outputs. Address Inputs. A0 and A1 are decoded to select one of the four input latches for a data transfer. A2 is used to select all four DACs simultaneously.
9	15	$\overline{\text{CLR}}$	Asynchronous Clear Input (Level Sensitive, Active Low). When this input is brought low, all analog outputs are switched to the externally set potentials on the DSG pins (V_{OUT1} and V_{OUT2} follow DSGA, and V_{OUT3} and V_{OUT4} follow DSGB). When $\overline{\text{CLR}}$ is brought high, the signal outputs remain at the DSG potentials until $\overline{\text{LDAC}}$ is brought low. When $\overline{\text{LDAC}}$ is brought low, the analog outputs are switched back to reflect their individual DAC output levels. As long as $\overline{\text{CLR}}$ remains low, the $\overline{\text{LDAC}}$ signals are ignored, and the signal outputs remain switched to the potential on the DSG pins.
10	16	$\overline{\text{LDAC}}$	Load DAC Input (Level Sensitive). This input signal, in conjunction with the $\overline{\text{WR}}$ and $\overline{\text{CS}}$ input signals, determines how the analog outputs are updated. If $\overline{\text{LDAC}}$ is maintained high while new data is being loaded into the device's input registers, no change occurs on the analog outputs. Subsequently, when $\overline{\text{LDAC}}$ is brought low, the contents of all four input registers are transferred into their respective DAC latches, updating the analog outputs simultaneously. Alternatively, if $\overline{\text{LDAC}}$ is brought low while new data is being entered, the addressed DAC latch and corresponding analog output are updated immediately on the rising edge of $\overline{\text{WR}}$.
11	17	$\overline{\text{BYSHF}}$	Byte Shift Input. When low, it shifts the data on DB0 to DB7 into the DB8 to DB13 half of the input register.
12	18	$\overline{\text{CS}}$	Level-Triggered Chip Select Input (Active Low). The device is selected when this input is low.
13	19	$\overline{\text{WR}}$	Level-Triggered Write Input (Active Low). When active, it is used in conjunction with $\overline{\text{CS}}$ to write data over the input databus.
14	20	V_{CC}	Logic Power Supply: $5\text{ V} \pm 5\%$.
15	21	DGND	Digital Ground.

AD7834/AD7835

Pin No. MQFP	Pin No. PLCC	Pin Mnemonic	Description
16 to 29	22 to 35	DB0 to DB13	Parallel Data Inputs. The AD7835 can accept a straight 14-bit parallel word on DB0 to DB13, where DB13 is the MSB and the $\overline{\text{BYSHF}}$ input is hardwired to a logic high. Alternatively for byte loading, the bottom eight data inputs, DB0 to DB7, are used for data loading, and the top six data inputs, DB8 to DB13, should be hardwired to a logic low. The $\overline{\text{BYSHF}}$ control input selects whether 8 LSBs or 6 MSBs of data are being loaded into the device.
32	38	DSGB	Device Sense Ground B Input. Used in conjunction with the $\overline{\text{CLR}}$ input for power-on protection of the DACs. When $\overline{\text{CLR}}$ is low, DAC outputs $V_{\text{OUT}3}$ and $V_{\text{OUT}4}$ are forced to the potential on the DSGB pin.
36, 35	42, 41	$V_{\text{REF}(+)B}$, $V_{\text{REF}(-)B}$	Reference Inputs for DACs 3 and 4. These reference voltages are referred to AGND.
38	44	AGND	Analog Ground.
39	1	V_{DD}	Positive Analog Power Supply: $15\text{ V} \pm 5\%$ or $12\text{ V} \pm 5\%$.
40	2	V_{SS}	Negative Analog Power Supply: $-15\text{ V} \pm 5\%$ or $-12\text{ V} \pm 5\%$.
42, 43	4, 5	$V_{\text{REF}(+)A}$, $V_{\text{REF}(-)A}$	Reference Inputs for DAC 1 and DAC 2. These reference voltages are referred to AGND.

TYPICAL PERFORMANCE CHARACTERISTICS

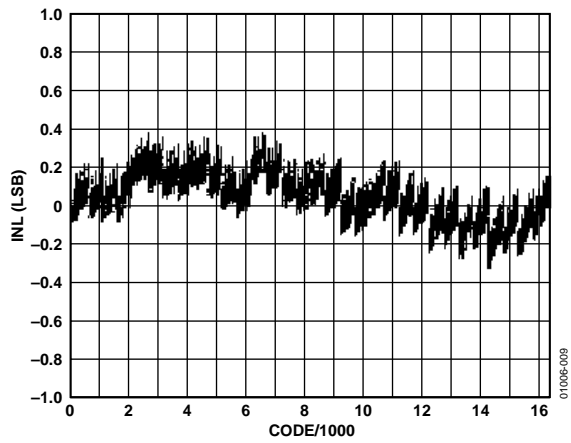

Figure 9. Typical INL Plot

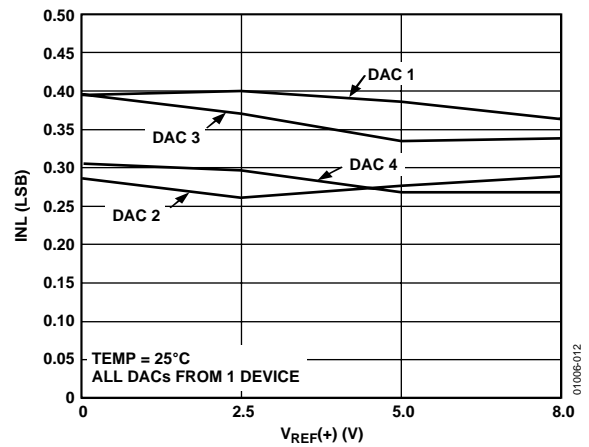

Figure 12. Typical INL vs. $V_{REF(+)}$, $V_{REF(+)} - V_{REF(-)} = 5\text{ V}$

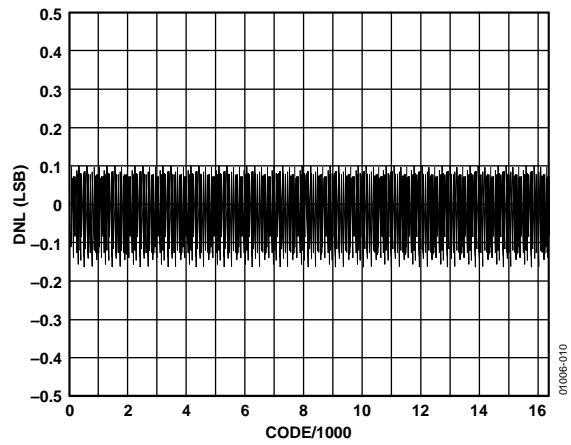

Figure 10. Typical DNL Plot

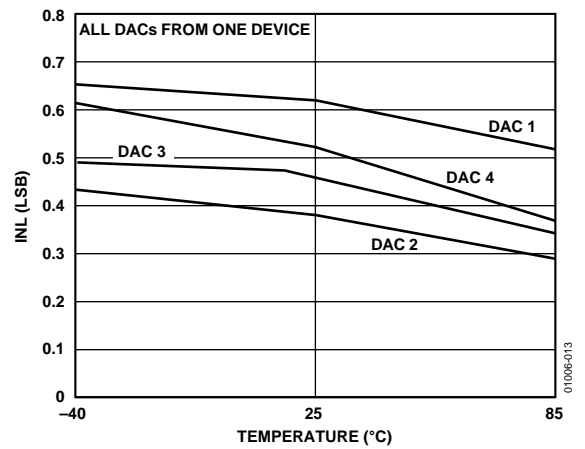

Figure 13. Typical INL vs. Temperature

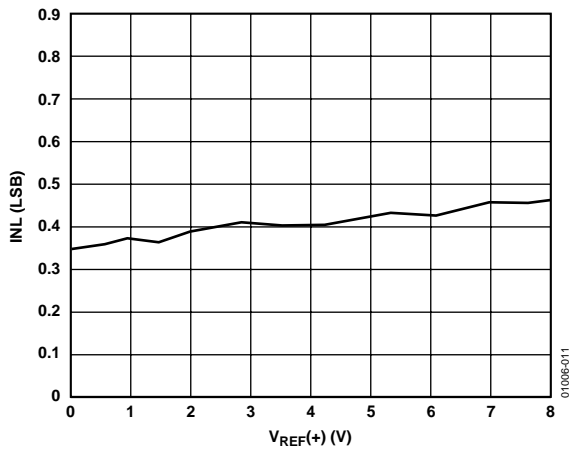

Figure 11. Typical INL vs. $V_{REF(+)}$, $V_{REF(-)} = -6\text{ V}$

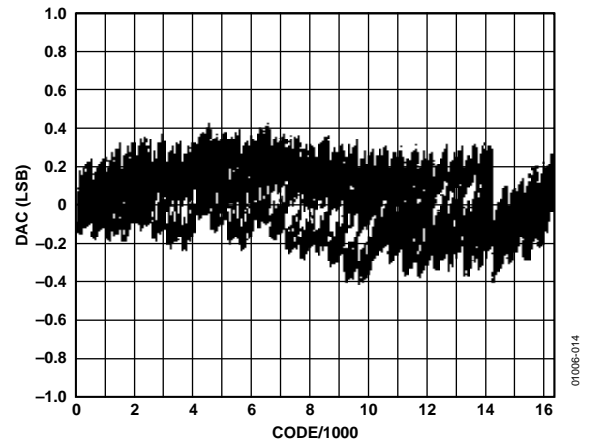

Figure 14. Typical DAC-to-DAC Matching

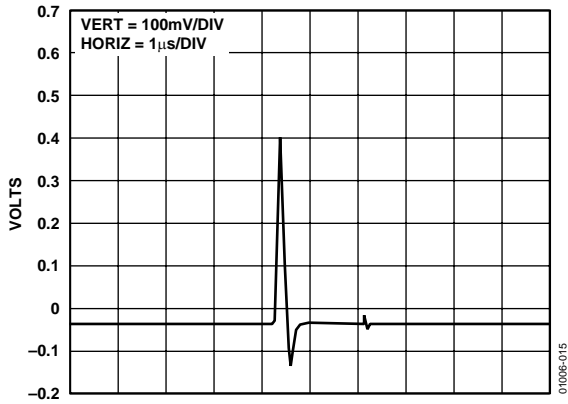

Figure 15. Typical Digital/Analog Glitch Impulse

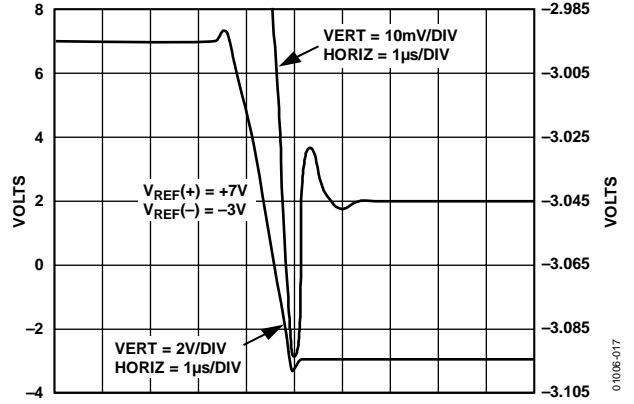

Figure 17. Settling Time(-)

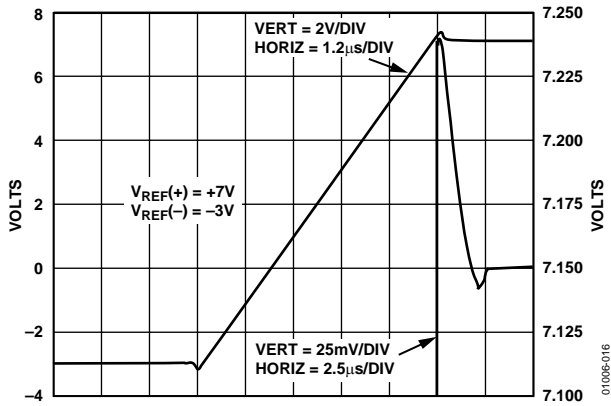

Figure 16. Settling Time(+)

TERMINOLOGY

Relative Accuracy

Relative accuracy or endpoint linearity is a measure of the maximum deviation from a straight line passing through the endpoints of the DAC transfer function. It is measured after adjusting for zero error and full-scale error. It is normally expressed in LSBs or as a percentage of full-scale reading.

Differential Nonlinearity

Differential nonlinearity is the difference between the measured change and the ideal 1 LSB change between any two adjacent codes. A specified differential nonlinearity of 1 LSB maximum ensures monotonicity.

DC Crosstalk

Although the common input reference (IR) voltage signals are internally buffered, small IR drops in individual DAC reference inputs across the die mean that an update to one channel produces a dc output change in one or more channel outputs.

The four DAC outputs are buffered by op amps sharing common V_{DD} and V_{SS} power supplies. If the dc load current changes in one channel due to an update, a further dc change occurs in one or more of the channel outputs. This effect is most obvious at high load currents and is reduced as the load currents are reduced. With high impedance loads, the effect is virtually unmeasurable.

Output Voltage Settling Time

This is the amount of time it takes for the output to settle to a specified level for a full-scale input change.

Digital-to-Analog Glitch Impulse

This is the amount of charge injected into the analog output when the inputs change state. It is specified as the area of the glitch in nV-secs. It is measured with the reference inputs connected to 0 V and the digital inputs toggled between all 1s and all 0s.

Channel-to-Channel Isolation

Channel-to-channel isolation refers to the proportion of input signal from the reference input of one DAC that appears at the output of the other DAC. It is expressed in decibels (dB). The AD7834 has no specification for channel-to-channel isolation because it has one reference for all DACs. Channel-to-channel isolation is specified for the AD7835.

DAC-to-DAC Crosstalk

DAC-to-DAC crosstalk is defined as the glitch impulse that appears at the output of one converter due to both the digital change and the subsequent analog output (O/P) change at another converter. It is specified in nV-secs.

Digital Crosstalk

The glitch impulse transferred to the output of one converter due to a change in digital input code to the other converter is defined as the digital crosstalk and is specified in nV-secs.

Digital Feedthrough

When the device is not selected, high frequency logic activity on its digital inputs can be capacitively coupled both across and through the device to show up as noise on the V_{OUT} pins. This noise is digital feedthrough.

DC Output Impedance

DC output impedance is the effective output source resistance. It is dominated by package lead resistance.

Full-Scale Error

Full-scale error is the error in DAC output voltage when all 1s are loaded into the DAC latch. Ideally, the output voltage, with all 1s loaded into the DAC latch, should be $V_{REF(+)} - 1$ LSB. Full-scale error does not include zero-scale error.

Zero-Scale Error

Zero-scale error is the error in the DAC output voltage when all 0s are loaded into the DAC latch. Ideally, the output voltage, with all 0s in the DAC latch, is equal to $V_{REF(-)}$. Zero-scale error is due mainly to offsets in the output amplifier.

Gain Error

Gain error is defined as (full-scale error) – (zero-scale error).

THEORY OF OPERATION

DAC ARCHITECTURE

Each channel consists of a segmented 14-bit R-2R voltage-mode DAC. The full-scale output voltage range is equal to the entire reference span of $V_{REF(+)} - V_{REF(-)}$. The DAC coding is straight binary; all 0s produce an output of $V_{REF(-)}$; all 1s produce an output of $V_{REF(+)} - 1$ LSB.

The analog output voltage of each DAC channel reflects the contents of its own DAC latch. Data is transferred from the external bus to the input register of each DAC latch on a per channel basis. The AD7835 has a feature whereby the A2 pin data can be transferred from the input databus to all four input registers simultaneously.

Bringing the \overline{CLR} line low switches all the signal outputs, V_{OUT1} to V_{OUT4} , to the voltage level on the DSG pin. The signal outputs are held at this level after the removal of the \overline{CLR} signal and do not switch back to the DAC outputs until the \overline{LDAC} signal is exercised.

DATA LOADING—AD7834 SERIAL INPUT DEVICE

A write operation transfers 24 bits of data to the AD7834. The first 8 bits are control data and the remaining 16 bits are DAC data (see Figure 18). The control data identifies the DAC channel to be updated with new data and which of 32 possible packages the DAC resides in. In any communication with the device, the first 8 bits must always be control data.

The DAC output voltages, V_{OUT1} to V_{OUT4} , can be updated to reflect new data in the DAC input registers in one of two ways. The first method normally keeps \overline{LDAC} high and only pulses \overline{LDAC} low momentarily to update all DAC latches simultaneously with the contents of their respective input registers. The second method ties \overline{LDAC} low and channel updating occurs on a per channel basis after new data has been clocked into the AD7834. With \overline{LDAC} low, the rising edge of \overline{FSYNC} transfers the new data directly into the DAC latch, updating the analog output voltage.

Data being shifted into the AD7834 enters a 24-bit long shift register. If more than 24 bits are clocked in before \overline{FSYNC} goes high, the last 24 bits transmitted are used as the control data and DAC data.

Individual bit functions are shown in Figure 18.

D23

D23 determines whether the following 23 bits of address and data should be used or ignored. This is effectively a software chip select bit. D23 is the first bit to be transmitted in the 24-bit long word.

Table 9. D23 Control

D23	Control Function
0	Ignore the following 23 bits of information.
1	Use the following 23 bits of address and data as normal.

D22 and D21

D22 and D21 are decoded to select one of the four DAC channels within a device, as shown in Table 10.

Table 10. D22, D21 Control

D22	D21	Control Function
0	0	Select Channel 1
0	1	Select Channel 2
1	0	Select Channel 3
1	1	Select Channel 4

D20 to D16

D20 and D16 determine the package address. The five address bits allow up to 32 separate packages to be individually decoded. Successful decoding is accomplished when these five bits match up with the five hardwired pins on the physical package.

D15 to D0

D15 and D0 provide DAC data to be loaded into the identified DAC input register. This data must have two leading 0s followed by 14 bits of data, MSB first. The MSB is in location D13 of the 24-bit data stream.

DATA LOADING—AD7835 PARALLEL LOADING DEVICE

Data is loaded into the AD7835 in either straight 14-bit wide words or in two 8-bit bytes.

In systems that transfer 14-bit wide data, the \overline{BYSHF} input should be hardwired to V_{CC} . This sets up the AD7835 as a straight 14-bit parallel-loading DAC.

In 8-bit bus systems where it is required to transfer data in two bytes, it is necessary to have the \overline{BYSHF} input under logic control. In such a system, the top six pins of the device databus, DB8 to DB13, must be hardwired to DGND. New low byte data is loaded into the lower eight places of the selected input register by carrying out a write operation while holding \overline{BYSHF} high. A second write operation is subsequently executed with \overline{BYSHF} low and the 6 MSBs on the DB0 to DB5 inputs (DB5 = MSB).

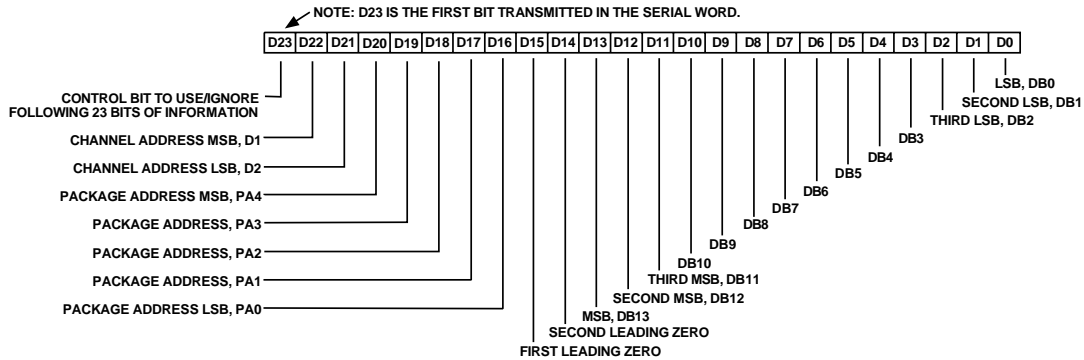

Figure 18. Bit Assignments for 24-Bit Data Stream of AD7834

When 14-bit transfers are being used, the DAC output voltages, V_{OUT1} to V_{OUT4} , can be updated to reflect new data in the DAC input registers in one of two ways. The first method normally keeps \overline{LDAC} high and only pulses \overline{LDAC} low momentarily to update all DAC latches simultaneously with the contents of their respective input registers. The second method ties \overline{LDAC} low, and channel updating occurs on a per channel basis after new data is loaded to an input register.

To avoid the DAC output going to an intermediate value during a 2-byte transfer, \overline{LDAC} should not be tied low permanently but should be held high until the two bytes are written to the input register. When the selected input register has been loaded with the two bytes, \overline{LDAC} should then be pulsed low to update the DAC latch and, consequently, perform the digital-to-analog conversion.

In many applications, it may be acceptable to allow the DAC output to go to an intermediate value during a 2-byte transfer. In such applications, \overline{LDAC} can be tied low, thus using one less control line.

The actual DAC input register that is being written to is determined by the logic levels present on the device address lines, as shown in Table 11.

Table 11. AD7835—Address Line Truth Table

A2	A1	A0	DAC Selected
0	0	0	DAC 1
0	0	1	DAC 2
0	1	0	DAC 3
0	1	1	DAC 4
1	X	X	All DACs selected

UNIPOLAR CONFIGURATION

Figure 19 shows the AD7834/AD7835 in the unipolar binary circuit configuration. The $V_{REF(+)}$ input of the DAC is driven by the AD586, a 5 V reference. $V_{REF(-)}$ is tied to ground. Table 12

gives the code table for unipolar operation of the AD7834/AD7835.

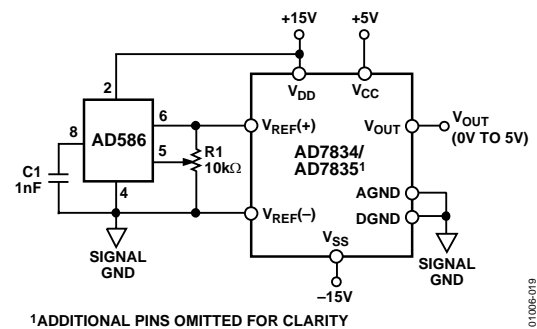

Figure 19. Unipolar 5 V Operation

Offset and gain can be adjusted in Figure 19 as follows:

- To adjust offset, disconnect the $V_{REF(-)}$ input from 0 V, load the DAC with all 0s, and adjust the $V_{REF(-)}$ voltage until $V_{OUT} = 0$ V.
- To adjust gain, load the AD7834/AD7835 with all 1s and adjust R1 until $V_{OUT} = 5$ V ($16383/16384$) = 4.999695 V.

Many circuits do not require these offset and gain adjustments. In these circuits, R1 can be omitted. Pin 5 of the AD586 can be left open circuit, and Pin 2 ($V_{REF(-)}$) of the AD7834/AD7835 is tied to 0 V.

Table 12. Code Table for Unipolar Operation^{1, 2}

Binary Number in DAC Latch				Analog Output (V_{OUT})
MSB			LSB	
11	1111	1111	1111	V_{REF} (16383/16384) V
10	0000	0000	0000	V_{REF} (8192/16384) V
01	1111	1111	1111	V_{REF} (8191/16384) V
00	0000	0000	0001	V_{REF} (1/16384) V
00	0000	0000	0000	0 V

¹ $V_{REF} = V_{REF(+)}$; $V_{REF(-)} = 0$ V for unipolar operation.

² For $V_{REF(+)} = 5$ V, 1 LSB = 5 V/ 2^{14} = 5 V/16384 = 305 μ V.

AD7834/AD7835

BIPOLAR CONFIGURATION

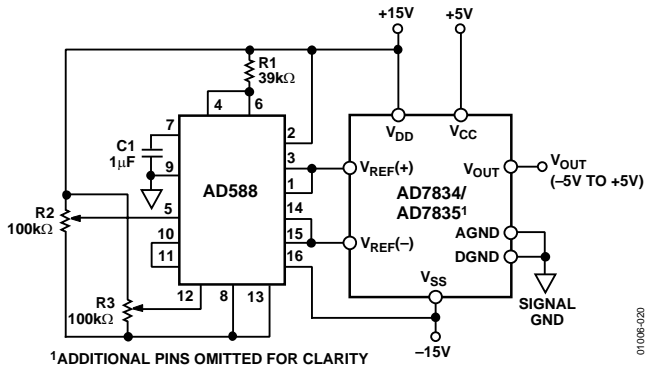

Figure 20. Bipolar ± 5 V Operation

Figure 20 shows the AD7834/AD7835 setup for ± 5 V operation. The AD588 provides precision ± 5 V tracking outputs that are fed to the $V_{REF(+)}$ and $V_{REF(-)}$ inputs of the AD7834/AD7835. The code table for bipolar operation of the AD7834/AD7835 is shown in Table 13.

Table 13. Code Table for Bipolar Operation^{1, 2}

Binary Number in DAC Latch				Analog Output (V_{OUT})
MSB	LSB			
11	1111	1111	1111	$V_{REF(-)} + V_{REF}$ (16383/16384) V
10	0000	0000	0001	$V_{REF(-)} + V_{REF}$ (8193/16384) V
10	0000	0000	0000	$V_{REF(-)} + V_{REF}$ (8192/16384) V
01	1111	1111	1111	$V_{REF(-)} + V_{REF}$ (8191/16384) V
00	0000	0000	0001	$V_{REF(-)} + V_{REF}$ (1/16384) V
00	0000	0000	0000	$V_{REF(-)}$ V

¹ $V_{REF} = V_{REF(+)} - V_{REF(-)}$.

² For $V_{REF(+)} = +5$ V and $V_{REF(-)} = -5$ V, 1 LSB = 10 V/ 2^{14} = 10 V/16384 = 610 μ V.

In Figure 20, full-scale and bipolar zero adjustments are provided by varying the gain and balance on the AD588. R2 varies the gain on the AD588 while R3 adjusts the offset of both the +5 V and -5 V outputs together with respect to ground.

For bipolar-zero adjustment, the DAC is loaded with 1000 . . . 0000 and R3 is adjusted until $V_{OUT} = 0$ V. Full scale is adjusted by loading the DAC with all 1s and adjusting R2 until $V_{OUT} = 5(8191/8192)$ V = 4.99939 V.

When bipolar zero and full-scale adjustment are not needed, R2 and R3 are omitted. Pin 12 on the AD588 should be connected to Pin 11, and Pin 5 should be left floating.

CONTROLLED POWER-ON OF THE OUTPUT STAGE

A block diagram of the output stage of the AD7834/AD7835 is shown in Figure 21. It is capable of driving a load of 10 k Ω in parallel with 200 pF. G_1 to G_6 are transmission gates used to control the power-on voltage present at V_{OUT} . G_1 and G_2 are also used in conjunction with the \overline{CLR} input to set V_{OUT} to the user-defined voltage present at the DSG pin.

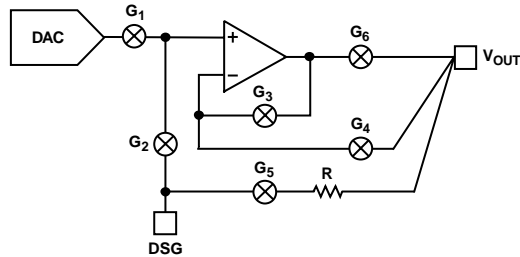

Figure 21. Block Diagram of AD7834/AD7835 Output Stage

POWER-ON WITH \overline{CLR} LOW, \overline{LDAC} HIGH

The output stage of the AD7834/AD7835 is designed to allow output stability during power-on. If \overline{CLR} is kept low during power-on, and power is applied to the part, G_1 , G_4 , and G_6 are open while G_2 , G_3 , and G_5 are closed (see Figure 22).

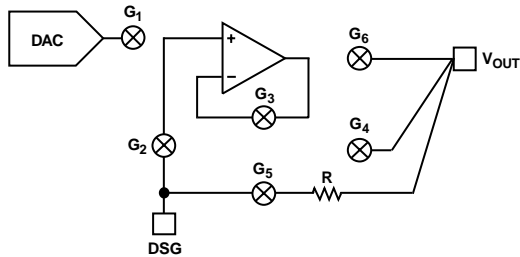

Figure 22. Output Stage with $V_{DD} < 10$ V

V_{OUT} is kept within a few hundred millivolts of DSG via G_5 and R . R is a thin-film resistor between DSG and V_{OUT} . The output amplifier is connected as a unity gain buffer via G_3 , and the DSG voltage is applied to the buffer input via G_2 . The amplifier output is thus at the same voltage as the DSG pin. The output stage remains configured as in Figure 22 until the voltage at V_{DD} and V_{SS} reaches approximately ± 10 V. At this point, the output amplifier has enough headroom to handle signals at its input and has also had time to settle. The internal power-on circuitry opens G_3 and G_5 and closes G_4 and G_6 (see Figure 23). As a result, the output amplifier is connected in unity gain mode via G_4 and G_6 . The DSG voltage is still applied to the noninverting input via G_2 . This voltage appears at V_{OUT} .

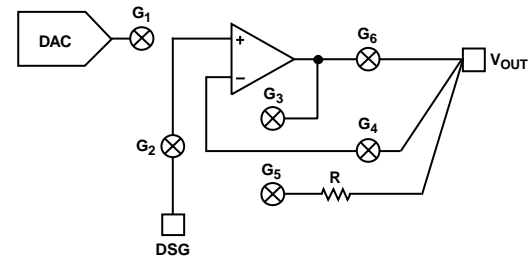

Figure 23. Output Stage with $V_{DD} > 10$ V and \overline{CLR} Low

V_{OUT} is disconnected from the DSG pin by the opening of G_5 but tracks the voltage present at DSG via the unity gain buffer.

POWER-ON WITH \overline{LDAC} LOW, \overline{CLR} HIGH

In many applications of the AD7834/AD7835, \overline{LDAC} is kept continuously low, updating the DAC after each valid data transfer. If \overline{LDAC} is low when power is applied, G_1 is closed and G_2 is open, connecting the output of the DAC to the input of the output amplifier. G_3 and G_5 are closed and G_4 and G_6 are open, connecting the amplifier as a unity gain buffer, as before. V_{OUT} is connected to DSG via G_5 and R (a thin-film resistance between DSG and V_{OUT}) until V_{DD} and V_{SS} reach approximately ± 10 V. Then, the internal power-on circuitry opens G_3 and G_5 and closes G_4 and G_6 . This is the situation shown in Figure 24. At this point, V_{OUT} is at the same voltage as the DAC output.

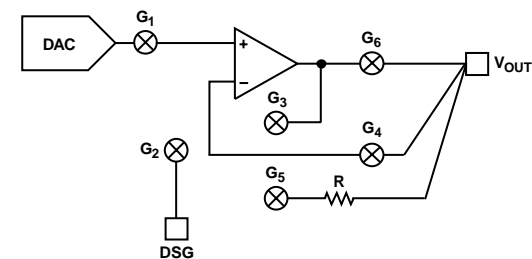

Figure 24. Output Stage with \overline{LDAC} Low

LOADING THE DAC AND USING THE \overline{CLR} INPUT

When \overline{LDAC} goes low, it closes G_1 and opens G_2 as in Figure 24. The voltage at V_{OUT} now follows the voltage present at the output of the DAC. The output stage remains connected in this manner until a \overline{CLR} signal is applied. Then, the situation reverts (see Figure 23). Once again, V_{OUT} remains at the same voltage as DSG until \overline{LDAC} goes low. This reconnects the DAC output to the unity gain buffer.

AD7834/AD7835

DSG VOLTAGE RANGE

During power-on, the V_{OUT} pins of the AD7834/AD7835 are connected to the relevant DSG pins via G_6 and the thin-film resistor, R . The DSG potential must obey the maximum ratings at all times. Thus, the voltage at DSG must always be within the range $V_{SS} - 0.3 \text{ V}$ to $V_{DD} + 0.3 \text{ V}$. However, to keep the voltages at the V_{OUT} pins of the AD7834/AD7835 within $\pm 2 \text{ V}$ of the relevant DSG potential during power-on, the voltage applied to DSG should also be kept within the range $AGND - 2 \text{ V}$ to $AGND + 2 \text{ V}$.

Once the AD7834/AD7835 have powered on and the on-chip amplifiers have settled, the situation is as shown in Figure 23. Any voltage subsequently applied to the DSG pin is buffered by the same amplifier that buffers the DAC output voltage in normal operation. Thus, for specified operations, the maximum voltage applied to the DSG pin increases to the maximum allowable $V_{REF(+)}$ voltage, and the minimum voltage applied to DSG is the minimum $V_{REF(-)}$ voltage. After the AD7834 or AD7835 has fully powered on, the outputs can track any DSG voltage within this minimum/maximum range.

POWER-ON OF THE AD7834/AD7835

Power is normally applied to the AD7834/AD7835 in the following sequence: first V_{DD} and V_{SS} , then V_{CC} , and then $V_{REF(+)}$ and $V_{REF(-)}$. The V_{REF} pins are not allowed to float when power is applied to the part. $V_{REF(+)}$ is not allowed to go below $V_{REF(-)} - 0.3$ V. $V_{REF(-)}$ is not allowed to go below $V_{SS} - 0.3$ V. V_{DD} is not allowed to go below $V_{CC} - 0.3$ V.

In some systems, it is necessary to introduce one or more Schottky diodes between pins to prevent the above situations arising at power-on. These diodes are shown in Figure 25. However, in most systems, with careful consideration given to power supply sequencing, the above rules are adhered to, and protection diodes are not necessary.

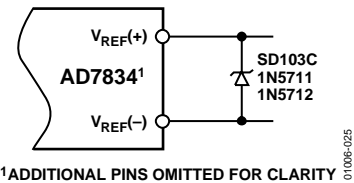

¹ADDITIONAL PINS OMITTED FOR CLARITY

01106E-025

Figure 25. Power-On Protection

MICROPROCESSOR INTERFACING

AD7834 TO 80C51 INTERFACE

A serial interface between the AD7834 and the 80C51 microcontroller is shown in Figure 26. TXD of the 80C51 drives SCLK of the AD7834, while RXD drives the serial data line of the part.

The 80C51 provides the LSB of its SBUF register as the first bit in the serial data stream. The AD7834 expects the MSB of the 24-bit write first. Therefore, the user has to ensure that data in the SBUF register is arranged correctly so the data is received MSB first by the AD7834/AD7835. When data is to be transmitted to the part, P3.3 is taken low. Data on RXD is valid on the falling edge of TXD. The 80C51 transmits its data in 8-bit bytes with only eight falling clock edges occurring in the transmit cycle. To load data to the AD7834, P3.3 is left low after the first 8 bits are transferred. A second byte is then transferred, with P3.3 still kept low. After the third byte has been transferred, the P3.3 line is taken high.

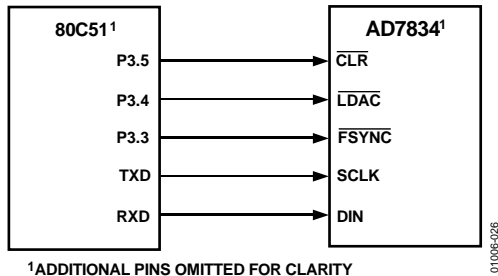

Figure 26. AD7834 to 80C51 Interface

$\overline{\text{LDAC}}$ and $\overline{\text{CLR}}$ on the AD7834 are also controlled by 80C51 port outputs. The user can bring $\overline{\text{LDAC}}$ low after every three bytes have been transmitted to update the DAC, which has been programmed. Alternatively, it is possible to wait until all the input registers have been loaded (12-byte transmits) and then update the DAC outputs.

AD7834 TO 68HC11 INTERFACE

Figure 27 shows a serial interface between the AD7834 and the 68HC11 microcontroller. SCK of the 68HC11 drives SCLK of the AD7834, while the MOSI output drives the serial data line, DIN, of the AD7834. The FSYNC signal is derived from Port Line PC7.

For correct operation of this interface, the 68HC11 should be configured so that its CPOL bit is 0 and its CPHA bit is 1. When data is to be transferred to the part, PC7 is taken low. When the 68HC11 is configured like this, data on MOSI is valid on the falling edge of SCK. The 68HC11 transmits its serial data in 8-bit bytes, MSB first. The AD7834 also expects the MSB of the 24-bit write first. Eight falling clock edges occur in the transmit cycle.

To load data to the AD7834, PC7 is left low after the first eight bits are transferred. A second byte of data is then transmitted serially to the AD7834. Then, a third byte is transmitted and, when this transfer is complete, the PC7 line is taken high.

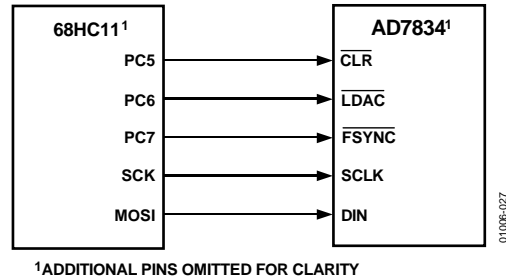

Figure 27. AD7834 to 68HC11 Interface

In Figure 27, $\overline{\text{LDAC}}$ and $\overline{\text{CLR}}$ are controlled by the PC6 and PC5 port outputs, respectively. As with the 80C51, each DAC of the AD7834 can be updated after each 3-byte transfer, or all DACs can be simultaneously updated after 12 bytes are transferred.

AD7834 TO ADSP-2101 INTERFACE

An interface between the AD7834 and the ADSP-2101 is shown in Figure 28. In the interface shown, SPORT0 is used to transfer data to the part. SPORT1 is configured for alternate functions. FO, the flag output on SPORT0, is connected to $\overline{\text{LDAC}}$ and is used to load the DAC latches. In this way, data is transferred from the ADSP-2101 to all the input registers in the DAC, and the DAC latches are updated simultaneously. In the application shown, the $\overline{\text{CLR}}$ pin on the AD7834 is controlled by circuitry that monitors the power in the system.

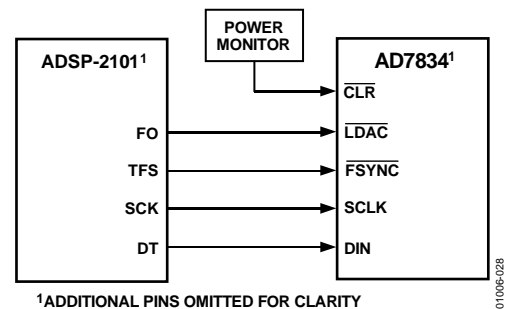

Figure 28. AD7834 to ADSP-2101 Interface

The AD7834 requires 24 bits of serial data framed by a single FSYNC pulse. It is necessary that this FSYNC pulse stay low until all the data is transferred. This can be provided by the ADSP-2101 in one of two ways. Both require setting the serial word length of the SPORT to 12 bits, with the following conditions: internal SCLK, alternate framing mode, and active low framing signal.

First, data can be transferred using the autobuffering feature of the ADSP-2101, sending two 12-bit words directly after each other. This ensures a continuous transmit frame synchronization (TFS) pulse. Second, the first data word is loaded to the serial port, the subsequent generated interrupt is trapped, and then the second data word is sent immediately after the first. Again, this produces a continuous TFS pulse that frames the 24 data bits.

AD7834 TO DSP56000/DSP56001 INTERFACE

Figure 29 shows a serial interface between the AD7834 and the DSP56000/DSP56001. The serial port is configured for a word length of 24 bits, gated clock, and FSL0 and FSL1 control bits each set to 0. Normal mode synchronous operation is selected, which allows the use of SC0 and SC1 as outputs controlling CLR and LDAC, respectively. The framing signal on SC2 has to be inverted before being applied to FSYNC. SCK is internally generated on the DSP56000/DSP56001 and is applied to SCLK on the AD7834. Data from the DSP56000/DSP56001 is valid on the falling edge of SCK.

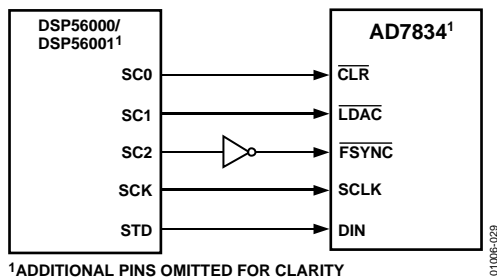

Figure 29. AD7834 to DSP56000/DSP56001 Interface

AD7834 TO TMS32020/TMS320C25 INTERFACE

A serial interface between the AD7834 and the TMS32020/TMS320C25 DSP processor is shown in Figure 30. The CLKX and FSX signals for the TMS32020/TMS32025 are generated using an external clock/timer circuit. The CLKX and FSX pins are configured as inputs. The TMS32020/TMS320C25 are set up for an 8-bit serial data length. Data can then be written to the AD7834 by writing three bytes to the serial port of the TMS32020/TMS320C25. In the configuration shown in Figure 30, the CLR input on the AD7834 is controlled by the XF output on the TMS32020/TMS320C25. The clock/timer circuit controls the LDAC input on the AD7834. Alternatively, LDAC can also be tied to ground to allow automatic update of the DAC latches after each transfer.

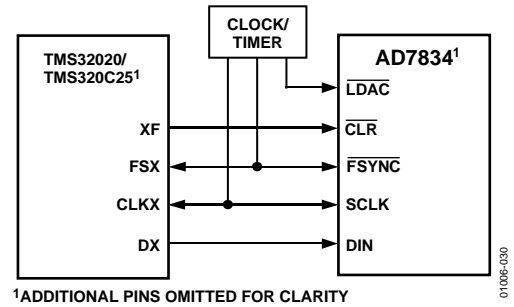

Figure 30. AD7834 to TMS32020/TMS320C25 Interface

INTERFACING THE AD7835—16-BIT INTERFACE

The AD7835 can be interfaced to a variety of microcontrollers or DSP processors, both 8-bit and 16-bit. Figure 31 shows the AD7835 interfaced to a generic 16-bit microcontroller/DSP processor. BYSHF is tied to V_{CC} in this interface. The lower address lines from the processor are connected to A0, A1, and A2 on the AD7835 as shown. The upper address lines are decoded to provide a chip select signal for the AD7835. They are also decoded, in conjunction with the lower address lines if need be, to provide an LDAC signal. Alternatively, LDAC can be driven by an external timing circuit or just tied low. The data lines of the processor are connected to the data lines of the AD7835. Selection options available for the DACs are provided in Table 11.

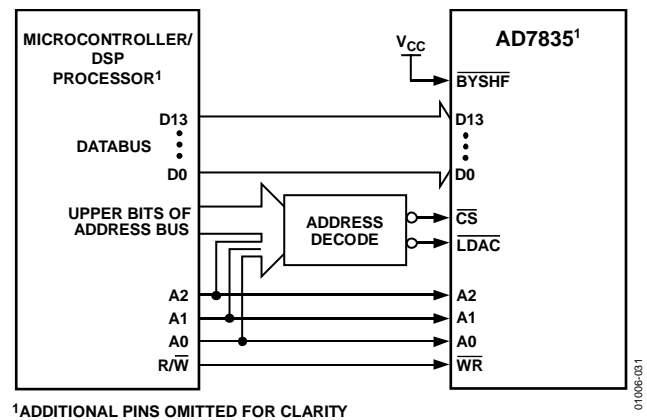

Figure 31. AD7835 16-Bit Interface

AD7834/AD7835

INTERFACING THE AD7835—8-BIT INTERFACE

Figure 32 shows an 8-bit interface between the AD7835 and a generic 8-bit microcontroller/DSP processor. Pin D13 to Pin D8 of the AD7835 are tied to DGND. Pin D7 to Pin D0 of the processor are connected to Pin D7 to Pin D0 of the AD7835. BYSHF is driven by the A0 line of the processor. This maps the DAC upper bits and lower bits into adjacent bytes in the processor address space. Table 14 shows the truth table for addressing the DACs in the AD7835. For example, if the base address for the DACs in the processor address space is decoded by the upper address bits to location HC000, then the upper and lower bits of the first DAC are at locations HC000 and HC001, respectively.

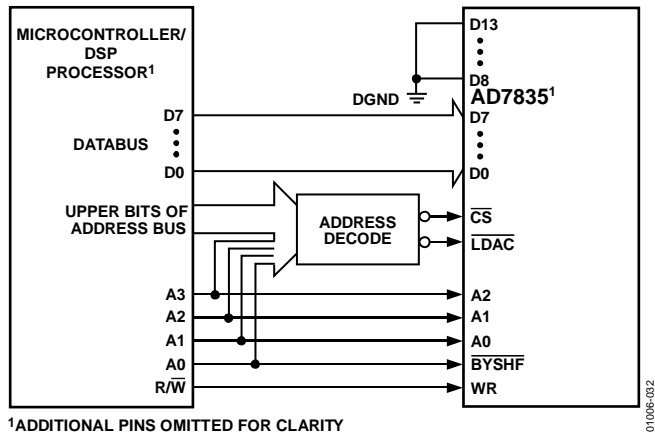

Figure 32. AD7835 8-Bit Interface

When writing to the DACs, the lower eight bits must be written first, followed by the upper six bits. The upper six bits should be output on data lines D0 to D5. Once again, the upper address lines of the processor are decoded to provide a \overline{CS} signal. They are also decoded in conjunction with lines A3 to A0 to provide an \overline{LDAC} signal. Alternatively, \overline{LDAC} can be driven by an external timing circuit or, if it is acceptable to allow the \overline{DAC} output to go to an intermediate value between 8-bit writes, \overline{LDAC} can be tied low.

Table 14. DAC Channel Decoding, 8-Bit Interface

Processor Address Lines				DAC Selected
A3	A2	A1	A0	
x	X	X	0	Upper 6 bits of all DACs
1	X	X	1	Lower 8 bits of all DACs
0	0	0	0	Upper 6 bits, DAC 1
0	0	0	1	Lower 8 bits, DAC 1
0	0	1	0	Upper 6 bits, DAC 2
0	0	1	1	Lower 8 bits, DAC 2
0	1	0	0	Upper 6 bits, DAC 3
0	1	0	1	Lower 8 bits, DAC 3
0	1	1	0	Upper 6 bits, DAC 4
0	1	1	1	Lower 8 bits, DAC 4

APPLICATIONS INFORMATION

SERIAL INTERFACE TO MULTIPLE AD7834S

Figure 33 shows how the package address pins of the AD7834 are used to address multiple AD7834s. This figure shows only 10 devices, but up to 32 AD7834s can each be assigned a unique address by hardwiring each of the package address pins to V_{CC} or DGND. Normal operation of the device occurs when \overline{PAEN} is low. When serial data is being written to the AD7834s, only the device with the same package address as the package address contained in the serial data accepts data into the input registers. Conversely, if \overline{PAEN} is high, the package address is ignored, and the data is loaded into the same channel on each package.

The primary limitation with multiple packages is the output update rate. For example, if an output update rate of 10 kHz is required, 100 μ s are available to load all DACs. Assuming a serial clock frequency of 10 MHz, it takes 2.5 μ s to load data to one DAC. Thus, 40 DACs or 10 packages can be updated in this time. As the update rate requirement decreases, the number of possible packages increases.

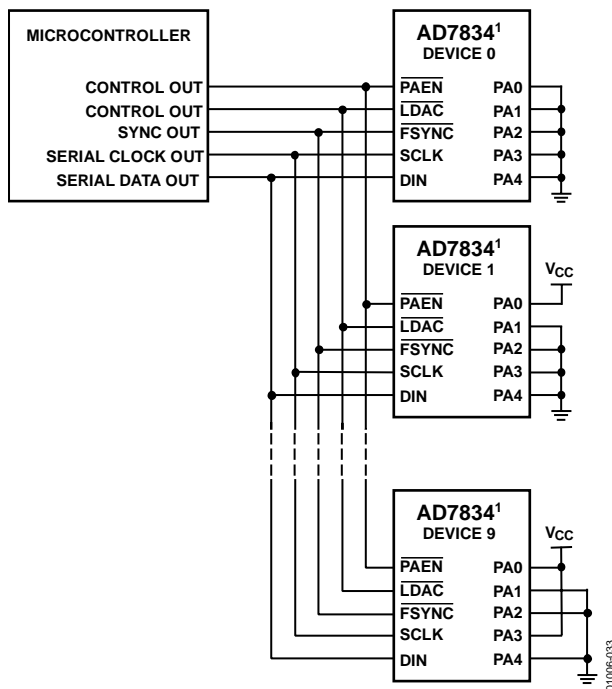

¹ADDITIONAL PINS OMITTED FOR CLARITY

Figure 33. Serial Interface to Multiple AD7834s

OPTO-ISOLATED INTERFACE

In many process control applications, it is necessary to provide an isolation barrier between the controller and the unit being controlled. Opto-isolators can provide voltage isolation in excess of 3 kV. The serial loading structure of the AD7834 makes it ideal for opto-isolated interfaces because the number of interface lines is kept to a minimum.

Figure 34 shows a 5-channel isolated interface to the AD7834. Multiple devices are connected to the outputs of the opto-coupler and controlled as for serial interfacing. To reduce the number of opto-isolators, the \overline{PAEN} line doesn't need to be controlled if it is not used. If the \overline{PAEN} line is not controlled by the microcontroller, it should be tied low at each device. If simultaneous updating of the DACs is not required, the LDAC pin on each part can be tied permanently low and another opto-isolator is not needed.

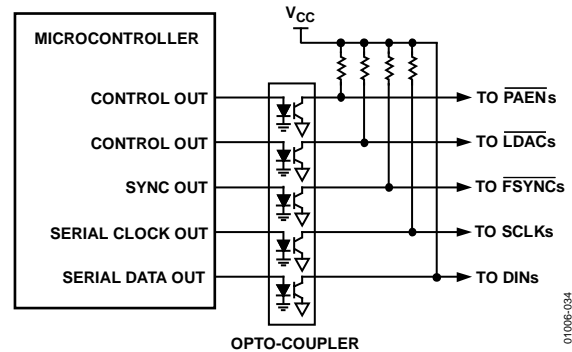

Figure 34. Opto-Isolated Interface

AUTOMATED TEST EQUIPMENT

The AD7834/AD7835 are particularly suited for use in an automated test environment. Figure 35 shows the AD7835 providing the necessary voltages for the pin driver and the window comparator in a typical ATE pin electronics configuration. Two AD588s are used to provide reference voltages for the AD7835. In the configuration shown, the AD588s are configured so that the voltage at Pin 1 is 5 V greater than the voltage at Pin 9 and the voltage at Pin 15 is 5 V less than the voltage at Pin 9.

One AD588 is used as a reference for DAC 1 and DAC 2. These DACs are used to provide high and low levels for the pin driver. The pin driver can have an associated offset. This can be nulled by applying an offset voltage to Pin 9 of the AD588. First, the code 1000 . . . 0000 is loaded into the DAC 1 latch, and the pin driver output is set to the DAC 1 output. The V_{OFFSET} voltage is adjusted until 0 V appears between the pin driver output and DUT GND. This causes both $V_{\text{REF}(+)A}$ and $V_{\text{REF}(-)A}$ to be offset with respect to AGND by an amount equal to V_{OFFSET} .

However, the output of the pin driver varies from -5 V to $+5$ V with respect to DUT GND as the DAC input code varies from 000 . . . 000 to 111 . . . 111. The V_{OFFSET} voltage is also applied to the DSGA pin. When a clear is performed on the AD7835, the output of the pin driver is 0 V with respect to DUT GND.

AD7834/AD7835

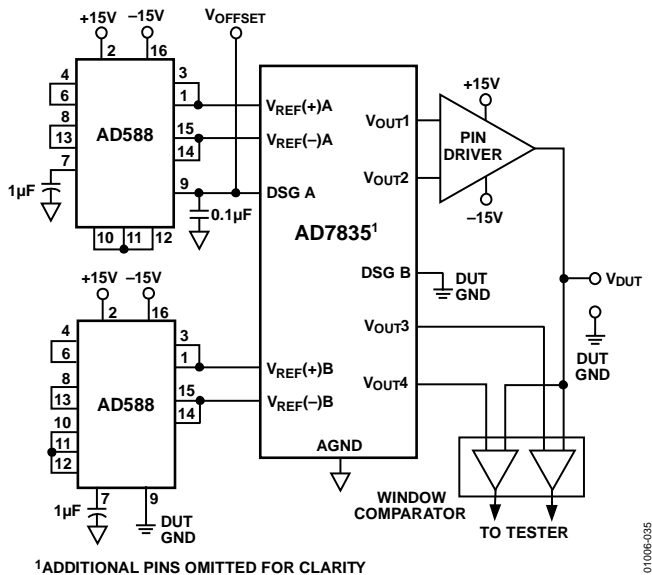

¹ADDITIONAL PINS OMITTED FOR CLARITY

Figure 35. ATE Application

The other AD588 provides a reference voltage for DAC 3 and DAC 4. These provide the reference voltages for the window comparator shown in Figure 35. Pin 9 of this AD588 is connected to DUT GND. This causes $V_{REF(+)}B$ and $V_{REF(-)}B$ to be referenced to DUT GND. As DAC 3 and DAC 4 input codes vary from 000 . . . 000 to 111 . . . 111, V_{OUT3} and V_{OUT4} vary from -5 V to $+5$ V with respect to DUT GND. DUT GND is also connected to DSG B. When the AD7835 is cleared, V_{OUT3} and V_{OUT4} are cleared to 0 V with respect to DUT GND.

Care must be taken to ensure that the maximum and minimum voltage specifications for the AD7835 reference voltages are followed as shown in Figure 35.

POWER SUPPLY BYPASSING AND GROUNDING

In any circuit where accuracy is important, careful consideration of the power supply and ground return layout helps to ensure the rated performance. The printed circuit boards on which the AD7834/AD7835 are mounted should be designed so the analog and digital sections are separated and confined to certain areas of the boards. This facilitates the use of ground planes that can be easily separated. A minimum etch technique is generally best for ground planes because it gives the best shielding. Digital and analog ground planes should be joined at only one place.

If the AD7834/AD7835 are the only devices requiring an AGND to DGND connection, then the ground planes should be connected at the AGND and DGND pins of the AD7834/AD7835. If the AD7834/AD7835 are in a system where multiple devices require an AGND to DGND connection, the connection can still be made at one point only, a star ground point, which can be established as close as possible to the AD7834/AD7835.

Digital lines running under the device must be avoided because they couple noise onto the die. The analog ground plane can run under the AD7834/AD7835 to avoid noise coupling. The power supply lines of the AD7834/AD7835 can use as large a trace as possible to provide low impedance paths and reduce the effects of glitches on the power supply line. Fast switching signals, such as clocks, should be shielded with digital ground to avoid radiating noise to other parts of the board. These signals should never be run near the analog inputs. Avoid crossover of digital and analog signals. Traces on opposite sides of the board should run at right angles to each other. This reduces the effects of feedthrough through the board. A microstrip method is best but not always possible with a double-sided board. With this method, the component side of the board is dedicated to ground plane while signal traces are placed on the solder side.

The AD7834/AD7835 must have ample supply bypassing located as close as possible to the package, ideally right up against the device. Figure 36 shows the recommended capacitor values of $10 \mu\text{F}$ in parallel with $0.1 \mu\text{F}$ on each of the supplies. The $10 \mu\text{F}$ capacitors are the tantalum bead type. The $0.1 \mu\text{F}$ capacitor can have low effective series resistance (ESR) and effective series inductance (ESI), such as the common ceramic types, which provide a low impedance path to ground at high frequencies to handle transient currents due to internal logic switching.

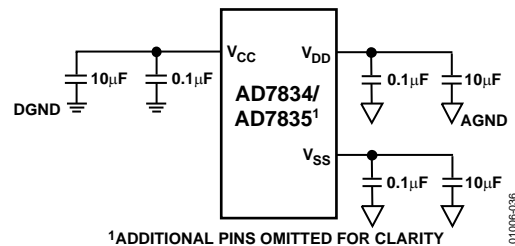

¹ADDITIONAL PINS OMITTED FOR CLARITY

Figure 36. Power Supply Decoupling

OUTLINE DIMENSIONS

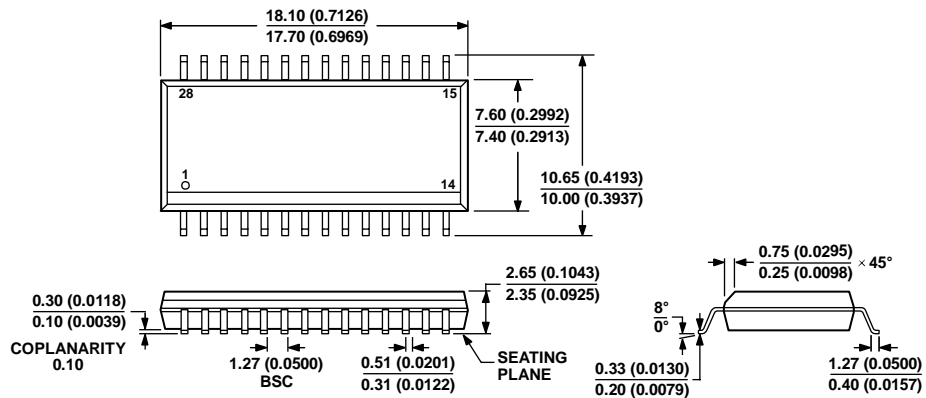

COMPLIANT TO JEDEC STANDARDS MS-013-AE
 CONTROLLING DIMENSIONS ARE IN MILLIMETERS; INCH DIMENSIONS
 (IN PARENTHESES) ARE ROUNDED-OFF MILLIMETER EQUIVALENTS FOR
 REFERENCE ONLY AND ARE NOT APPROPRIATE FOR USE IN DESIGN.

Figure 37. 28-Lead Standard Small Outline Package [SOIC_W]
 Wide Body
 (RW-28)
 Dimensions shown in millimeters and (inches)

060706-A

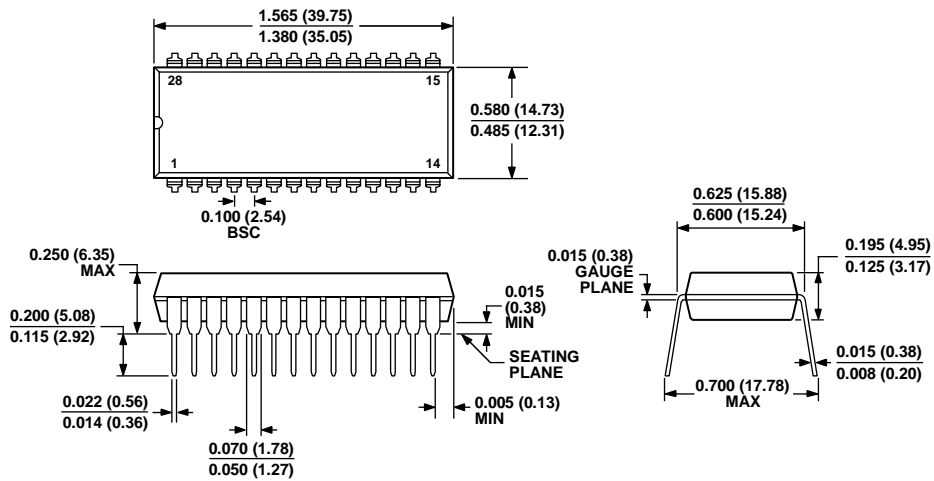

COMPLIANT TO JEDEC STANDARDS MS-011
 CONTROLLING DIMENSIONS ARE IN INCHES; MILLIMETER DIMENSIONS
 (IN PARENTHESES) ARE ROUNDED-OFF INCH EQUIVALENTS FOR
 REFERENCE ONLY AND ARE NOT APPROPRIATE FOR USE IN DESIGN.
 CORNER LEADS MAY BE CONFIGURED AS WHOLE LEADS.

Figure 38. 28-Lead Plastic Dual In-Line Package [PDIP]
 Wide Body
 (N-28-2)
 Dimensions shown in inches and (millimeters)

071006-A

AD7834/AD7835

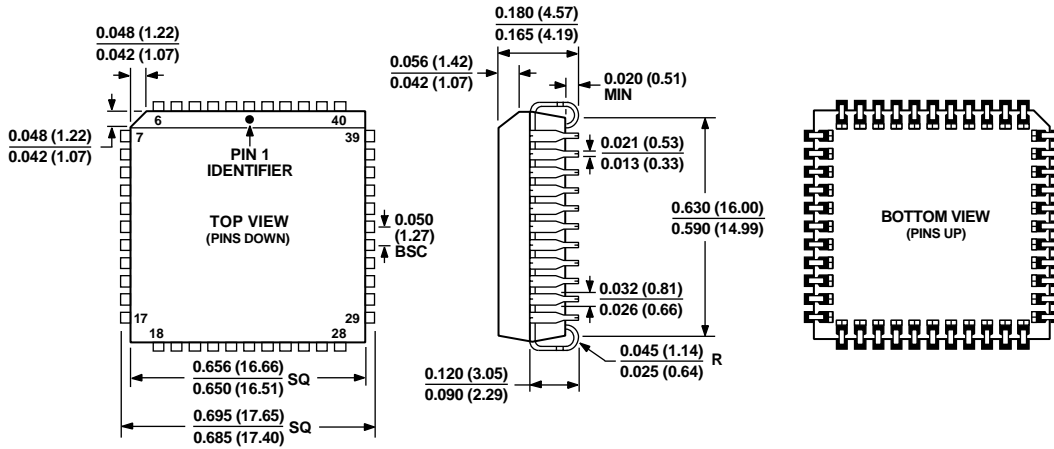

COMPLIANT TO JEDEC STANDARDS MO-047-AC
 CONTROLLING DIMENSIONS ARE IN INCHES; MILLIMETER DIMENSIONS
 (IN PARENTHESES) ARE ROUNDED-OFF INCH EQUIVALENTS FOR
 REFERENCE ONLY AND ARE NOT APPROPRIATE FOR USE IN DESIGN.

Figure 39. 44-Lead Plastic Leaded Chip Carrier [PLCC]
 (P-44A)

Dimensions shown in inches and (millimeters)

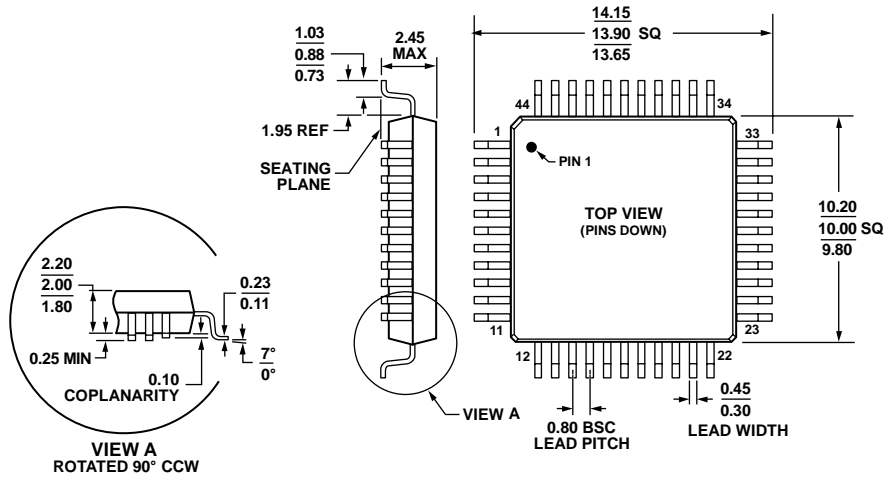

COMPLIANT TO JEDEC STANDARDS MO-112-AA-1
 Figure 40. 44-Lead Metric Quad Flat Package [MQFP]
 (S-44-2)

Dimensions show in millimeters

041807-A

ORDERING GUIDE

Model	Temperature Range	Linearity Error (LSBs)	DNL (LSBs)	Package Description	Package Option
AD7834AR	-40°C to +85°C	±2	±0.9	28-Lead SOIC_W	RW-28
AD7834AR-REEL	-40°C to +85°C	±2	±0.9	28-Lead SOIC_W	RW-28
AD7834ARZ ¹	-40°C to +85°C	±2	±0.9	28-Lead SOIC_W	RW-28
AD7834ARZ-REEL ¹	-40°C to +85°C	±2	±0.9	28-Lead SOIC_W	RW-28
AD7834BR	-40°C to +85°C	±1	±0.9	28-Lead SOIC_W	RW-28
AD7834BR-REEL	-40°C to +85°C	±1	±0.9	28-Lead SOIC_W	RW-28
AD7834BRZ ¹	-40°C to +85°C	±1	±0.9	28-Lead SOIC_W	RW-28
AD7834BRZ-REEL ¹	-40°C to +85°C	±1	±0.9	28-Lead SOIC_W	RW-28
AD7834AN	-40°C to +85°C	±2	±0.9	28-Lead PDIP	N-28-2
AD7834ANZ ¹	-40°C to +85°C	±2	±0.9	28-Lead PDIP	N-28-2
AD7834BN	-40°C to +85°C	±1	±0.9	28-Lead PDIP	N-28-2
AD7834BNZ ¹	-40°C to +85°C	±1	±0.9	28-Lead PDIP	N-28-2
AD7835AP	-40°C to +85°C	±2	±0.9	44-Lead PLCC	P-44A
AD7835AP-REEL	-40°C to +85°C	±2	±0.9	44-Lead PLCC	P-44A
AD7835APZ ¹	-40°C to +85°C	±2	±0.9	44-Lead PLCC	P-44A
AD7835APZ-REEL ¹	-40°C to +85°C	±2	±0.9	44-Lead PLCC	P-44A
AD7835AS	-40°C to +85°C	±2	±0.9	44-Lead-MQFP	S-44-2
AD7835AS-REEL	-40°C to +85°C	±2	±0.9	44-Lead-MQFP	S-44-2
AD7835ASZ ¹	-40°C to +85°C	±2	±0.9	44-Lead-MQFP	S-44-2
AD7835ASZ-REEL ¹	-40°C to +85°C	±2	±0.9	44-Lead-MQFP	S-44-2

¹ Z = RoHS Compliant Part.

NOTES

Looking for pricing, stock, or lifecycle information?

Click below to explore more details on WIN SOURCE:

 [View AD7834ANZ on WIN SOURCE](#)

 [Analog Devices Inc. Information](#)

Optimize Your Supply Chain with WIN SOURCE Solutions

-  Global Sourcing Solution
-  Obsolete Management
-  Cost Control Management
-  Shortage Management
-  Alternative Solution
-  Excess Inventory Management