



**THE DATASHEET OF
AD9846AJSTZ**



FEATURES

- 30 MSPS Correlated Double Sampler (CDS)**
- 4 dB \pm 6 dB 6-Bit Pixel Gain Amplifier (PxGA)[®]**
- 2 dB to 36 dB 10-Bit Variable Gain Amplifier (VGA)**
- Low Noise Clamp Circuits**
- Analog Preblanking Function**
- 10-Bit 30 MSPS A/D Converter**
- Auxiliary Inputs with VGA and Input Clamp**
- 3-Wire Serial Digital Interface**
- 3 V Single Supply Operation**
- Low Power: 100 mW @ 2.7 V**
- 48-Lead LQFP Package**

APPLICATIONS

- Digital Still Cameras**
- Digital Video Camcorders**
- Industrial Imaging**

PRODUCT DESCRIPTION

The AD9846A is a complete analog signal processor for CCD applications. It features a 30 MHz single-channel architecture designed to sample and condition the outputs of interlaced and progressive scan area CCD arrays. The AD9846A's signal chain consists of an input clamp, correlated double sampler (CDS), Pixel Gain Amplifier (PxGA), digitally controlled variable gain amplifier (VGA), black level clamp, and a 10-bit A/D converter. Additional input modes are provided for processing analog video signals.

The internal registers are programmed through a 3-wire serial digital interface. Programmable features include gain adjustment, black level adjustment, input configuration, and power-down modes.

The AD9846A operates from a single 3 V power supply, typically dissipates 117 mW, and is packaged in a 48-lead LQFP.

FUNCTIONAL BLOCK DIAGRAM

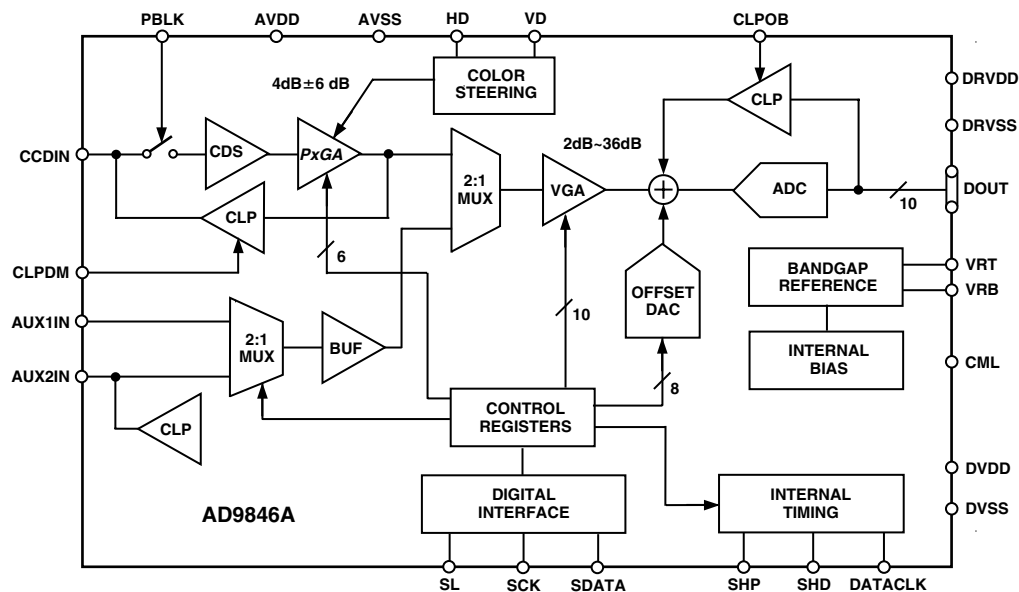

PxGA is a registered trademark of Analog Devices, Inc.

REV. 0

Information furnished by Analog Devices is believed to be accurate and reliable. However, no responsibility is assumed by Analog Devices for its use, nor for any infringements of patents or other rights of third parties that may result from its use. No license is granted by implication or otherwise under any patent or patent rights of Analog Devices.

One Technology Way, P.O. Box 9106, Norwood, MA 02062-9106, U.S.A.
 Tel: 781/329-4700
 Fax: 781/326-8703
www.analog.com
 © Analog Devices, Inc., 2001

AD9846A—SPECIFICATIONS

GENERAL SPECIFICATIONS (T_{MIN} to T_{MAX}, AVDD = DVDD = 3.0 V, f_{DATACLK} = 30 MHz, unless otherwise noted.)

Parameter	Min	Typ	Max	Unit
TEMPERATURE RANGE				
Operating	-20		+85	°C
Storage	-65		+150	°C
POWER SUPPLY VOLTAGE				
Analog, Digital, Digital Driver	2.7		3.6	V
POWER CONSUMPTION	(Specified Under Each Mode of Operation)			
Normal Operation				
Power-Down Modes				
Fast Recovery Mode		85		mW
Standby		5		mW
Total Power-Down		1		mW
MAXIMUM CLOCK RATE	30			MHz
A/D CONVERTER				
Resolution	10			Bits
Differential Nonlinearity (DNL)		±0.5	±1.0	LSB
No Missing Codes	10			Bits Guaranteed
Full-Scale Input Voltage		2.0		V
Data Output Coding		Straight Binary		
VOLTAGE REFERENCE				
Reference Top Voltage (VRT)		2.0		V
Reference Bottom Voltage (VRB)		1.0		V

Specifications subject to change without notice.

DIGITAL SPECIFICATIONS (DRVDD = 2.7 V, C_L = 20 pF unless otherwise noted.)

Parameter	Symbol	Min	Typ	Max	Unit
LOGIC INPUTS					
High Level Input Voltage	V _{IH}	2.1			V
Low Level Input Voltage	V _{IL}			0.6	V
High Level Input Current	I _{IH}		10		μA
Low Level Input Current	I _{IL}		10		μA
Input Capacitance	C _{IN}		10		pF
LOGIC OUTPUTS					
High Level Output Voltage, I _{OH} = 2 mA	V _{OH}	2.2			V
Low Level Output Voltage, I _{OL} = 2 mA	V _{OL}			0.5	V

Specifications subject to change without notice.

CCD-MODE SPECIFICATIONS (T_{MIN} to T_{MAX} , $AV_{\text{DD}} = DV_{\text{DD}} = 3.0 \text{ V}$, $f_{\text{DATACLK}} = f_{\text{SHP}} = f_{\text{SHD}} = 30 \text{ MHz}$, unless otherwise noted.)

Parameter	Min	Typ	Max	Unit	Note
POWER CONSUMPTION		117		mW	See TPC 1 for Power Curves
MAXIMUM CLOCK RATE	30			MHz	
CDS					
Gain		0		dB	
Allowable CCD Reset Transient ¹		500		mV	See Input Waveform in Footnote 1
Max Input Range Before Saturation ¹	1.0			V p-p	$PxGA$ Gain at 4 dB
Max CCD Black Pixel Amplitude ¹		200		mV	
PIXEL GAIN AMPLIFIER ($PxGA$)					
Max Input Range	1.0			V p-p	
Max Output Range	1.6			V p-p	
Gain Control Resolution		64		Steps	
Gain Monotonicity		Guaranteed			
Gain Range (Two's Complement Coding)					See Figure 28 for $PxGA$ Gain Curve
Min Gain ($PxGA$ Gain Code 32)		-2		dB	
Max Gain ($PxGA$ Gain Code 31)		10		dB	
VARIABLE GAIN AMPLIFIER (VGA)					
Max Input Range	1.6			V p-p	
Max Output Range	2.0			V p-p	
Gain Control Resolution		1024		Steps	
Gain Monotonicity		Guaranteed			
Gain Range					See Figure 29 for VGA Gain Curve
Low Gain (VGA Gain Code 91)		2		dB	
Max Gain (VGA Gain Code 1023)		36		dB	
BLACK LEVEL CLAMP					
Clamp Level Resolution		256		Steps	
Clamp Level					Measured at ADC Output
Min Clamp Level		0		LSB	
Max Clamp Level		63.75		LSB	
SYSTEM PERFORMANCE					
Gain Accuracy (VGA Code 91 to 1023) ²	-0.5		+0.5		Specifications Include Entire Signal Chain Use Equations on Page 18 to Calculate Gain
$PxGA$ Gain Accuracy					
Min Gain ($PxGA$ Register Code 32)	-1	0	+1	dB	VGA Gain Fixed at 2 dB (Code 91)
Max Gain ($PxGA$ Code 31)	11	12	12	dB	VGA Gain Fixed at 2 dB (Code 91)
Peak Nonlinearity, 500 mV Input Signal		0.1		%	12 dB Gain Applied
Total Output Noise		0.2		LSB rms	AC Grounded Input, 6 dB Gain Applied
Power Supply Rejection (PSR)		40		dB	Measured with Step Change on Supply
POWER-UP RECOVERY TIME					
Fast Recovery Mode		0.1		ms	Normal Clock Signals Applied
Reference Standby Mode		1		ms	
Total Power-Down Mode		3		ms	
Power-Off Condition		15		ms	

NOTES

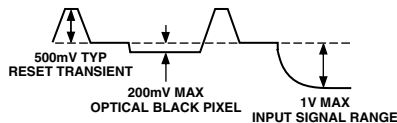
¹Input Signal Characteristics defined as follows:

² $PxGA$ gain fixed at 4 dB (Code 63).

Specifications subject to change without notice.

AD9846A—SPECIFICATIONS

AUX1-MODE SPECIFICATIONS (T_{MIN} to T_{MAX} , $AVDD = DVDD = 3.0\text{ V}$, $f_{DATACLK} = 30\text{ MHz}$, unless otherwise noted.)

Parameter	Min	Typ	Max	Unit
POWER CONSUMPTION		82		mW
MAXIMUM CLOCK RATE	30			MHz
INPUT BUFFER				
Gain		0		dB
Max Input Range	1.0			V p-p
VGA				
Max Output Range	2.0			V p-p
Gain Control Resolution		1023		Steps
Gain (Selected Using VGA Gain Register)				
Min Gain		0		dB
Max Gain		36		dB

Specifications subject to change without notice.

AUX2-MODE SPECIFICATIONS (T_{MIN} to T_{MAX} , $AVDD = DVDD = 3.0\text{ V}$, $f_{DATACLK} = 30\text{ MHz}$, unless otherwise noted.)

Parameter	Min	Typ	Max	Unit
POWER CONSUMPTION		86		mW
MAXIMUM CLOCK RATE	30			MHz
INPUT BUFFER	(Same as AUX1-MODE)			
VGA				
Max Output Range	2.0			V p-p
Gain Control Resolution		512		Steps
Gain (Selected Using VGA Gain Register)				
Min Gain		0		dB
Max Gain		18		dB
ACTIVE CLAMP				
Clamp Level Resolution		256		Steps
Clamp Level (Measured at ADC Output)				
Min Clamp Level		0		LSB
Max Clamp Level		63.75		LSB

Specifications subject to change without notice.

TIMING SPECIFICATIONS ($C_L = 20$ pF, $f_{SAMP} = 30$ MHz, CCD-Mode Timing in Figures 5 and 6, AUX-Mode Timing in Figure 7. Serial Timing in Figures 21–24.)

Parameter	Symbol	Min	Typ	Max	Unit
SAMPLE CLOCKS					
DATACLK, SHP, SHD Clock Period	t_{CONV}	32	33		ns
DATACLK Hi/Low Pulsewidth	t_{ADC}	13	16.7		ns
SHP Pulsewidth	t_{SHP}	5	8.3		ns
SHD Pulsewidth	t_{SHD}	5	8.3		ns
CLPDM Pulsewidth	t_{CDM}	4	10		Pixels
CLPOB Pulsewidth ¹	t_{COB}	2	20		Pixels
SHP Rising Edge to SHD Falling Edge	t_{S1}	0	8.3		ns
SHP Rising Edge to SHD Rising Edge	t_{S2}	13	16.7		ns
Internal Clock Delay	t_{ID}		3.0		ns
Inhibited Clock Period	t_{INH}	10			ns
DATA OUTPUTS					
Output Delay	t_{OD}		14.5	16	ns
Output Hold Time	t_H	7.0	7.6		ns
Pipeline Delay			9		Cycles
SERIAL INTERFACE					
Maximum SCK Frequency	f_{SCLK}	10			MHz
SL to SCK Setup Time	t_{LS}	10			ns
SCK to SL Hold Time	t_{LH}	10			ns
SDATA Valid to SCK Rising Edge Setup	t_{DS}	10			ns
SCK Falling Edge to SDATA Valid Hold	t_{DH}	10			ns
SCK Falling Edge to SDATA Valid Read	t_{DV}	10			ns

NOTES

¹Minimum CLPOB pulsewidth is for functional operation only. Wider typical pulses are recommended to achieve low noise clamp performance.

Specifications subject to change without notice.

ABSOLUTE MAXIMUM RATINGS

Parameter	With Respect To			Unit
		Min	Max	
AVDD1, AVDD2	AVSS	-0.3	+3.9	V
DVDD1, DVDD2	DVSS	-0.3	+3.9	V
DRVDD	DRVSS	-0.3	+3.9	V
Digital Outputs	DRVSS	-0.3	DRVDD + 0.3	V
SHP, SHD, DATACLK	DVSS	-0.3	DVDD + 0.3	V
CLPOB, CLPDM, PBLK	DVSS	-0.3	DVDD + 0.3	V
SCK, SL, SDATA	DVSS	-0.3	DVDD + 0.3	V
VRT, VRB, CMLEVEL	AVSS	-0.3	AVDD + 0.3	V
BYP1-4, CCDIN	AVSS	-0.3	AVDD + 0.3	V
Junction Temperature			150	°C
Lead Temperature (10 sec)			300	°C

ORDERING GUIDE

Model	Temperature Range	Package Description	Package Option
AD9846AJST	-20°C to +85°C	Thin Plastic Quad Flatpack (LQFP)	ST-48

THERMAL CHARACTERISTICS

Thermal Resistance

48-Lead LQFP Package

$$\theta_{JA} = 92^{\circ}\text{C}$$

CAUTION

ESD (electrostatic discharge) sensitive device. Electrostatic charges as high as 4000 V readily accumulate on the human body and test equipment and can discharge without detection. Although the AD9846A features proprietary ESD protection circuitry, permanent damage may occur on devices subjected to high-energy electrostatic discharges. Therefore, proper ESD precautions are recommended to avoid performance degradation or loss of functionality.



AD9846A

PIN CONFIGURATIONS

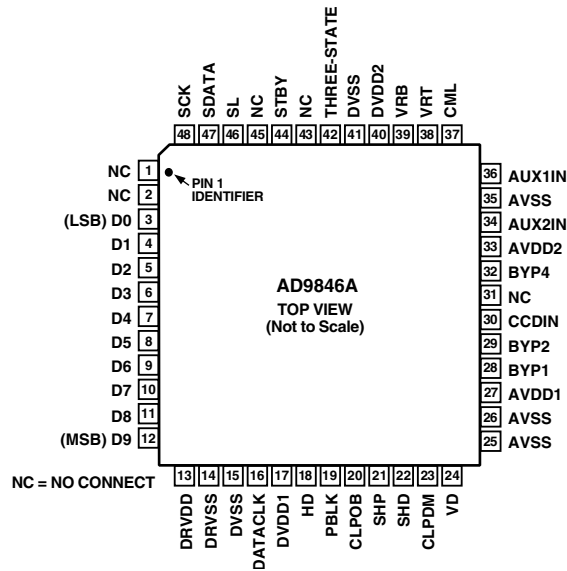

PIN FUNCTION DESCRIPTIONS

Pin Number	Name	Type	Description
1, 2	NC		Internally not Connected
3–12	D0–D9	DO	Digital Data Outputs
13	DRVDD	P	Digital Output Driver Supply
14	DRVSS	P	Digital Output Driver Ground
15, 41	DVSS	P	Digital Ground
16	DATACLK	DI	Digital Data Output Latch Clock
17	DVDD1	P	Digital Supply
18	HD	DI	Horizontal Drive. Used with VD for Color Steering Control
19	PBLK	DI	Preblanking Clock Input
20	CLPOB	DI	Black Level Clamp Clock Input
21	SHP	DI	CDS Sampling Clock for CCD's Reference Level
22	SHD	DI	CDS Sampling Clock for CCD's Data Level
23	CLPDM	DI	Input Clamp Clock Input
24	VD	DI	Vertical Drive. Used with HD for Color Steering Control
25, 26, 35	AVSS	P	Analog Ground
27	AVDD1	P	Analog Supply
28	BYP1	AO	Internal Bias Level Decoupling
29	BYP2	AO	Internal Bias Level Decoupling
30	CCDIN	AI	Analog Input for CCD Signal
31	NC	NC	Internally Not Connected
32	BYP4	AO	Internal Bias Level Decoupling
33	AVDD2	P	Analog Supply
34	AUX2IN	AI	Analog Input
36	AUX1IN	AI	Analog Input
37	CML	AO	Internal Bias Level Decoupling
38	VRT	AO	A/D Converter Top Reference Voltage Decoupling
39	VRB	AO	A/D Converter Bottom Reference Voltage Decoupling
40	DVDD2	P	Digital Supply
42	THREE-STATE	DI	Digital Output Disable. Active High
43	NC	NC	May be tied high or low. Do not leave floating.
44	STBY	DI	Standby Mode, Active High. Same as Serial Interface
45	NC	NC	Internally Not Connected. May be Tied High or Low
46	SL	DI	Serial Digital Interface Load Pulse
47	SDATA	DI	Serial Digital Interface Data
48	SCK	DI	Serial Digital Interface Clock

TYPE: AI = Analog Input, AO = Analog Output, DI = Digital Input, DO = Digital Output, P = Power.

DEFINITIONS OF SPECIFICATIONS

DIFFERENTIAL NONLINEARITY (DNL)

An ideal ADC exhibits code transitions that are exactly 1 LSB apart. DNL is the deviation from this ideal value. Thus every code must have a finite width. No missing codes guaranteed to 10-bit resolution indicates that all 1024 codes, respectively, must be present over all operating conditions.

PEAK NONLINEARITY

Peak nonlinearity, a full signal chain specification, refers to the peak deviation of the output of the AD9846A from a true straight line. The point used as “zero scale” occurs 1/2 LSB before the first code transition. “Positive full scale” is defined as a Level 1, 1/2 LSB beyond the last code transition. The deviation is measured from the middle of each particular output code to the true straight line. The error is then expressed as a percentage of the 2 V ADC full-scale signal. The input signal is always appropriately gained up to fill the ADC’s full-scale range.

TOTAL OUTPUT NOISE

The rms output noise is measured using histogram techniques. The standard deviation of the ADC output codes is calculated

in LSB, and represents the rms noise level of the total signal chain at the specified gain setting. The output noise can be converted to an equivalent voltage, using the relationship $1 \text{ LSB} = (\text{ADC Full Scale}/2^N \text{ codes})$ when N is the bit resolution of the ADC. For the AD9846A, 1 LSB is 2 mV.

POWER SUPPLY REJECTION (PSR)

The PSR is measured with a step change applied to the supply pins. This represents a very high frequency disturbance on the AD9846A’s power supply. The PSR specification is calculated from the change in the data outputs for a given step change in the supply voltage.

INTERNAL DELAY FOR SHP/SHD

The internal delay (also called aperture delay) is the time delay that occurs from when a sampling edge is applied to the AD9846A until the actual sample of the input signal is held. Both SHP and SHD sample the input signal during the transition from low to high, so the internal delay is measured from each clock’s rising edge to the instant the actual internal sample is taken.

EQUIVALENT INPUT CIRCUITS

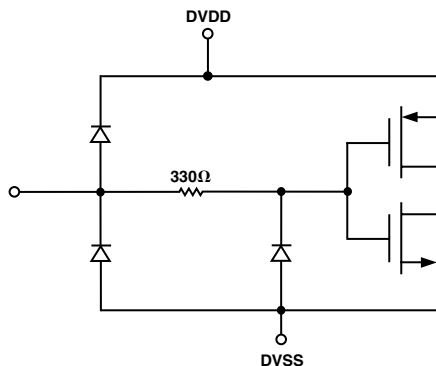

Figure 1. Digital Inputs—SHP, SHD, DATACLK, CLPOB, CLPDM, HD, VD, PBLK, SCK, SL

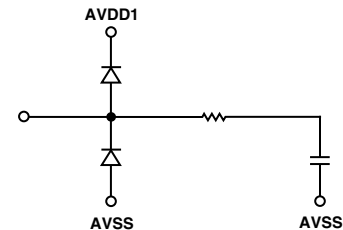

Figure 3. CCDIN (Pin 30)

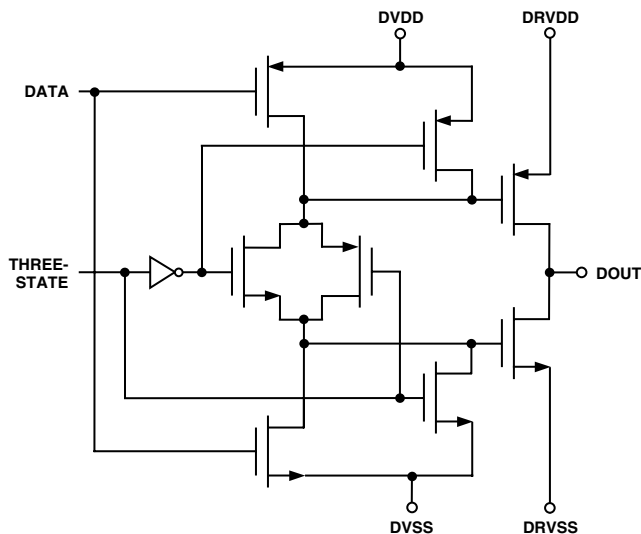

Figure 2. Data Outputs—D0–D9

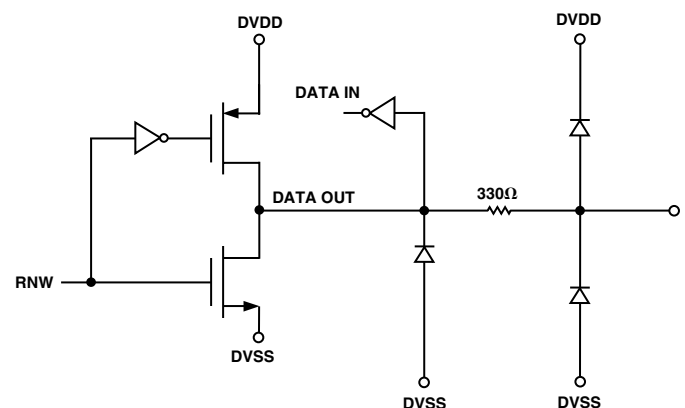
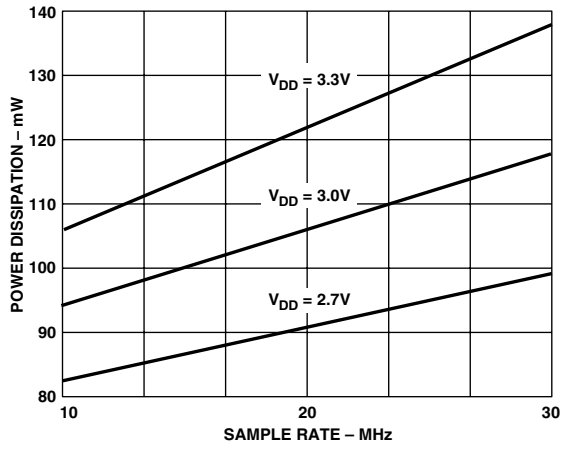
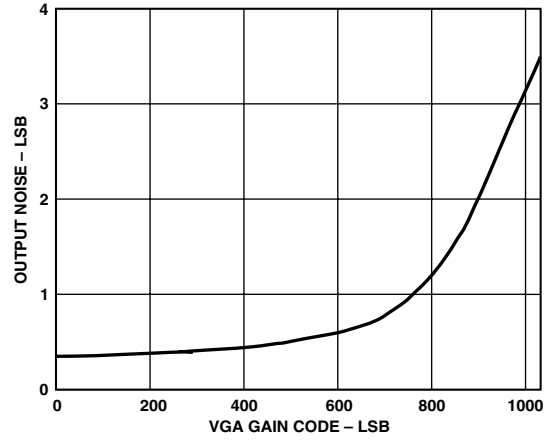

Figure 4. SDATA (Pin 47)

AD9846A—Typical Performance Characteristics



TPC 1. Power vs. Sample Rate



TPC 3. Output Noise vs. VGA Gain

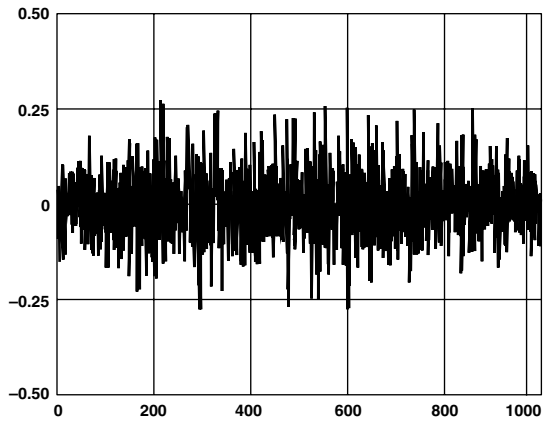

TPC 2. Typical DNL Performance

CCD-MODE AND AUX MODE TIMING

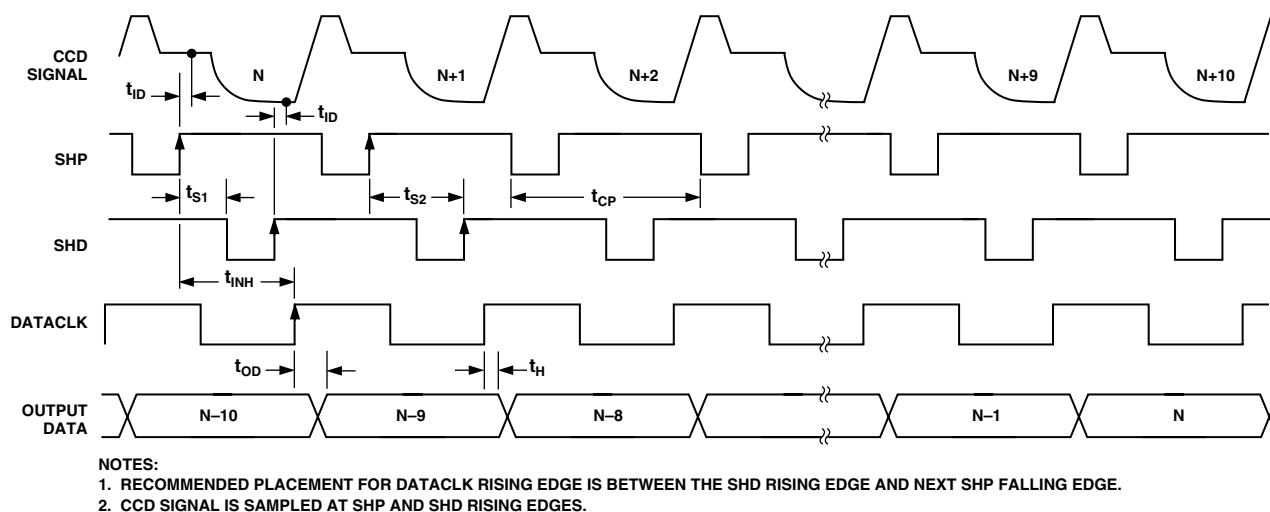

Figure 5. CCD-Mode Timing

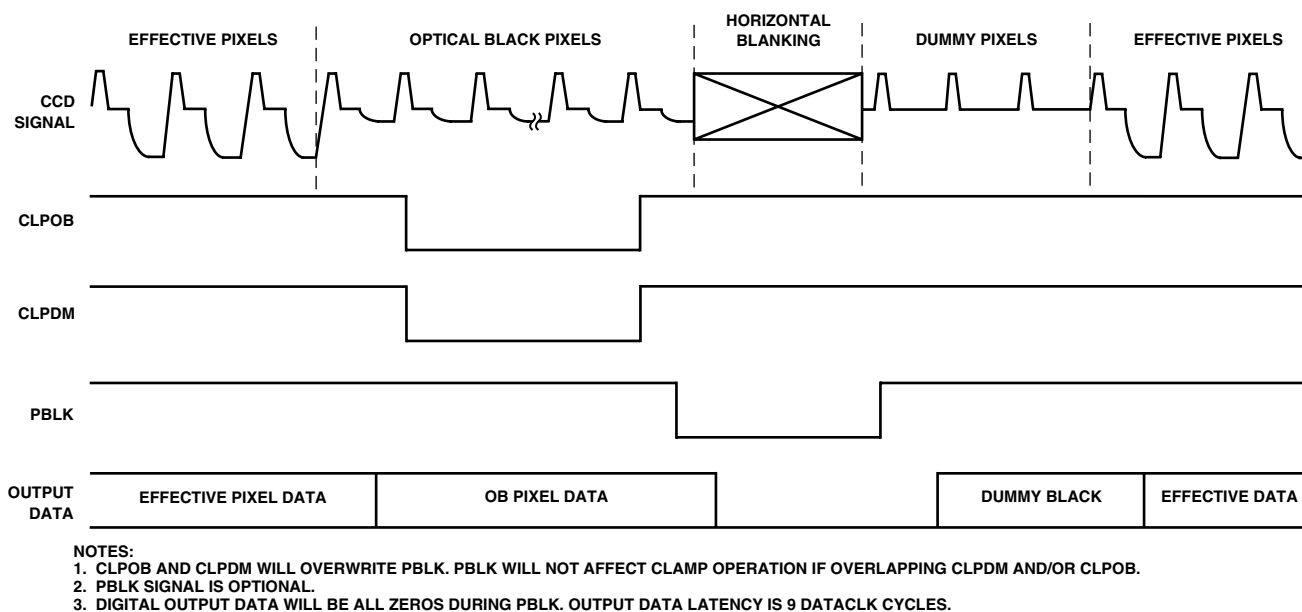

Figure 6. Typical CCD-Mode Line Clamp Timing

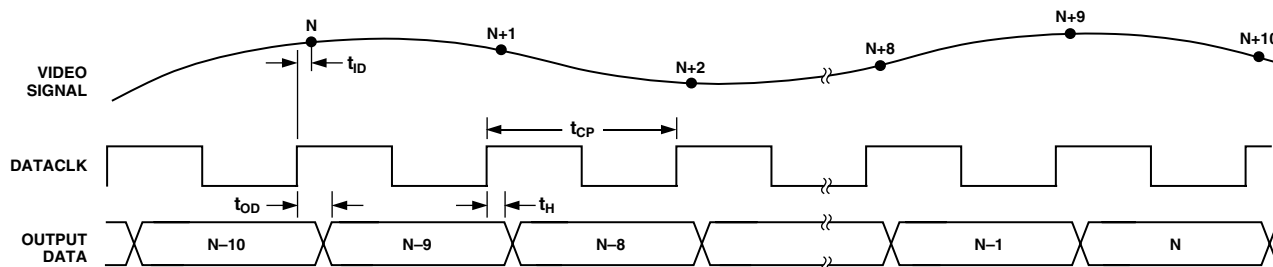

Figure 7. AUX-Mode Timing

AD9846A

PIXEL GAIN AMPLIFIER (PxGA) TIMING

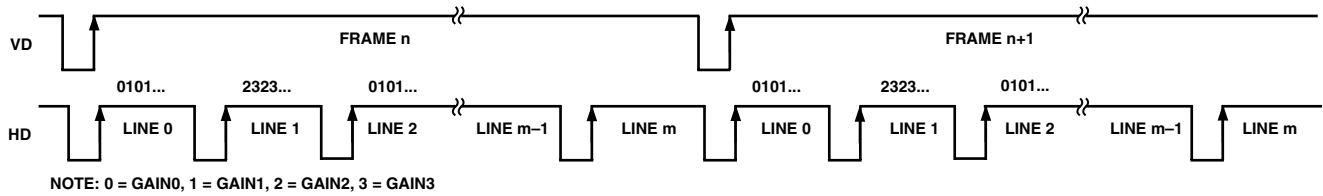
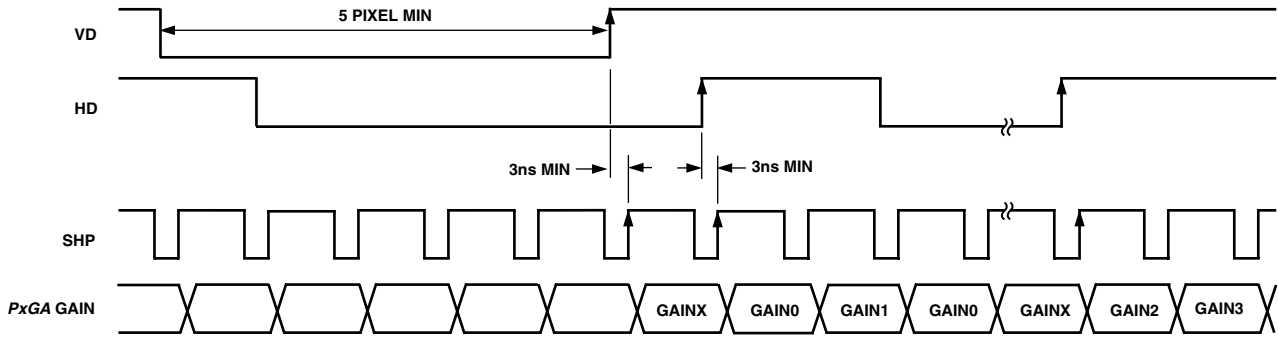

Figure 8. PxGA Mode 1 (Mosaic Separate) Frame/Line Gain Register Sequence



- NOTES:
1. MINIMUM PULSEWIDTH FOR HD AND VD IS 5 PIXEL CYCLES.
 2. BOTH VD AND HD ARE INTERNALLY UPDATED AT SHP RISING EDGES. MINIMUM SET-UP TIME IS 3ns.
 3. EVERY HD RISING EDGE WITH A PREVIOUS VD RISING EDGE WILL RESET TO 0101.
 4. EVERY HD RISING EDGE WITHOUT A PREVIOUS VD RISING EDGE WILL ALTERNATE BETWEEN 0101... AND 2323.

Figure 9. PxGA Mode 1 (Mosaic Separate) Detailed Timing

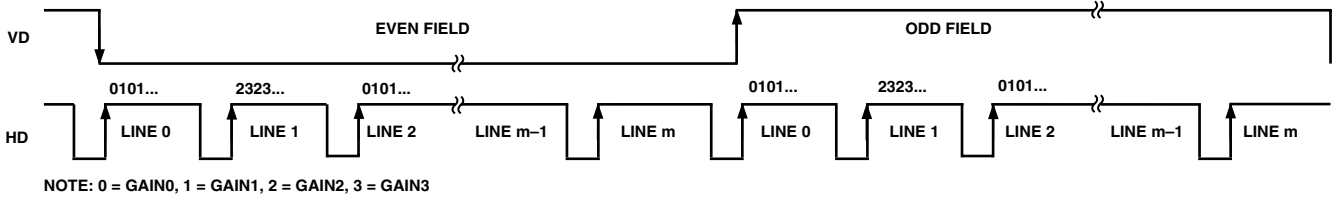
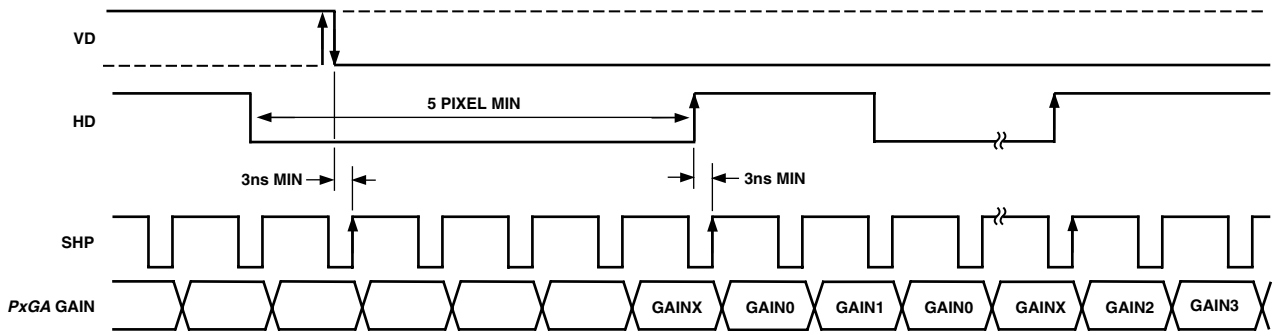

Figure 10. PxGA Mode 2 (Interlace) Frame/Line Gain Register Sequence



- NOTES:
1. BOTH VD AND HD ARE INTERNALLY UPDATED AT SHP RISING EDGES.
 2. EVERY HD RISING EDGE WITH A PREVIOUS VD RISING OR FALLING EDGE WILL RESET TO 0101.
 3. EVERY HD RISING EDGE WITHOUT A PREVIOUS VD RISING EDGE WILL ALTERNATE BETWEEN 0101... AND 2323.

Figure 11. PxGA Mode 2 (Interlace) Detailed Timing

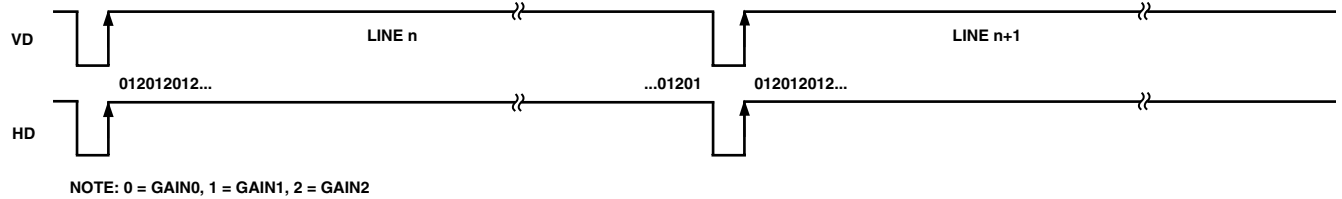

Figure 12. PxGA Mode 3 (3-Color) Frame/Line Gain Register Sequence

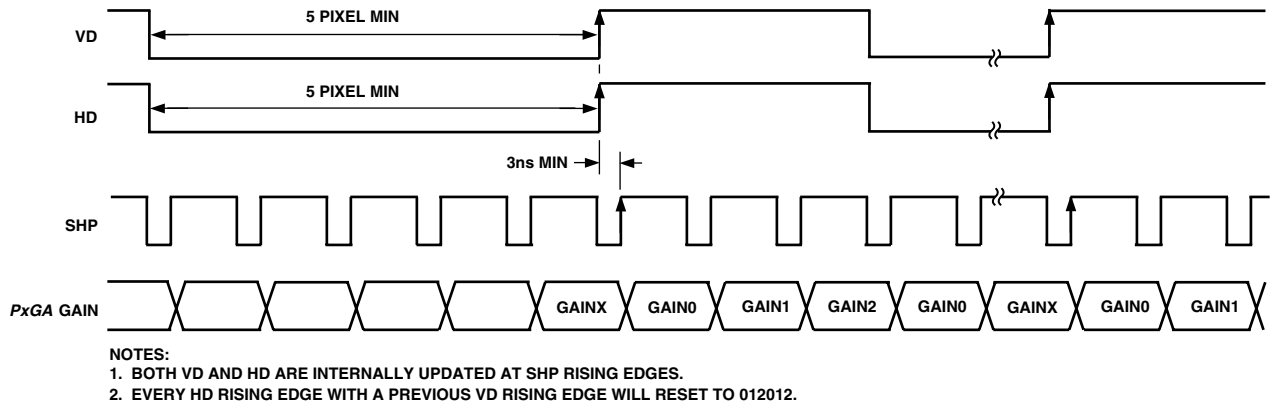

Figure 13. PxGA Mode 3 (3-Color) Detailed Timing

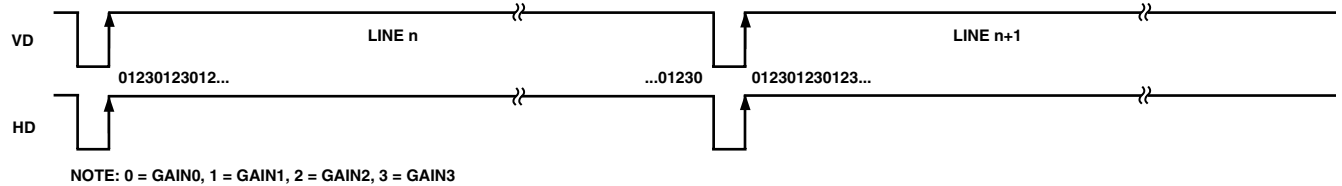

Figure 14. PxGA Mode 4 (4-Color) Frame/Line Gain Register Sequence

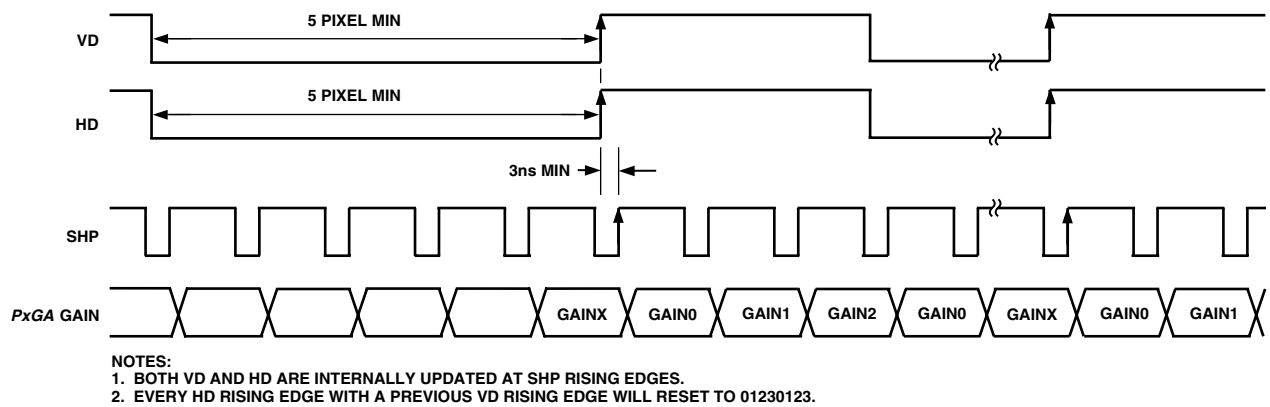
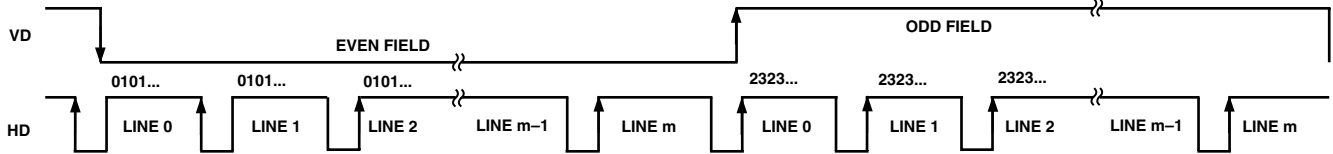

Figure 15. PxGA Mode 4 (4-Color) Detailed Timing

AD9846A



NOTE: 0 = GAIN0, 1 = GAIN1, 2 = GAIN2, 3 = GAIN3

Figure 16. PxGA Mode 5 (VD Selected) Frame/Line Gain Register Sequence

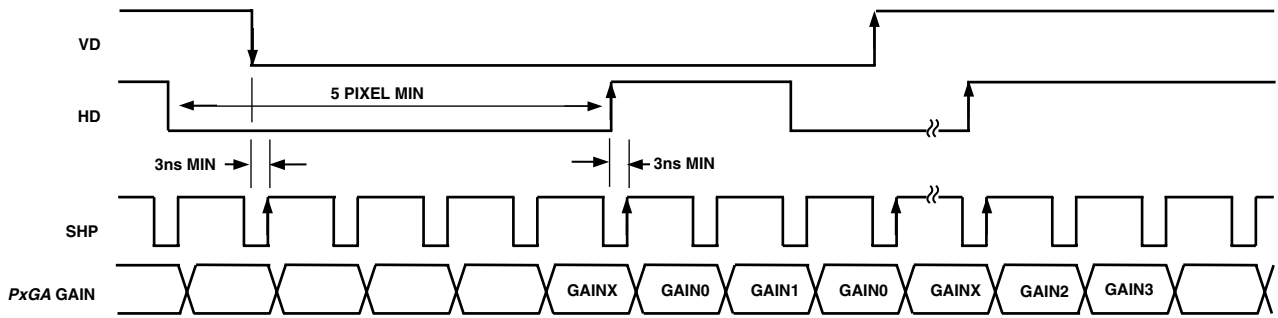

- NOTES:
1. BOTH VD AND HD ARE INTERNALLY UPDATED AT SHP RISING EDGES.
 2. EVERY HD RISING EDGE WITH A PREVIOUS VD FALLING EDGE WILL RESET TO 0101.
 3. EVERY HD RISING EDGE WITH A PREVIOUS VD RISING EDGE WILL RESET TO 2323.
 4. EVERY HD RISING EDGE WITHOUT A PREVIOUS VD RISING EDGE WILL REPEAT EITHER 0101... (EVEN) OR 2323... (ODD).

Figure 17. PxGA Mode 5 (VD Selected) Detailed Timing

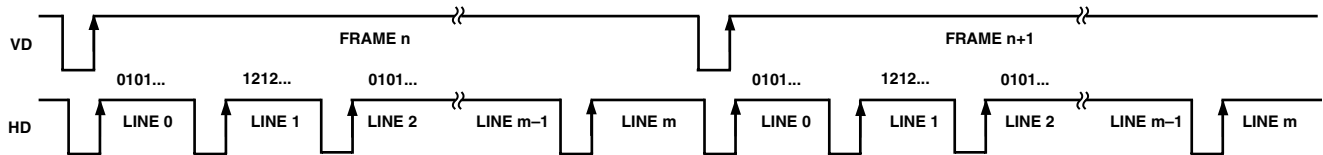

NOTE: 0 = GAIN0, 1 = GAIN1, 2 = GAIN2

Figure 18. PxGA Mode 6 (Mosaic Repeat) Frame/Line Gain Register Sequence

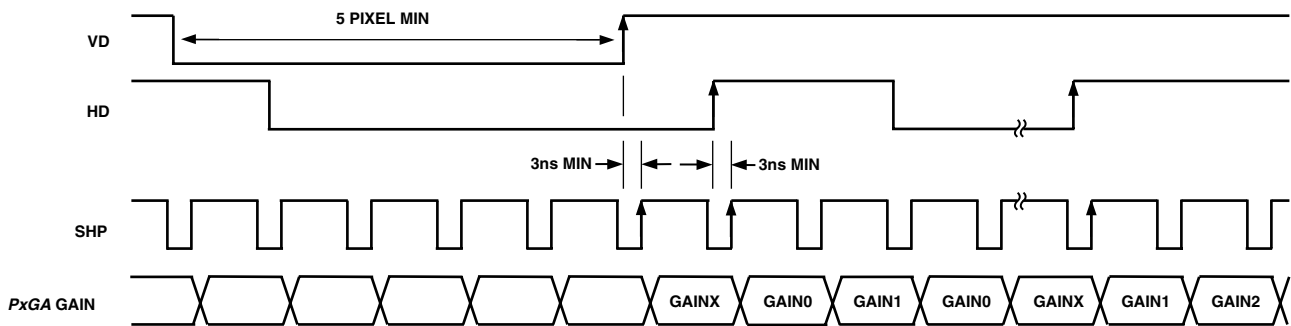

- NOTES:
1. MINIMUM PULSEWIDTH FOR HD AND VD IS 5 PIXEL CYCLES.
 2. BOTH VD AND HD ARE INTERNALLY UPDATED AT SHP RISING EDGES. MINIMUM SET-UP TIME IS 3ns.
 3. EVERY HD RISING EDGE WITH A PREVIOUS VD RISING EDGE WILL RESET TO 0101.
 4. EVERY HD RISING EDGE WITHOUT A PREVIOUS VD RISING EDGE WILL ALTERNATE BETWEEN 0101... AND 1212.

Figure 19. PxGA Mode 6 (Mosaic Repeat) Detailed Timing

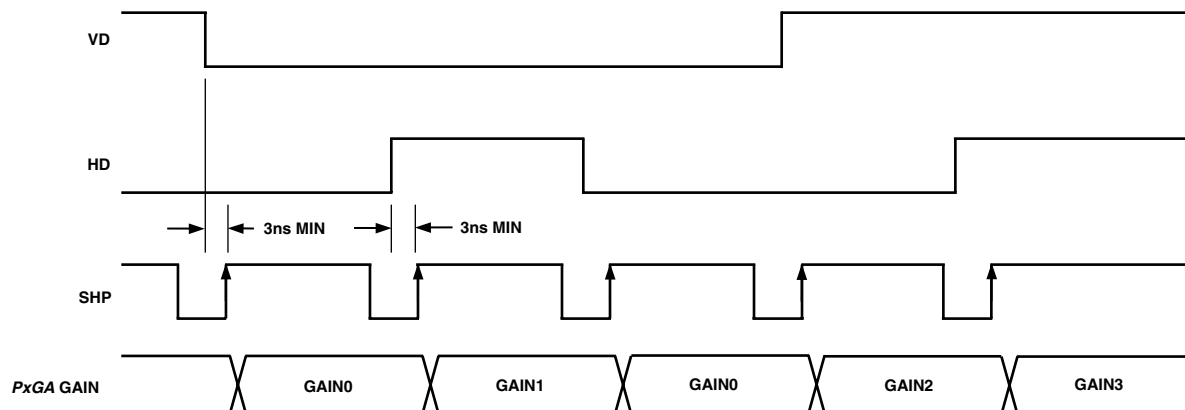

NOTES:

1. BOTH VD AND HD ARE INTERNALLY UPDATED AT SHP RISING EDGES.
2. VD = 0 AND HD = 0 SELECTS GAIN0.
3. VD = 0 AND HD = 1 SELECTS GAIN1.
4. VD = 1 AND HD = 0 SELECTS GAIN2.
5. VD = 1 AND HD = 1 SELECTS GAIN3.

Figure 20. PxGA Mode 7 (User-Specified) Detailed Timing

AD9846A

SERIAL INTERFACE TIMING AND INTERNAL REGISTER DESCRIPTION

Table I. Internal Register Map

Register Name	Address			Data Bits										
	A0	A1	A2	D0	D1	D2	D3	D4	D5	D6	D7	D8	D9	D10
Operation	0	0	0	Channel Select CCD/AUX1/2		Power-Down Modes		Software Reset	OB Clamp On/Off	0*	1**	0*	0*	0*
VGA Gain	1	0	0	LSB									MSB	X
Clamp Level	0	1	0	LSB							MSB	X	X	X
Control	1	1	0	Color Steering Mode Selection			P_xGA On/Off	Clock Polarity Select for SHP/SHD/CLP/DATA			0*	0*	Three- State	X
P_xGA Gain0	0	0	1	LSB					MSB	X	X	X	X	X
P_xGA Gain1	1	0	1	LSB					MSB	X	X	X	X	X
P_xGA Gain2	0	1	1	LSB					MSB	X	X	X	X	X
P_xGA Gain3	1	1	1	LSB					MSB	X	X	X	X	X

*Internal use only. Must be set to zero.

**Must be set to one.

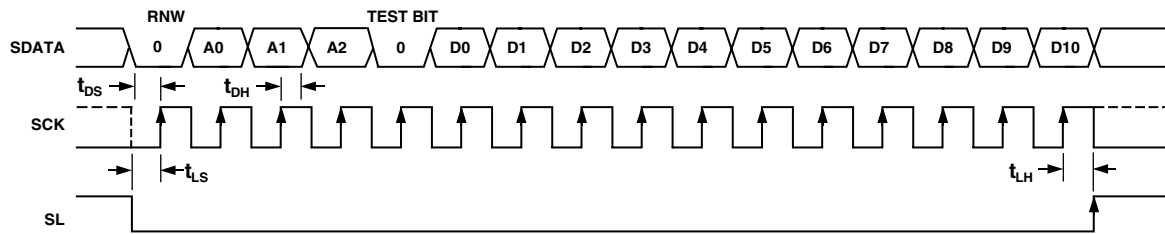

- NOTES:
1. SDATA BITS ARE INTERNALLY LATCHED ON THE RISING EDGES OF SCK.
 2. RNW = READ-NOT WRITE. SET LOW FOR WRITE OPERATION.
 3. TEST BITS = INTERNAL USE ONLY. MUST BE SET LOW.
 4. SYSTEM UPDATE OF LOADED REGISTERS OCCURS ON SL RISING EDGE.

Figure 21. Serial Write Operation

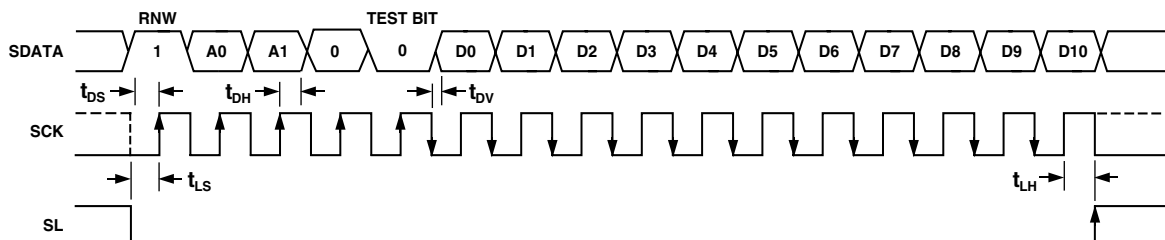

- NOTES:
1. RNW = READ-NOT WRITE. SET HIGH FOR READ OPERATION.
 2. TEST BITS = INTERNAL USE ONLY. MUST BE SET LOW.
 3. SERIAL DATA FROM THE SELECTED REGISTER IS VALID STARTING AFTER THE FIFTH SCK FALLING EDGE, AND IS UPDATED ON SCK FALLING EDGES.

Figure 22. Serial Readback Operation

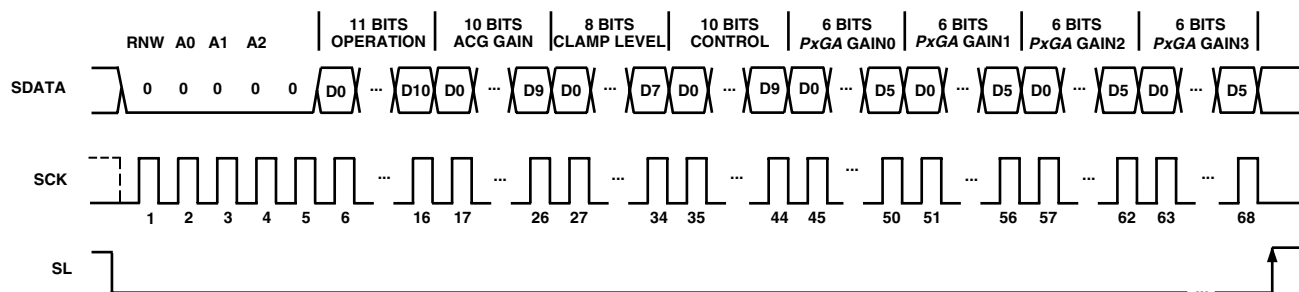

- NOTES:**
1. ANY NUMBER OF ADJACENT REGISTERS MAY BE LOADED SEQUENTIALLY, BEGINNING WITH THE LOWEST ADDRESS AND INCREMENTING ONE ADDRESS AT A TIME.
 2. WHEN SEQUENTIALLY LOADING MULTIPLE REGISTERS, THE EXACT REGISTER LENGTH (SHOWN ABOVE) MUST BE USED FOR EACH REGISTER.
 3. ALL LOADED REGISTERS WILL BE SIMULTANEOUSLY UPDATED WITH THE RISING EDGE OF SL.

Figure 23. Continuous Serial Write Operation to All Registers

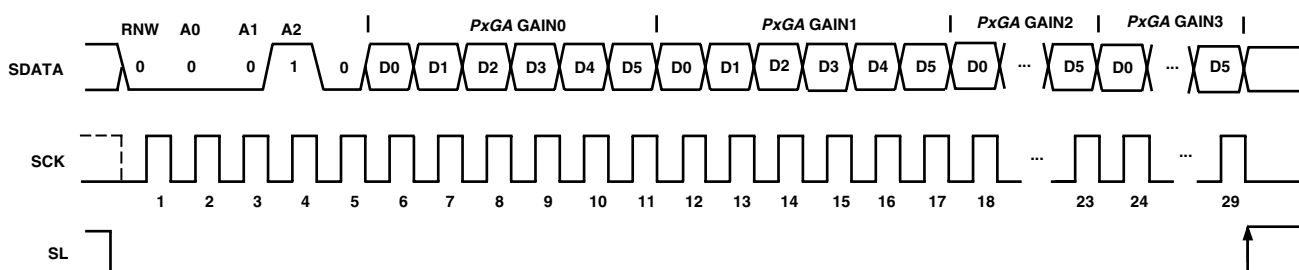

Figure 24. Continuous Serial Write Operation to All PxGA Gain Registers

Table II. Operation Register Contents (Default Value x000)

D10	D9	D8	D7	D6	Optical Black Clamp D5	Reset D4	Power-Down Modes D3 D2	Channel Selection D1 D0
0*	0*	0*	1**	0*	0 Enable Clamping 1 Disable Clamping	0 Normal 1 Reset All Registers to Default	0 0 Normal Power 0 1 Fast Recovery 1 0 Standby 1 1 Total Power-Down	0 0 CCD Mode 0 1 AUX1 Mode 1 0 AUX2 Mode 1 1 Test Only

*Must be set to zero.
**Set to one.

Table III. VGA Gain Register Contents (Default Value x096)

D10	MSB D9	D8	D7	D6	D5	D4	D3	D2	D1	LSB D0	Gain (dB)
X	0	0	0	1	0	1	1	1	1	1	2.0
					•						•
					•						•
	1	1	1	1	1	1	1	1	1	0	35.965
	1	1	1	1	1	1	1	1	1	1	36.0

AD9846A

Table IV. Clamp Level Register Contents (Default Value x080)

D10	D9	D8	MSB							LSB	Clamp Level (LSB)	
			D7	D6	D5	D4	D3	D2	D1	D0		
X	X	X	0	0	0	0	0	0	0	0	0	0
			0	0	0	0	0	0	0	0	1	0.25
			0	0	0	0	0	0	1	0	0	0.5
												•
												•
												•
			1	1	1	1	1	1	1	0	63.5	
			1	1	1	1	1	1	1	1	63.75	

Table V. Control Register Contents (Default Value x000)

D10	Data Out	D8	D7	DATACLK	CLP/PBLK	SHP/SHD	PxGA	Color Steering Modes				
	D9			D6	D5	D4	D3**	D2	D1	D0		
X	0 Enable	0*	0*	0 Rising Edge Trigger	0 Active Low	0 Active Low	0 Disable	0	0	0	Steering Disabled	
	1 Three-State			1 Falling Edge Trigger	1 Active High	1 Active High	1 Enable	0	0	1	Mosaic Separate	
									0	1	0	Interlace
									0	1	1	3-Color
									1	0	0	4-Color
									1	0	1	VD Selected
									1	1	0	Mosaic Repeat
						1	1	1	User Specified			

*Must be set to zero.

**When D3 = 0 (PxGA disabled) the PxGA gain is fixed to 4 dB.

Table VI. PxGA Gain Registers for Gain0, Gain1, Gain2, Gain3 (Default Value x000)

D10	D9	D8	D7	D6	MSB					LSB	Gain (dB)*		
					D5	D4	D3	D2	D1	D0			
X	X	X	X	X	0	1	1	1	1	1	1	+10.0	
													•
													•
													•
													•
										0	0	0	0
					1	1	1	1	1	+4.0			
										•			
										•			
										•			
					1	0	0	0	0	0	-2.0		

*Control Register Bit D3 must be set High (PxGA Enable) to use the PxGA Gain Registers.

CIRCUIT DESCRIPTION AND OPERATION

The AD9846A signal processing chain is shown in Figure 25. Each processing step is essential in achieving a high-quality image from the raw CCD pixel data.

DC Restore

To reduce the large dc offset of the CCD output signal, a dc-restore circuit is used with an external 0.1 μF series coupling capacitor. This restores the dc level of the CCD signal to approximately 1.5 V, to be compatible with the 3 V single supply of the AD9846A.

Correlated Double Sampler

The CDS circuit samples each CCD pixel twice to extract the video information and reject low-frequency noise. The timing shown in Figure 5 illustrates how the two CDS clocks, SHP and SHD, are used to sample the reference level and data level of the CCD signal respectively. The CCD signal is sampled on the rising edges of SHP and SHD. Placement of these two clock signals is critical in achieving the best performance from the CCD. An internal SHP/SHD delay (t_{HD}) of 3 ns is caused by internal propagation delays.

Input Clamp

A line-rate input clamping circuit is used to remove the CCD's optical black offset. This offset exists in the CCD's shielded black reference pixels. Unlike some AFE architectures, the AD9846A removes this offset in the input stage to minimize the effect of a

gain change on the system black level, usually called the "gain step." Another advantage of removing this offset at the input stage is to maximize system headroom. Some area CCDs have large black level offset voltages, which, if not corrected at the input stage, can significantly reduce the available headroom in the internal circuitry when higher VGA gain settings are used.

Horizontal timing is shown in Figure 6. It is recommended that the CLPDM pulse be used during valid CCD dark pixels. CLPDM may be used during the optical black pixels, either together with CLPOB or separately. The CLPDM pulse should be a minimum of 4 pixels wide.

PxGA

The PxGA provides separate gain adjustment for the individual color pixels. A programmable gain amplifier with four separate values, the PxGA has the capability to "multiplex" its gain value on a pixel-to-pixel basis. This allows lower output color pixels to be gained up to match higher output color pixels. Also, the PxGA may be used to adjust the colors for white balance, reducing the amount of digital processing that is needed. The four different gain values are switched according to the "Color Steering" circuitry. Seven different color steering modes for different types of CCD color filter arrays are programmed in the AD9846A's Control Register. For example, Mosaic Separate steering mode accommodates the popular "Bayer" arrangement of Red, Green, and Blue filters (see Figure 26).

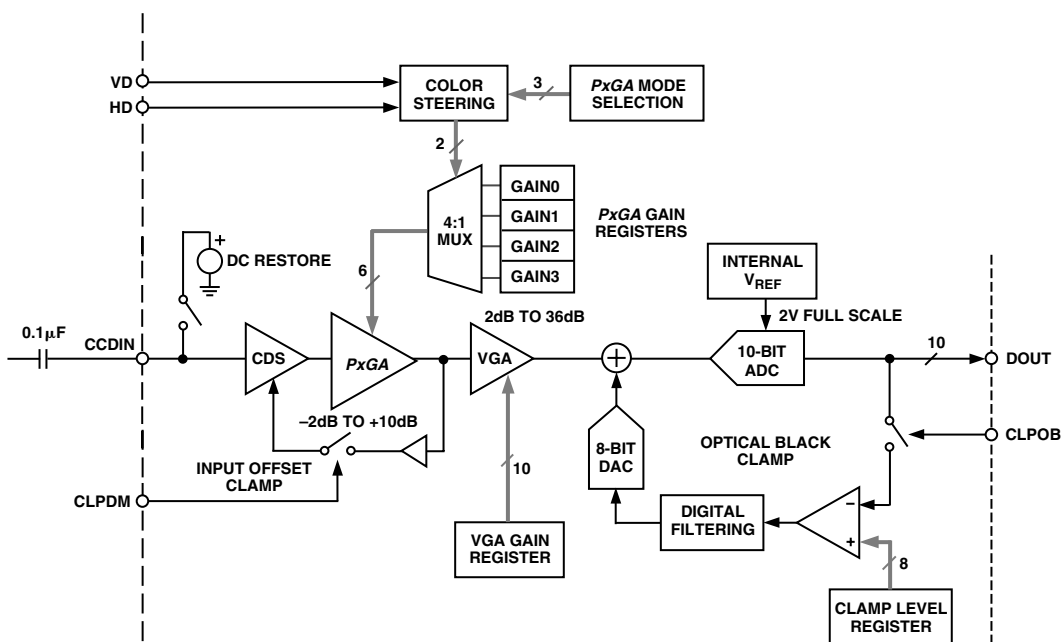

Figure 25. CCD-Mode Block Diagram

AD9846A

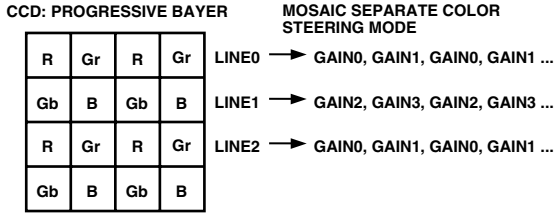

Figure 26. CCD Color Filter Example: Progressive Scan

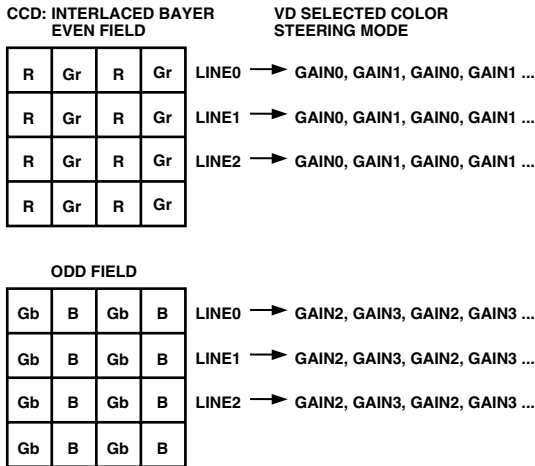

Figure 27. CCD Color Filter Example: Interlaced

The same Bayer pattern can also be interlaced, and the VD Selected mode should be used with this type of CCD (see Figure 27). The Color Steering performs the proper multiplexing of the R, G, and B gain values (loaded into the *PxGA* gain registers), and is synchronized by the user with vertical (VD) and horizontal (HD) sync pulses. For more detailed information, see the *PxGA* Timing section. The *PxGA* gain for each of the four channels is variable from -2 dB to +10 dB, controlled in 64 steps through the serial interface. The *PxGA* gain curve is shown in Figure 28.

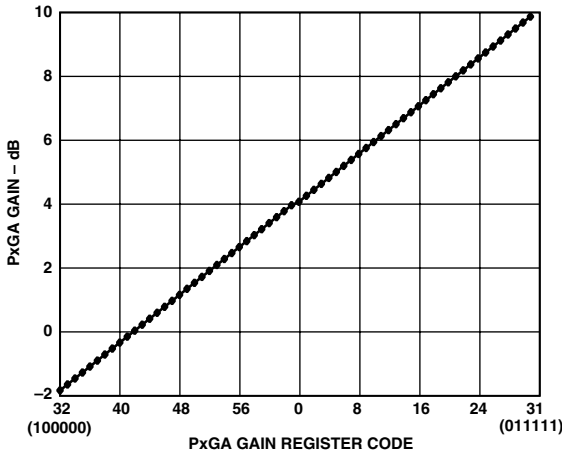

Figure 28. *PxGA* Gain Curve

Variable Gain Amplifier

The VGA stage provides a gain range of 2 dB to 36 dB, programmable with 10-bit resolution through the serial digital interface. Combined with 4 dB from the *PxGA* stage, the total gain range

for the AD9846A is 6 dB to 40 dB. The minimum gain of 6 dB is needed to match a 1 V input signal with the ADC full-scale range of 2 V. When compared to 1 V full-scale systems (such as ADI's AD9803), the equivalent gain range is 0 dB to 34 dB.

The VGA gain curve is divided into two separate regions. When the VGA Gain Register code is between 0 and 511, the curve follows a $(1+x)/(1-x)$ shape, which is similar to a "linear-in-dB" characteristic. From code 512 to code 1023, the curve follows a "linear-in-dB" shape. The exact VGA gain can be calculated for any Gain Register value by using the following two equations:

Code Range Gain Equation (dB)

0–511	$Gain = 20 \log_{10} \left(\frac{658 + code}{658 - code} \right) - 0.4$
512–1023	$Gain = (0.0354)(code) - 0.4$

As shown in the CCD Mode Specifications, only the VGA gain range from 2 dB to 36 dB has tested and guaranteed accuracy. This corresponds to a VGA gain code range of 91 to 1023. The Gain Accuracy Specifications also include the *PxGA* gain of 4 dB, for a total gain range of 6 dB to 40 dB.

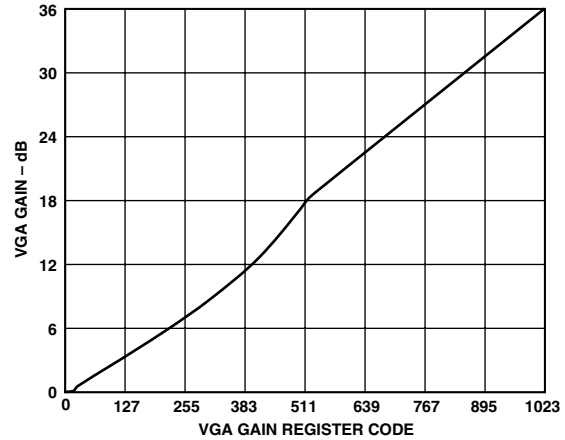

Figure 29. VGA Gain Curve (Gain from *PxGA* Not Included)

Optical Black Clamp

The optical black clamp loop is used to remove residual offsets in the signal chain, and to track low-frequency variations in the CCD's black level. During the optical black (shielded) pixel interval on each line, the ADC output is compared with a fixed black level reference, selected by the user in the Clamp Level Register. Any value between 0 LSB and 64 LSB may be programmed, with 8-bit resolution. The resulting error signal is filtered to reduce noise, and the correction value is applied to the ADC input through a D/A converter. Normally, the optical black clamp loop is turned on once per horizontal line, but this loop can be updated more slowly to suit a particular application. If external digital clamping is used during the post processing, the AD9846A's optical black clamping may be disabled using Bit D5 in the Operation Register (see Serial Interface Timing and Internal Register Description section). When the loop is disabled, the Clamp Level Register may still be used to provide programmable offset adjustment.

Horizontal timing is shown in Figure 6. The CLPOB pulse should be placed during the CCD's optical black pixels. It is recommended that the CLPOB pulse duration be at least 20 pixels wide to minimize clamp noise. Shorter pulsewidths may be used, but clamp noise may increase, and the ability to track low-frequency variations in the black level will be reduced.

A/D Converter

The AD9846A uses high-performance ADC architecture, optimized for high speed and low power. Differential Nonlinearity (DNL) performance is typically better than 0.5 LSB, as shown in TPC 2. Instead of the 1 V full-scale range used by the earlier AD9801 and AD9803 products from Analog Devices, the AD9846A ADC uses a 2 V input range. Better noise performance results from using a larger ADC full-scale range (see TPC 3).

AUX1 Mode

For applications that do not require CDS, the AD9846A can be configured to sample ac-coupled waveforms. Figure 30 shows the circuit configuration for using the AUX1 channel input (Pin 36). A single 0.1 μF ac-coupling capacitor is needed between the input signal driver and the AUX1IN pin. An on-chip dc-bias circuit sets the average value of the input signal to approximately 0.4 V, which is referenced to the midscale code of the ADC. The VGA Gain register provides a gain range of 0 dB to 36 dB in this mode of operation (see VGA Gain Curve, Figure 29). The VGA gains up the signal level with respect to the 0.4 V bias

level. Signal levels above the bias level will be further increased to a higher ADC code, while signal levels below the bias level will be further decreased to a lower ADC code.

AUX2 Mode

For sampling video-type waveforms, such as NTSC and PAL signals, the AUX2 channel provides black level clamping, gain adjustment, and A/D conversion. Figure 31 shows the circuit configuration for using the AUX2 channel input (Pin 34). A external 0.1 μF blocking capacitor is used with the on-chip video clamp circuit, to level-shift the input signal to a desired reference level. The clamp circuit automatically senses the most negative portion of the input signal, and adjusts the voltage across the input capacitor. This forces the black level of the input signal to be equal to the value programmed into the Clamp Level register (see Serial Interface Register Description). The VGA provides gain adjustment from 0 dB to 18 dB. The same VGA Gain register is used, but only the 9 MSBs of the gain register are used (see Table VII.)

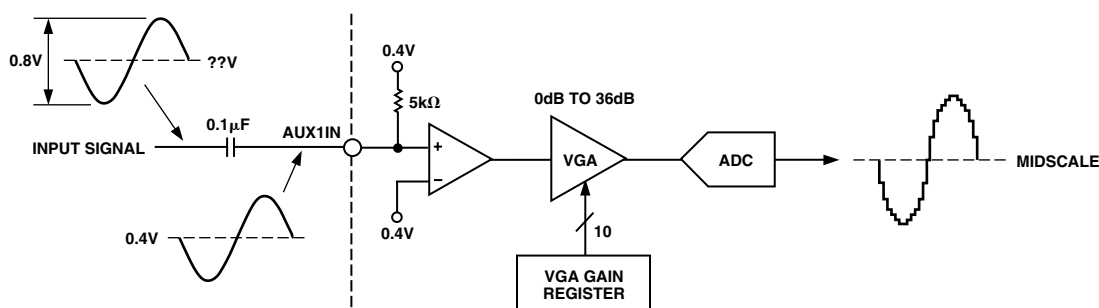

Figure 30. AUX1 Circuit Configuration

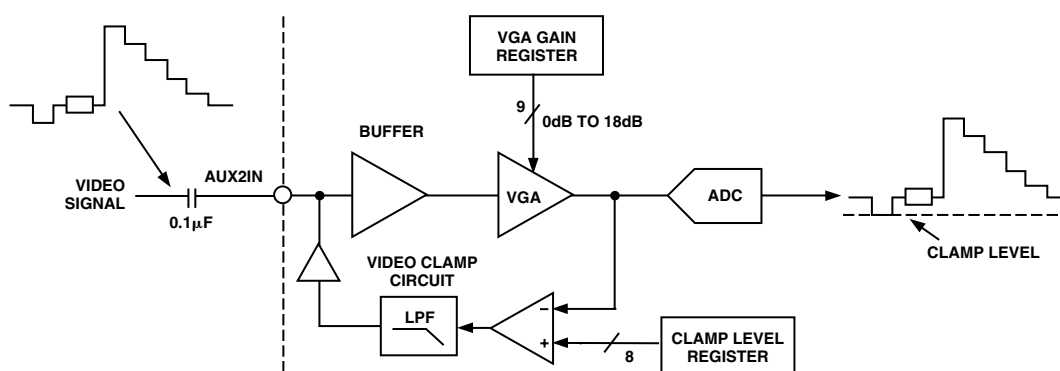

Figure 31. AUX2 Circuit Configuration

Table VII. VGA Gain Register Used for AUX2-Mode

D10	MSB										LSB	Gain (dB)
	D9	D8	D7	D6	D5	D4	D3	D2	D1	D0		
X	0	X	X	X	X	X	X	X	X	X	0.0	
	1	0	0	0	0	0	0	0	0	0	0.0	
					⋮						⋮	
					⋮						⋮	
	1	1	1	1	1	1	1	1	1	1	18.0	

AD9846A

APPLICATIONS INFORMATION

The AD9846A is a complete Analog Front End (AFE) product for digital still camera and camcorder applications. As shown in Figure 32, the CCD image (pixel) data is buffered and sent to the AD9846A analog input through a series input capacitor. The AD9846A performs the dc restoration, CDS, gain adjustment, black level correction, and analog-to-digital conversion. The AD9846A's digital output data is then processed by the image

processing ASIC. The internal registers of the AD9846A—used to control gain, offset level, and other functions—are programmed by the ASIC or microprocessor through a 3-wire serial digital interface. A system timing generator provides the clock signals for both the CCD and the AFE.

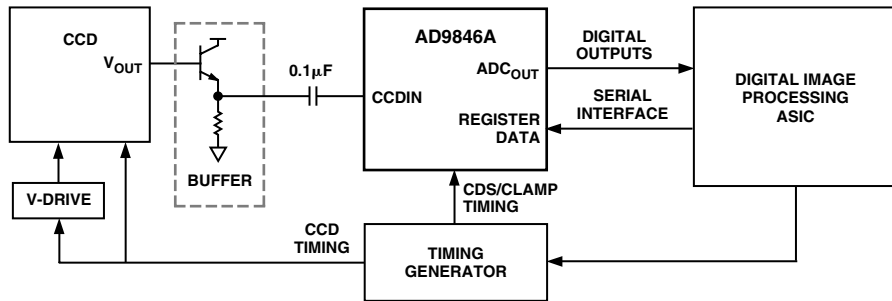
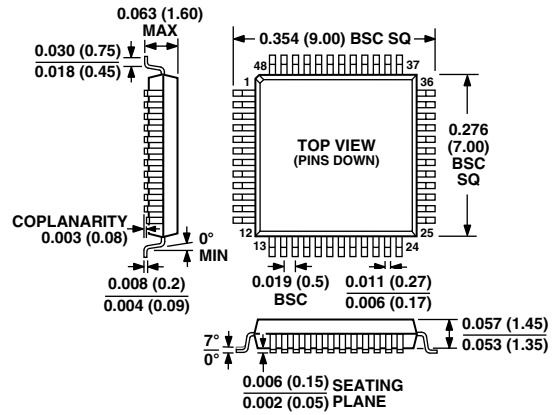

Figure 32. System Applications Diagram

OUTLINE DIMENSIONS

Dimensions shown in inches and (mm).

48-Lead LQFP (ST-48)



Looking for pricing, stock, or lifecycle information?

Click below to explore more details on WIN SOURCE:

 [View AD9846AJSTZ on WIN SOURCE](#)

 [Analog Devices Inc. Information](#)

Optimize Your Supply Chain with WIN SOURCE Solutions

-  Global Sourcing Solution
-  Obsolete Management
-  Cost Control Management
-  Shortage Management
-  Alternative Solution
-  Excess Inventory Management