



**THE DATASHEET OF  
ADG5243FBRUZ-RL7**



User Defined Fault Protection and Detection, 0.8 pC  $Q_{INJ}$ , Triple SPDT

**FEATURES**

- ▶ User defined supplies set overvoltage level
  - ▶ Overvoltage protection up to -55 V and +55 V
  - ▶ Power-off protection up to -55 V and +55 V
  - ▶ Overvoltage detection on source pins
  - ▶ Minimum secondary supply level: 4.5 V single-supply
  - ▶ Interrupt flags indicate fault status
- ▶ Low charge injection ( $Q_{INJ}$ ): 0.8 pC
- ▶ Low drain/source on capacitance: 10 pF
- ▶ Latch-up immune under any circumstance
- ▶ Known state without digital inputs present
- ▶  $V_{SS}$  to  $V_{DD}$  analog signal range
  - ▶  $\pm 5$  V to  $\pm 22$  V dual supply operation
  - ▶ 8 V to 44 V single-supply operation
  - ▶ Fully specified at  $\pm 15$  V,  $\pm 20$  V, +12 V, and +36 V

**APPLICATIONS**

- ▶ Analog input/output modules
- ▶ Process control/distributed control systems
- ▶ Data acquisition
- ▶ Instrumentation
- ▶ Avionics
- ▶ Automatic test equipment
- ▶ Communication systems
- ▶ Relay replacement

**GENERAL DESCRIPTION**

The ADG5243F comprises three independently selectable, single-pole/double-throw (SPDT) switches. All channels exhibit break-before-make switching action that prevents momentary shorting when switching channels. An  $\overline{EN}$  input enables or disables the device. When disabled, all channels are switched off. Each switch conducts equally well in both directions when on, and each switch has an input signal range that extends to the supplies. The primary supply voltages define the on-resistance profile, whereas the secondary supply voltages define the voltage level at which the overvoltage protection engages.

When no power supplies are present, the channel remains in the off condition, and the switch inputs are high impedance. Under normal operating conditions, if the analog input signal levels on any  $S_x$  pin exceed the positive fault voltage (POSFV) or the negative fault voltage (NEGFV) by a threshold voltage ( $V_T$ ), the channel turns off and that  $S_x$  pin becomes high impedance. If the switch is selected to be on, then the drain pin is pulled to the secondary supply voltage that was exceeded. Input signal levels up to -55 V or +55 V

**FUNCTIONAL BLOCK DIAGRAM**

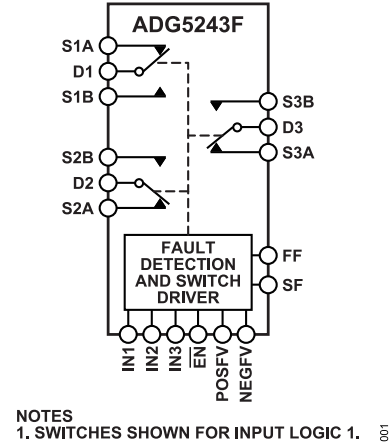

Figure 1.

**PRODUCT HIGHLIGHTS**

1. The source pins are protected against voltages greater than the secondary supply rails, up to -55 V and +55 V.
2. The source pins are protected against voltages between -55 V and +55 V in an unpowered state.
3. Overvoltage detection with the digital output indicates the operating state of the switches.
4. Trench isolation guards against latch-up.
5. Optimized for low charge injection and on-capacitance.
6. The ADG5243F can be operated from a dual supply of  $\pm 5$  V to  $\pm 22$  V or a single power supply of 8 V to 44 V.

relative to ground are blocked, in both the powered and unpowered conditions.

The low capacitance and charge injection of these switches make them ideal solutions for data acquisition and sample-and-hold applications, where low glitch switching and fast settling times are required.

Note that, throughout this data sheet, multifunction pins, such as IN1/F1, are referred to either by the entire pin name or by a single function of the pin, for example, IN1, when only that function is relevant.

**TABLE OF CONTENTS**

Features.....	1	Terminology.....	24
Applications.....	1	Theory of Operation.....	26
Functional Block Diagram.....	1	Switch Architecture.....	26
Product Highlights.....	1	User Defined Fault Protection.....	26
General Description.....	1	Applications Information.....	28
Specifications.....	3	Power Supply Rails.....	28
±15 V Dual Supply.....	3	Power Supply Sequencing Protection.....	28
±20 V Dual Supply.....	5	Signal Range.....	28
12 V Single Supply.....	7	Power Supply Recommendations.....	28
36 V Single Supply.....	9	High Voltage Surge Suppression.....	28
Continuous Current per Channel, Sx or Dx.....	11	Intelligent Fault Detection.....	28
Absolute Maximum Ratings.....	12	Large Voltage, High Frequency Signals.....	29
ESD Caution.....	12	Outline Dimensions.....	30
Pin Configurations and Function Descriptions.....	13	Ordering Guide.....	30
Typical Performance Characteristics.....	15	Evaluation Boards.....	30
Test Circuits.....	20		

**REVISION HISTORY****6/2023—Rev. B to Rev. C**

Changes to Table 1.....	3
Changes to Table 2.....	5
Changes to Table 3.....	7
Changes to Table 4.....	9

**11/2022—Rev. A to Rev. B**

Changes to Drain Leakage Current, $I_D$ , With Overvoltage Parameter; Table 2.....	5
Updated Outline Dimensions.....	30

## SPECIFICATIONS

## ±15 V DUAL SUPPLY

$V_{DD} = 15\text{ V} \pm 10\%$ ,  $V_{SS} = -15\text{ V} \pm 10\%$ ,  $GND = 0\text{ V}$ ,  $C_{DECOUPLING} = 0.1\text{ }\mu\text{F}$ , unless otherwise noted.

Table 1.

Parameter	+25°C	-40°C to +85°C	-40°C to +125°C	Unit	Test Conditions/Comments
<b>ANALOG SWITCH</b>					
Analog Signal Range			$V_{DD}$ to $V_{SS}$	V	$V_{DD} = +13.5\text{ V}$ , $V_{SS} = -13.5\text{ V}$ , see <a href="#">Figure 35</a>
On Resistance, $R_{ON}$	250			$\Omega$ typ	$V_S = \pm 10\text{ V}$ , $I_S = -1\text{ mA}$
	270	335	395	$\Omega$ max	
On-Resistance Match Between Channels, $\Delta R_{ON}$	250			$\Omega$ typ	$V_S = \pm 9\text{ V}$ , $I_S = -1\text{ mA}$
	270	335	395	$\Omega$ max	
	1			$\Omega$ typ	
	8	9	9	$\Omega$ max	
On-Resistance Flatness, $R_{FLAT(ON)}$	1			$\Omega$ typ	$V_S = \pm 10\text{ V}$ , $I_S = -1\text{ mA}$
	8	9	9	$\Omega$ max	
	7			$\Omega$ typ	
	8.5	9.5	9.5	$\Omega$ max	
Threshold Voltage, $V_T$	1.5			$\Omega$ typ	$V_S = \pm 9\text{ V}$ , $I_S = -1\text{ mA}$
	3.5	4.5	4.5	$\Omega$ max	
	0.7			V typ	
<b>LEAKAGE CURRENTS</b>					
Source Off Leakage, $I_S$ (Off)	$\pm 0.1$			nA typ	$V_{DD} = +16.5\text{ V}$ , $V_{SS} = -16.5\text{ V}$ $V_S = \pm 10\text{ V}$ , $V_D = \mp 10\text{ V}$ , see <a href="#">Figure 33</a>
	$\pm 1$	$\pm 2$	$\pm 5$	nA max	
Drain Off Leakage, $I_D$ (Off)	$\pm 0.1$			nA typ	$V_S = \pm 10\text{ V}$ , $V_D = \mp 10\text{ V}$ , see <a href="#">Figure 33</a>
	$\pm 1$	$\pm 2$	$\pm 5$	nA max	
Channel On Leakage, $I_D$ (On), $I_S$ (On)	$\pm 0.3$			nA typ	$V_S = V_D = \pm 10\text{ V}$ , see <a href="#">Figure 34</a>
	$\pm 1.5$	$\pm 5$	$\pm 10$	nA max	
<b>FAULT</b>					
Source Leakage Current, $I_S$ With Overvoltage	$\pm 66$		$\pm 78$	$\mu\text{A}$ typ	$V_{DD} = +16.5\text{ V}$ , $V_{SS} = -16.5\text{ V}$ , $GND = 0\text{ V}$ , $V_S = \pm 55\text{ V}$ , see <a href="#">Figure 32</a>
	$\pm 25$		$\pm 40$	$\mu\text{A}$ typ	
Power Supplies Grounded or Floating					$V_{DD} = 0\text{ V}$ or floating, $V_{SS} = 0\text{ V}$ or floating, $GND = 0\text{ V}$ , $INx = 0\text{ V}$ or floating, $V_S = \pm 55\text{ V}$ , see <a href="#">Figure 31</a>
Drain Leakage Current, $I_D$ With Overvoltage	$\pm 2$			nA typ	$V_{DD} = +16.5\text{ V}$ , $V_{SS} = -16.5\text{ V}$ , $GND = 0\text{ V}$ , $V_S = \pm 55\text{ V}$ , see <a href="#">Figure 32</a>
	$\pm 8$	$\pm 15$	$\pm 50$	nA max	
Power Supplies Grounded	$\pm 5$			nA typ	$V_{DD} = 0\text{ V}$ , $V_{SS} = 0\text{ V}$ , $GND = 0\text{ V}$ , $V_S = \pm 55\text{ V}$ , $INx = 0\text{ V}$ , see <a href="#">Figure 31</a>
Power Supplies Floating	$\pm 100$	$\pm 100$	$\pm 100$	nA max	$V_{DD} = \text{floating}$ , $V_{SS} = \text{floating}$ , $GND = 0\text{ V}$ , $V_S = \pm 55\text{ V}$ , $INx = 0\text{ V}$ , see <a href="#">Figure 31</a>
	$\pm 50$	$\pm 50$	$\pm 50$	$\mu\text{A}$ typ	
<b>DIGITAL INPUTS/OUTPUTS</b>					
Input Voltage High, $V_{INH}$			2.0	V min	$V_{IN} = GND$ or $V_{DD}$
			0.8	V max	
Input Current, $I_{INL}$ or $I_{INH}$	$\pm 0.7$			$\mu\text{A}$ typ	
	$\pm 1.1$		$\pm 1.2$	$\mu\text{A}$ max	
Digital Input Capacitance, $C_{IN}$	5.0			pF typ	

## SPECIFICATIONS

Table 1. (Continued)

Parameter	+25°C	-40°C to +85°C	-40°C to +125°C	Unit	Test Conditions/Comments
Output Voltage					
High, $V_{OH}$	2.0			V min	
Low, $V_{OL}$	0.4			V max	
<b>DYNAMIC CHARACTERISTICS</b>					
Transition Time, $t_{TRANSITION}$	160			ns typ	$R_L = 1\text{ k}\Omega$ , $C_L = 35\text{ pF}$
	195	210	215	ns max	$V_S = 10\text{ V}$ , see Figure 47
$t_{ON}(\overline{EN})$	165			ns typ	$R_L = 1\text{ k}\Omega$ , $C_L = 35\text{ pF}$
	205	220	230	ns max	$V_S = 10\text{ V}$ , see Figure 46
$t_{OFF}(\overline{EN})$	70			ns typ	$R_L = 1\text{ k}\Omega$ , $C_L = 35\text{ pF}$
	90	110	110	ns max	$V_S = 10\text{ V}$ , see Figure 46
Break-Before-Make Time Delay, $t_D$	115			ns typ	$R_L = 1\text{ k}\Omega$ , $C_L = 35\text{ pF}$
			85	ns min	$V_S = 10\text{ V}$ , see Figure 45
Overvoltage Response Time, $t_{RESPONSE}$	90			ns typ	$R_L = 1\text{ k}\Omega$ , $C_L = 5\text{ pF}$ , see Figure 40
	115	130	130	ns max	
Overvoltage Recovery Time, $t_{RECOVERY}$	745			ns typ	$R_L = 1\text{ k}\Omega$ , $C_L = 5\text{ pF}$ , see Figure 41
	945	965	970	ns max	
Interrupt Flag Response Time, $t_{DIGRESP}$	90			ns typ	$C_L = 12\text{ pF}$ , see Figure 42
Interrupt Flag Recovery Time, $t_{DIGREC}$	65			$\mu\text{s}$ typ	$C_L = 12\text{ pF}$ , see Figure 43
	900			ns typ	$C_L = 12\text{ pF}$ , $R_{PULLUP} = 1\text{ k}\Omega$ , see Figure 44
Charge Injection, $Q_{INJ}$	-0.8			pC typ	$V_S = 0\text{ V}$ , $R_S = 0\ \Omega$ , $C_L = 1\text{ nF}$ , see Figure 48
Off Isolation	-74			dB typ	$R_L = 50\ \Omega$ , $C_L = 5\text{ pF}$ , $f = 1\text{ MHz}$ , see Figure 37
Channel-to-Channel Crosstalk	-83			dB typ	$R_L = 50\ \Omega$ , $C_L = 5\text{ pF}$ , $f = 1\text{ MHz}$ , see Figure 39
Total Harmonic Distortion Plus Noise, THD + N	0.005			% typ	$R_L = 10\text{ k}\Omega$ , $V_S = 15\text{ V p-p}$ , $f = 20\text{ Hz}$ to $20\text{ kHz}$ , see Figure 36
-3 dB Bandwidth	350			MHz typ	$R_L = 50\ \Omega$ , $C_L = 5\text{ pF}$ , see Figure 38
Insertion Loss	10.5			dB typ	$R_L = 50\ \Omega$ , $C_L = 5\text{ pF}$ , $f = 1\text{ MHz}$ , see Figure 38
$C_S$ (Off)	4			pF typ	$V_S = 0\text{ V}$ , $f = 1\text{ MHz}$
$C_D$ (Off)	4			pF typ	$V_S = 0\text{ V}$ , $f = 1\text{ MHz}$
$C_D$ (On), $C_S$ (On)	10			pF typ	$V_S = 0\text{ V}$ , $f = 1\text{ MHz}$
<b>POWER REQUIREMENTS</b>					
$V_{DD} = \text{POSFV} = +16.5\text{ V}$ , $V_{SS} = \text{NEGFV} = -16.5\text{ V}$ , $GND = 0\text{ V}$ , digital inputs = $0\text{ V}$ , $5\text{ V}$ , or $V_{DD}$					
<b>Normal Mode</b>					
$I_{DD}$	1.3			mA typ	
$I_{\text{POSFV}}$	0.15			mA typ	
$I_{DD} + I_{\text{POSFV}}$	2.15		2.25	mA max	
$I_{GND}$	0.75			mA typ	
	1.4		1.55	mA max	
$I_{SS}$	0.65			mA typ	
$I_{\text{NEGFV}}$	0.2			mA typ	
$I_{SS} + I_{\text{NEGFV}}$	0.95		1.0	mA max	
<b>Fault Mode</b>					
$I_{DD}$	1.4			mA typ	$V_S = \pm 55\text{ V}$ , all channels in fault
$I_{\text{POSFV}}$	0.2			mA typ	
$I_{DD} + I_{\text{POSFV}}$	2.5		2.8	mA max	
$I_{GND}$	0.9			mA typ	
	1.8		1.9	mA max	
$I_{SS}$	0.55			mA typ	
$I_{\text{NEGFV}}$	0.2			mA typ	

## SPECIFICATIONS

Table 1. (Continued)

Parameter	+25°C	-40°C to +85°C	-40°C to +125°C	Unit	Test Conditions/Comments
$I_{SS} + I_{NEG\overline{V}}$	1.2		1.3	mA max	
$V_{DD}/V_{SS}$			±5	V min	GND = 0 V
			±22	V max	GND = 0 V

## ±20 V DUAL SUPPLY

$V_{DD} = 20\text{ V} \pm 10\%$ ,  $V_{SS} = -20\text{ V} \pm 10\%$ , GND = 0 V,  $C_{\text{DECOUPLING}} = 0.1\ \mu\text{F}$ , unless otherwise noted.

Table 2.

Parameter	+25°C	-40°C to +85°C	-40°C to +125°C	Unit	Test Conditions/Comments
ANALOG SWITCH					$V_{DD} = +18\text{ V}$ , $V_{SS} = -18\text{ V}$ , see <a href="#">Figure 35</a>
Analog Signal Range			$V_{DD}$ to $V_{SS}$	V	
On Resistance, $R_{ON}$	270			Ω typ	$V_S = \pm 15\text{ V}$ , $I_S = -1\text{ mA}$
	290	355	410	Ω max	
	250			Ω typ	$V_S = \pm 13.5\text{ V}$ , $I_S = -1\text{ mA}$
	270	335	395	Ω max	
On-Resistance Match Between Channels, $\Delta R_{ON}$	1			Ω typ	$V_S = \pm 15\text{ V}$ , $I_S = -1\text{ mA}$
	8	9	9	Ω max	
	1			Ω typ	$V_S = \pm 13.5\text{ V}$ , $I_S = -1\text{ mA}$
	8	9	9	Ω max	
On-Resistance Flatness, $R_{\text{FLAT(ON)}}$	27			Ω typ	$V_S = \pm 15\text{ V}$ , $I_S = -1\text{ mA}$
	29.5	29.5	29.5	Ω max	
	5			Ω typ	$V_S = \pm 13.5\text{ V}$ , $I_S = -1\text{ mA}$
	6.5	8.5	8.5	Ω max	
Threshold Voltage, $V_T$	0.7			V typ	See <a href="#">Figure 27</a>
LEAKAGE CURRENTS					$V_{DD} = +22\text{ V}$ , $V_{SS} = -22\text{ V}$
Source Off Leakage, $I_S$ (Off)	±0.1			nA typ	$V_S = \pm 15\text{ V}$ , $V_D = \mp 15\text{ V}$ , see <a href="#">Figure 33</a>
	±1	±2	±5	nA max	
Drain Off Leakage, $I_D$ (Off)	±0.1			nA typ	$V_S = \pm 15\text{ V}$ , $V_D = \mp 15\text{ V}$ , see <a href="#">Figure 33</a>
	±1	±2	±5	nA max	
Channel On Leakage, $I_D$ (On), $I_S$ (On)	±0.3			nA typ	$V_S = V_D = \pm 15\text{ V}$ , see <a href="#">Figure 34</a>
	±1.5	±5	±10	nA max	
FAULT					
Source Leakage Current, $I_S$					
With Overvoltage	±66			μA typ	$V_{DD} = +22\text{ V}$ , $V_{SS} = -22\text{ V}$ , GND = 0 V, $V_S = \pm 55\text{ V}$ , see <a href="#">Figure 32</a>
Power Supplies Grounded or Floating	±25			μA typ	$V_{DD} = 0\text{ V}$ or floating, $V_{SS} = 0\text{ V}$ or floating, GND = 0 V, $I_{NX} = 0\text{ V}$ or floating, $V_S = \pm 55\text{ V}$ , see <a href="#">Figure 31</a>
Drain Leakage Current, $I_D$					
With Overvoltage	±2			nA typ	$V_{DD} = +22\text{ V}$ , $V_{SS} = -22\text{ V}$ , GND = 0 V, $V_S = \pm 55\text{ V}$ , see <a href="#">Figure 32</a>
	±2	±2	±2	μA max	
Power Supplies Grounded	±5			nA typ	$V_{DD} = 0\text{ V}$ , $V_{SS} = 0\text{ V}$ , GND = 0 V, $V_S = \pm 55\text{ V}$ , $I_{NX} = 0\text{ V}$ , see <a href="#">Figure 31</a>
	±100	±100	±100	nA max	
Power Supplies Floating	±50	±50	±50	μA typ	$V_{DD} = \text{floating}$ , $V_{SS} = \text{floating}$ , GND = 0 V, $V_S = \pm 55\text{ V}$ , $I_{NX} = 0\text{ V}$ , see <a href="#">Figure 31</a>

## SPECIFICATIONS

Table 2. (Continued)

Parameter	+25°C	-40°C to +85°C	-40°C to +125°C	Unit	Test Conditions/Comments	
<b>DIGITAL INPUTS/OUTPUTS</b>						
Input Voltage						
High, $V_{INH}$			2.0	V min		
Low, $V_{INL}$			0.8	V max		
Input Current, $I_{INL}$ or $I_{INH}$	±0.7			µA typ	$V_{IN} = GND$ or $V_{DD}$	
	±1.1		±1.2	µA max		
Digital Input Capacitance, $C_{IN}$	5.0			pF typ		
Output Voltage						
High, $V_{OH}$	2.0			V min		
Low, $V_{OL}$	0.4			V max		
<b>DYNAMIC CHARACTERISTICS</b>						
Transition Time, $t_{TRANSITION}$	165			ns typ	$R_L = 1\text{ k}\Omega$ , $C_L = 35\text{ pF}$	
	210	230	235	ns max	$V_S = 10\text{ V}$ , see <a href="#">Figure 47</a>	
$t_{ON}(\overline{EN})$	170			ns typ	$R_L = 1\text{ k}\Omega$ , $C_L = 35\text{ pF}$	
	215	240	250	ns max	$V_S = 10\text{ V}$ , see <a href="#">Figure 46</a>	
$t_{OFF}(\overline{EN})$	70			ns typ	$R_L = 1\text{ k}\Omega$ , $C_L = 35\text{ pF}$	
	85	115	115	ns max	$V_S = 10\text{ V}$ , see <a href="#">Figure 46</a>	
Break-Before-Make Time Delay, $t_D$	120			ns typ	$R_L = 1\text{ k}\Omega$ , $C_L = 35\text{ pF}$	
			85	ns min	$V_S = 10\text{ V}$ , see <a href="#">Figure 45</a>	
Overvoltage Response Time, $t_{RESPONSE}$	75			ns typ	$R_L = 1\text{ k}\Omega$ , $C_L = 5\text{ pF}$ , see <a href="#">Figure 40</a>	
	105	105	105	ns max		
Overvoltage Recovery Time, $t_{RECOVERY}$	820			ns typ	$R_L = 1\text{ k}\Omega$ , $C_L = 5\text{ pF}$ , see <a href="#">Figure 41</a>	
	1100	1250	1400	ns max		
Interrupt Flag Response Time, $t_{DIGRESP}$	75			ns typ	$C_L = 12\text{ pF}$ , see <a href="#">Figure 42</a>	
Interrupt Flag Recovery Time, $t_{DIGREC}$	65			µs typ	$C_L = 12\text{ pF}$ , see <a href="#">Figure 43</a>	
	1000			ns typ	$C_L = 12\text{ pF}$ , $R_{PULLUP} = 1\text{ k}\Omega$ , see <a href="#">Figure 44</a>	
Charge Injection, $Q_{INJ}$	-1.2			pC typ	$V_S = 0\text{ V}$ , $R_S = 0\text{ }\Omega$ , $C_L = 1\text{ nF}$ , see <a href="#">Figure 48</a>	
Off Isolation	-74			dB typ	$R_L = 50\text{ }\Omega$ , $C_L = 5\text{ pF}$ , $f = 1\text{ MHz}$ , see <a href="#">Figure 37</a>	
Channel-to-Channel Crosstalk	-82			dB typ	$R_L = 50\text{ }\Omega$ , $C_L = 5\text{ pF}$ , $f = 1\text{ MHz}$ , see <a href="#">Figure 39</a>	
Total Harmonic Distortion Plus Noise, THD + N	0.005			% typ	$R_L = 10\text{ k}\Omega$ , $V_S = 20\text{ V p-p}$ , $f = 20\text{ Hz to }20\text{ kHz}$ , see <a href="#">Figure 36</a>	
-3 dB Bandwidth	350			MHz typ	$R_L = 50\text{ }\Omega$ , $C_L = 5\text{ pF}$ , see <a href="#">Figure 38</a>	
Insertion Loss	10.5			dB typ	$R_L = 50\text{ }\Omega$ , $C_L = 5\text{ pF}$ , $f = 1\text{ MHz}$ , see <a href="#">Figure 38</a>	
$C_S$ (Off)	4			pF typ	$V_S = 0\text{ V}$ , $f = 1\text{ MHz}$	
$C_D$ (Off)	4			pF typ	$V_S = 0\text{ V}$ , $f = 1\text{ MHz}$	
$C_D$ (On), $C_S$ (On)	10			pF typ	$V_S = 0\text{ V}$ , $f = 1\text{ MHz}$	
<b>POWER REQUIREMENTS</b>						
Normal Mode						
$I_{DD}$	1.3			mA typ	$V_{DD} = \text{POSFV} = +22\text{ V}$ , $V_{SS} = \text{NEGFV} = -22\text{ V}$ , $GND = 0\text{ V}$ , digital inputs = 0 V, 5 V, or $V_{DD}$	
$I_{\text{POSFV}}$	0.15			mA typ		
$I_{DD} + I_{\text{POSFV}}$	2.15		2.25	mA max		
$I_{GND}$	0.75			mA typ		
	1.4		1.55	mA max		
$I_{SS}$	0.65			mA typ		
$I_{\text{NEGFV}}$	0.2			mA typ		
$I_{SS} + I_{\text{NEGFV}}$	1.0		1.0	mA max		
Fault Mode						
						$V_S = \pm 55\text{ V}$ , all channels in fault

## SPECIFICATIONS

Table 2. (Continued)

Parameter	+25°C	-40°C to +85°C	-40°C to +125°C	Unit	Test Conditions/Comments
$I_{DD}$	1.4			mA typ	
$I_{POSFV}$	0.2			mA typ	
$I_{DD} + I_{POSFV}$	2.5		2.8	mA max	
$I_{GND}$	0.9			mA typ	
	1.8		1.9	mA max	
$I_{SS}$	0.55			mA typ	
$I_{NEGFV}$	0.2			mA typ	
$I_{SS} + I_{NEGFV}$	1.2		1.3	mA max	
$V_{DD}/V_{SS}$			±5	V min	GND = 0 V
			±22	V max	GND = 0 V

## 12 V SINGLE SUPPLY

$V_{DD} = 12\text{ V} \pm 10\%$ ,  $V_{SS} = 0\text{ V}$ , GND = 0 V,  $C_{DECOUPLING} = 0.1\ \mu\text{F}$ , unless otherwise noted.

Table 3.

Parameter	+25°C	-40°C to +85°C	-40°C to +125°C	Unit	Test Conditions/Comments
<b>ANALOG SWITCH</b>					
Analog Signal Range			0 V to $V_{DD}$	V	$V_{DD} = 10.8\text{ V}$ , $V_{SS} = 0\text{ V}$ , see <a href="#">Figure 35</a>
On Resistance, $R_{ON}$	630			$\Omega$ typ	$V_S = 0\text{ V to } 8.5\text{ V}$ , $I_S = -1\text{ mA}$
	690	710	730	$\Omega$ max	
	270			$\Omega$ typ	$V_S = 3.5\text{ V to } 8.5\text{ V}$ , $I_S = -1\text{ mA}$
	290	355	410	$\Omega$ max	
On-Resistance Match Between Channels, $\Delta R_{ON}$	6			$\Omega$ typ	$V_S = 0\text{ V to } 8.5\text{ V}$ , $I_S = -1\text{ mA}$
	19	19	19	$\Omega$ max	
	1			$\Omega$ typ	$V_S = 3.5\text{ V to } 8.5\text{ V}$ , $I_S = -1\text{ mA}$
	8	8	8	$\Omega$ max	
On-Resistance Flatness, $R_{FLAT(ON)}$	380			$\Omega$ typ	$V_S = 0\text{ V to } 8.5\text{ V}$ , $I_S = -1\text{ mA}$
	440	460	460	$\Omega$ max	
	25			$\Omega$ typ	$V_S = 3.5\text{ V to } 8.5\text{ V}$ , $I_S = -1\text{ mA}$
	28	29	29	$\Omega$ max	
Threshold Voltage, $V_T$	0.7			V typ	See <a href="#">Figure 27</a>
<b>LEAKAGE CURRENTS</b>					
Source Off Leakage, $I_S$ (Off)	±0.1			nA typ	$V_{DD} = 13.2\text{ V}$ , $V_{SS} = 0\text{ V}$
	±1	±2	±5	nA max	$V_S = 1\text{ V}/10\text{ V}$ , $V_D = 10\text{ V}/1\text{ V}$ , see <a href="#">Figure 33</a>
Drain Off Leakage, $I_D$ (Off)	±0.1			nA typ	$V_S = 1\text{ V}/10\text{ V}$ , $V_D = 10\text{ V}/1\text{ V}$ , see <a href="#">Figure 33</a>
	±1	±2	±5	nA max	
Channel On Leakage, $I_D$ (On), $I_S$ (On)	±0.3			nA typ	$V_S = V_D = 1\text{ V}/10\text{ V}$ , see <a href="#">Figure 34</a>
	±1.5	±5	±10	nA max	
<b>FAULT</b>					
Source Leakage Current, $I_S$ With Overvoltage	±63			$\mu\text{A}$ typ	$V_{DD} = 13.2\text{ V}$ , $V_{SS} = 0\text{ V}$ , GND = 0 V, $V_S = \pm 55\text{ V}$ , see <a href="#">Figure 32</a>
Power Supplies Grounded or Floating	±25			$\mu\text{A}$ typ	$V_{DD} = 0\text{ V}$ or floating, $V_{SS} = 0\text{ V}$ or floating, GND = 0 V, $I_{NX} = 0\text{ V}$ or floating, $V_S = \pm 55\text{ V}$ , see <a href="#">Figure 31</a>
Drain Leakage Current, $I_D$ With Overvoltage	±2			nA typ	$V_{DD} = 13.2\text{ V}$ , $V_{SS} = 0\text{ V}$ , GND = 0 V, $V_S = \pm 55\text{ V}$ , see <a href="#">Figure 32</a>

## SPECIFICATIONS

Table 3. (Continued)

Parameter	+25°C	-40°C to +85°C	-40°C to +125°C	Unit	Test Conditions/Comments
Power Supplies Grounded	±8 ±5	±15	±50	nA max nA typ	$V_{DD} = 0\text{ V}$ , $V_{SS} = 0\text{ V}$ , $GND = 0\text{ V}$ , $V_S = \pm 55\text{ V}$ , $INx = 0\text{ V}$ , see <a href="#">Figure 31</a>
Power Supplies Floating	±100 ±50	±100 ±50	±100 ±50	nA max μA typ	$V_{DD} = \text{floating}$ , $V_{SS} = \text{floating}$ , $GND = 0\text{ V}$ , $V_S = \pm 55\text{ V}$ , $INx = 0\text{ V}$ , see <a href="#">Figure 31</a>
DIGITAL INPUTS/OUTPUTS					
Input Voltage					
High, $V_{INH}$			2.0	V min	
Low, $V_{INL}$			0.8	V max	
Input Current, $I_{INL}$ or $I_{INH}$	±0.7 ±1.1		±1.2	μA typ μA max	$V_{IN} = GND$ or $V_{DD}$
Digital Input Capacitance, $C_{IN}$	5.0			pF typ	
Output Voltage					
High, $V_{OH}$	2.0			V min	
Low, $V_{OL}$	0.4			V max	
DYNAMIC CHARACTERISTICS					
Transition Time, $t_{TRANSITION}$	140 170			ns typ ns max	$R_L = 1\text{ k}\Omega$ , $C_L = 35\text{ pF}$ $V_S = 8\text{ V}$ , see <a href="#">Figure 47</a>
$t_{ON}(\overline{EN})$	145 170	185	195	ns typ ns max	$R_L = 1\text{ k}\Omega$ , $C_L = 35\text{ pF}$ $V_S = 8\text{ V}$ , see <a href="#">Figure 46</a>
$t_{OFF}(\overline{EN})$	95 115	185 125	200 125	ns typ ns max	$R_L = 1\text{ k}\Omega$ , $C_L = 35\text{ pF}$ $V_S = 8\text{ V}$ , see <a href="#">Figure 46</a>
Break-Before-Make Time Delay, $t_D$	80		60	ns typ ns min	$R_L = 1\text{ k}\Omega$ , $C_L = 35\text{ pF}$ $V_S = 8\text{ V}$ , see <a href="#">Figure 45</a>
Overvoltage Response Time, $t_{RESPONSE}$	110 145		145	ns typ ns max	$R_L = 1\text{ k}\Omega$ , $C_L = 5\text{ pF}$ , see <a href="#">Figure 40</a>
Overvoltage Recovery Time, $t_{RECOVERY}$	500 655	145 720	145 765	ns typ ns max	$R_L = 1\text{ k}\Omega$ , $C_L = 5\text{ pF}$ , see <a href="#">Figure 41</a>
Interrupt Flag Response Time, $t_{DIGRESP}$	95			ns typ	$C_L = 12\text{ pF}$ , see <a href="#">Figure 42</a>
Interrupt Flag Recovery Time, $t_{DIGREC}$	65 900			μs typ ns typ	$C_L = 12\text{ pF}$ , see <a href="#">Figure 43</a> $C_L = 12\text{ pF}$ , $R_{PULLUP} = 1\text{ k}\Omega$ , see <a href="#">Figure 44</a>
Charge Injection, $Q_{INJ}$	0.8			pC typ	$V_S = 6\text{ V}$ , $R_S = 0\text{ }\Omega$ , $C_L = 1\text{ nF}$ , see <a href="#">Figure 48</a>
Off Isolation	-74			dB typ	$R_L = 50\text{ }\Omega$ , $C_L = 5\text{ pF}$ , $f = 1\text{ MHz}$ , see <a href="#">Figure 37</a>
Channel-to-Channel Crosstalk	-82			dB typ	$R_L = 50\text{ }\Omega$ , $C_L = 5\text{ pF}$ , $f = 1\text{ MHz}$ , see <a href="#">Figure 39</a>
Total Harmonic Distortion Plus Noise, THD + N	0.044			% typ	$R_L = 10\text{ k}\Omega$ , $V_S = 6\text{ V p-p}$ , $f = 20\text{ Hz to } 20\text{ kHz}$ , see <a href="#">Figure 36</a>
-3 dB Bandwidth	320			MHz typ	$R_L = 50\text{ }\Omega$ , $C_L = 5\text{ pF}$ , see <a href="#">Figure 38</a>
Insertion Loss	10.5			dB typ	$R_L = 50\text{ }\Omega$ , $C_L = 5\text{ pF}$ , $f = 1\text{ MHz}$ , see <a href="#">Figure 38</a>
$C_S$ (Off)	4			pF typ	$V_S = 6\text{ V}$ , $f = 1\text{ MHz}$
$C_D$ (Off)	5			pF typ	$V_S = 6\text{ V}$ , $f = 1\text{ MHz}$
$C_D$ (On), $C_S$ (On)	10			pF typ	$V_S = 6\text{ V}$ , $f = 1\text{ MHz}$
POWER REQUIREMENTS					
Normal Mode					$V_{DD} = \text{POSFV} = 13.2\text{ V}$ , $V_{SS} = \text{NEGFV} = 0\text{ V}$ , $GND = 0\text{ V}$ , digital inputs = 0 V, 5 V, or $V_{DD}$
$I_{DD}$	1.3			mA typ	
$I_{\text{POSFV}}$	0.15			mA typ	
$I_{DD} + I_{\text{POSFV}}$	2.15		2.25	mA max	

## SPECIFICATIONS

Table 3. (Continued)

Parameter	+25°C	-40°C to +85°C	-40°C to +125°C	Unit	Test Conditions/Comments
$I_{GND}$	0.75			mA typ	
	1.4		1.5	mA max	
$I_{SS}$	0.55			mA typ	
$I_{NEGFV}$	0.2			mA typ	
$I_{SS} + I_{NEGFV}$	0.95		1.0	mA max	
Fault Mode					$V_S = \pm 55\text{ V}$ , all channels in fault
$I_{DD}$	1.4			mA typ	
$I_{POSFV}$	0.2			mA typ	
$I_{DD} + I_{POSFV}$	2.5		2.8	mA max	
$I_{GND}$	0.9			mA typ	
	1.8		1.9	mA max	
$I_{SS}$	0.55			mA typ	Digital inputs = 5 V
$I_{NEGFV}$	0.2			mA typ	
$I_{SS} + I_{NEGFV}$	1.2		1.3	mA max	$V_S = \pm 55\text{ V}$ , $V_D = 0\text{ V}$
$V_{DD}/V_{SS}$			8	V min	GND = 0 V
			44	V max	GND = 0 V

## 36 V SINGLE SUPPLY

$V_{DD} = 36\text{ V} \pm 10\%$ ,  $V_{SS} = 0\text{ V}$ , GND = 0 V,  $C_{DECOUPLING} = 0.1\ \mu\text{F}$ , unless otherwise noted.

Table 4.

Parameter	+25°C	-40°C to +85°C	-40°C to +125°C	Unit	Test Conditions/Comments
ANALOG SWITCH					$V_{DD} = 32.4\text{ V}$ , $V_{SS} = 0\text{ V}$ , see <a href="#">Figure 35</a>
Analog Signal Range			0 V to $V_{DD}$	V	
On Resistance, $R_{ON}$	310			$\Omega$ typ	$V_S = 0\text{ V}$ to 30 V, $I_S = -1\text{ mA}$
	335	415	480	$\Omega$ max	
	250			$\Omega$ typ	$V_S = 4.5\text{ V}$ to 28 V, $I_S = -1\text{ mA}$
	270	335	395	$\Omega$ max	
On-Resistance Match Between Channels, $\Delta R_{ON}$	3			$\Omega$ typ	$V_S = 0\text{ V}$ to 30 V, $I_S = -1\text{ mA}$
	8	17	19	$\Omega$ max	
	3			$\Omega$ typ	$V_S = 4.5\text{ V}$ to 28 V, $I_S = -1\text{ mA}$
	8	12.5	13.5	$\Omega$ max	
On-Resistance Flatness, $R_{FLAT(ON)}$	62			$\Omega$ typ	$V_S = 0\text{ V}$ to 30 V, $I_S = -1\text{ mA}$
	70	85	100	$\Omega$ max	
	1.5			$\Omega$ typ	$V_S = 4.5\text{ V}$ to 28 V, $I_S = -1\text{ mA}$
	4.5	5	5	$\Omega$ max	
Threshold Voltage, $V_T$	0.7			V typ	See <a href="#">Figure 27</a>
LEAKAGE CURRENTS					$V_{DD} = 39.6\text{ V}$ , $V_{SS} = 0\text{ V}$
Source Off Leakage, $I_S$ (Off)	$\pm 0.1$			nA typ	$V_S = 1\text{ V}/30\text{ V}$ , $V_D = 30\text{ V}/1\text{ V}$ , see <a href="#">Figure 33</a>
	$\pm 1$	$\pm 2$	$\pm 5$	nA max	
Drain Off Leakage, $I_D$ (Off)	$\pm 0.1$			nA typ	$V_S = 1\text{ V}/30\text{ V}$ , $V_D = 30\text{ V}/1\text{ V}$ , see <a href="#">Figure 33</a>
	$\pm 1$	$\pm 2$	$\pm 5$	nA max	
Channel On Leakage, $I_D$ (On), $I_S$ (On)	$\pm 0.3$			nA typ	$V_S = V_D = 1\text{ V}/30\text{ V}$ , see <a href="#">Figure 34</a>
	$\pm 1.5$	$\pm 5$	$\pm 10$	nA max	
FAULT					
Source Leakage Current, $I_S$					

## SPECIFICATIONS

Table 4. (Continued)

Parameter	+25°C	-40°C to +85°C	-40°C to +125°C	Unit	Test Conditions/Comments
With Overvoltage	±58			μA typ	$V_{DD} = 39.6\text{ V}$ , $V_{SS} = 0\text{ V}$ , $GND = 0\text{ V}$ , $V_S = +55\text{ V}$ , $-40\text{ V}$ , see <a href="#">Figure 32</a>
Power Supplies Grounded or Floating	±25			μA typ	$V_{DD} = 0\text{ V}$ or floating, $V_{SS} = 0\text{ V}$ or floating, $GND = 0\text{ V}$ , $IN_x = 0\text{ V}$ or floating, $V_S = +55\text{ V}$ , $-40\text{ V}$ , see <a href="#">Figure 31</a>
Drain Leakage Current, $I_D$					
With Overvoltage	±2			nA typ	$V_{DD} = 39.6\text{ V}$ , $V_{SS} = 0\text{ V}$ , $GND = 0\text{ V}$ , $V_S = +55\text{ V}$ , $-40\text{ V}$ , see <a href="#">Figure 32</a>
Power Supplies Grounded	±8 ±5	±15	±50	nA max nA typ	$V_{DD} = 0\text{ V}$ , $V_{SS} = 0\text{ V}$ , $GND = 0\text{ V}$ , $V_S = +55\text{ V}$ , $-40\text{ V}$ , $IN_x = 0\text{ V}$ , see <a href="#">Figure 31</a>
Power Supplies Floating	±100 ±50	±100 ±50	±100 ±50	nA max μA typ	$V_{DD} = \text{floating}$ , $V_{SS} = \text{floating}$ , $GND = 0\text{ V}$ , $V_S = +55\text{ V}$ , $-40\text{ V}$ , $IN_x = 0\text{ V}$ , see <a href="#">Figure 31</a>
DIGITAL INPUTS/OUTPUTS					
Input Voltage					
High, $V_{INH}$			2.0	V min	
Low, $V_{INL}$			0.8	V max	
Input Current, $I_{INL}$ or $I_{INH}$	±0.7 ±1.1		±1.2	μA typ μA max	$V_{IN} = V_{GND}$ or $V_{DD}$
Digital Input Capacitance, $C_{IN}$	5.0			pF typ	
Output Voltage					
High, $V_{OH}$	2.0			V min	
Low, $V_{OL}$	0.4			V max	
DYNAMIC CHARACTERISTICS					
Transition Time, $t_{TRANSITION}$	155 190		210	ns typ ns max	$R_L = 1\text{ k}\Omega$ , $C_L = 35\text{ pF}$ $V_S = 18\text{ V}$ , see <a href="#">Figure 47</a>
$t_{ON}(\overline{EN})$	160 195	205	220	ns typ ns max	$R_L = 1\text{ k}\Omega$ , $C_L = 35\text{ pF}$ $V_S = 18\text{ V}$ , see <a href="#">Figure 46</a>
$t_{OFF}(\overline{EN})$	95 115	210 125	130	ns typ ns max	$R_L = 1\text{ k}\Omega$ , $C_L = 35\text{ pF}$ $V_S = 18\text{ V}$ , see <a href="#">Figure 46</a>
Break-Before-Make Time Delay, $t_D$	100			ns typ	$R_L = 1\text{ k}\Omega$ , $C_L = 35\text{ pF}$
Overvoltage Response Time, $t_{RESPONSE}$	60 80		70 85	ns typ ns max	$V_S = 18\text{ V}$ , see <a href="#">Figure 45</a> $R_L = 1\text{ k}\Omega$ , $C_L = 5\text{ pF}$ , see <a href="#">Figure 40</a>
Overvoltage Recovery Time, $t_{RECOVERY}$	1400 1900	85 2100	85 2200	ns typ ns max	$R_L = 1\text{ k}\Omega$ , $C_L = 5\text{ pF}$ , see <a href="#">Figure 41</a>
Interrupt Flag Response Time, $t_{DIGRESP}$	85			ns typ	$C_L = 12\text{ pF}$ , see <a href="#">Figure 42</a>
Interrupt Flag Recovery Time, $t_{DIGREC}$	65 1600			μs typ ns typ	$C_L = 12\text{ pF}$ , see <a href="#">Figure 43</a> $C_L = 12\text{ pF}$ , $R_{PULLUP} = 1\text{ k}\Omega$ , see <a href="#">Figure 44</a>
Charge Injection, $Q_{INJ}$	-1.4			pC typ	$V_S = 18\text{ V}$ , $R_S = 0\text{ }\Omega$ , $C_L = 1\text{ nF}$ , see <a href="#">Figure 48</a>
Off Isolation	-74			dB typ	$R_L = 50\text{ }\Omega$ , $C_L = 5\text{ pF}$ , $f = 1\text{ MHz}$ , see <a href="#">Figure 37</a>
Channel-to-Channel Crosstalk	-85			dB typ	$R_L = 50\text{ }\Omega$ , $C_L = 5\text{ pF}$ , $f = 1\text{ MHz}$ , see <a href="#">Figure 39</a>
Total Harmonic Distortion Plus Noise, THD + N	0.007			% typ	$R_L = 10\text{ k}\Omega$ , $V_S = 18\text{ V p-p}$ , $f = 20\text{ Hz}$ to $20\text{ kHz}$ , see <a href="#">Figure 36</a>
-3 dB Bandwidth	355			MHz typ	$R_L = 50\text{ }\Omega$ , $C_L = 5\text{ pF}$ , see <a href="#">Figure 38</a>
Insertion Loss	10.5			dB typ	$R_L = 50\text{ }\Omega$ , $C_L = 5\text{ pF}$ , $f = 1\text{ MHz}$ , see <a href="#">Figure 38</a>
$C_S$ (Off)	4			pF typ	$V_S = 18\text{ V}$ , $f = 1\text{ MHz}$
$C_D$ (Off)	4			pF typ	$V_S = 18\text{ V}$ , $f = 1\text{ MHz}$
$C_D$ (On), $C_S$ (On)	9			pF typ	$V_S = 18\text{ V}$ , $f = 1\text{ MHz}$

## SPECIFICATIONS

Table 4. (Continued)

Parameter	+25°C	-40°C to +85°C	-40°C to +125°C	Unit	Test Conditions/Comments	
<b>POWER REQUIREMENTS</b>						
Normal Mode						
$I_{DD}$	1.3			mA typ	$V_{DD} = \text{POSFV} = 39.6 \text{ V}$ , $V_{SS} = \text{NEGFV} = 0 \text{ V}$ , $\text{GND} = 0 \text{ V}$ , digital inputs = 0 V, 5 V, or $V_{DD}$	
$I_{\text{POSFV}}$	0.15			mA typ		
$I_{DD} + I_{\text{POSFV}}$	2.15		2.25	mA max		
$I_{\text{GND}}$	0.75			mA typ		
	1.4		1.5	mA max		
$I_{SS}$	0.55			mA typ		
$I_{\text{NEGFV}}$	0.2			mA typ		
$I_{SS} + I_{\text{NEGFV}}$	0.95		1.0	mA max		
Fault Mode						
$I_{DD}$	1.4			mA typ		$V_S = +55 \text{ V}$ , $-40 \text{ V}$ , all channels in fault
$I_{\text{POSFV}}$	0.2			mA typ		
$I_{DD} + I_{\text{POSFV}}$	2.5		2.8	mA max		
$I_{\text{GND}}$	0.9			mA typ		
	1.8		1.9	mA max		
$I_{SS}$	0.55			mA typ		
$I_{\text{NEGFV}}$	0.2			mA typ		
$I_{SS} + I_{\text{NEGFV}}$	1.2		1.3	mA max		
$V_{DD}/V_{SS}$			8	V min	$\text{GND} = 0 \text{ V}$	
			44	V max	$\text{GND} = 0 \text{ V}$	

## CONTINUOUS CURRENT PER CHANNEL, SX OR DX

Sx is the S1A to S3A and S1B to S3B pins.

Table 5.

Parameter	25°C	85°C	125°C	Unit	Test Conditions/Comments
20-LEAD TSSOP					
$\theta_{JA} = 112.6^\circ\text{C/W}$	17	11	7	mA max	$V_S = V_{SS} \text{ to } V_{DD} - 4.5 \text{ V}$
	10	7	5	mA max	$V_S = V_{SS} \text{ to } V_{DD}$
20-LEAD LFCSP					
$\theta_{JA} = 30.4^\circ\text{C/W}$	29	18	9	mA max	$V_S = V_{SS} \text{ to } V_{DD} - 4.5 \text{ V}$
	17	11	7	mA max	$V_S = V_{SS} \text{ to } V_{DD}$

## ABSOLUTE MAXIMUM RATINGS

$T_A = 25^\circ\text{C}$ , unless otherwise noted.

Table 6.

Parameter	Rating
$V_{DD}$ to $V_{SS}$	48 V
$V_{DD}$ to GND	-0.3 V to +48 V
$V_{SS}$ to GND	-48 V to +0.3 V
POSFV to GND	-0.3 V to $V_{DD} + 0.3$ V
NEGFV to GND	$V_{SS} - 0.3$ V to +0.3 V
Sx Pins	-55 V to +55 V
Sx to $V_{DD}$ or $V_{SS}$	80 V
$V_S$ to $V_D$	80 V
Dx Pins <sup>1</sup>	NEGFV - 0.7 V to POSFV + 0.7 V or 30 mA, whichever occurs first
Digital Inputs	GND - 0.7 V to 48 V or 30 mA, whichever occurs first
Peak Current, Sx or Dx Pins	44.5 mA (pulsed at 1 ms, 10% duty cycle maximum)
Continuous Current, Sx or Dx Pins	Data <sup>2</sup> + 15%
Digital Outputs	GND - 0.7 V to 6 V or 30 mA, whichever occurs first
Dx Pins, Overvoltage State, Load Current	1 mA
Operating Temperature Range	-40°C to +125°C
Storage Temperature Range	-65°C to +150°C
Junction Temperature	150°C
Thermal Impedance, $\theta_{JA}$	
20-Lead TSSOP, Thermal Impedance (4-Layer Board)	112.6°C/W
20-Lead LFCSP, Thermal Impedance (4-Layer Board)	30.4°C/W
Reflow Soldering Peak Temperature, Pb-Free	As per JEDEC J-STD-020

<sup>1</sup> Overvoltages at the Dx pins are clamped by internal diodes. Limit the current to the maximum ratings given.

<sup>2</sup> See Table 5.

Stresses at or above those listed under Absolute Maximum Ratings cause permanent damage to the product. This is a stress rating only; functional operation of the product at these or any other conditions above those indicated in the operational section of this specification is not implied. Operation beyond the maximum operating conditions for extended periods may affect product reliability.

Only one absolute maximum rating can be applied at any one time.

## ESD CAUTION



**ESD (electrostatic discharge) sensitive device.** Charged devices and circuit boards can discharge without detection. Although this product features patented or proprietary protection circuitry, damage may occur on devices subjected to high energy ESD. Therefore, proper ESD precautions should be taken to avoid performance degradation or loss of functionality.

PIN CONFIGURATIONS AND FUNCTION DESCRIPTIONS

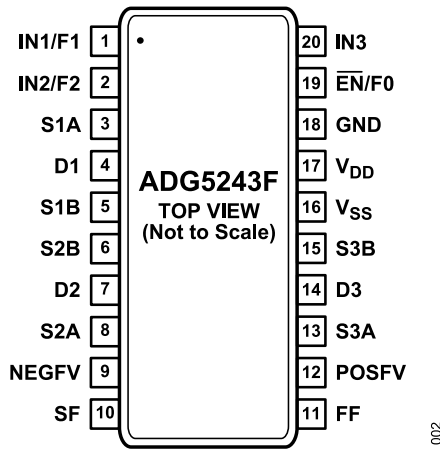

Figure 2. ADG5243F Pin Configuration (TSSOP)

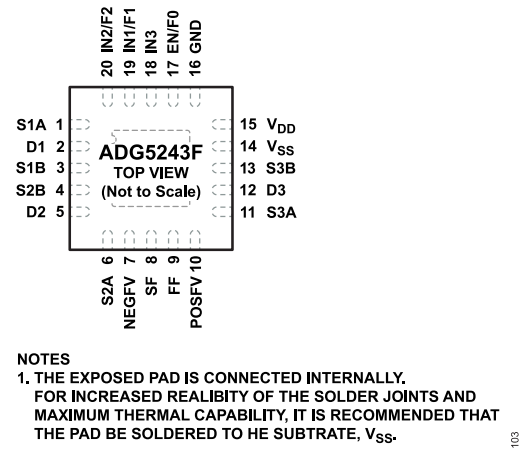

Figure 3. ADG5243F Pin Configuration (LFCSP)

Table 7. Pin Function Descriptions

Pin No.		Mnemonic	Description
TSSOP	LFCSP		
1	19	IN1/F1	Logic Control Input (IN1) (See Table 8.) Decoder Pin (F1). This pin is used together with the specific fault pin (SF) to indicate which input is in a fault condition (see Table 9).
2	20	IN2/F2	Logic Control Input (IN2) (See Table 8.) Decoder Pin (F2). This pin is used together with the specific fault pin (SF) to indicate which input is in a fault condition (see Table 9).
3	1	S1A	Overvoltage Protected Source Terminal 1A. This pin can be an input or an output.
4	2	D1	Drain Terminal 1. This pin can be an input or an output.
5	3	S1B	Overvoltage Protected Source Terminal 1B. This pin can be an input or an output.
6	4	S2B	Overvoltage Protected Source Terminal 2B. This pin can be an input or an output.
7	5	D2	Drain Terminal 2. This pin can be an input or an output.
8	6	S2A	Overvoltage Protected Source Terminal 2A. This pin can be an input or an output.
9	7	NEGFV	Negative Fault Voltage. This pin is the negative supply voltage that determines the overvoltage protection level. If a secondary supply is not used, connect this pin to V <sub>SS</sub> .
10	8	SF	Specific Fault Digital Output. This pin has a high output when the device is in normal operation or a low output when a fault condition is detected on a specific pin, depending on the state of F0, F1, and F2 as shown in Table 9. The SF pin has a weak internal pull-up resistor, nominally 3 V output.
11	9	FF	Fault Flag Digital Output. This pin has a high output when the device is in normal operation, or a low output when a fault condition occurs on any of the Sx inputs. The FF pin has a weak internal pull-up resistor that allows multiple signals to be combined into a single interrupt for larger modules that contain multiple devices.
12	10	POSFV	Positive Fault Voltage. This pin is the positive supply voltage that determines the overvoltage protection level. If a secondary supply is not used, connect this pin to V <sub>DD</sub> .
13	11	S3A	Overvoltage Protected Source Terminal 3A. This pin can be an input or an output.
14	12	D3	Drain Terminal 3. This pin can be an input or an output.
15	13	S3B	Overvoltage Protected Source Terminal 3B. This pin can be an input or an output.
16	14	V <sub>SS</sub>	Most Negative Power Supply Potential.
17	15	V <sub>DD</sub>	Most Positive Power Supply Potential.
18	16	GND	Ground (0 V) Reference.
19	17	EN/F0	Active Low Digital Input. When this pin is high, the device is disabled and all switches are off. When this pin is low, the INx logic inputs determine the on switches. Decoder Pin (F0). This pin is used together with the specific fault pin (SF) to indicate which input is in a fault condition (see Table 9).
20	18	IN3	Logic Control Input (See Table 8.)

## PIN CONFIGURATIONS AND FUNCTION DESCRIPTIONS

Table 7. Pin Function Descriptions (Continued)

Pin No.			
TSSOP	LFCSP	Mnemonic	Description
	Exposed Pad	EP	The exposed pad is connected internally. For increased reliability of the solder joints and maximum thermal capability, it is recommended that the pad be soldered to the substrate, $V_{SS}$ .

Table 8. Switch Selection Truth Table

EN	INx	SxA	SxB
1	X <sup>1</sup>	Off	Off
0	0	Off	On
0	1	On	Off

<sup>1</sup> X means don't care.

Table 9. Fault Diagnostic Output Truth Table

Switch in Fault <sup>1</sup>	State of Specific Flag (SF) with Control Inputs (F2, F1, F0)						State of Fault Flag (FF)
	0, 0, 0	0, 1, 0	1, 0, 0	1, 0, 1	1, 1, 0	1, 1, 1	
None	1	1	1	1	1	1	1
S1A	0	1	1	1	1	1	0
S1B	1	0	1	1	1	1	0
S2B	1	1	0	1	1	1	0
S2A	1	1	1	1	0	1	0
S3B	1	1	1	0	1	1	0
S3A	1	1	1	1	1	0	0

<sup>1</sup> More than one switch can be in fault. See the [Applications Information](#) section for more information.

TYPICAL PERFORMANCE CHARACTERISTICS

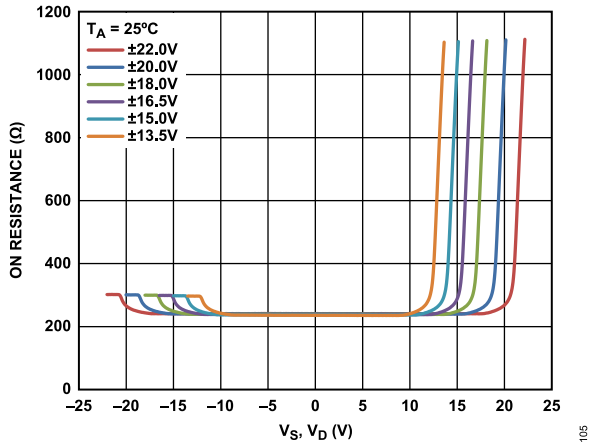

Figure 4.  $R_{ON}$  as a Function of  $V_S, V_D$ , Dual Supply

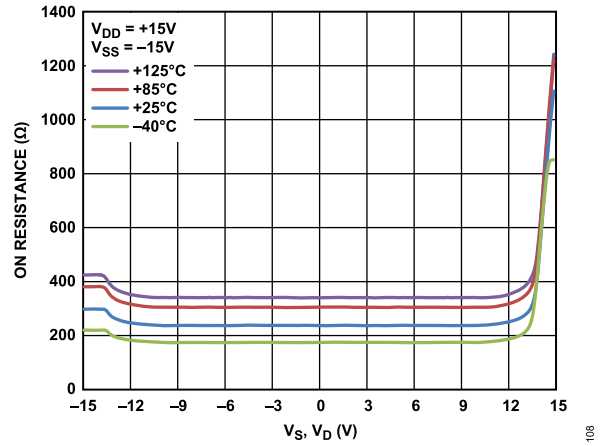

Figure 7.  $R_{ON}$  as a Function of  $V_S, V_D$  for Different Temperatures,  $\pm 15\text{ V}$  Dual Supply

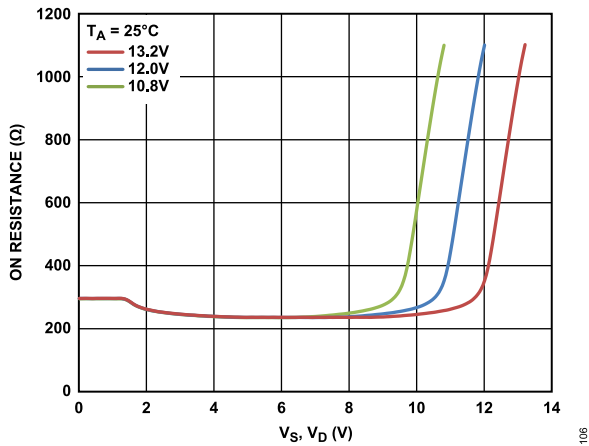

Figure 5.  $R_{ON}$  as a Function of  $V_S, V_D$ , 12 V Single Supply

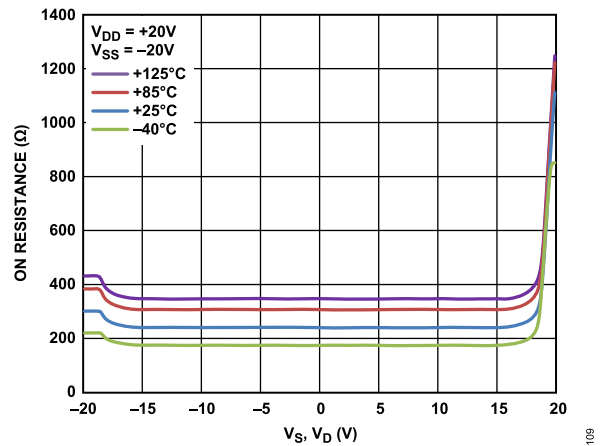

Figure 8.  $R_{ON}$  as a Function of  $V_S, V_D$  for Different Temperatures,  $\pm 20\text{ V}$  Dual Supply

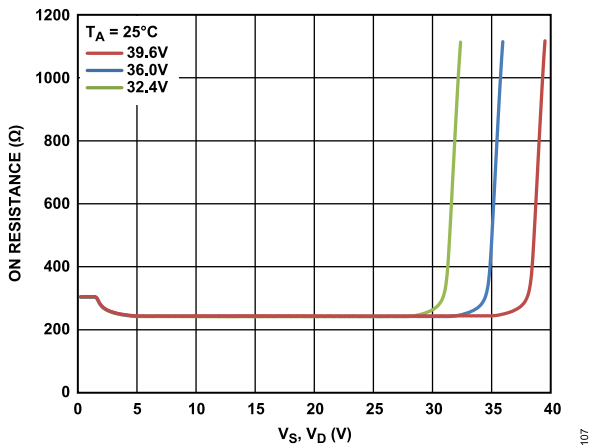

Figure 6.  $R_{ON}$  as a Function of  $V_S, V_D$ , 36 V Single Supply

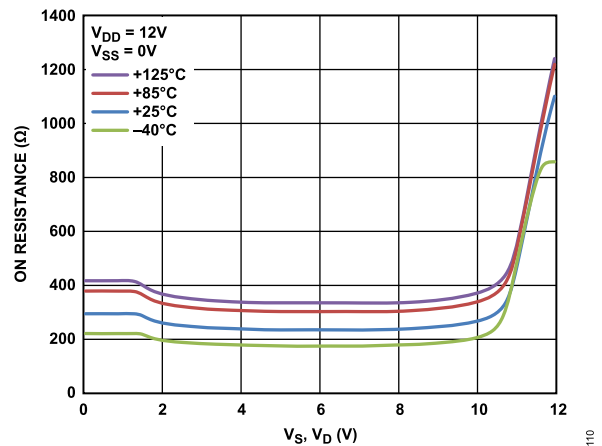

Figure 9.  $R_{ON}$  as a Function of  $V_S, V_D$  for Different Temperatures, 12 V Single Supply

TYPICAL PERFORMANCE CHARACTERISTICS

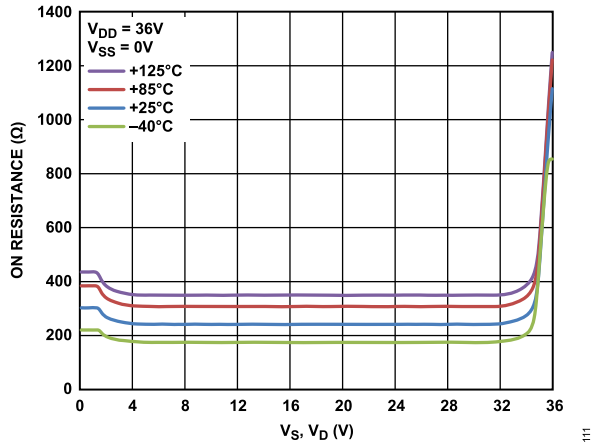

Figure 10.  $R_{ON}$  as a Function of  $V_S$ ,  $V_D$  for Different Temperatures, 36 V Single Supply

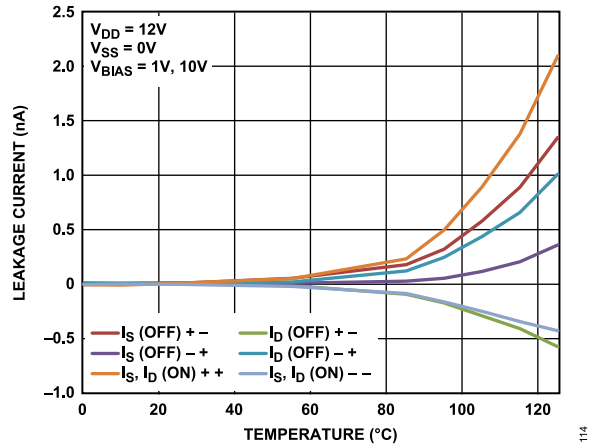

Figure 13. Leakage Current vs. Temperature, 12 V Single Supply

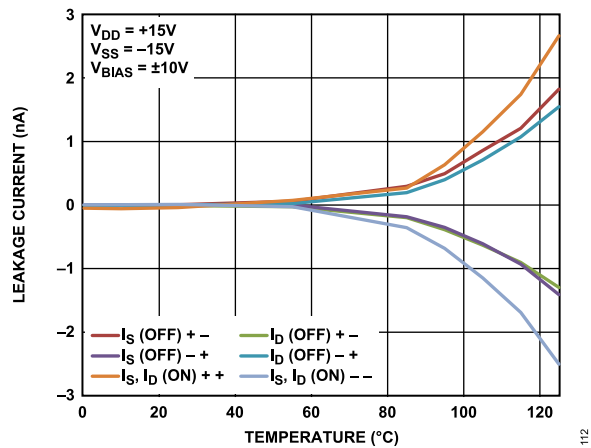

Figure 11. Leakage Current vs. Temperature, ±15 V Dual Supply

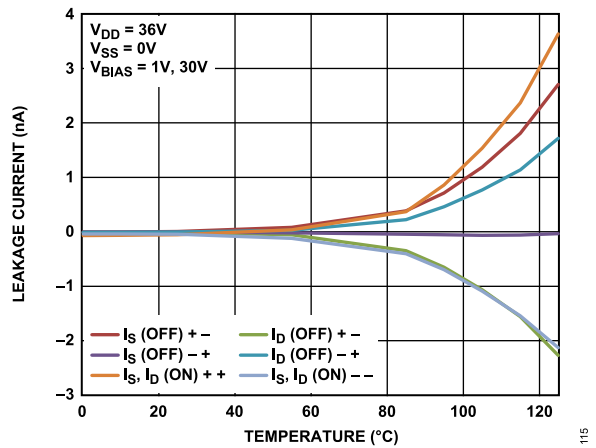

Figure 14. Leakage Current vs. Temperature, 36 V Single Supply

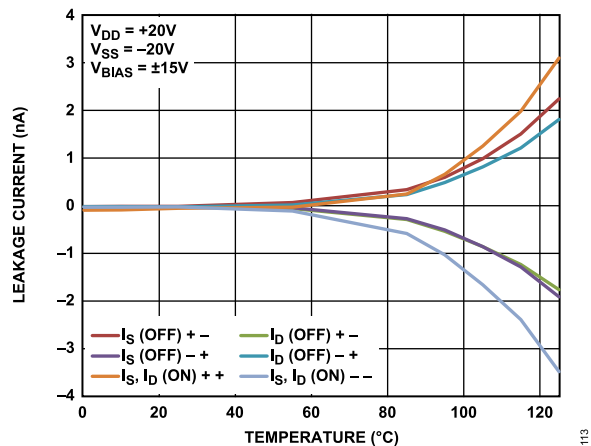

Figure 12. Leakage Current vs. Temperature, ±20 V Dual Supply

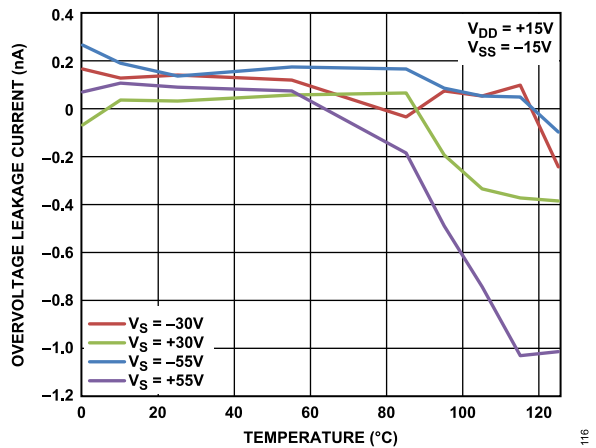

Figure 15. Overvoltage Leakage Current vs. Temperature, ±15 V Dual Supply

TYPICAL PERFORMANCE CHARACTERISTICS

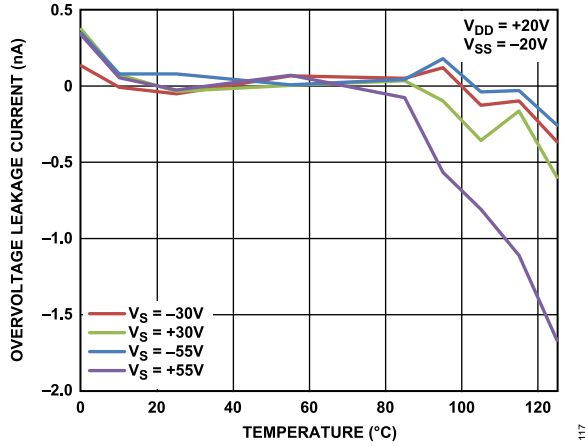

Figure 16. Overvoltage Leakage Current vs. Temperature, ±20 V Dual Supply

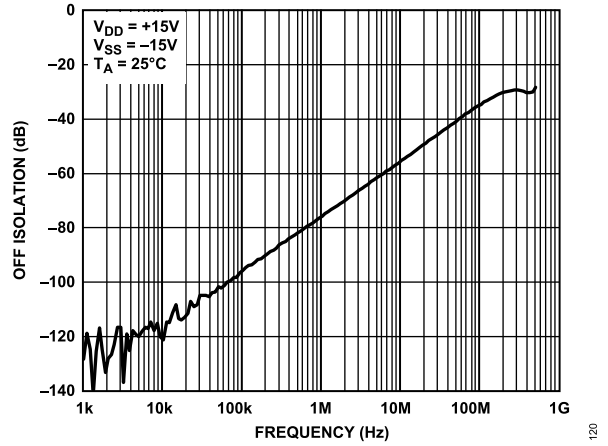

Figure 19. Off Isolation vs. Frequency, ±15 V Dual Supply

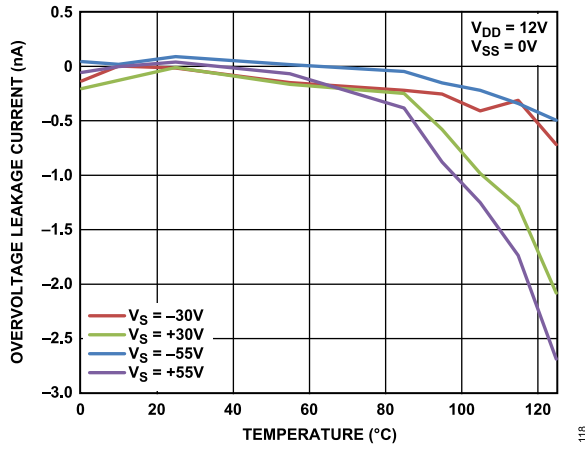

Figure 17. Overvoltage Leakage Current vs. Temperature, 12 V Single Supply

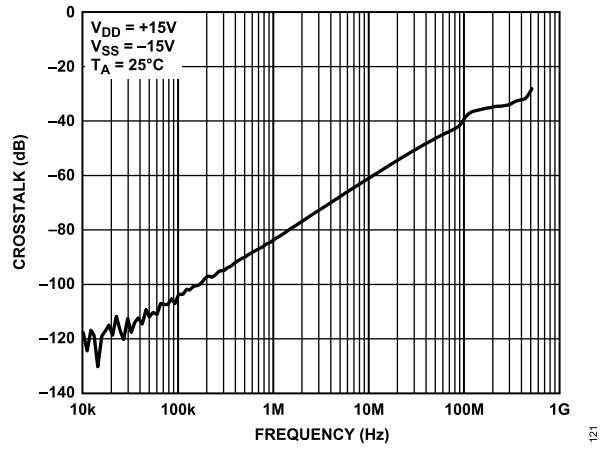

Figure 20. Crosstalk vs. Frequency, ±15 V Dual Supply

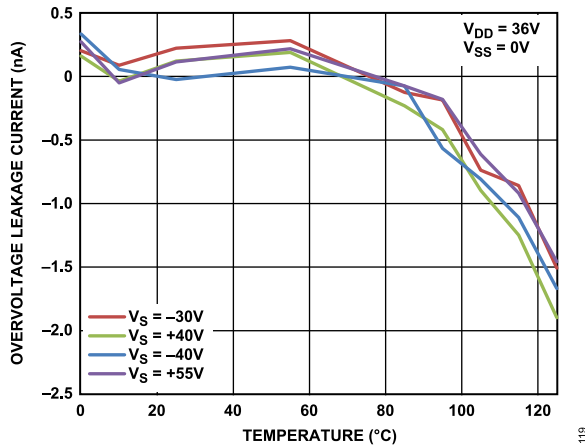

Figure 18. Overvoltage Leakage Current vs. Temperature, 36 V Single Supply

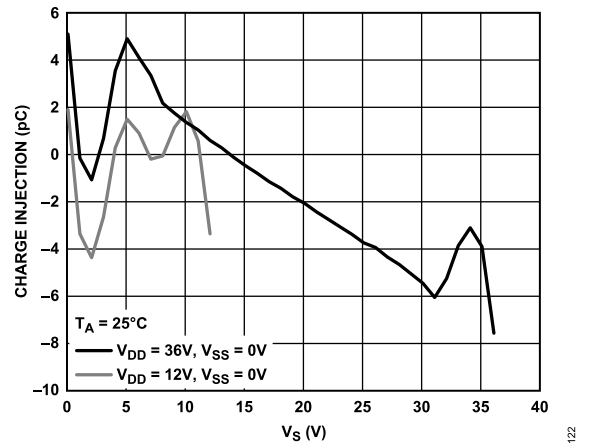

Figure 21. Charge Injection vs. Source Voltage (VS), Single Supply

TYPICAL PERFORMANCE CHARACTERISTICS

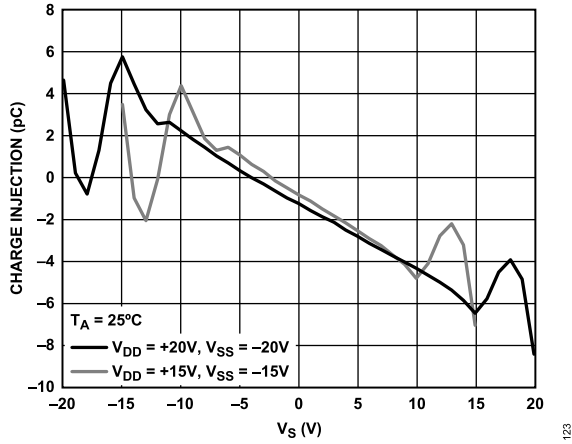

Figure 22. Charge Injection vs. Source Voltage ( $V_S$ ), Dual Supply

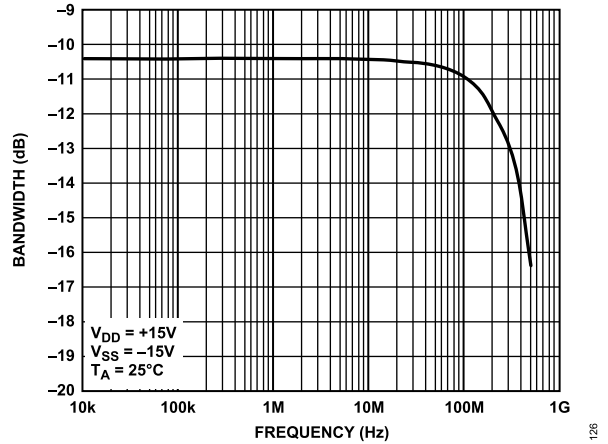

Figure 25. Bandwidth vs. Frequency

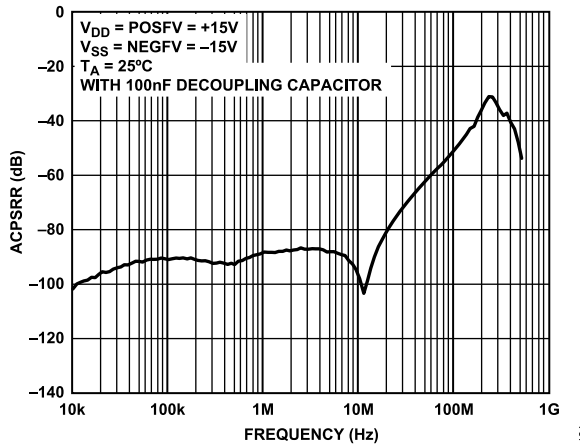

Figure 23. ACPSRR vs. Frequency,  $\pm 15$  V Dual Supply

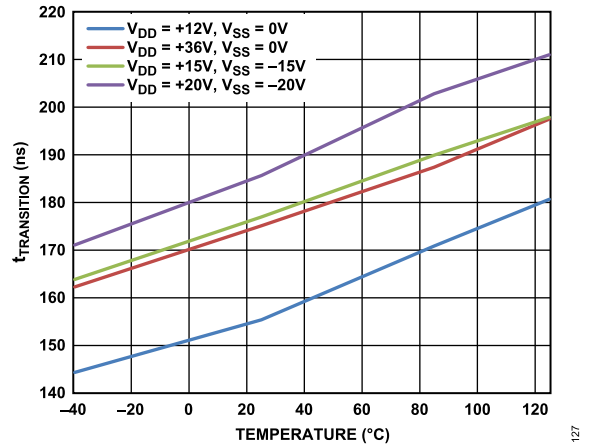

Figure 26.  $t_{\text{TRANSITION}}$  vs. Temperature

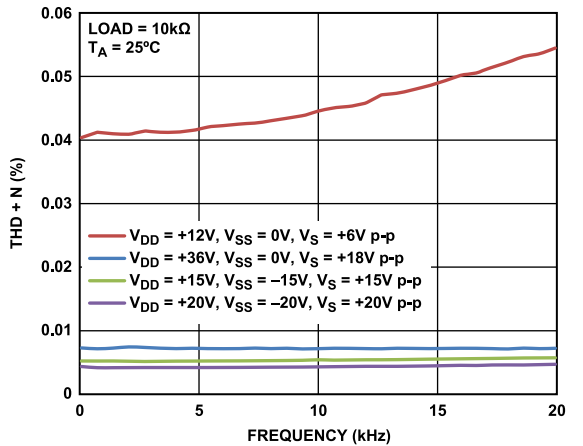

Figure 24. THD + N vs. Frequency

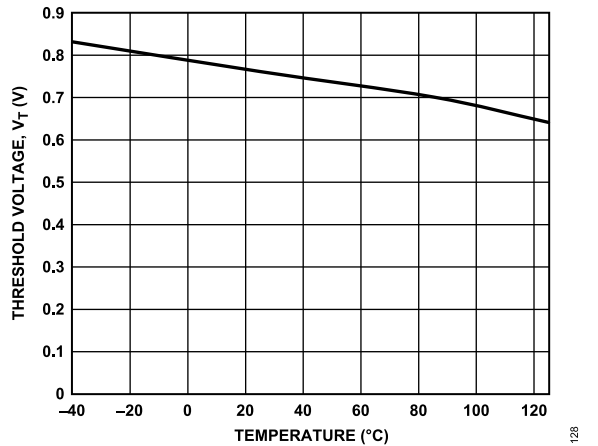

Figure 27. Threshold Voltage ( $V_T$ ) vs. Temperature

TYPICAL PERFORMANCE CHARACTERISTICS

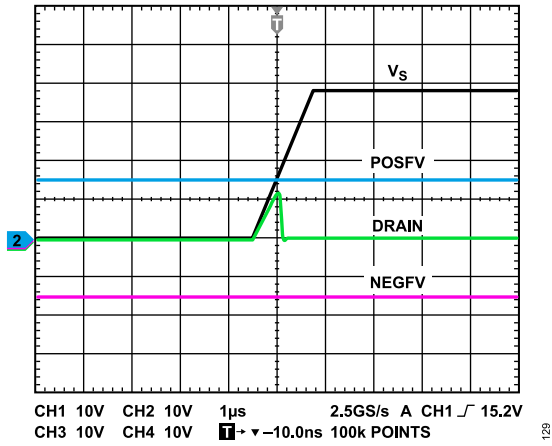

Figure 28. Drain Output Response to Positive Overvoltage ( $R_L = 1\text{ k}\Omega$ )

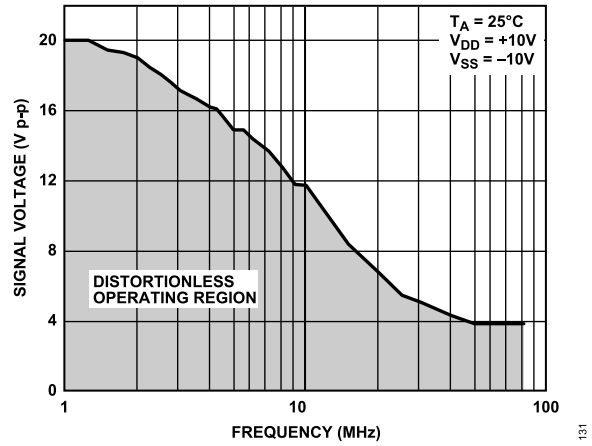

Figure 30. Large Signal Voltage Tracking vs. Frequency

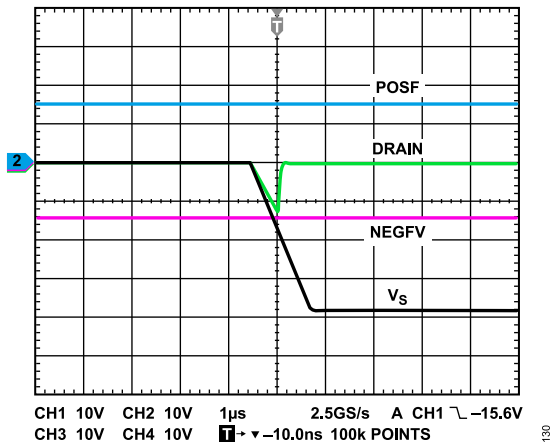

Figure 29. Drain Output Response to Negative Overvoltage ( $R_L = 1\text{ k}\Omega$ )

TEST CIRCUITS

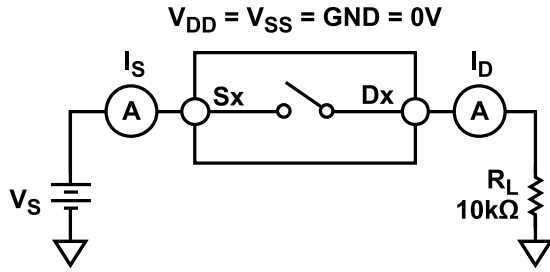

Figure 31. Switch Unpowered Leakage

030

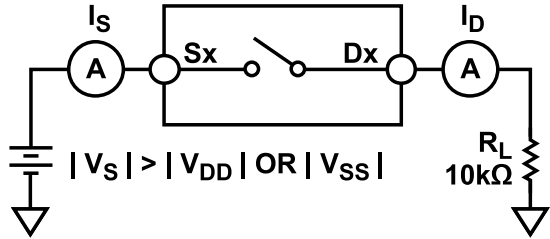

Figure 32. Switch Overvoltage Leakage

031

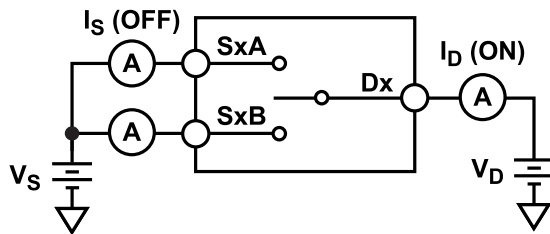

Figure 33. Off Leakage

032

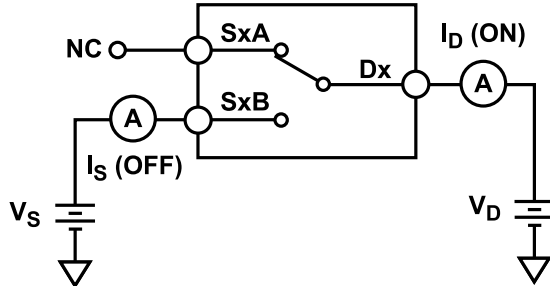

Figure 34. On Leakage

033

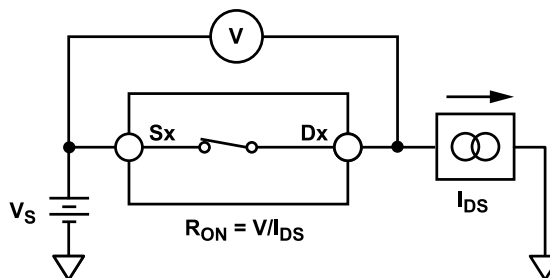

Figure 35. On Resistance

034

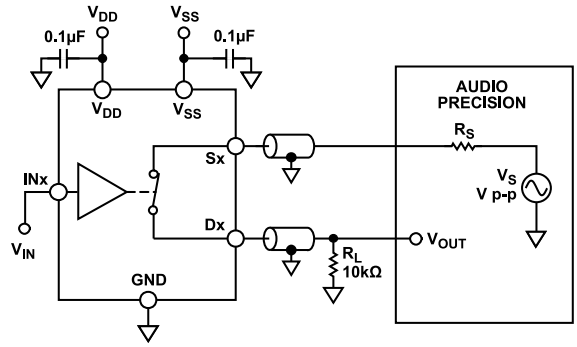
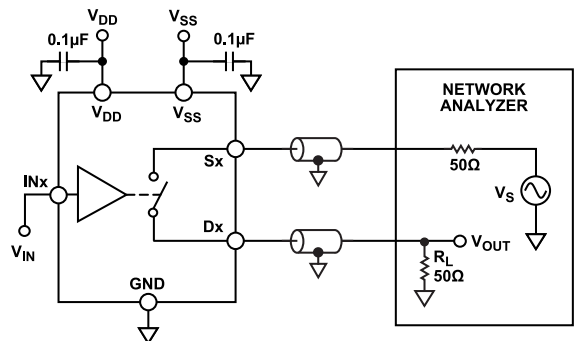

Figure 36. THD + N

035



$$\text{OFF ISOLATION} = 20 \log \frac{V_{\text{OUT}}}{V_S}$$

Figure 37. Off Isolation

036

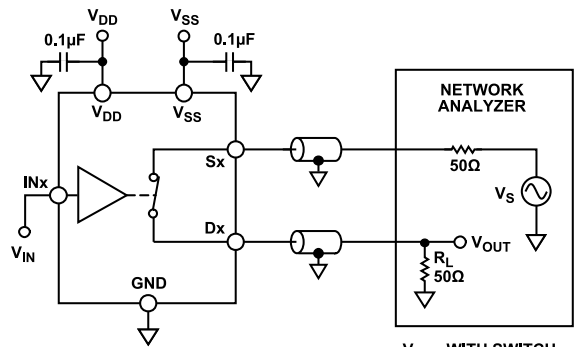

$$\text{INSERTION LOSS} = 20 \log \frac{V_{\text{OUT WITH SWITCH}}}{V_{\text{OUT WITHOUT SWITCH}}}$$

Figure 38. Bandwidth

037

TEST CIRCUITS

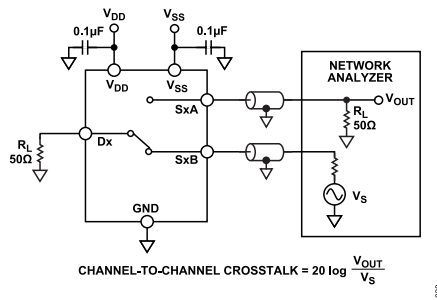

Figure 39. Channel-to-Channel Crosstalk

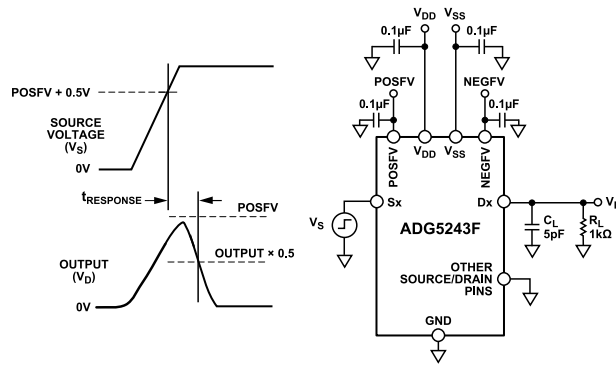
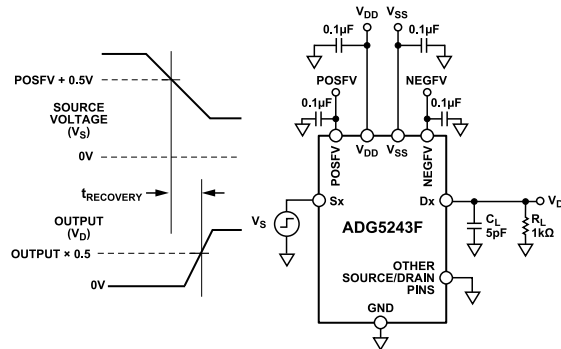

Figure 40. Overvoltage Response Time,  $t_{RESPONSE}$



NOTES  
 1. THE OUTPUT STARTS FROM THE POSFV CLAMP LEVEL WITHOUT A 1KΩ RESISTOR (INTERNAL 40kΩ PULL-UP RESISTOR TO THE POSFV SUPPLY RAIL DURING A FAULT).

Figure 41. Overvoltage Recovery Time,  $t_{RECOVERY}$

TEST CIRCUITS

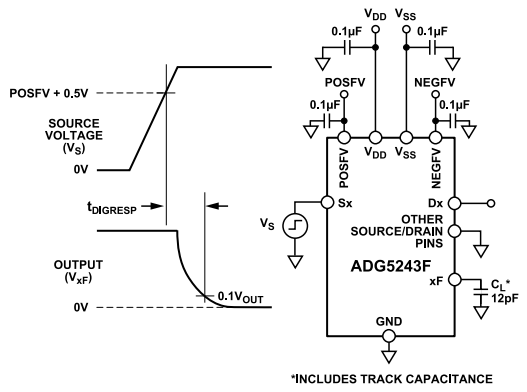

Figure 42. Interrupt Flag Response Time,  $t_{DIGRESP}$

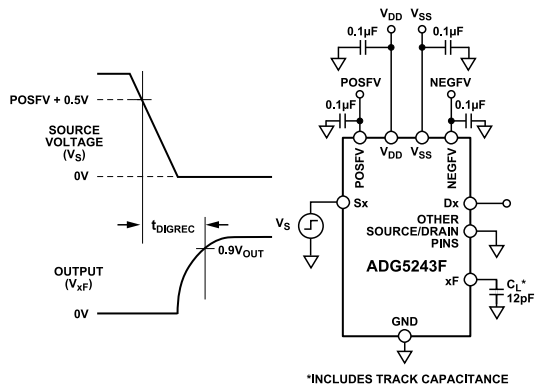

Figure 43. Interrupt Flag Recovery Time,  $t_{DIGREC}$

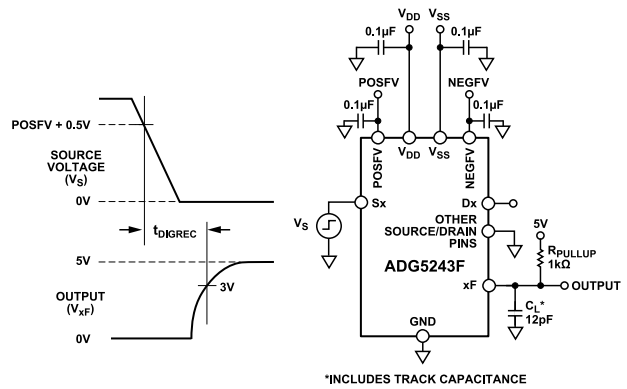

Figure 44. Interrupt Flag Recovery Time,  $t_{DIGREC}$ , with a 1 kΩ Pull-Up Resistor

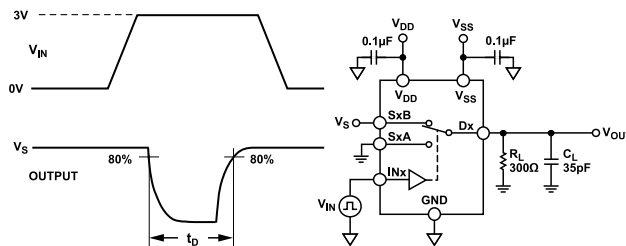

Figure 45. Break-Before-Make Time Delay,  $t_D$

TEST CIRCUITS

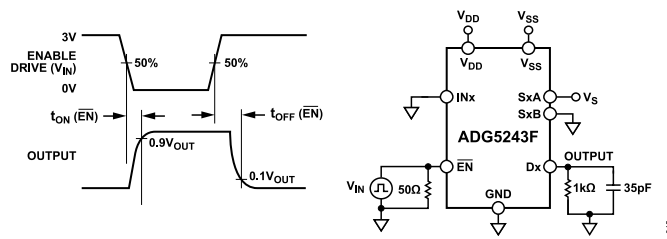

Figure 46. Enable Delay,  $t_{ON}(\overline{EN})$ ,  $t_{OFF}(\overline{EN})$

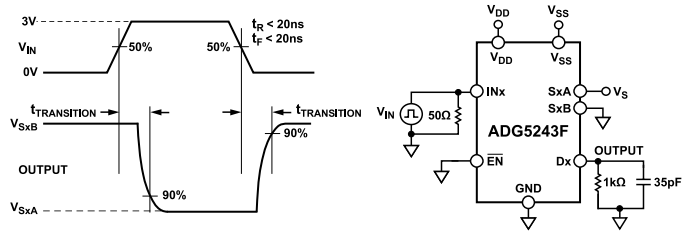

Figure 47. Digital Control Input to Output Switching Time,  $t_{TRANSITION}$

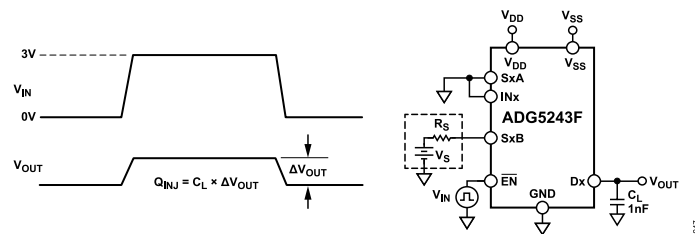

Figure 48. Charge Injection,  $Q_{INJ}$

## TERMINOLOGY

**I<sub>DD</sub>**

I<sub>DD</sub> represents the positive supply current.

**I<sub>SS</sub>**

I<sub>SS</sub> represents the negative supply current.

**I<sub>POSFV</sub>**

I<sub>POSFV</sub> represents the positive secondary supply current.

**I<sub>NEGFV</sub>**

I<sub>NEGFV</sub> represents the negative secondary supply current.

**V<sub>D</sub>**

V<sub>D</sub> represents the analog voltage on the Dx pins.

**V<sub>S</sub>**

V<sub>S</sub> represents the analog voltage on the Sx pins.

**R<sub>ON</sub>**

R<sub>ON</sub> represents the ohmic resistance between the Dx pins and the Sx pins.

**ΔR<sub>ON</sub>**

ΔR<sub>ON</sub> represents the difference between the R<sub>ON</sub> of any two channels.

**R<sub>FLAT(ON)</sub>**

R<sub>FLAT(ON)</sub> is the flatness that is defined as the difference between the maximum and minimum value of on resistance measured over the specified analog signal range.

**I<sub>S</sub> (Off)**

I<sub>S</sub> (off) is the source leakage current with the switch off.

**I<sub>D</sub> (Off)**

I<sub>D</sub> (off) is the drain leakage current with the switch off.

**I<sub>D</sub> (On), I<sub>S</sub> (On)**

I<sub>D</sub> (on) and I<sub>S</sub> (on) represent the channel leakage currents with the switch on.

**V<sub>INL</sub>**

V<sub>INL</sub> is the maximum input voltage for Logic 0.

**V<sub>INH</sub>**

V<sub>INH</sub> is the minimum input voltage for Logic 1.

**I<sub>INL</sub>, I<sub>INH</sub>**

I<sub>INL</sub> and I<sub>INH</sub> represent the low and high input currents of the digital inputs.

**C<sub>D</sub> (Off)**

C<sub>D</sub> (off) represents the off switch drain capacitance, which is measured with reference to ground.

**C<sub>S</sub> (Off)**

C<sub>S</sub> (off) represents the off switch source capacitance, which is measured with reference to ground.

**C<sub>D</sub> (On), C<sub>S</sub> (On)**

C<sub>D</sub> (on) and C<sub>S</sub> (on) represent the on switch capacitances, which are measured with reference to ground.

**C<sub>IN</sub>**

C<sub>IN</sub> is the digital input capacitance.

**t<sub>ON</sub> (EN)**

t<sub>ON</sub> (EN) represents the delay between applying the digital control input and the output switching on (see Figure 46).

**t<sub>OFF</sub> (EN)**

t<sub>OFF</sub> (EN) represents the delay between applying the digital control input and the output switching off (see Figure 46).

**t<sub>TRANSITION</sub>**

t<sub>TRANSITION</sub> represents the delay time between the 50% and 90% points of the digital inputs and the switch on condition when switching from one switch state to another.

**t<sub>D</sub>**

t<sub>D</sub> represents the off time measured between the 80% points of both switches when switching from one state to another.

**t<sub>DIGRESP</sub>**

t<sub>DIGRESP</sub> is the time required for the FF pin to go low (0.3 V), measured with respect to the voltage on the source pin exceeding the supply voltage by 0.5 V.

**t<sub>DIGREC</sub>**

t<sub>DIGREC</sub> is the time required for the FF pin to return high, measured with respect to the voltage on the Sx pin falling below the supply voltage plus 0.5 V.

**t<sub>RESPONSE</sub>**

t<sub>RESPONSE</sub> represents the delay between the source voltage exceeding the supply voltage by 0.5 V and the drain voltage falling to 90% of the supply voltage.

**t<sub>RESPONSE</sub>(EN)**

t<sub>RESPONSE</sub> (EN) represents the delay between the enable pin being asserted and the drain reaching 90% of POSFV or NEGFV for a switch that is in fault.

**TERMINOLOGY** **$t_{\text{RECOVERY}}$** 

$t_{\text{RECOVERY}}$  represents the delay between an overvoltage on a Sx pin falling below the supply voltage plus 0.5 V and the drain voltage rising from 0 V to 10% of the supply voltage.

**Off Isolation**

Off isolation is a measure of unwanted signal coupling through an off switch.

**Charge Injection**

Charge injection is a measure of the glitch impulse transferred from the digital input to the analog output during switching.

**Channel to Channel Crosstalk**

Channel to channel crosstalk is a measure of unwanted signal that is coupled through from one channel to another as a result of parasitic capacitance.

**Insertion Loss**

Insertion loss is the loss due to the on resistance of the switch.

**-3 dB Bandwidth**

-3 dB bandwidth is the frequency at which the output is attenuated by 3 dB.

**AC Power Supply Rejection Ratio (ACPSRR)**

ACPSRR is the ratio of the amplitude of signal on the output to the amplitude of the modulation. ACPSRR is a measure of the ability of the device to avoid coupling noise and spurious signals that appear on the supply voltage pin to the output of the switch. The dc voltage on the device is modulated by a sine wave of 0.62 V p-p.

**On Response**

On response is the frequency response of the on switch.

 **$V_T$** 

$V_T$  is the voltage threshold at which the overvoltage protection circuitry engages (see [Figure 27](#)).

**Total Harmonic Distortion Plus Noise (THD + N)**

THD + N is the ratio of the harmonic amplitude plus noise of the signal to the fundamental.

## THEORY OF OPERATION

### SWITCH ARCHITECTURE

Each channel of the ADG5243F consists of a parallel pair of N-channel diffused metal-oxide semiconductor (NDMOS) and P-channel DMOS (PDMOS) transistors. This construction provides excellent performance across the signal range. The ADG5243F channels operate as standard switches when input signals with a voltage between POSFV and NEGFV are applied. For example, the on resistance is 250  $\Omega$  typically and opening or closing the switch is controlled using the appropriate control pins.

Additional internal circuitry enables the switch to detect overvoltage inputs by comparing the voltage on a source pin with POSFV and NEGFV. A signal is considered overvoltage if it exceeds these secondary supply voltages by the voltage threshold,  $V_T$ . The threshold voltage is typically 0.7 V, but can range from 0.8 V at  $-40^\circ\text{C}$  down to 0.6 V at  $+125^\circ\text{C}$ . See Figure 27 to see the change in  $V_T$  with operating temperature.

The maximum voltage that can be applied to any source input is +55 V or  $-55$  V. When the device is powered using a single supply of 25 V or greater, the maximum negative signal level is reduced. It reduces from  $-55$  V at  $V_{DD} = +25$  V to  $-40$  V at  $V_{DD} = +40$  V to remain within the 80 V maximum rating. Construction of the process allows the channel to withstand 80 V across the switch when it is opened. These overvoltage limits apply whether the power supplies are present or not.

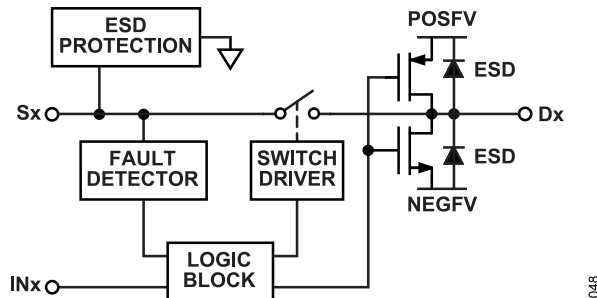

Figure 49. Switch Channel and Control Function

When an overvoltage condition is detected on a source pin ( $S_x$ ), the switch automatically opens regardless of the digital logic state and the source pin becomes high impedance. If a source pin is selected that is in fault, the drain pin is pulled to the supply that was exceeded. For example, if the source voltage exceeds POSFV, the drain output pulls to POSFV. If the source voltage exceeds NEGFV, the drain output pulls to NEGFV. In Figure 28, the voltage on the drain pin can be seen to follow the voltage on the source pin until the switch turns off completely. The drain pin then pulls to GND due to the 1 k $\Omega$  load resistor; otherwise, it pulls to the POSFV supply. The maximum voltage on the drain is limited by the internal ESD diodes and the rate at which the output voltage discharges is dependent on the load at the pin.

During overvoltage conditions, the leakage current into and out of the source pins is limited to tens of microamperes. If the source

pin is unselected, only nanoamperes of leakage appear on the drain pin. However, if the source is selected, the pin is pulled to the supply rail. The device that pulls the drain pin to the rail has an impedance of approximately 40 k $\Omega$ ; thus, the  $D_x$  pin current is limited to approximately 1 mA during a shorted load condition. This internal impedance also determines the minimum external load resistance required to ensure that the drain pin is pulled to the desired voltage level during a fault.

When an overvoltage event occurs, the channels undisturbed by the overvoltage input continue to operate normally without additional crosstalk.

### ESD Performance

The drain pins have ESD protection diodes to the secondary supply rails and the voltage at these pins must not exceed the secondary supply voltages, POSFV and NEGFV. The source pins have specialized ESD protection that allows the signal voltage to reach  $\pm 55$  V regardless of supply voltage level. Exceeding  $\pm 55$  V on any source input can damage the ESD protection circuitry on the device. See Figure 49 for an overview of the switch channel.

### Trench Isolation

In the ADG5243F, an insulating oxide layer (trench) is placed between the NDMOS and the PDMOS transistors of each switch. Parasitic junctions, which occur between the transistors in junction-isolated switches, are eliminated, and the result is a switch that is latch-up immune under all circumstances. The device passes a JESD78D latch-up test of  $\pm 500$  mA for 1 sec, which is the harshest test in the specification.

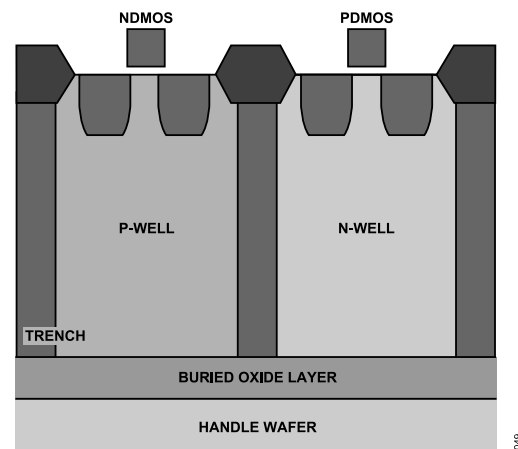

Figure 50. Trench Isolation

### USER DEFINED FAULT PROTECTION

POSFV and NEGFV are required secondary power supplies that set the level at which the overvoltage protection is engaged. POSFV can be supplied from 4.5 V to  $V_{DD}$ , and NEGFV can be supplied from  $V_{SS}$  to 0 V. If a secondary supply is not available, connect these pins to  $V_{DD}$  (POSFV) and  $V_{SS}$  (NEGFV). The over-

## THEORY OF OPERATION

voltage protection then engages at the primary supply voltages. When the voltages at the source inputs exceed POSFV or NEGFV by  $V_T$ , the switch turns off or, if the device is unpowered, the switch remains off. The switch input remains high impedance regardless of the digital input state and if it is selected, the drain pulls to either POSFV or NEGFV. Signal levels up to +55 V and -55 V are blocked in both the powered and unpowered condition as long as the 80 V limitation between the source and supply pins is met.

### Power-On Protection

The following conditions must be satisfied for the switch to be in the on condition:

- ▶ The primary supply must be  $V_{DD}$  to  $V_{SS} \geq 8$  V.
- ▶ For POSFV, the secondary supply must be between 4.5 V and  $V_{DD}$ , and for NEGFV, the secondary supply must be between  $V_{SS}$  and 0 V.
- ▶ The input signal must be between  $NEGFV - V_T$  and  $POSFV + V_T$ .
- ▶ The digital logic control input has selected the switch.

When the switch is turned on, signal levels up to the secondary supply rails are passed.

The switch responds to an analog input that exceeds POSFV or NEGFV by a threshold voltage,  $V_T$ , by turning off. The absolute input voltage limits are -55 V and +55 V, while maintaining an 80 V limit between the source pin and the supply rails. The switch remains off until the voltage at the source pin returns to between POSFV and NEGFV.

The fault response time ( $t_{RESPONSE}$ ) when powered by  $\pm 15$  V dual supply is typically 90 ns and the fault recovery time ( $t_{RECOVERY}$ ) is 745 ns. These vary with supply voltages and output load conditions.

The maximum stress across the switch channel is 80 V, therefore, the user must pay close attention to this limit under a fault condition.

For example, consider the case where the device is set up in a multiplexer configuration as shown in [Figure 51](#).

- ▶  $V_{DD}/V_{SS}$  and POSFV/NEGFV =  $\pm 22$  V, S1A = S2B = +22 V, S1B = +55 V, and S2A = -55 V.
- ▶ S1A and S2A are selected.
- ▶ The voltage between S1B and D1 =  $+55$  V - (22 V) = +33 V.
- ▶ The voltage between S2B and D2 =  $+22$  V - (-55 V) = +77 V.

These calculations are all within device specifications: a 55 V maximum fault on the source inputs and a maximum of 80 V across the off switch channel.

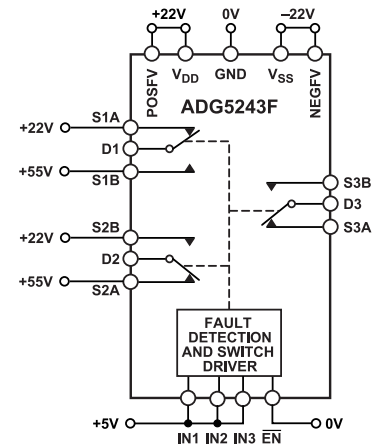

Figure 51. ADG5243F in an Overvoltage Condition

### Power-Off Protection

When no power supplies are present, the switch remains in the off condition, and the switch inputs are high impedance. This state ensures that no current flows and prevents damage to the switch or downstream circuitry. The switch output is a virtual open circuit.

The switch remains off regardless of whether the  $V_{DD}$  and  $V_{SS}$  supplies are 0 V or floating. A GND reference must always be present to ensure proper operation. Signal levels of up to  $\pm 55$  V are blocked in the unpowered condition.

### Digital Input Protection

The ADG5243F can tolerate digital input signals being present on the device without power. When the device is unpowered, the switch is guaranteed to be in the off state, regardless of the state of the digital logic signals.

The digital inputs are protected against positive faults of up to 44 V. The digital inputs do not offer protection against negative overvoltages. ESD protection diodes connected to GND are present on the digital inputs.

### Overvoltage Interrupt Flag

The voltages on the source inputs of the ADG5243F are continuously monitored, and the state of the switches is indicated by an active low digital output pin, FF.

The voltage on the FF pin indicates if any of the source input pins are experiencing a fault condition. The output of the FF pin is a nominal 3 V when all source pins are within normal operating range. If any source pin voltage exceeds the secondary supply voltage by  $V_T$ , the FF output reduces to below 0.4 V.

Use the specific fault digital output pin, SF, to decode which inputs are experiencing a fault condition. The SF pin reduces to below 0.4 V when a fault condition is detected on a specific pin, depending on the state of F0, F1, and F2 (see [Table 9](#)).

## APPLICATIONS INFORMATION

The overvoltage protected family of switches and multiplexers provides robust solutions for instrumentation, industrial, automotive, aerospace, and other harsh environments where overvoltage signals can be present and the system must remain operational both during and after the overvoltage has occurred.

### POWER SUPPLY RAILS

To guarantee correct operation of the device, 0.1  $\mu\text{F}$  decoupling capacitors are required on the primary and secondary supplies. If they are driven from the same supply, one set of 0.1  $\mu\text{F}$  decoupling capacitors is sufficient.

The secondary supplies (POSFV and NEGFV) provide the current required to operate the fault protection and, thus, must be low impedance supplies. Therefore, they can be derived from the primary supplies by using a resistor divider and buffer.

The secondary supply rails (POSFV and NEGFV) must not exceed the primary supply rails ( $V_{\text{DD}}$  and  $V_{\text{SS}}$ ) because this can lead to a signal passing through the switch unintentionally.

The ADG5243F can operate with bipolar supplies between  $\pm 5\text{ V}$  and  $\pm 22\text{ V}$ . The supplies on  $V_{\text{DD}}$  and  $V_{\text{SS}}$  need not be symmetrical, but the  $V_{\text{DD}}$  to  $V_{\text{SS}}$  range must not exceed 44 V. The ADG5243F can also operate with single supplies between 8 V and 44 V with  $V_{\text{SS}}$  connected to GND.

The ADG5243F device is fully specified at  $\pm 15\text{ V}$ ,  $\pm 20\text{ V}$ ,  $+12\text{ V}$ , and  $+36\text{ V}$  supply ranges.

### POWER SUPPLY SEQUENCING PROTECTION

The switch channel remains open when the device is unpowered and signals from  $-55\text{ V}$  to  $+55\text{ V}$  can be applied without damaging the device. The switch channel closes only when the supplies are connected, a suitable digital control signal is placed on the control pins, and the signal is within normal operating range. Placing the ADG5243F between external connectors and sensitive components offers protection in systems where a signal is presented to the source pins before the supply voltages are available.

### SIGNAL RANGE

The primary supplies define the on-resistance profile of the channel, whereas the secondary supplies define the signal range. Using voltages on POSFV and NEGFV that are lower than  $V_{\text{DD}}$  and  $V_{\text{SS}}$ , the required signal can benefit from the flat on resistance in the center of the full signal capabilities of the device.

### POWER SUPPLY RECOMMENDATIONS

Analog Devices, Inc., has a wide range of power management products to meet the requirements of most high performance signal chains.

An example of a bipolar power solution is shown in [Figure 52](#). The [ADP7118](#) and [ADP7182](#) can be used to generate clean positive and negative rails from the [ADP5070](#) dual switching regulator out-

put. These rails can be used to power the ADG5243F, an amplifier, and/or a precision converter in a typical signal chain.

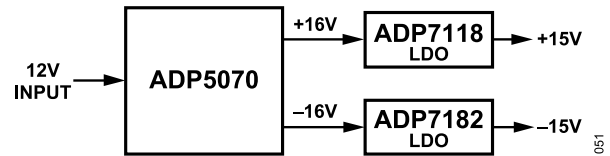

Figure 52. Bipolar Power Solution

Table 10. Recommended Power Management Devices

Product	Description
<a href="#">ADP5070</a>	1 A/0.6 A, dc-to-dc switching regulator with independent positive and negative outputs
<a href="#">ADP7118</a>	20 V, 200 mA, low noise, CMOS LDO
<a href="#">ADP7142</a>	40 V, 200 mA, low noise, CMOS LDO
<a href="#">ADP7182</a>	-28 V, -200 mA, low noise, linear regulator

## HIGH VOLTAGE SURGE SUPPRESSION

The ADG5243F is not intended for use in very high voltage applications. The maximum operating voltage of the transistor is 80 V. In applications where the inputs are likely to be subject to overvoltages exceeding the breakdown voltage, use transient voltage suppressors (TVSs) or similar.

## INTELLIGENT FAULT DETECTION

The ADG5243F digital output pin, FF, can interface with a microprocessor or control system and can be used as an interrupt flag. This feature provides real-time diagnostic information on the state of the device and the system to which it connects.

The control system can use the digital interrupt, FF, to start a variety of actions, as follows:

- ▶ Initiating an investigation into the source of an overvoltage fault.
- ▶ Shutting down critical systems in response to the overvoltage condition.
- ▶ Using data recorders to mark data during these events as unreliable or out of specification.

For systems that are sensitive during a start-up sequence, the active low operation of the flag allows the system to ensure that the ADG5243F is powered on and that all input voltages are within the normal operating range before initiating operation.

The FF pin has a weak internal pull-up resistor, which allows the signals to combine into a single interrupt for larger modules that contain multiple devices.

The recovery time,  $t_{\text{DIGREC}}$ , can be decreased from a typical 65  $\mu\text{s}$  to 900 ns by using a 1 k $\Omega$  pull-up resistor.

The specific fault digital output, SF decodes which inputs are experiencing a fault condition. The SF pin reduces to below 0.4 V when a fault condition is detected on a specific pin, depending on the state of the F0, F1, and F2 pins (see [Table 9](#)).

**APPLICATIONS INFORMATION****LARGE VOLTAGE, HIGH FREQUENCY SIGNALS**

Figure 30 illustrates the voltage range and frequencies that the ADG5243F can reliably convey. For signals that extend across the full signal range from  $V_{SS}$  to  $V_{DD}$ , keep the frequency below 1 MHz. If the required frequency is greater than 1 MHz, decrease the signal range appropriately to ensure signal integrity.

OUTLINE DIMENSIONS

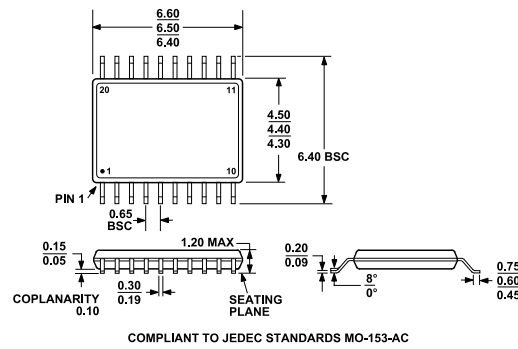

Figure 53. 20-Lead Thin Shrink Small Outline Package [TSSOP] (RU-20)  
Dimensions shown in millimeters

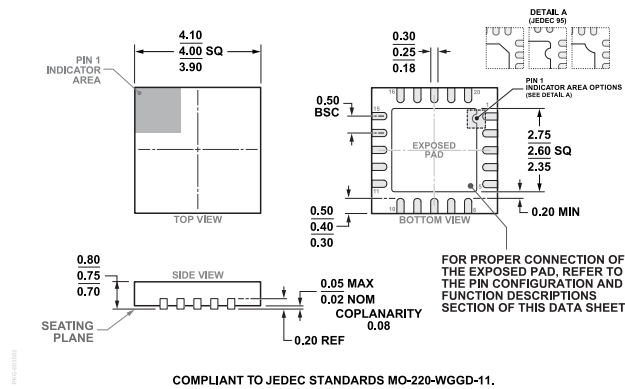

Figure 54. 20-Lead, Lead Frame Chip Scale Package [LFCSPP] 4 mm x 4 mm Body and 0.75 mm Package Height (CP-20-8)  
Dimensions shown in millimeters

Updated: October 25, 2022

ORDERING GUIDE

Model <sup>1</sup>	Temperature Range	Package Description	Packing Quantity	Package Option
ADG5243FBPZ-RL7	-40°C to +125°C	20-Lead LFCSP (4mm x 4mm w/ EP)	Reel, 1500	CP-20-8
ADG5243FBRUZ	-40°C to +125°C	20-Lead TSSOP		RU-20
ADG5243FBRUZ-RL7	-40°C to +125°C	20-Lead TSSOP	Reel, 1000	RU-20

<sup>1</sup> Z = RoHS Compliant Part.

EVALUATION BOARDS

Model <sup>1</sup>	Description
EVAL-ADG5243FEBZ	Evaluation Board

<sup>1</sup> Z = RoHS Compliant Part.

## Looking for pricing, stock, or lifecycle information?

Click below to explore more details on WIN SOURCE:

- ⊖ [View ADG5243FBRUZ-RL7 on WIN SOURCE](#)
- ⊖ [Analog Devices Inc. Information](#)

## Optimize Your Supply Chain with WIN SOURCE Solutions

- ✓ Global Sourcing Solution
- ✓ Obsolete Management
- ✓ Cost Control Management
- ✓ Shortage Management
- ✓ Alternative Solution
- ✓ Excess Inventory Management