



**THE DATASHEET OF
ADG786BCPZ**



ADG786/ADG788

FEATURES

- 1.8 V to 5.5 V Single Supply
- ± 2.5 V Dual Supply
- 2.5 Ω On Resistance
- 0.5 Ω On Resistance Flatness
- 100 pA Leakage Currents
- 19 ns Switching Times
- Triple SPDT: ADG786
- Quad SPDT: ADG788
- 20-Lead 4 mm \times 4 mm Chip Scale Packages
- Low Power Consumption
- TTL/CMOS-Compatible Inputs
- For Functionally-Equivalent Devices in 16-Lead TSSOP Packages, See ADG733/ADG734
- Qualified for automotive applications

APPLICATIONS

- Data Acquisition Systems
- Communication Systems
- Relay Replacement
- Audio and Video Switching
- Battery-Powered Systems

GENERAL DESCRIPTION

The ADG786 and ADG788 are low voltage, CMOS devices comprising three independently selectable SPDT (single pole, double throw) switches and four independently selectable SPDT switches respectively.

Low power consumption and operating supply range of 1.8 V to 5.5 V and dual ± 2.5 V make the ADG786 and ADG788 ideal for battery powered, portable instruments and many other applications. All channels exhibit break-before-make switching action preventing momentary shorting when switching channels. An $\overline{\text{EN}}$ input on the ADG786 is used to enable or disable the device. When disabled, all channels are switched OFF.

These multiplexers are designed on an enhanced submicron process that provides low power dissipation yet gives high switching speed, very low on resistance, high signal bandwidths and low leakage currents. On resistance is in the region of a few ohms, is closely matched between switches and very flat over the full signal range. These parts can operate equally well in either direction and have an input signal range which extends to the supplies.

The ADG786 and ADG788 are available in small 20-lead chip scale packages.

FUNCTIONAL BLOCK DIAGRAMS

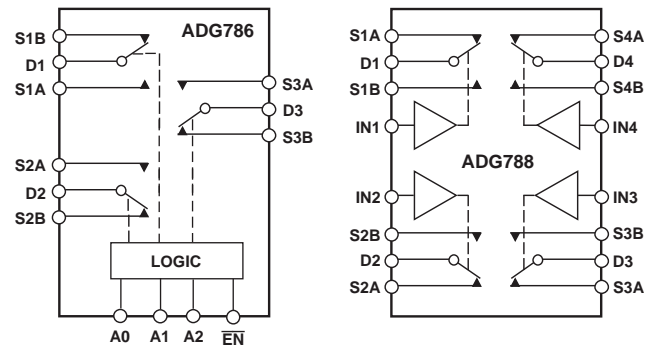

SWITCHES SHOWN FOR A LOGIC "1" INPUT

PRODUCT HIGHLIGHTS

1. Small 20-Lead 4 mm \times 4 mm Chip Scale Packages (CSP).
2. Single/Dual Supply Operation. The ADG786 and ADG788 are fully specified and guaranteed with 3 V \pm 10% and 5 V \pm 10% single supply rails, and ± 2.5 V \pm 10% dual supply rails.
3. Low On Resistance (2.5 Ω typical).
4. Low Power Consumption (< 0.01 μ W).
5. Guaranteed Break-Before-Make Switching Action.

ADG786/ADG788—SPECIFICATIONS¹ ($V_{DD} = 5\text{ V} \pm 10\%$, $V_{SS} = 0\text{ V}$, $GND = 0\text{ V}$, unless otherwise noted.)

Parameter	B Version		Unit	Test Conditions/Comments
	+25°C	-40°C to +85°C		
ANALOG SWITCH				
Analogue Signal Range		0 V to V_{DD}	V	
On Resistance (R_{ON})	2.5		Ω typ	$V_S = 0\text{ V}$ to V_{DD} , $I_{DS} = 10\text{ mA}$; Test Circuit 1
	4.5	5.0	Ω max	
On-Resistance Match between Channels (ΔR_{ON})		0.1	Ω typ	$V_S = 0\text{ V}$ to V_{DD} , $I_{DS} = 10\text{ mA}$
		0.4	Ω max	
On-Resistance Flatness ($R_{FLAT(ON)}$)	0.5		Ω typ	$V_S = 0\text{ V}$ to V_{DD} , $I_{DS} = 10\text{ mA}$
		1.2	Ω max	
LEAKAGE CURRENTS				
Source OFF Leakage I_S (OFF)	± 0.01		nA typ	$V_{DD} = 5.5\text{ V}$ $V_D = 4.5\text{ V}/1\text{ V}$, $V_S = 1\text{ V}/4.5\text{ V}$; Test Circuit 2
	± 0.1	± 0.3	nA max	
Channel ON Leakage I_D , I_S (ON)	± 0.01		nA typ	$V_D = V_S = 1\text{ V}$, or 4.5 V ; Test Circuit 3
	± 0.1	± 0.5	nA max	
DIGITAL INPUTS				
Input High Voltage, V_{INH}		2.4	V min	
Input Low Voltage, V_{INL}		0.8	V max	
Input Current				
I_{INL} or I_{INH}	0.005		μA typ	$V_{IN} = V_{INL}$ or V_{INH}
		± 0.1	μA max	
C_{IN} , Digital Input Capacitance	4		pF typ	
DYNAMIC CHARACTERISTICS²				
t_{ON}	19		ns typ	$R_L = 300\ \Omega$, $C_L = 35\text{ pF}$; $V_{S1A} = 3\text{ V}$, $V_{S1B} = 0\text{ V}$, Test Circuit 4
		34	ns max	
t_{OFF}	7		ns typ	$R_L = 300\ \Omega$, $C_L = 35\text{ pF}$; $V_S = 3\text{ V}$, Test Circuit 4
		12	ns max	
ADG786 $t_{ON}(\overline{EN})$	20		ns typ	$R_L = 300\ \Omega$, $C_L = 35\text{ pF}$; $V_S = 3\text{ V}$, Test Circuit 5
		40	ns max	
$t_{OFF}(\overline{EN})$	7		ns typ	$R_L = 300\ \Omega$, $C_L = 35\text{ pF}$; $V_S = 3\text{ V}$, Test Circuit 5
		12	ns max	
Break-Before-Make Time Delay, t_D	13		ns typ	$R_L = 300\ \Omega$, $C_L = 35\text{ pF}$; $V_S = 3\text{ V}$, Test Circuit 6
		1	ns min	
Charge Injection	± 3		pC typ	$V_S = 2\text{ V}$, $R_S = 0\ \Omega$, $C_L = 1\text{ nF}$; Test Circuit 7
Off Isolation	-80		dB typ	$R_L = 50\ \Omega$, $C_L = 5\text{ pF}$, $f = 1\text{ MHz}$; Test Circuit 8
Channel-to-Channel Crosstalk	-80		dB typ	$R_L = 50\ \Omega$, $C_L = 5\text{ pF}$, $f = 1\text{ MHz}$; Test Circuit 9
-3 dB Bandwidth	160		MHz typ	$R_L = 50\ \Omega$, $C_L = 5\text{ pF}$, Test Circuit 10
C_S (OFF)	11		pF typ	$f = 1\text{ MHz}$
C_D , C_S (ON)	34		pF typ	$f = 1\text{ MHz}$
POWER REQUIREMENTS				
I_{DD}	0.001		μA typ	$V_{DD} = 5.5\text{ V}$ Digital Inputs = 0 V or 5.5 V
		1.0	μA max	

NOTES

¹Temperature range is as follows: B Version: -40°C to +85°C.

²Guaranteed by design, not subject to production test.

Specifications subject to change without notice.

SPECIFICATIONS¹

($V_{DD} = 3\text{ V} \pm 10\%$, $V_{SS} = 0\text{ V}$, $GND = 0\text{ V}$, unless otherwise noted.)

Parameter	B Version		Unit	Test Conditions/Comments
	+25°C	-40°C to +85°C		
ANALOG SWITCH				
Analog Signal Range		0 V to V_{DD}	V	
On Resistance (R_{ON})	6		Ω typ	$V_S = 0\text{ V}$ to V_{DD} , $I_{DS} = 10\text{ mA}$; Test Circuit 1
	11	12	Ω max	
On-Resistance Match between Channels (ΔR_{ON})		0.1	Ω typ	$V_S = 0\text{ V}$ to V_{DD} , $I_{DS} = 10\text{ mA}$
		0.5	Ω max	
On-Resistance Flatness ($R_{FLAT(ON)}$)		3	Ω typ	$V_S = 0\text{ V}$ to V_{DD} , $I_{DS} = 10\text{ mA}$
LEAKAGE CURRENTS				
Source OFF Leakage I_S (OFF)	± 0.01		nA typ	$V_{DD} = 3.3\text{ V}$; $V_S = 3\text{ V}/1\text{ V}$, $V_D = 1\text{ V}/3\text{ V}$; Test Circuit 2
	± 0.1	± 0.3	nA max	
Channel ON Leakage I_D , I_S (ON)	± 0.01		nA typ	$V_S = V_D = 1\text{ V}$ or 3 V ; Test Circuit 3
	± 0.1	± 0.5	nA max	
DIGITAL INPUTS				
Input High Voltage, V_{INH}		2.0	V min	
Input Low Voltage, V_{INL}		0.8	V max	
Input Current I_{INL} or I_{INH}	0.005		μA typ	$V_{IN} = V_{INL}$ or V_{INH}
		± 0.1	μA max	
C_{IN} , Digital Input Capacitance	4		pF typ	
DYNAMIC CHARACTERISTICS²				
t_{ON}	28		ns typ	$R_L = 300\ \Omega$, $C_L = 35\text{ pF}$; $V_{S1A} = 2\text{ V}$, $V_{S1B} = 0\text{ V}$, Test Circuit 4
		55	ns max	
t_{OFF}	9		ns typ	$R_L = 300\ \Omega$, $C_L = 35\text{ pF}$; $V_S = 2\text{ V}$, Test Circuit 4
		16	ns max	
ADG786 $t_{ON}(\overline{EN})$	29		ns typ	$R_L = 300\ \Omega$, $C_L = 35\text{ pF}$; $V_S = 2\text{ V}$, Test Circuit 5
		60	ns max	
$t_{OFF}(\overline{EN})$	9		ns typ	$R_L = 300\ \Omega$, $C_L = 35\text{ pF}$; $V_S = 2\text{ V}$, Test Circuit 5
		16	ns max	
Break-Before-Make Time Delay, t_D	22		ns typ	$R_L = 300\ \Omega$, $C_L = 35\text{ pF}$; $V_S = 2\text{ V}$, Test Circuit 6
		1	ns min	
Charge Injection	± 3		pC typ	$V_S = 1\text{ V}$, $R_S = 0\ \Omega$, $C_L = 1\text{ nF}$; Test Circuit 7
Off Isolation	-80		dB typ	$R_L = 50\ \Omega$, $C_L = 5\text{ pF}$, $f = 1\text{ MHz}$; Test Circuit 8
Channel-to-Channel Crosstalk	-80		dB typ	$R_L = 50\ \Omega$, $C_L = 5\text{ pF}$, $f = 1\text{ MHz}$; Test Circuit 9
-3 dB Bandwidth	160		MHz typ	$R_L = 50\ \Omega$, $C_L = 5\text{ pF}$, Test Circuit 10
C_S (OFF)	11		pF typ	$f = 1\text{ MHz}$
C_D , C_S (ON)	34		pF typ	$f = 1\text{ MHz}$
POWER REQUIREMENTS				
I_{DD}	0.001		μA typ	$V_{DD} = 3.3\text{ V}$; Digital Inputs = 0 V or 3.3 V
		1.0	μA max	

NOTES¹Temperature ranges are as follows: B Version: -40°C to +85°C.²Guaranteed by design, not subject to production test.

Specifications subject to change without notice.

ADG786/ADG788—SPECIFICATIONS¹

DUAL SUPPLY ($V_{DD} = +2.5\text{ V} \pm 10\%$, $V_{SS} = -2.5\text{ V} \pm 10\%$, $GND = 0\text{ V}$, unless otherwise noted.)

Parameter	B Version		Unit	Test Conditions/Comments
	+25°C	-40°C to +85°C		
ANALOG SWITCH				
Analogue Signal Range		V_{SS} to V_{DD}	V	
On Resistance (R_{ON})	2.5		Ω typ	$V_S = V_{SS}$ to V_{DD} , $I_{DS} = 10\text{ mA}$; Test Circuit 1
	4.5	5.0	Ω max	
On-Resistance Match between Channels (ΔR_{ON})		0.1	Ω typ	$V_S = V_{SS}$ to V_{DD} , $I_{DS} = 10\text{ mA}$
		0.4	Ω max	
On-Resistance Flatness ($R_{FLAT(ON)}$)	0.5		Ω typ	$V_S = V_{SS}$ to V_{DD} , $I_{DS} = 10\text{ mA}$
		1.2	Ω max	
LEAKAGE CURRENTS				
Source OFF Leakage I_S (OFF)	± 0.01		nA typ	$V_{DD} = +2.75\text{ V}$, $V_{SS} = -2.75\text{ V}$ $V_S = +2.25\text{ V}/-1.25\text{ V}$, $V_D = -1.25\text{ V}/+2.25\text{ V}$; Test Circuit 2
	± 0.1	± 0.3	nA max	
Channel ON Leakage I_D , I_S (ON)	± 0.01		nA typ	$V_S = V_D = +2.25\text{ V}/-1.25\text{ V}$, Test Circuit 3
	± 0.1	± 0.5	nA max	
DIGITAL INPUTS				
Input High Voltage, V_{INH}		1.7	V min	
Input Low Voltage, V_{INL}		0.7	V max	
Input Current I_{INL} or I_{INH}	0.005		μA typ	$V_{IN} = V_{INL}$ or V_{INH}
		± 0.1	μA max	
C_{IN} , Digital Input Capacitance	4		pF typ	
DYNAMIC CHARACTERISTICS²				
t_{ON}	21	35	ns typ ns max	$R_L = 300\ \Omega$, $C_L = 35\text{ pF}$; $V_{S1A} = 1.5\text{ V}$, $V_{S1B} = 0\text{ V}$, Test Circuit 4
t_{OFF}	10	16	ns typ ns max	$R_L = 300\ \Omega$, $C_L = 35\text{ pF}$; $V_S = 1.5\text{ V}$, Test Circuit 4
ADG786 $t_{ON}(\overline{EN})$	21	40	ns typ ns max	$R_L = 300\ \Omega$, $C_L = 35\text{ pF}$; $V_S = 1.5\text{ V}$, Test Circuit 5
$t_{OFF}(\overline{EN})$	10	16	ns typ ns max	$R_L = 300\ \Omega$, $C_L = 35\text{ pF}$; $V_S = 1.5\text{ V}$, Test Circuit 5
Break-Before-Make Time Delay, t_D	13	1	ns typ ns min	$R_L = 300\ \Omega$, $C_L = 35\text{ pF}$; $V_S = 1.5\text{ V}$, Test Circuit 6
Charge Injection	± 5		pC typ	$V_S = 0\text{ V}$, $R_S = 0\ \Omega$, $C_L = 1\text{ nF}$; Test Circuit 7
Off Isolation	-80		dB typ	$R_L = 50\ \Omega$, $C_L = 5\text{ pF}$, $f = 1\text{ MHz}$; Test Circuit 8
Channel-to-Channel Crosstalk	-80		dB typ	$R_L = 50\ \Omega$, $C_L = 5\text{ pF}$, $f = 1\text{ MHz}$; Test Circuit 9
-3 dB Bandwidth	160		MHz typ	$R_L = 50\ \Omega$, $C_L = 5\text{ pF}$, Test Circuit 10
C_S (OFF)	11		pF typ	$f = 1\text{ MHz}$
C_D , C_S (ON)	34		pF typ	$f = 1\text{ MHz}$
POWER REQUIREMENTS				
I_{DD}	0.001		μA typ	$V_{DD} = +2.75\text{ V}$ Digital Inputs = 0 V or 2.75 V
		1.0	μA max	
I_{SS}	0.001		μA typ	$V_{SS} = -2.75\text{ V}$ Digital Inputs = 0 V or 2.75 V
		1.0	μA max	

NOTES

¹Temperature range is as follows: B Version: -40°C to +85°C.

²Guaranteed by design, not subject to production test.

Specifications subject to change without notice.

ABSOLUTE MAXIMUM RATINGS¹

(T_A = 25°C unless otherwise noted)

V _{DD} to V _{SS}	7 V
V _{DD} to GND	-0.3 V to +7 V
V _{SS} to GND	+0.3 V to -3.5 V
Analog Inputs ²	V _{SS} - 0.3 V to V _{DD} + 0.3 V or 30 mA, Whichever Occurs First
Digital Inputs ²	-0.3 V to V _{DD} + 0.3 V or 30 mA, Whichever Occurs First
Peak Current, S or D	100 mA (Pulsed at 1 ms, 10% Duty Cycle max)
Continuous Current, S or D	30 mA
Operating Temperature Range	
Industrial (A, B Versions)	-40°C to +85°C

Storage Temperature Range	-65°C to +150°C
Junction Temperature	150°C
20 Lead CSP, θ _{JA} Thermal Impedance	32°C/W
Lead Temperature, Soldering (10 sec)	300°C
IR Reflow, Peak Temperature	220°C

NOTES

¹Stresses above those listed under Absolute Maximum Ratings may cause permanent damage to the device. This is a stress rating only; functional operation of the device at these or any other conditions above those listed in the operational sections of this specification is not implied. Exposure to absolute maximum rating conditions for extended periods may affect device reliability. Only one absolute maximum rating may be applied at any one time.

²Overtoggles at A, EN, IN, S, or D will be clamped by internal diodes. Current should be limited to the maximum ratings given.

CAUTION

ESD (electrostatic discharge) sensitive device. Electrostatic charges as high as 4000 V readily accumulate on the human body and test equipment and can discharge without detection. Although the ADG786/ADG788 features proprietary ESD protection circuitry, permanent damage may occur on devices subjected to high-energy electrostatic discharges. Therefore, proper ESD precautions are recommended to avoid performance degradation or loss of functionality.



PIN CONFIGURATIONS

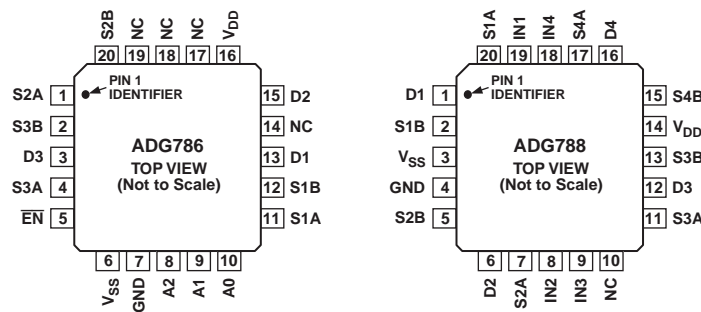

NC = NO CONNECT
EXPOSED PAD TIED TO SUBSTRATE, V_{SS}

ADG786/ADG788

Table I. ADG786 Truth Table

A2	A1	A0	$\overline{\text{EN}}$	ON Switch
X	X	X	1	None
0	0	0	0	D1-S1A, D2-S2A, D3-S3A
0	0	1	0	D1-S1B, D2-S2A, D3-S3A
0	1	0	0	D1-S1A, D2-S2B, D3-S3A
0	1	1	0	D1-S1B, D2-S2B, D3-S3A
1	0	0	0	D1-S1A, D2-S2A, D3-S3B
1	0	1	0	D1-S1B, D2-S2A, D3-S3B
1	1	0	0	D1-S1A, D2-S2B, D3-S3B
1	1	1	0	D1-S1B, D2-S2B, D3-S3B

Table II. ADG788 Truth Table

Logic	Switch A	Switch B
0	OFF	ON
1	ON	OFF

TERMINOLOGY

V_{DD}	Most Positive Power Supply Potential
V_{SS}	Most Negative Power Supply in a Dual Supply Application. In single supply applications, this should be tied to ground close to the device.
I_{DD}	Positive Supply Current
I_{SS}	Negative Supply Current
GND	Ground (0 V) Reference
S	Source Terminal. May be an input or output
D	Drain Terminal. May be an input or output
IN	Logic Control Input
$V_D (V_S)$	Analog Voltage on Terminals D, S
R_{ON}	Ohmic Resistance between D and S
ΔR_{ON}	On Resistance Match between Any Two Channels, i.e., $R_{ONmax} - R_{ONmin}$.
$R_{FLAT(ON)}$	Flatness is defined as the difference between the maximum and minimum value of on-resistance as measured over the specified analog signal range.
I_S (OFF)	Source Leakage Current with the Switch "OFF"
I_D, I_S (ON)	Channel Leakage Current with the Switch "ON"
V_{INL}	Maximum Input Voltage for Logic "0"
V_{INH}	Minimum Input Voltage for Logic "1"
$I_{INL} (I_{INH})$	Input Current of the Digital Input
C_S (OFF)	"OFF" Switch Source Capacitance. Measured with reference to ground.
$C_D, C_S(ON)$	"ON" Switch Capacitance. Measured with reference to ground.
C_{IN}	Digital Input Capacitance
t_{ON}	Delay time measured between the 50% and 90% points of the digital inputs and the switch "ON" condition.
t_{OFF}	Delay time measured between the 50% and 90% points of the digital input and the switch "OFF" condition.
$t_{ON}(\overline{\text{EN}})$	Delay time between the 50% and 90% points of the $\overline{\text{EN}}$ digital input and the switch "ON" condition.
$t_{OFF}(\overline{\text{EN}})$	Delay time between the 50% and 90% points of the $\overline{\text{EN}}$ digital input and the switch "OFF" condition.
t_{OPEN}	"OFF" time measured between the 80% points of both switches when switching from one address state to another.
Charge	A measure of the glitch impulse transferred Injection from the digital input to the analog output during switching.
Off Isolation	A measure of unwanted signal coupling through an "OFF" switch.
Crosstalk	A measure of unwanted signal that is coupled through from one channel to another as a result of parasitic capacitance.
On Response	The Frequency Response of the "ON" Switch
Insertion Loss	The Loss Due to the ON Resistance of the Switch.

Typical Performance Characteristics- ADG786/ADG788

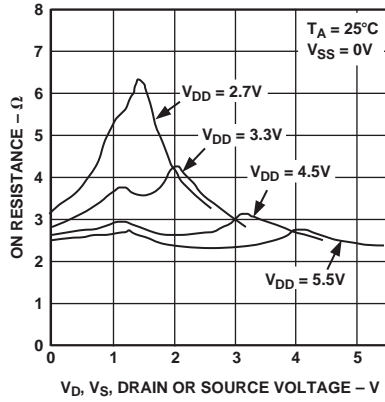

TPC 1. On Resistance as a Function of $V_D(V_S)$ for Single Supply

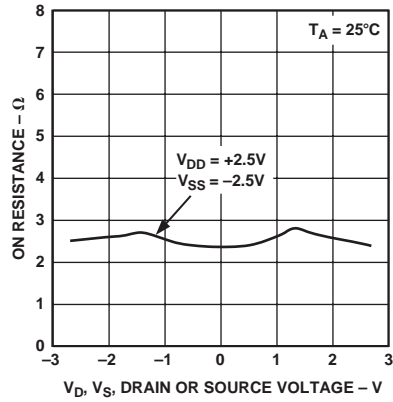

TPC 2. On Resistance as a Function of $V_D(V_S)$ for Dual Supply

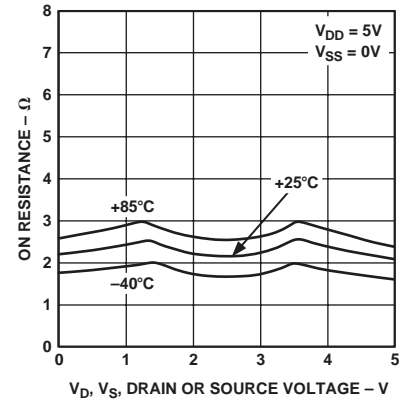

TPC 3. On Resistance as a Function of $V_D(V_S)$ for Different Temperatures, Single Supply

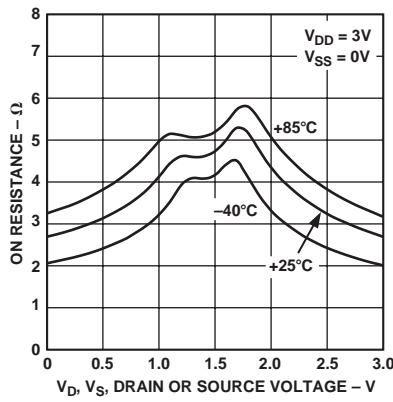

TPC 4. On Resistance as a Function of $V_D(V_S)$ for Different Temperatures, Single Supply

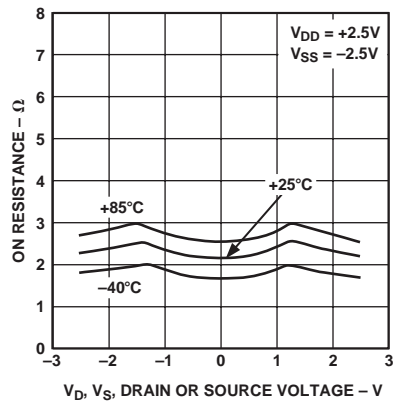

TPC 5. On Resistance as a Function of $V_D(V_S)$ for Different Temperatures, Dual Supply

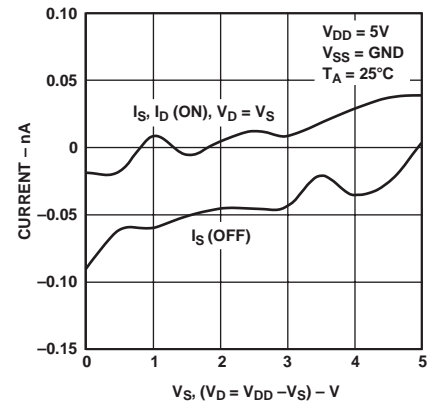

TPC 6. Leakage Currents as a Function of $V_D(V_S)$

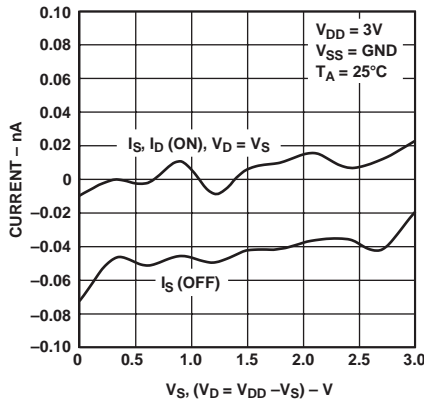

TPC 7. Leakage Currents as a Function of $V_D(V_S)$

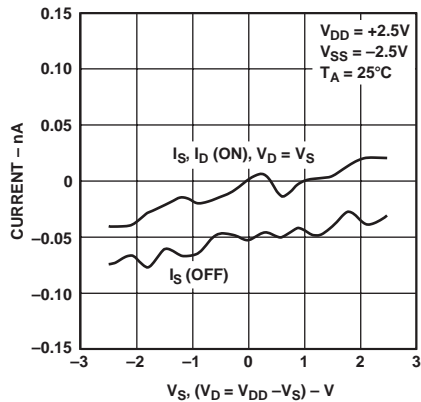

TPC 8. Leakage Currents as a Function of $V_D(V_S)$

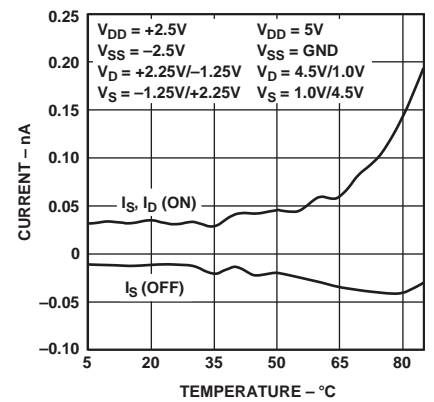

TPC 9. Leakage Currents as a Function of Temperature

ADG786/ADG788

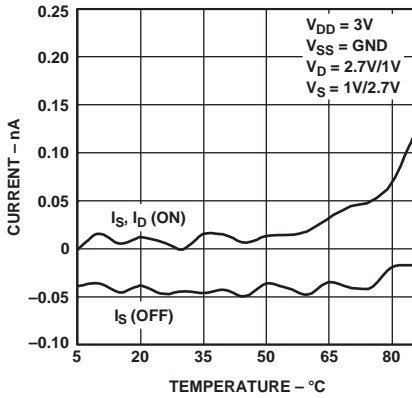

TPC 10. Leakage Currents as a Function of Temperature

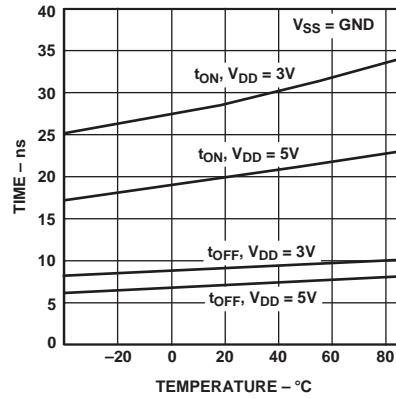

TPC 11. t_{ON}/t_{OFF} Times vs. Temperature

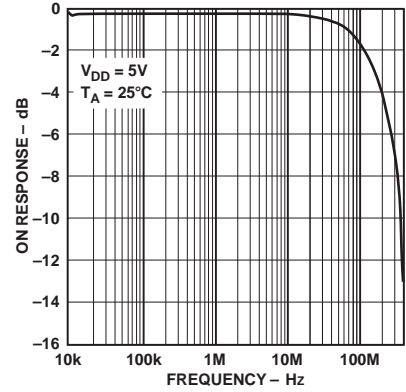

TPC 12. On Response vs. Frequency

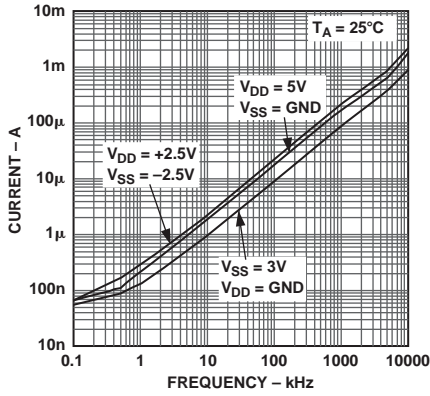

TPC 13. Input Current, I_{DD} vs. Switching Frequency

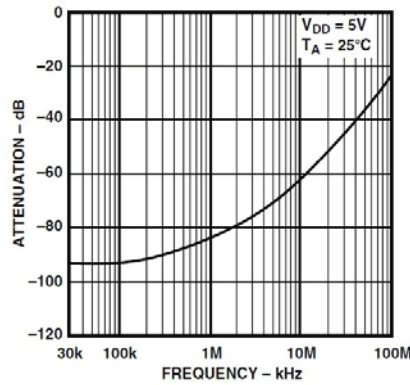

TPC 14. Off Isolation vs. Frequency

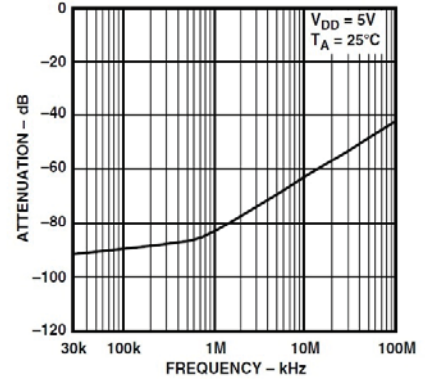

TPC 15. Crosstalk vs. Frequency

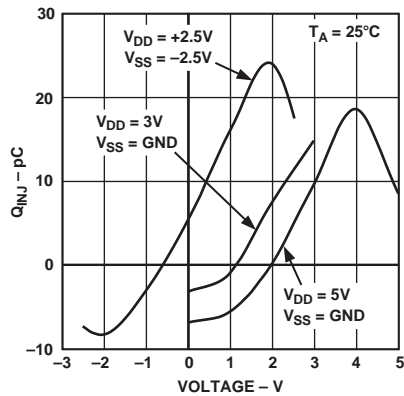

TPC 16. Charge Injection vs. Source Voltage

Test Circuits

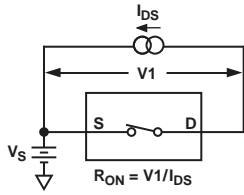

Test Circuit 1. On Resistance

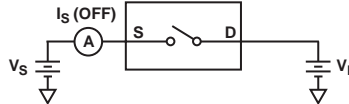

Test Circuit 2. I_S (OFF)

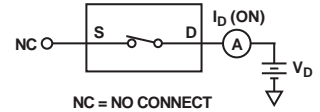

Test Circuit 3. I_D (ON)

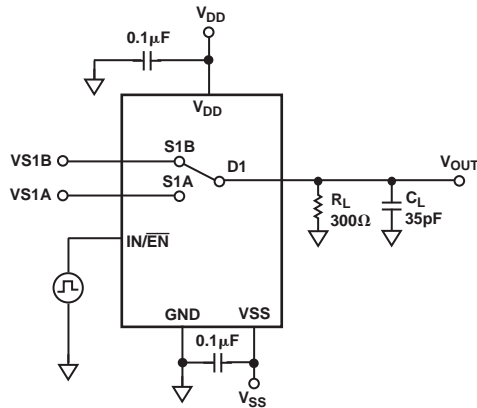

Test Circuit 4. Switching Times, t_{ON} , t_{OFF}

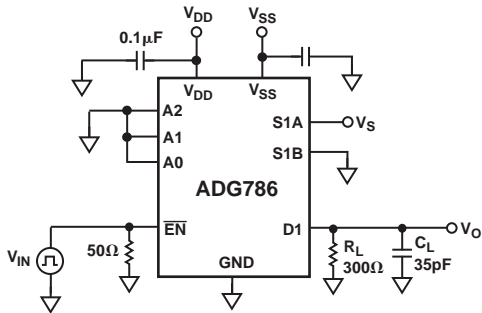

Test Circuit 5. Enable Delay, $t_{ON}(\overline{EN})$, $t_{OFF}(\overline{EN})$

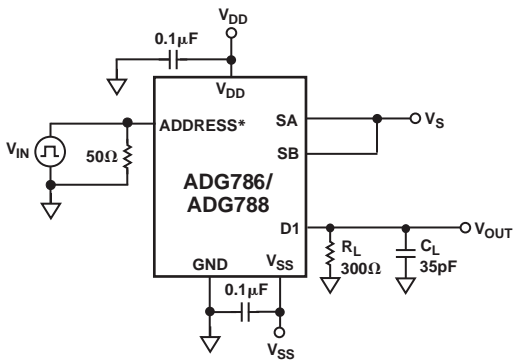

*A0, A1, A2 for ADG786, IN1-4 for ADG788

Test Circuit 6. Break-Before-Make Delay, t_{OPEN}

ADG786/ADG788

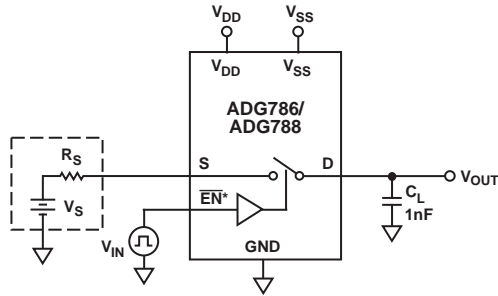

* IN1-4 for ADG734

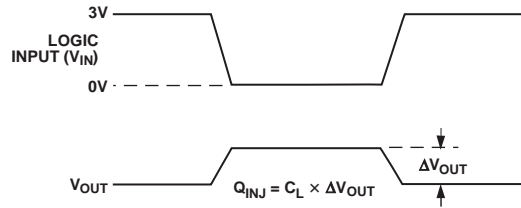

Test Circuit 7. Charge Injection

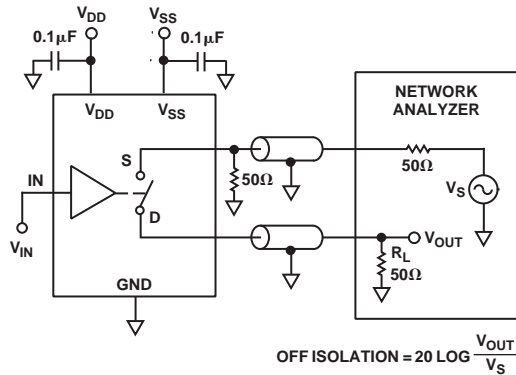

$$\text{OFF ISOLATION} = 20 \text{ LOG } \frac{V_{\text{OUT}}}{V_S}$$

Test Circuit 8. OFF Isolation

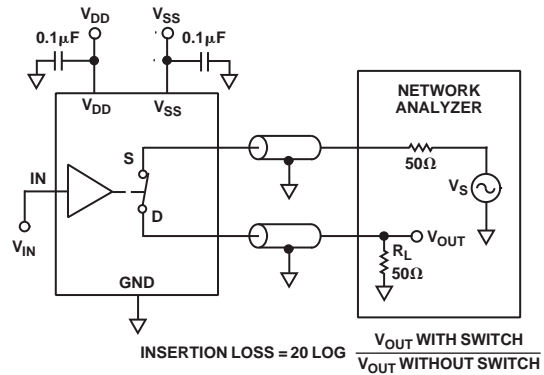

$$\text{INSERTION LOSS} = 20 \text{ LOG } \frac{V_{\text{OUT WITH SWITCH}}}{V_{\text{OUT WITHOUT SWITCH}}}$$

Test Circuit 10. Bandwidth

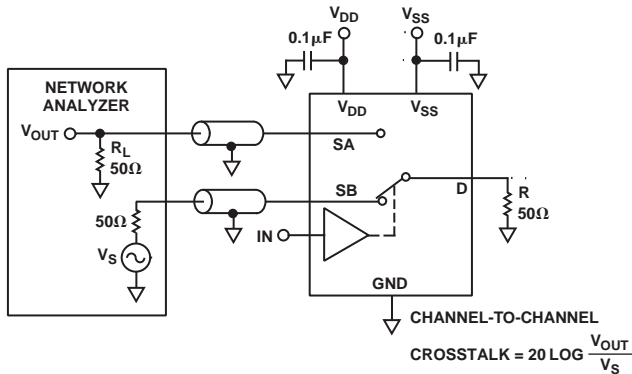

$$\text{CHANNEL-TO-CHANNEL CROSSTALK} = 20 \text{ LOG } \frac{V_{\text{OUT}}}{V_S}$$

Test Circuit 9. Channel-to-Channel Crosstalk

Power Supply Sequencing

When using CMOS devices, care must be taken to ensure correct power supply sequencing. Incorrect sequencing can result in the device being subjected to stresses beyond those maximum ratings listed in the data sheet. Digital and analog inputs should be applied to the device after supplies and ground. In dual supply applications, if digital and analog inputs may be applied prior to V_{DD} and V_{SS} supplies, the addition of a Schottky diode connected between V_{SS} and GND will ensure that the device powers on correctly. For single supply applications, V_{SS} should be tied to GND as close to the device as possible.

OUTLINE DIMENSIONS

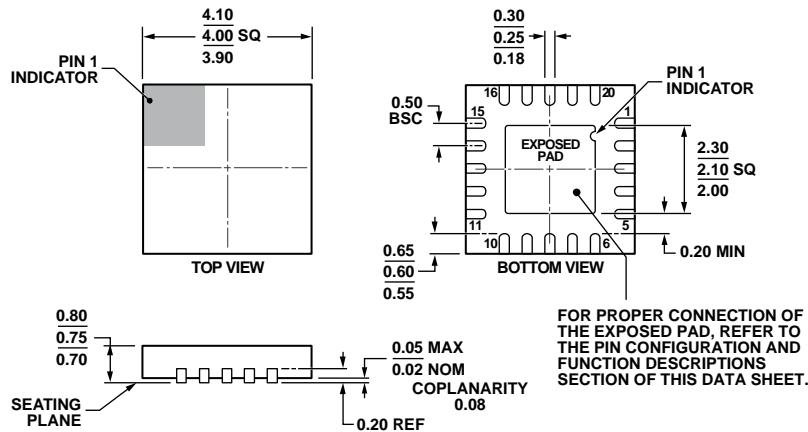

COMPLIANT TO JEDEC STANDARDS MO-220-WGGD-1.

Figure 1. 20-Lead Lead Frame Chip Scale Package [LFCSP]
4 mm x 4 mm Body and 0.75 mm Package Height
(CP-20-6)

Dimensions shown in millimeters

08-16-2010-B

ORDERING GUIDE

Model ^{1,2}	Temperature Range	Package Description	Package Option
ADG786BCPZ	-40°C to +85°C	20-Lead Lead Frame Chip Scale Package [LFCSP]	CP-20-6
ADG786BCPZ-REEL7	-40°C to +85°C	20-Lead Lead Frame Chip Scale Package [LFCSP]	CP-20-6
ADG786WBCPZ-REEL7	-40°C to +85°C	20-Lead Lead Frame Chip Scale Package [LFCSP]	CP-20-6
ADG788BCPZ	-40°C to +85°C	20-Lead Lead Frame Chip Scale Package [LFCSP]	CP-20-6
ADG788BCPZ-REEL	-40°C to +85°C	20-Lead Lead Frame Chip Scale Package [LFCSP]	CP-20-6
ADG788BCPZ-REEL7	-40°C to +85°C	20-Lead Lead Frame Chip Scale Package [LFCSP]	CP-20-6
EVAL-ADG788EBZ		Evaluation Board	

¹ Z = RoHS Compliant Part.

² W = Qualified for Automotive Applications.

AUTOMOTIVE PRODUCTS

The **ADG786W** models are available with controlled manufacturing to support the quality and reliability requirements of automotive applications. Note that these automotive models may have specifications that differ from the commercial models; therefore, designers should review the Specifications section of this data sheet carefully. Only the automotive grade products shown are available for use in automotive applications. Contact your local Analog Devices account representative for specific product ordering information and to obtain the specific Automotive Reliability reports for these models.

REVISION HISTORY

9/15—Rev. B to Rev. C

Change to Functional Block Diagrams	1
Updated Outline Dimensions.....	11
Changes to Ordering Guide.....	11

8/12—Rev. 0 to Rev. A

Updated Outline Dimensions.....	11
Changes to Ordering Guide.....	11
Added Automotive Products Section.....	11

10/13—Rev. A to Rev. B

Changed Off Isolation from -72 dB to -80 dB and Channel-to-Channel Crosstalk from -67 dB to -80 dB (Throughout)	2
Changes to TPC 14 and TPC 15.....	8

7/01—Revision 0: Initial Version

Looking for pricing, stock, or lifecycle information?

Click below to explore more details on WIN SOURCE:

 [View ADG786BCPZ on WIN SOURCE](#)

 [Analog Devices Inc. Information](#)

Optimize Your Supply Chain with WIN SOURCE Solutions

-  Global Sourcing Solution
-  Obsolete Management
-  Cost Control Management
-  Shortage Management
-  Alternative Solution
-  Excess Inventory Management