



**THE DATASHEET OF  
AH372-W-7**



## Description

AH372 is a single-digital-output Hall-Effect latch sensor with internal pull-up resistor for high temperature operation. The device includes an on-chip Hall voltage generator for magnetic sensing, an amplifier to amplify Hall voltage, and a comparator to provide switching hysteresis for noise rejection, and an output driver with a pull-up resistor. An internal band-gap regulator provides a temperature compensated supply voltage for internal circuits and allows a wide operating supply range.

When the magnetic flux density (B) perpendicular to the package is larger than operation point ( $B_{OP}$ ), output is switched on (OUT pin is pulled low). The output state is held on until a magnetic flux density reversal falls below  $B_{RP}$ . When B is less than  $B_{RP}$ , the output is switched off.

The AH372 is available in SIP-3 (Ammo Pack), SIP-3 (Bulk Pack), SC59 and SOT23 packages.

## Features

- Bipolar Hall Effect Latch Operation
- 2.2V to 20V Operating Range
- Single Output with Built-in Pull-up Resistor
- 25mA output Sink Capability
- -40°C to +125°C Operating Temperature
- Industry Standard SIP-3 (Ammo Pack), SIP-3 (Bulk Pack), SC59 and SOT23 Packages
- **Totally Lead-Free & Fully RoHS Compliant (Notes 1 & 2)**
- **Halogen and Antimony Free. "Green" Device (Note 3)**
- **For automotive applications requiring specific change control (i.e. parts qualified to AEC-Q100/101/200, PPAP capable, and manufactured in IATF 16949 certified facilities), please [contact us](#) or your local Diodes representative. <https://www.diodes.com/quality/product-definitions/>**

- Notes:
1. No purposely added lead. Fully EU Directive 2002/95/EC (RoHS), 2011/65/EU (RoHS 2) & 2015/863/EU (RoHS 3) compliant.
  2. See <https://www.diodes.com/quality/lead-free/> for more information about Diodes Incorporated's definitions of Halogen- and Antimony-free, "Green" and Lead-free.
  3. Halogen- and Antimony-free "Green" products are defined as those which contain <900ppm bromine, <900ppm chlorine (<1500ppm total Br + Cl) and <1000ppm antimony compounds.

## Pin Assignments

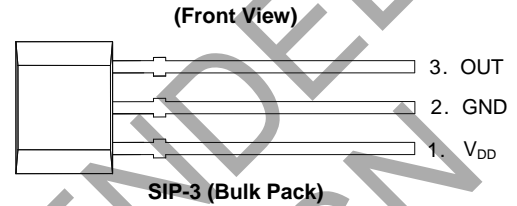
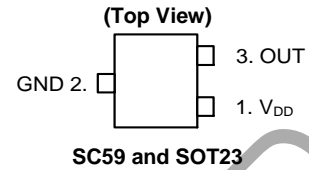

## Applications

- Rotor Position Sensing for Motor Commutation
- Encoder
- Speed Measurement – RPM Monitor
- Contact-Less Current Switch

## Typical Application Circuits

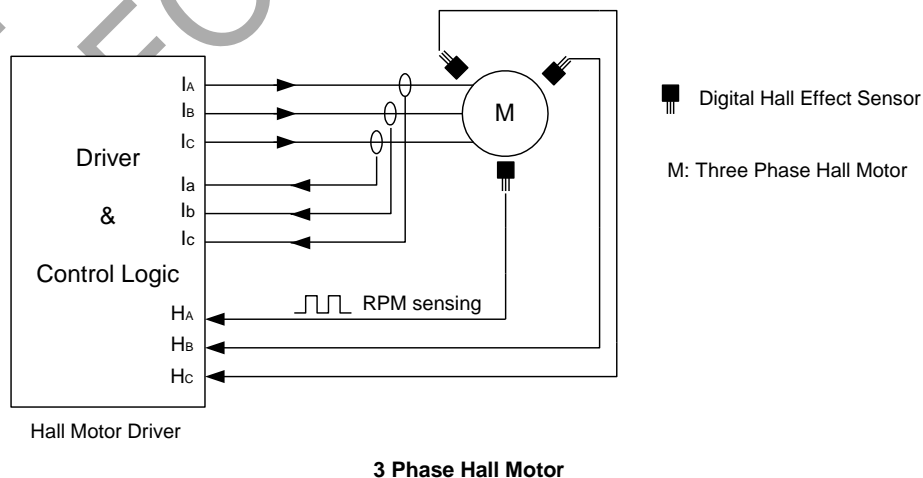

**Typical Application Circuits** (cont.)

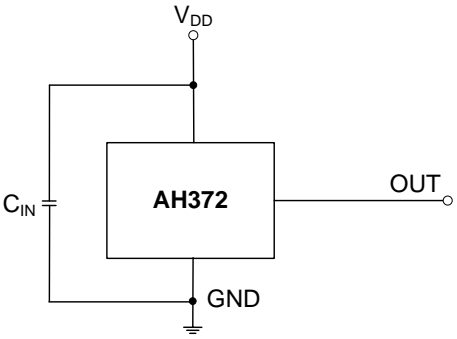

**Typical AH372 Circuit**

Note: 4. C<sub>IN</sub> is for power stabilization and to strengthen the noise immunity, the recommended capacitance is 100nF typical.

**Pin Descriptions**

Packages: SC59, SOT23, SIP-3 (Ammo Pack) and SIP-3 (Bulk Pack)

Pin Number	Pin Name	Function
1	V <sub>DD</sub>	Power Supply Input
2	GND	Ground
3	OUT	Output

**Functional Block Diagram**

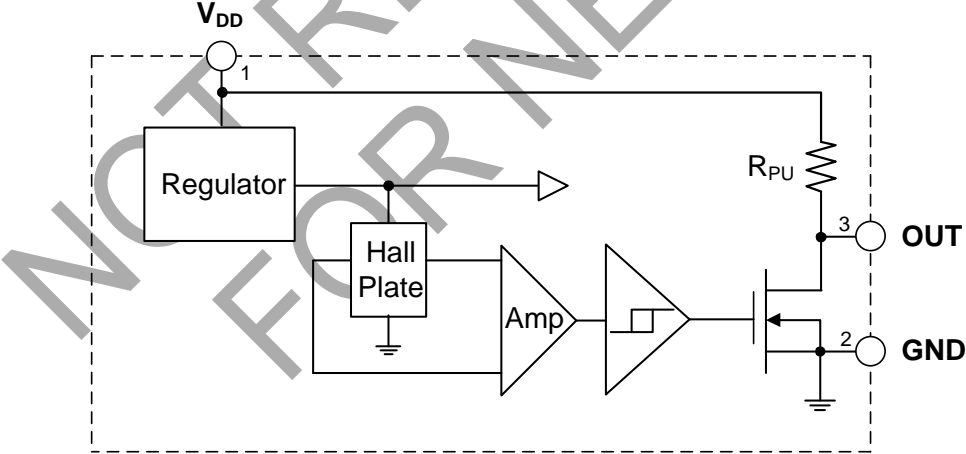

### Absolute Maximum Ratings (Note 5) @ $T_A = +25^\circ\text{C}$ , unless otherwise specified.)

Symbol	Characteristics	Values	Unit	
$V_{DD}$	Supply Voltage (Note 6)	28	V	
$V_{OUT(OFF)}$	Output "Off" Voltage	28	V	
$I_{O(SINK)}$	Output "On" Current (Sink)	25	mA	
B	Magnetic Flux Density	Unlimited		
$P_D$	Package Power Dissipation	SIP-3 (Ammo Pack) and SIP-3 (Bulk Pack)	550	mW
		SC59 and SOT23	230	mW
$T_{STG}$	Storage Temperature Range	-65 to +150	$^\circ\text{C}$	
$T_J$	Maximum Junction Temperature	+150	$^\circ\text{C}$	

- Notes:
- Stresses greater than the 'Absolute Maximum Ratings' specified above can cause permanent damage to the device. These are stress ratings only; functional operation of the device at these or any other conditions exceeding those indicated in this specification is not implied. Device reliability can be affected by exposure to absolute maximum rating conditions for extended periods of time.
  - The absolute maximum  $V_{DD}$  of 28V is a transient stress rating and is not meant as a functional operating condition. It is not recommended to operate the device at the absolute maximum rated conditions for any period of time.

### Recommended Operating Conditions (@ $T_A = +25^\circ\text{C}$ , unless otherwise specified.)

Symbol	Characteristic	Conditions	Rating	Unit
$V_{DD}$	Supply Voltage (Note 7)	Operating	2.2 to 20	V
$T_A$	Operating Temperature Range	Operating	-40 to +125	$^\circ\text{C}$

- Note: 7. The output of IC will be switched after the supply voltage is over 2.2V, but the magnetic characteristics will not be normal until the supply is over 2.5V.

### Electrical Characteristics (@ $T_A = +25^\circ\text{C}$ , $V_{DD} = 12\text{V}$ , unless otherwise specified.)

Symbol	Characteristic	Conditions	Min	Typ	Max	Unit
$V_{OUT}$	Output On Voltage	$I_{OUT} = 20\text{mA}$	—	300	400	mV
$I_{DD}$	Supply Current	$B < B_{RP}$	—	2	4	mA
$I_{OFF}$	Output Leakage Current	Output off	—	< 0.1	10	$\mu\text{A}$
$R_{PU}$	Internal Pull-up Resistor	—	7	10	13	$\text{k}\Omega$

**Magnetic Characteristics** (Note 8) (@T<sub>A</sub> = +25°C, V<sub>DD</sub> = 2.5V to 20V, unless otherwise specified.)

(1mT=10 Gauss)

Symbol	Characteristic	Min	Typ	Max	Unit
B <sub>OP</sub> (South Pole to Part Marking Side for SIP-3 (Ammo Pack), SIP-3 (Bulk Pack) and SOT23; North Pole to Part Marking Side for SC59 )	Operation Point	5	30	60	Gauss
B <sub>RP</sub> (South Pole to Part Marking Side for SIP-3 (Ammo Pack), SIP-3 (Bulk Pack) and SOT23; North Pole to Part Marking Side for SC59 )	Release Point	-60	-30	-5	
B <sub>HY</sub> ( B <sub>OPX</sub>  - B <sub>RPX</sub>  )	Hysteresis	—	60	—	

Note: 8. The magnetic characteristics may vary with supply voltage, operating temperature and after soldering.

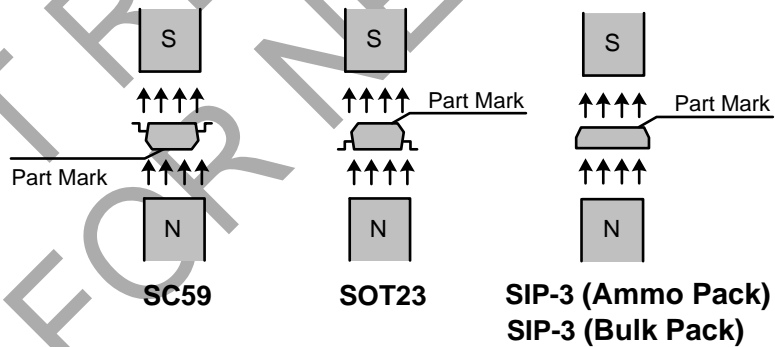
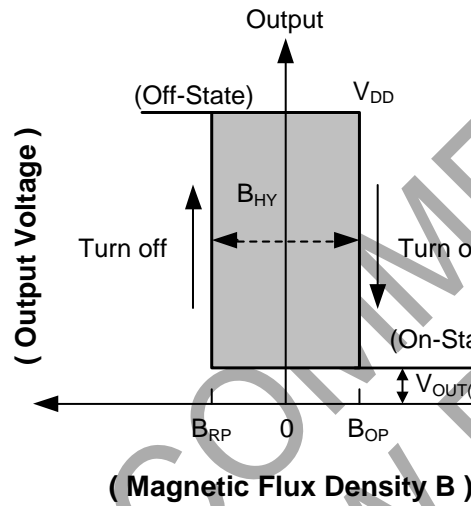

**Thermal Performance Characteristics**

**(1) Package Types: SIP-3 (Ammo Pack) and SIP-3 (Bulk Pack)**

T <sub>A</sub> (°C)	25	50	60	70	80	85	90	95	100	105	110	115	120	125	130	135	140	150
P <sub>D</sub> (mW)	550	440	396	352	308	286	264	242	220	198	176	154	132	110	88	66	44	0

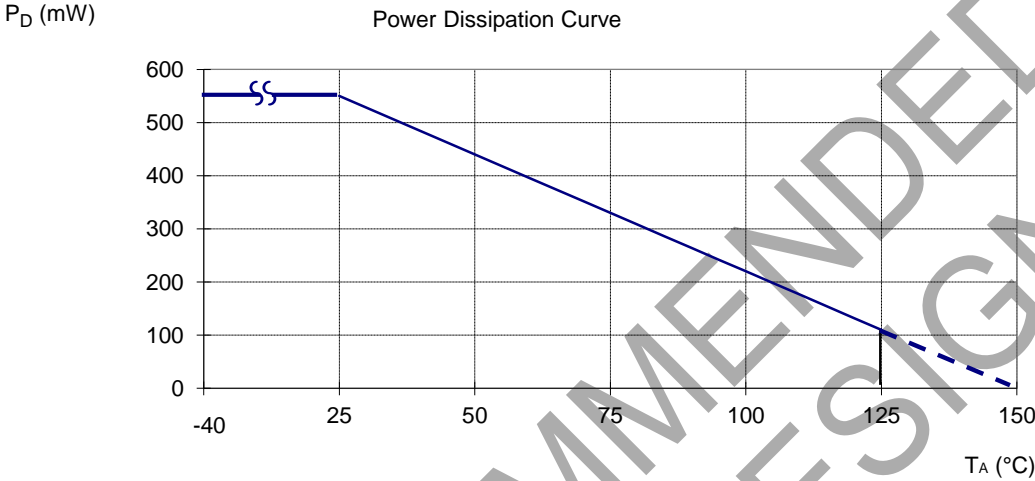

**(2) Package Types: SC59 and SOT23**

T <sub>A</sub> (°C)	25	50	60	70	80	85	90	100	110	120	130	140	150
P <sub>D</sub> (mW)	230	184	166	147	129	120	110	92	74	55	37	18	0

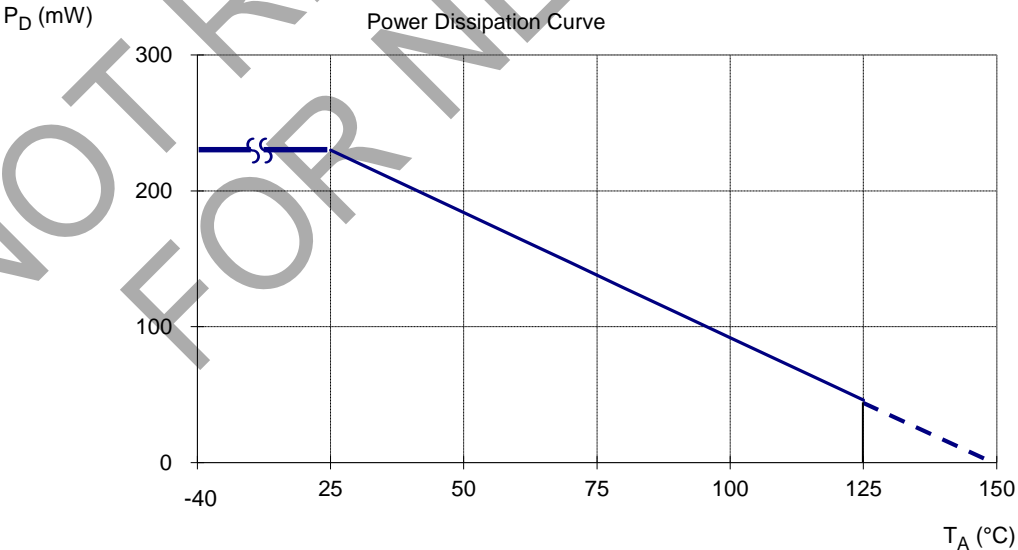

## Ordering Information

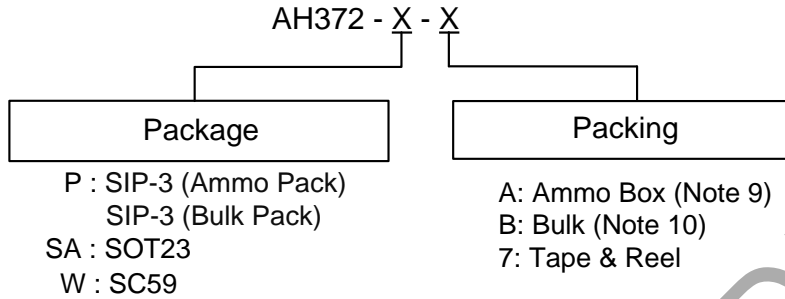

Part Number	Package Code	Packaging (Note 11)	Bulk		7" Tape and Reel		Ammo Box	
			Quantity	Part Number Suffix	Quantity	Part Number Suffix	Quantity	Part Number Suffix
AH372-P-A	P	SIP-3 (Ammo Pack)	NA	NA	NA	NA	4000/Box	-A
AH372-P-B	P	SIP-3 (Bulk Pack)	1000	-B	NA	NA	NA	NA
AH372-SA-7	SA	SOT23	NA	NA	3000/Tape & Reel	-7	NA	NA
AH372-W-7	W	SC59	NA	NA	3000/Tape & Reel	-7	NA	NA

Notes: 9. Ammo Box is for SIP-3 (Ammo Pack) Spread Lead.  
 10. Bulk is for SIP-3 (Bulk Pack) Straight Lead.  
 11. Reverse taping as shown on Diodes Incorporated's Surface Mount (SMD) Packaging document AP02007, which can be found on our website <https://www.diodes.com/assets/Packaging-Support-Docs/ap02007.pdf>.

## Marking Information

(1) Package Types: SC59 and SOT23

( Top View )

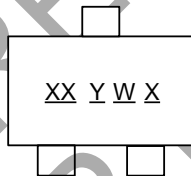

XX : Identification Code  
 Y : Year 0 to 9  
 W : Week : A to Z : 1 to 26 Week;  
 a to z : 27 to 52 Week; z Represents  
 52 and 53 Week  
 X : Internal Code

Part Number	Package	Identification Code
AH372	SC59	XH
AH372	SOT23	YH

(2) Package Types: SIP-3 (Ammo Pack) and SIP-3 (Bulk Pack)

( Front View )

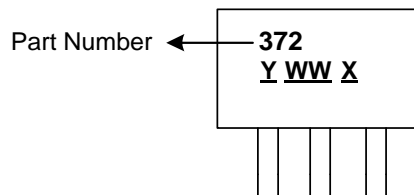

Y : Year : 0~9  
 WW : Week : 01~52, "52" Represents  
 52 and 53 Week  
 X : Internal Code

**Package Outline Dimensions**

Please see <http://www.diodes.com/package-outlines.html> for the latest version.

(1) Package Type: SC59

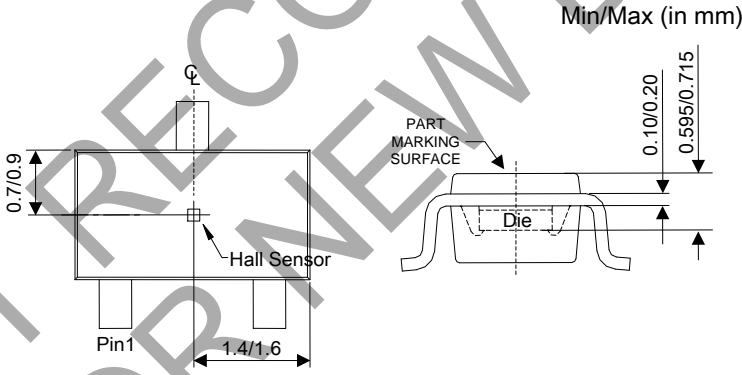
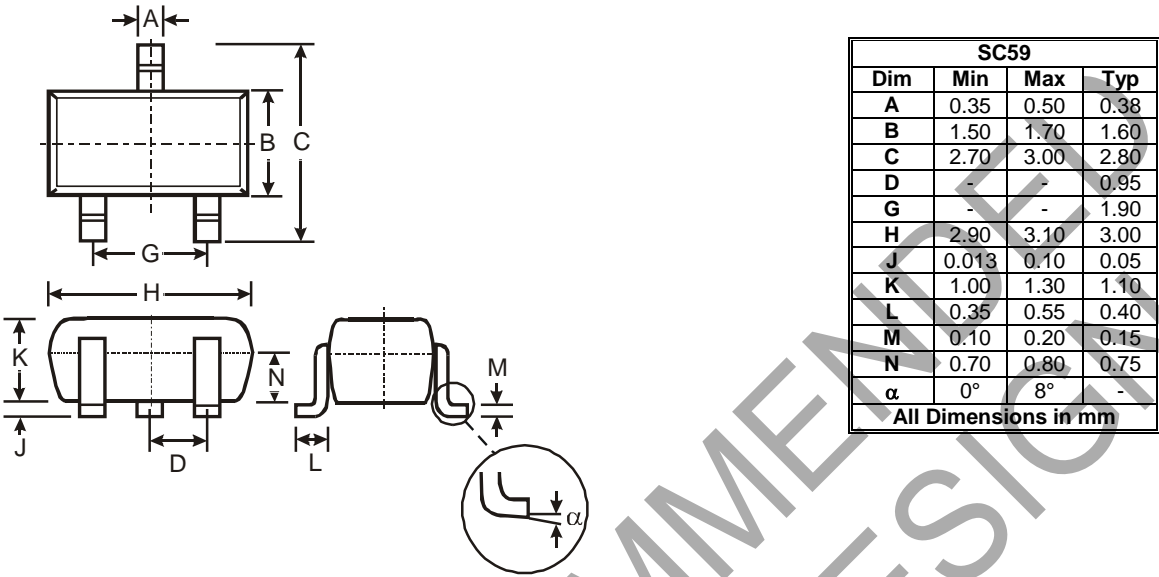

**Sensor Location**

**Package Outline Dimensions (cont.)**

Please see <http://www.diodes.com/package-outlines.html> for the latest version.

**(2) Package Type: SOT23**

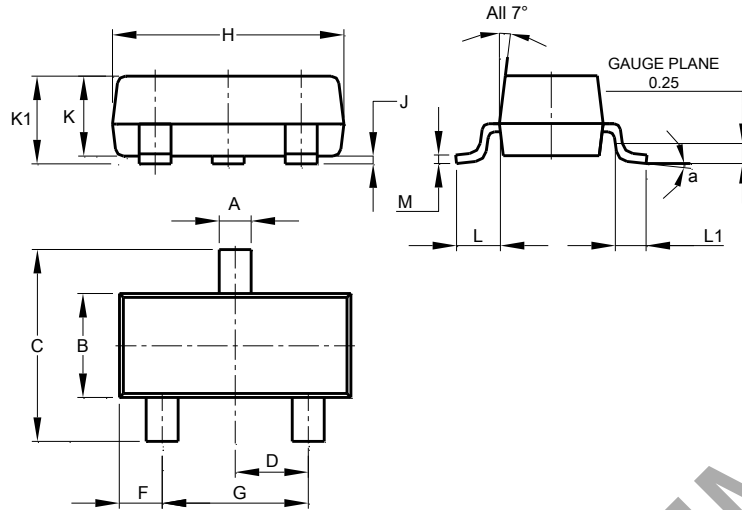

SOT23			
Dim	Min	Max	Typ
A	0.37	0.51	0.40
B	1.20	1.40	1.30
C	2.30	2.50	2.40
D	0.89	1.03	0.915
F	0.45	0.60	0.535
G	1.78	2.05	1.83
H	2.80	3.00	2.90
J	0.013	0.10	0.05
K	0.890	1.00	0.975
K1	0.903	1.10	1.025
L	0.45	0.61	0.55
L1	0.25	0.55	0.40
M	0.085	0.150	0.110
a	0°	8°	--
All Dimensions in mm			

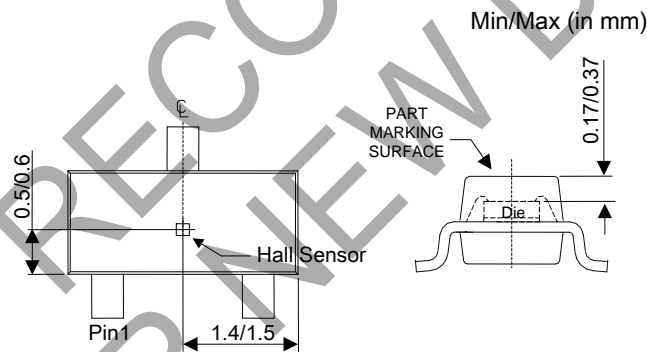

**Sensor Location**

NOT RECOMMENDED FOR DESIGN

**Package Outline Dimensions (cont.)**

Please see <http://www.diodes.com/package-outlines.html> for the latest version.

**(3) Package Type: SIP-3 (Bulk Pack)**

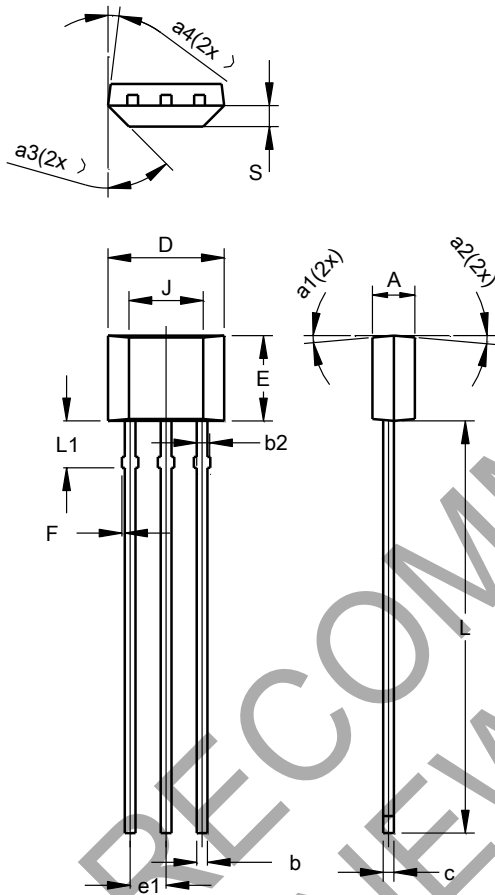

SIP-3 (Bulk Pack)			
Dim	Min	Max	Typ
A	1.40	1.60	1.50
b	0.33	0.43	0.38
b2	0.40	0.508	0.46
c	0.35	0.41	0.38
D	3.90	4.30	4.10
E	2.80	3.20	3.00
e1	1.24	1.30	1.27
F	0.00	0.20	--
J	2.62 REF		
L	14.00	15.00	14.50
L1	1.55	1.75	1.65
S	0.63	0.84	0.74
a1	--	--	5°
a2	--	--	5°
a3	--	--	45°
a4	--	--	3°
All Dimensions in mm			

Note: 12. SIP-3 (Bulk Pack) - Thickness J includes Burrs

NOT RECOMMENDED FOR NEW DESIGN

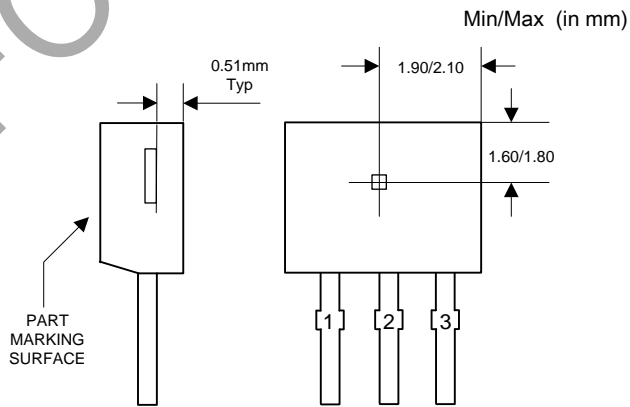

**Sensor Location**

**Package Outline Dimensions (cont.)**

Please see <http://www.diodes.com/package-outlines.html> for the latest version.

**(4) Package Type: SIP-3 (Ammo Pack)**

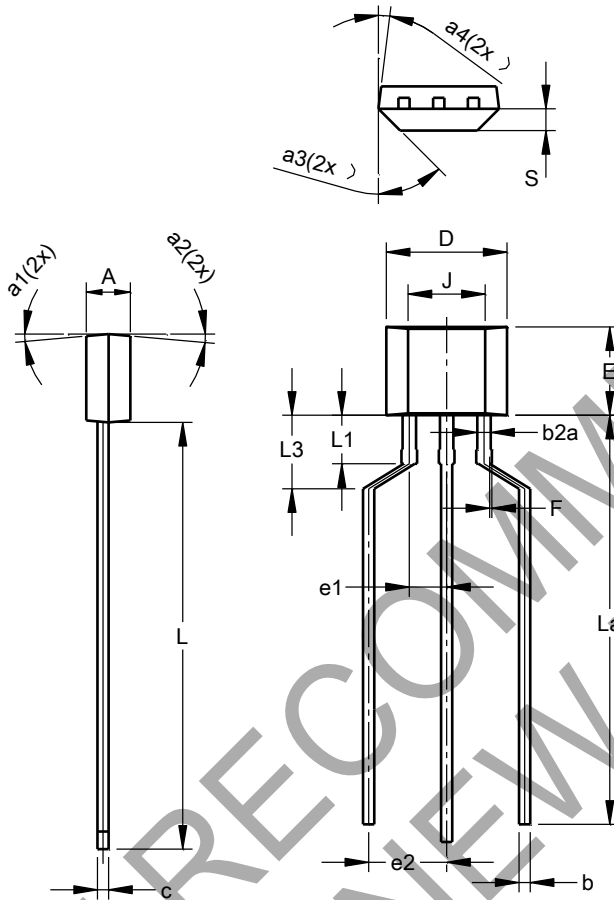

SIP-3 (Ammo Pack)			
Dim	Min	Max	Typ
A	1.40	1.60	1.50
b	0.33	0.43	0.38
b2a	0.40	0.52	0.46
c	0.35	0.41	0.38
D	3.90	4.30	4.10
E	2.80	3.20	3.00
e1	1.24	1.30	1.27
e2	2.40	2.90	2.65
F	0.00	0.20	--
J	2.62 REF		
L	14.00	15.00	14.50
La	12.90	14.90	13.90
L1	1.55	1.75	1.65
L3	2.00	3.00	2.50
S	0.63	0.84	0.74
a1	--	--	5°
a2	--	--	5°
a3	--	--	45°
a4	--	--	3°
All Dimensions in mm			

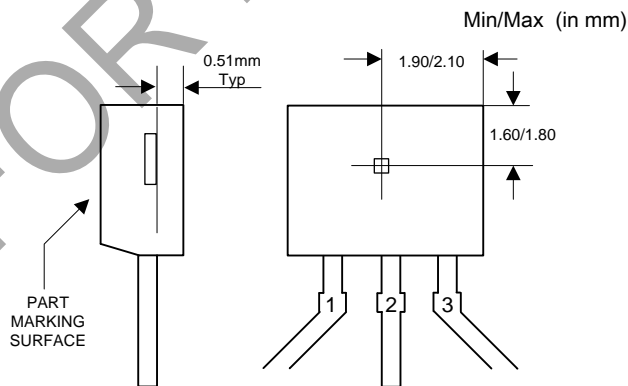

**Suggested Pad Layout**

Please see <http://www.diodes.com/package-outlines.html> for the latest version.

(1) Package Type: SC59

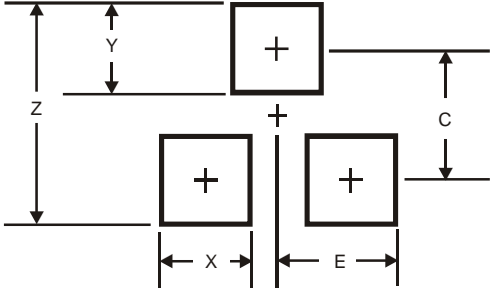

Dimensions	Value (in mm)
Z	3.4
X	0.8
Y	1.0
C	2.4
E	1.35

(2) Package Type: SOT23

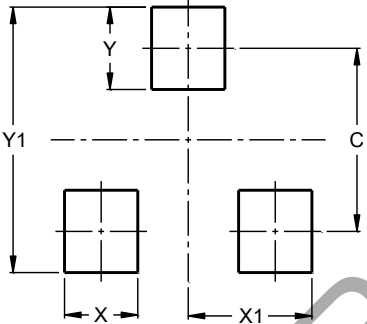

Dimensions	Value (in mm)
C	2.0
X	0.8
X1	1.35
Y	0.9
Y1	2.9

NOT RECOMMENDED FOR NEW DESIGN

**IMPORTANT NOTICE**



1. DIODES INCORPORATED AND ITS SUBSIDIARIES (“DIODES”) MAKE NO WARRANTY OF ANY KIND, EXPRESS OR IMPLIED, WITH REGARDS TO ANY INFORMATION CONTAINED IN THIS DOCUMENT, INCLUDING, BUT NOT LIMITED TO, THE IMPLIED WARRANTIES OF MERCHANTABILITY, FITNESS FOR A PARTICULAR PURPOSE OR NON-INFRINGEMENT OF THIRD PARTY INTELLECTUAL PROPERTY RIGHTS (AND THEIR EQUIVALENTS UNDER THE LAWS OF ANY JURISDICTION).
2. The Information contained herein is for informational purpose only and is provided only to illustrate the operation of Diodes products described herein and application examples. Diodes does not assume any liability arising out of the application or use of this document or any product described herein. This document is intended for skilled and technically trained engineering customers and users who design with Diodes products. Diodes products may be used to facilitate safety-related applications; however, in all instances customers and users are responsible for (a) selecting the appropriate Diodes products for their applications, (b) evaluating the suitability of the Diodes products for their intended applications, (c) ensuring their applications, which incorporate Diodes products, comply the applicable legal and regulatory requirements as well as safety and functional-safety related standards, and (d) ensuring they design with appropriate safeguards (including testing, validation, quality control techniques, redundancy, malfunction prevention, and appropriate treatment for aging degradation) to minimize the risks associated with their applications.
3. Diodes assumes no liability for any application-related information, support, assistance or feedback that may be provided by Diodes from time to time. Any customer or user of this document or products described herein will assume all risks and liabilities associated with such use, and will hold Diodes and all companies whose products are represented herein or on Diodes’ websites, harmless against all damages and liabilities.
4. Products described herein may be covered by one or more United States, international or foreign patents and pending patent applications. Product names and markings noted herein may also be covered by one or more United States, international or foreign trademarks and trademark applications. Diodes does not convey any license under any of its intellectual property rights or the rights of any third parties (including third parties whose products and services may be described in this document or on Diodes’ website) under this document.
5. Diodes products are provided subject to Diodes’ Standard Terms and Conditions of Sale (<https://www.diodes.com/about/company/terms-and-conditions/terms-and-conditions-of-sales/>) or other applicable terms. This document does not alter or expand the applicable warranties provided by Diodes. Diodes does not warrant or accept any liability whatsoever in respect of any products purchased through unauthorized sales channel.
6. Diodes products and technology may not be used for or incorporated into any products or systems whose manufacture, use or sale is prohibited under any applicable laws and regulations. Should customers or users use Diodes products in contravention of any applicable laws or regulations, or for any unintended or unauthorized application, customers and users will (a) be solely responsible for any damages, losses or penalties arising in connection therewith or as a result thereof, and (b) indemnify and hold Diodes and its representatives and agents harmless against any and all claims, damages, expenses, and attorney fees arising out of, directly or indirectly, any claim relating to any noncompliance with the applicable laws and regulations, as well as any unintended or unauthorized application.
7. While efforts have been made to ensure the information contained in this document is accurate, complete and current, it may contain technical inaccuracies, omissions and typographical errors. Diodes does not warrant that information contained in this document is error-free and Diodes is under no obligation to update or otherwise correct this information. Notwithstanding the foregoing, Diodes reserves the right to make modifications, enhancements, improvements, corrections or other changes without further notice to this document and any product described herein. This document is written in English but may be translated into multiple languages for reference. Only the English version of this document is the final and determinative format released by Diodes.
8. Any unauthorized copying, modification, distribution, transmission, display or other use of this document (or any portion hereof) is prohibited. Diodes assumes no responsibility for any losses incurred by the customers or users or any third parties arising from any such unauthorized use.

Copyright © 2020 Diodes Incorporated

[www.diodes.com](http://www.diodes.com)

## Looking for pricing, stock, or lifecycle information?

Click below to explore more details on WIN SOURCE:

-  [View AH372-W-7 on WIN SOURCE](#)
-  [Diodes Incorporated Information](#)

## Optimize Your Supply Chain with WIN SOURCE Solutions

-  Global Sourcing Solution
-  Obsolete Management
-  Cost Control Management
-  Shortage Management
-  Alternative Solution
-  Excess Inventory Management