



THE DATASHEET OF AP1016AEN





AP1016AEN

9.0V Dual H-Bridge Motor Driver IC

1. General Description

The AP1016 includes 2 channel H-bridge drivers in one package. It also includes Under Voltage Detection and Thermal Shut Down circuits. It is suitable for driving stepper motor and voice coil motors.

2. Features

- 2 channel H-bridge drivers in one package
- Power Supply Voltage Range
 - Control (VC) 2.7V ~ 5.5V
 - Motor (VM) 2.0V ~ 9.0V
- Output Current 0.7A(DC)
- H-Bridge ON Resistance : RDSON (TOP+BOT)=0.54Ω @25°C or 0.72Ω @85°C
- PWM Pulse Input max 200kHz
- Built in Flow-through Current Protection Circuit
- Built in Charge Pump Circuit
- Built in UVLO & TSD Circuits
- Package 16-pin QFN 3mm×3mm

3. Table of Contents

1. General Description	1
2. Features	1
3. Table of Contents	2
4. Block Diagram	3
5. Ordering Guide	3
6. Pin Configurations and Functions	4
■ Pin Configurations	4
■ Function	4
7. Absolute Maximum Ratings	5
8. Recommended Operating Conditions	6
9. Electrical Characteristics	6
10. Description	9
11. Recommended External Circuits	11
12. Package	12
■ Outline Dimensions	12
■ Recommended foot pattern	12
■ Marking	13
13. Revise History	14
IMPORTANT NOTICE	15

4. Block Diagram

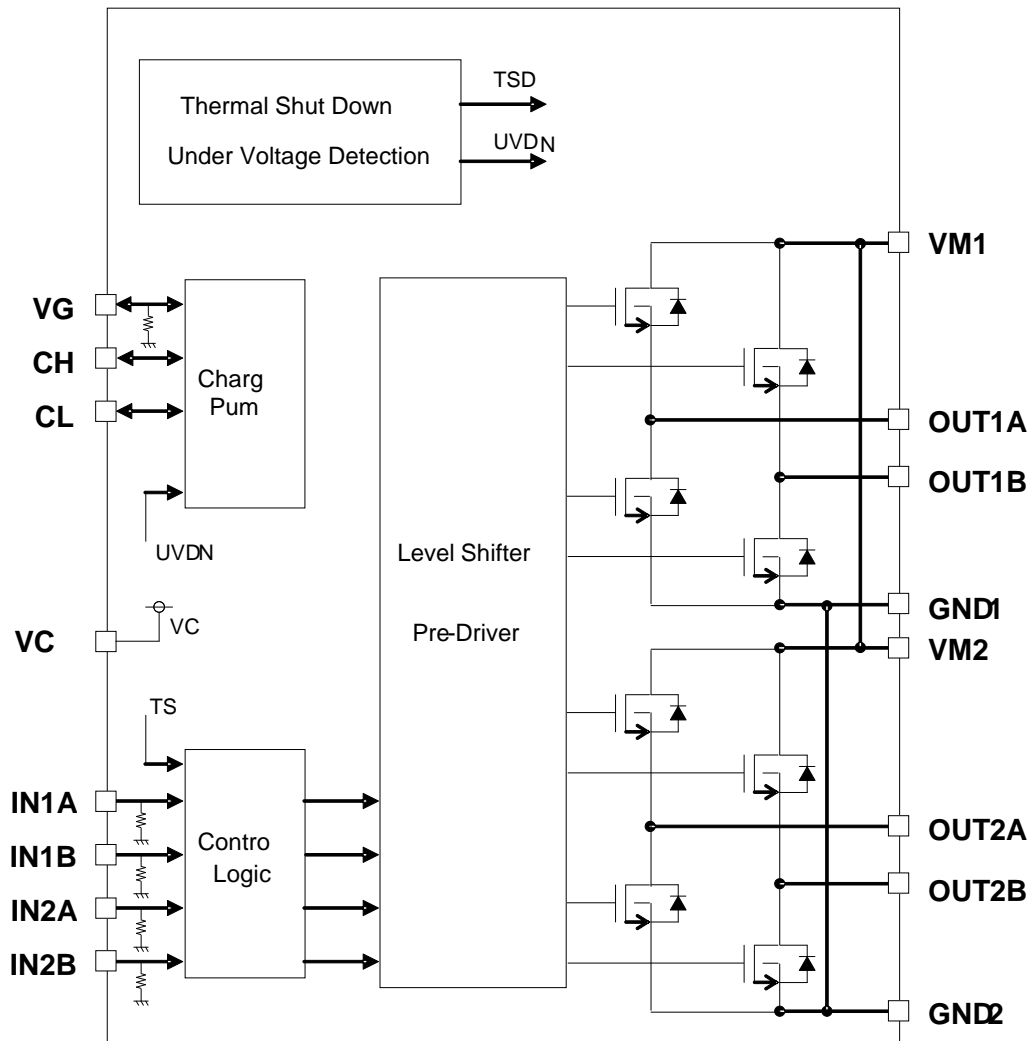

Figure 1. Block Diagram

- H-bridge driver block
NMOS type FETs are applied both high side and low side FETs of a H-bridge.
- Charge pump block
It generates the drive voltage (VG) of gate for a high side FET.
- Control logic block
Each H-bridge driver is controlled by two input signal IN1/2A or IN1/2B.
- Level shifter & pre-driver block
Control signals for the high side FET is shifted VG voltage and then drive the gate of the high side FET.
- Under Voltage Detection
It is monitoring the control voltage (VC), if the VC is less than the specified voltage, the output of the H-bridge goes to high impedance.
- Thermal Shut Down
If the temperature of the chip is more than the specified temperature, the output of the H-bridge goes to high impedance.

5. Ordering Guide

AP1016AEN -40~85°C 16-pin QFN 3mm×3mm

6. Pin Configurations and Functions

■ Pin Configurations

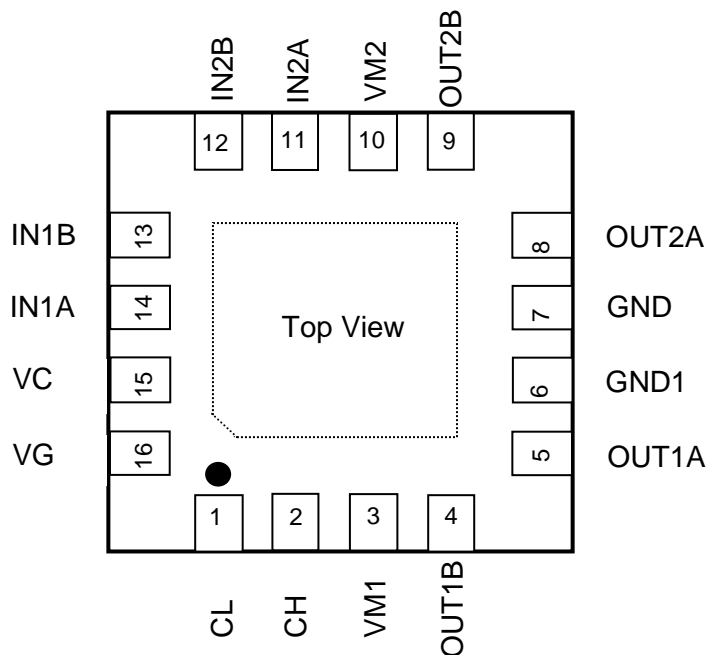

■ Function

Pin No.	Name	I/O (Note 1)	Functions	Comments
1	CL	I/O	Charge pump capacitor	
2	CH	I/O	Charge pump capacitor	
3	VM1	P	Motor driver power supply	
4	OUT1B	O	Motor driver output	CH1
5	OUT1A	O	Motor driver output	CH1
6	GND1	P	Power Ground	
7	GND2	P	Power Ground	
8	OUT2A	O	Motor driver output	CH2
9	OUT2B	O	Motor driver output	CH2
10	VM2	P	Motor driver power supply	
11	IN2A	I	Control signal input	CH2, 200kΩ (Typ) pull down
12	IN2B	I	Control signal input	CH2, 200kΩ (Typ) pull down
13	IN1B	I	Control signal input	CH1, 200kΩ (Typ) pull down
14	IN1A	I	Control signal input	CH1, 200kΩ (Typ) pull down
15	VC	P	Control circuit power supply	
16	VG	P	Charge pump output capacitor	
Exposed Pad	EP	-	Thermal pad	The pad must be connected to the ground.

Note 1. I (Input terminal), O (Output terminal) and P (Power terminal)

7. Absolute Maximum Ratings

Parameter	Symbol	min	max	Unit	Comments
Control supply voltage	VC	-0.5	6.0	V	
Motor supply voltage1	VM	-0.5	9.5	V	
VC level terminal voltage (IN1A, IN1B, IN2A and IN2B)	Vterm1	-0.5	VC	V	
VM level terminal voltage (OUT1A, OUT1B, OUT2A, OUT2B and CL)	Vterm2	-0.5	VM	V	
VC+VM level terminal voltage (CH, VG)	Vterm3	-0.5	15.5	V	
Maximum output current	Iload1	-	1.0	A	Ta=25°C
Maximum output current	Iload2	-	0.7	A	Ta=85°C
Maximum output peak current	Iload3	-	1.4	A	(Note 3)
Power dissipation	PD1	-	2.0	W	(Note 4), Ta=25°C
Power dissipation	PD2	-	1.0	W	(Note 4), Ta=85°C
Storage temperature	Tstg	-40	150	°C	

Note 2. All above voltage is defined to GND1/2=0V.

Note 3. Under 10ms in 200ms

Note 4. When the 2-layer (pattern rate: 150%) board is used. This is calculated by $R\theta J = (60)^\circ\text{C} / \text{W}$.

WARNING: Operation at or beyond these limits may result in permanent damage to the device.
Normal operation is guaranteed at these extremes.

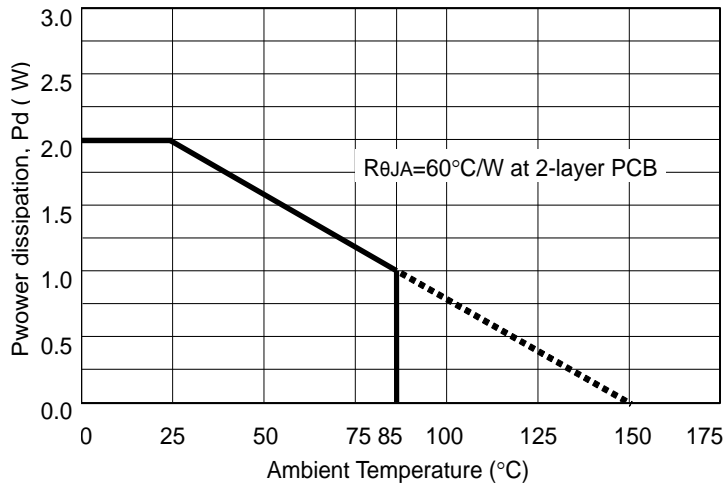

Figure 2. Maximum Power Dissipation

8. Recommended Operating Conditions

(Ta = 25°C unless otherwise specified. (Note 2))

Parameter	Symbol	min	typ	max	Unit	Comments
Motor driver supply voltage	VM	2.0	5.0	9.0	V	
Control supply voltage	VC	2.7	3.0	5.5	V	
Input pulse frequency	FIN	-	-	200	kHz	Duty=50%(input pulse)
Ambient temperature	Ta	-40	-	85	°C	
Maximum junction temperature	Tj	-	-	150	°C	

9. Electrical Characteristics

(Operating conditions; Ta = 25°C, VM=5.0V and VC = 3.0V, unless otherwise specified.,(Note 2))

Parameter	Symbol	Condition	min	typ	max	Unit
Current consumption						
VM stand by current	IVM STBY	IN1A=IN1B=IN2A= IN2B="L"		35	100	μA
VC stand by current	IVC STBY			135	400	μA
VC current	IVC	IN1A=IN2A="L" IN1B=IN2B=200kHz		500	800	μA
VM stand by current (In under voltage detection mode)	IVM UVD	VM = 5.0V VC = 0V		0.1	1.0	μA
Charge pump						
Charge pump voltage	VG	VG = VM+VC、Iload=0A			8.0	V
Charge pump wake up time (Figure 4, Figure 5)	tVGON	VC > VCUV		0.3	3.0	ms
H-bridge driver						
H-bridge driver High or Low side ON resistance	RON1	VC = 3V、Iload = 100mA Ta = 25°C		0.27	0.31	Ω
H-bridge driver High or Low side ON resistance	RON2	VC = 3V、Iload = 700mA Ta = 25°C Guaranteed by design (Note 6)		0.32	0.37	Ω
H-bridge driver High or Low side ON resistance	RON3	VC = 3V、Iload = 700mA Ta = 85°C Guaranteed by design (Note 6)		0.36	0.43	Ω
H-bridge driver Body diode forward voltage	Vf	If = 100mA		0.8	1.2	V

Parameter	Symbol	Condition	min	typ	max	Unit
Propagation delay time ("L"→"H")	tPDLH	Load=1 kΩ between OUTA and OUTB Refer to Figure 3(a) IN1A=IN2A=L IN1B=IN2B=200kHz		0.07	0.3	μs
Propagation delay time ("H"→"L")	tPDHL			0.17	0.3	μs
Propagation delay time (Hi-Z→"H")	tPDZH	(Note 5)the time from 50% input to 90% output Refer to Figure 3(c) Guaranteed by design(Note 6)		0.1	0.3	μs
Propagation delay time ("H"→ Hi-Z)	tPDHZ	(Note 5)the time from 50% input to 25% down output Refer to Figure 3(d) Guaranteed by design(Note 6)		0.1	0.3	μs
Output pulse width	tPW	Load=20kΩ between OUTA and OUTB, Input puls width=1us,Refer to Figure 3(b) Guaranteed by design (Note 6)	0.7	1.09	1.5	μs
Control logic						
Input High level voltage (IN1A, IN1B, IN2A, IN2B)	VIH	VC = 2.7V-5.5V	0.7×VC			V
Input Low level voltage (IN1A, IN1B, IN2A, IN2B)	VIL				0.3×VC	V
Input High level voltage (IN1A, IN1B, IN2A, IN2B)	IIH	Vterm1 = 3.0V	9	15	21	μA
Input Low level current (IN1A, IN1B, IN2A, IN2B)	IIIL	VC = 2.7V-5.5V	-1.0			μA
Input pulse rise time (IN1A, IN1B, IN2A, IN2B)	tr				1.0	μs
Input pulse fall time (IN1A, IN1B, IN2A, IN2B)	tf				1.0	μs
Protection functions (Figure 4 , Figure 5)						
VC low level detection voltage	VCUV		1.9	2.2	2.5	V
Voltage hysteresis	VCUVHYS	Guaranteed by design (Note 6)	0.02	0.05	0.1	V
Thermal shut down temperature	TTSD	Guaranteed by design (Note 6)	150	175	200	°C
Temperature hysteresis	TTSDHYS	Guaranteed by design (Note 6)	20	30	40	°C

Note 5. 100kΩ load resistor is connected between VM and OUTA/B, and also between OUTA/B and GND.

Note 6. Not tested in production.

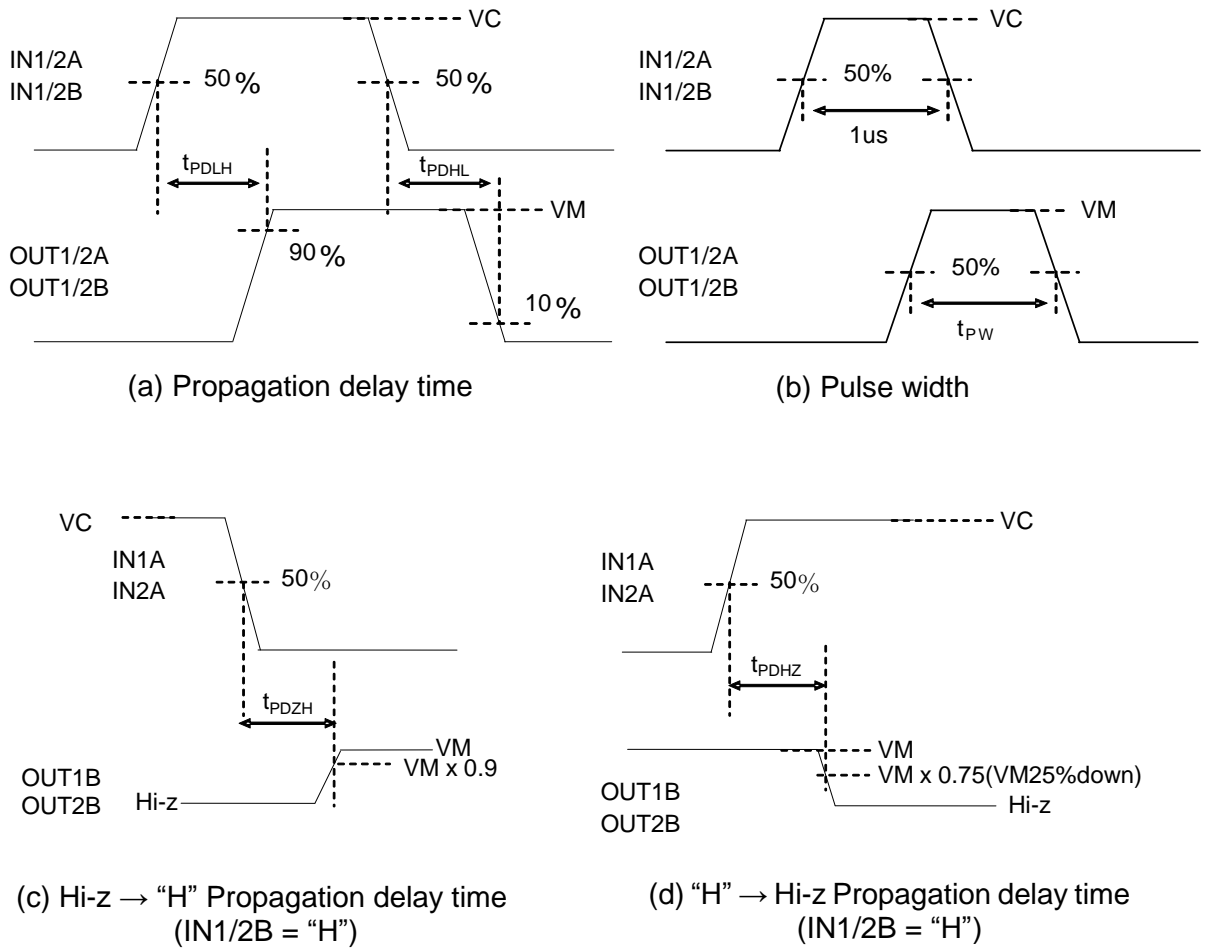

Figure 3. Time chart of propagation delay time and pulse width

10. Description

The AP1016 is suitable to drive stepper motor and voice coil motor. If the input signals are fed to IN1A, IN1B, IN2A and IN2B, the output signals, OUT1A, OUT1B, OUT2A and OUT2B are defined by table 1. The AP1016 includes Under Voltage Detection and Thermal Shut Down (TSD) circuits. The under voltage detection circuit is monitoring the control voltage (VC), if the VC is less than the specified voltage(UVD), the output of the H-bridge goes to high impedance. The thermal shut down circuit is monitoring the chip temperature. If the temperature of the chip is more than the specified temperature, the output of the H-bridge goes to high impedance. Under voltage detection and thermal shut down circuit has each hysteresis level.

Table 1. Control logic truth table (X: don't care)

Protection detection		Input		Output		Motion (Note 7)
UVDN	TSD	IN1A IN2A	IN1B IN2B	OUT1A OUT2A	OUT1B OUT2B	
H	L	L	L	L	L	Brake
H	L	H	L	H	L	Forward (CW)
H	L	L	H	L	H	Reverse (CCW)
H	L	H	H	Hi-Z	Hi-Z	Standby
H	H	X	X			
L	X	X	X			

Note 7. Direction of Current

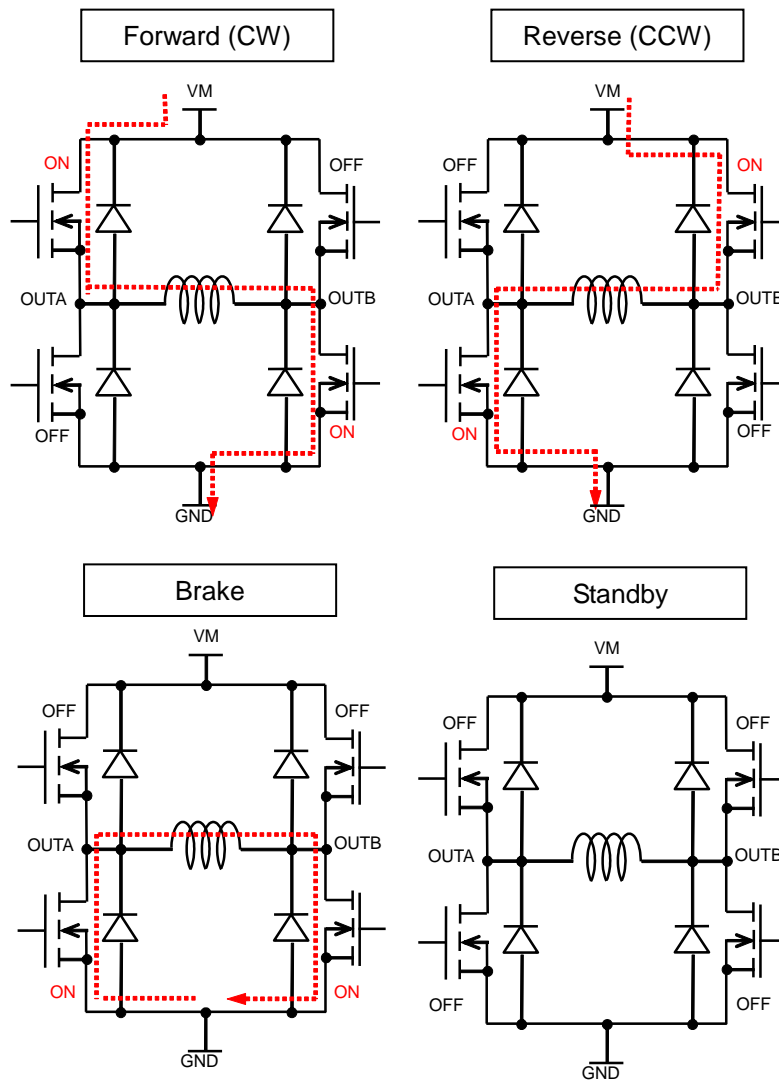

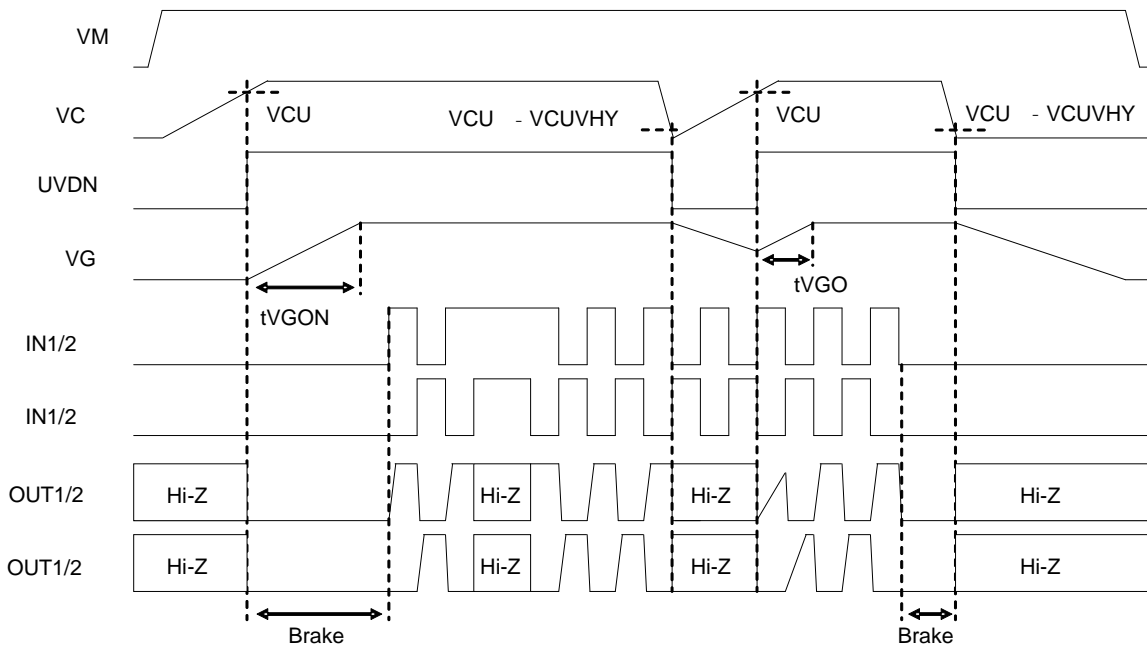

Figure 4. Time chart of input and output (in case of VDUV detection)

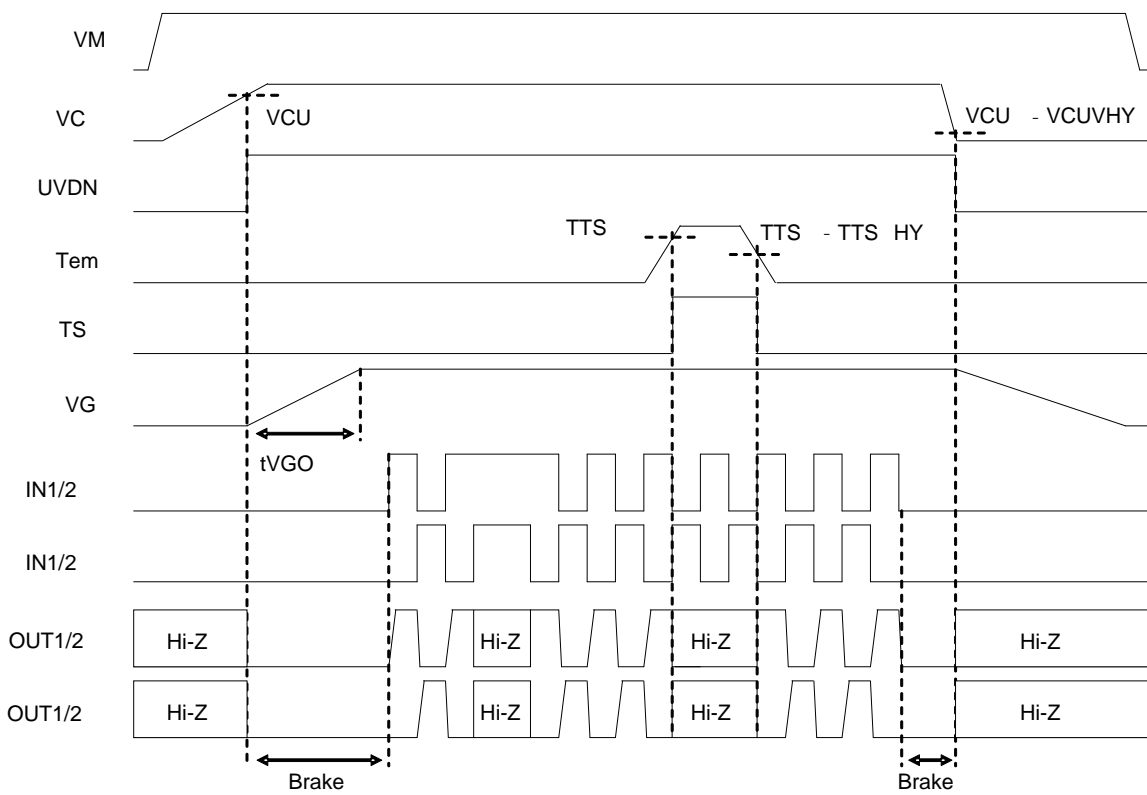

Figure 5. Time chart of input and output (in case of TSD detection)

11. Recommended External Circuits

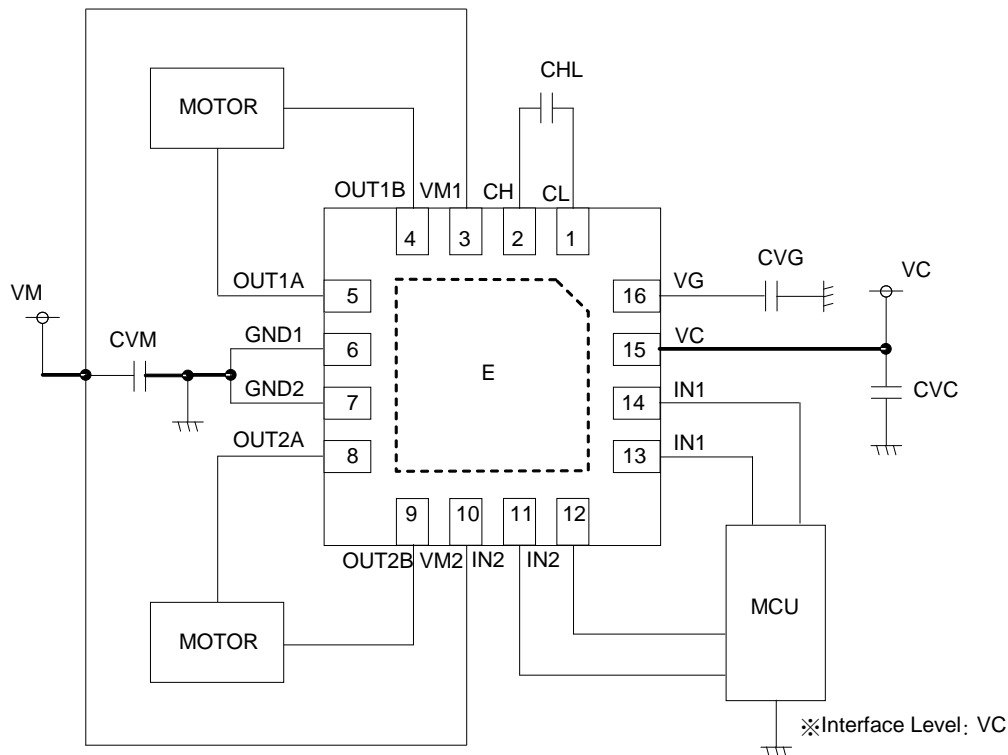

Figure 6. Recommended External Circuits (Top view)

Table 2. Recommended external components example

Parameter	Symbol	min	typ	max	Unit	Condition
Motor driver power supply connection decoupling capacitor	CVM	-	1	-	μF	(Note 8)
Control power supply connection bypass capacitor	CVC	-	0.1	-	μF	(Note 8)
Charge pump capacitance1	CVG	0.047	0.1	0.22	μF	
Charge pump capacitance2	CHL	0.047	0.1	0.22	μF	

Note 8. Please adjust the connecting capacitor of CVM and CVC depending on the load current profile, the load capacitance, the line resistance and etc. with each application boards.

12. Package

■ **Outline Dimensions**

(Unit: mm)

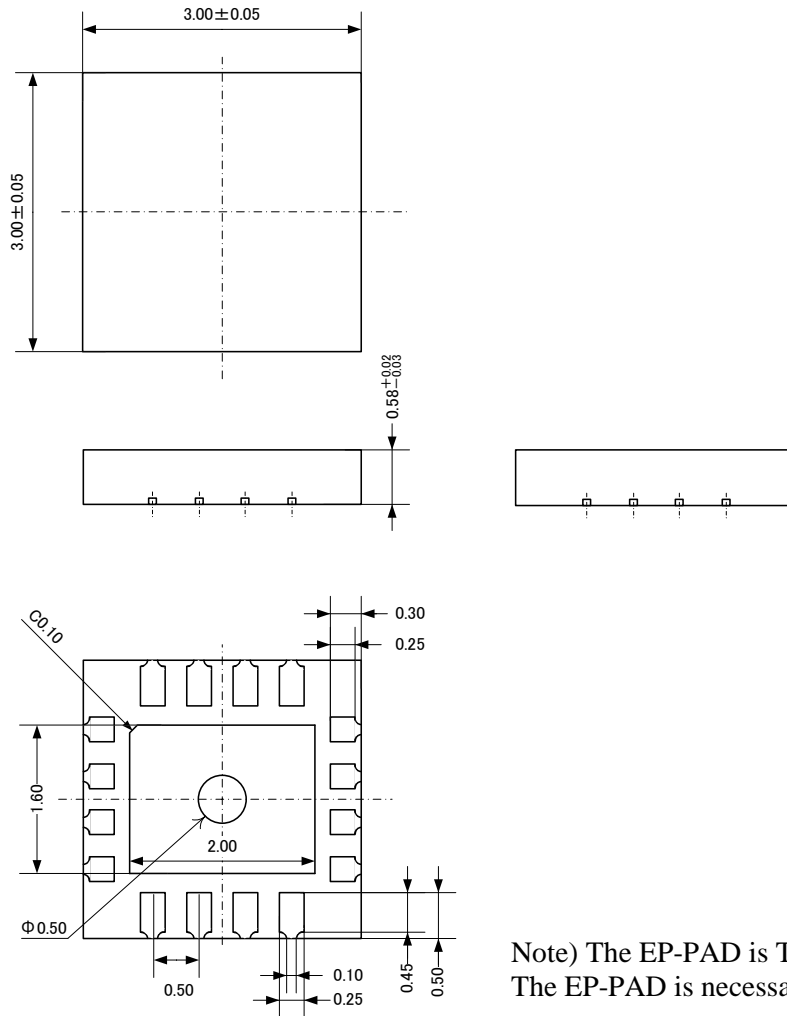

Note) The EP-PAD is Thermal Pad.
The EP-PAD is necessary soldered to PCB.

■ **Recommended foot pattern**

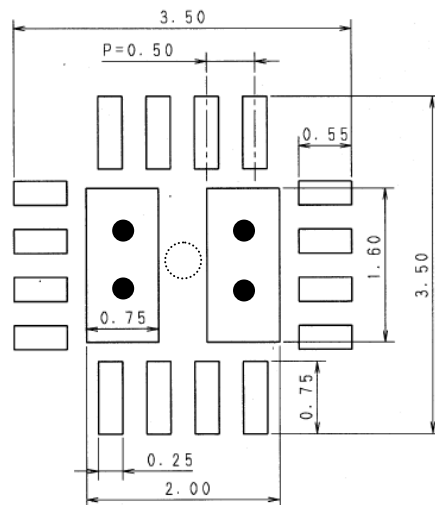

Note)
Please layout the foot pattern of EP-PAD not to surround the steam via of AP1016. Please locate thermal via for radiation improvement more than four halls.

- : example of steam via
- : example of thermal via

■ **Marking**

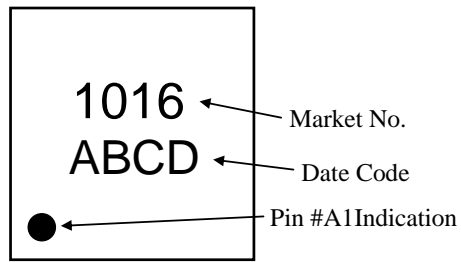

YWWA: Date code (4 digit)

A: Manage number

WW: Producing week

Y: Producing year (Ex: 2013 → “3”)

13. Revise History

Date (YY/MM/DD)	Revision	Page	Contents
14/01/31	00		First edition
14/08/07	01	7	Propagation delay time (Hi-z →“H”, “H”→Hi-z)Condition “the time from 50% to 75% output” → “the time from 50% input to 90% output” “the time from 75% to 50% output” → “the time from 50% input to 90% output” Propagation delay time (“H”→Hi-Z) typ 0.15μs → typ 0.1μs
		8	Figure 3 Time chart of propagation Hi-z →“H” and “H”→Hi-z were added.
14/10/09	02	9	Figure of direction of current was corrected.
14/12/24	03	3	Correct temperature range in ordering guide

IMPORTANT NOTICE

0. Asahi Kasei Microdevices Corporation (“AKM”) reserves the right to make changes to the information contained in this document without notice. When you consider any use or application of AKM product stipulated in this document (“Product”), please make inquiries the sales office of AKM or authorized distributors as to current status of the Products.
1. All information included in this document are provided only to illustrate the operation and application examples of AKM Products. AKM neither makes warranties or representations with respect to the accuracy or completeness of the information contained in this document nor grants any license to any intellectual property rights or any other rights of AKM or any third party with respect to the information in this document. You are fully responsible for use of such information contained in this document in your product design or applications. **AKM ASSUMES NO LIABILITY FOR ANY LOSSES INCURRED BY YOU OR THIRD PARTIES ARISING FROM THE USE OF SUCH INFORMATION IN YOUR PRODUCT DESIGN OR APPLICATIONS.**
2. The Product is neither intended nor warranted for use in equipment or systems that require extraordinarily high levels of quality and/or reliability and/or a malfunction or failure of which may cause loss of human life, bodily injury, serious property damage or serious public impact, including but not limited to, equipment used in nuclear facilities, equipment used in the aerospace industry, medical equipment, equipment used for automobiles, trains, ships and other transportation, traffic signaling equipment, equipment used to control combustions or explosions, safety devices, elevators and escalators, devices related to electric power, and equipment used in finance-related fields. Do not use Product for the above use unless specifically agreed by AKM in writing.
3. Though AKM works continually to improve the Product’s quality and reliability, you are responsible for complying with safety standards and for providing adequate designs and safeguards for your hardware, software and systems which minimize risk and avoid situations in which a malfunction or failure of the Product could cause loss of human life, bodily injury or damage to property, including data loss or corruption.
4. Do not use or otherwise make available the Product or related technology or any information contained in this document for any military purposes, including without limitation, for the design, development, use, stockpiling or manufacturing of nuclear, chemical, or biological weapons or missile technology products (mass destruction weapons). When exporting the Products or related technology or any information contained in this document, you should comply with the applicable export control laws and regulations and follow the procedures required by such laws and regulations. The Products and related technology may not be used for or incorporated into any products or systems whose manufacture, use, or sale is prohibited under any applicable domestic or foreign laws or regulations.
5. Please contact AKM sales representative for details as to environmental matters such as the RoHS compatibility of the Product. Please use the Product in compliance with all applicable laws and regulations that regulate the inclusion or use of controlled substances, including without limitation, the EU RoHS Directive. AKM assumes no liability for damages or losses occurring as a result of noncompliance with applicable laws and regulations.
6. Resale of the Product with provisions different from the statement and/or technical features set forth in this document shall immediately void any warranty granted by AKM for the Product and shall not create or extend in any manner whatsoever, any liability of AKM.
7. This document may not be reproduced or duplicated, in any form, in whole or in part, without prior written consent of AKM.

Looking for pricing, stock, or lifecycle information?

Click below to explore more details on WIN SOURCE:

- ⊖ [View AP1016AEN](#) on WIN SOURCE
- ⊖ [Asahi Kasei Microsystems](#) Information

Optimize Your Supply Chain with WIN SOURCE Solutions

- ✓ Global Sourcing Solution
- ✓ Obsolete Management
- ✓ Cost Control Management
- ✓ Shortage Management
- ✓ Alternative Solution
- ✓ Excess Inventory Management