



**THE DATASHEET OF
BD3925FP-CE2**



Voltage Tracker

BD3925FP-C BD3925HFP-C

General Description

BD3925FP-C and BD3925HFP-C are voltage trackers for automotive use which have high withstand-voltage of up to 50V. They offer an output current loading of up to 500mA while limiting the quiescent current to 45µA (Typ).

BD3925FP-C and BD3925HFP-C are suited for systems that are permanently connected to the car battery and require low-current-consumption. The offset is ±10mV (for 5V output, 6V < V_{CC} < 36V, 5mA < I_{OUT} < 200mA). They integrate folded-type over-current protection to minimize heat dissipation when accidentally shorted, thus offering the most robust power-supply design under harsh automotive environment.

Features

- Low-Saturation Voltage Type P-Channel DMOS Output Transistors
- Low Offset Voltage: ± 10mV(for 5V Output, 6V < V_{CC} < 36V, 5mA < I_{OUT} < 200mA)
- VCC Power Supply Voltage = 50 V
- Integrated Over-Current Protection Circuit and Thermal Shutdown Circuit

Applications

Onboard vehicle devices (body-control, car stereos, satellite navigation systems, etc.)

Key Specifications

- Input Supply Voltage Range: 4.5V to 36V
- Ultra-Low Quiescent Current: 45µA (Typ)
- Operating Temperature Range: -40°C to +125°C

Packages

W(Typ) x D(Typ) x H(Max)



TO252-5

6.50mm x 9.50mm x 2.50mm



HRP5

9.395mm x 10.540mm x 2.005mm

Ordering Information

B D 3 9 2 5 x x x - C x x

Part Number

Package

HFP :HRP5

FP :TO252-5

Packaging and forming specification

TR: Embossed tape and reel (HRP5)

E2: Embossed tape and reel (TO252-5)

Lineup

Package		Orderable Part Number
TO252-5	Reel of 2000	BD3925FP-CE2
HRP5	Reel of 2000	BD3925HFP-CTR

Block Diagrams

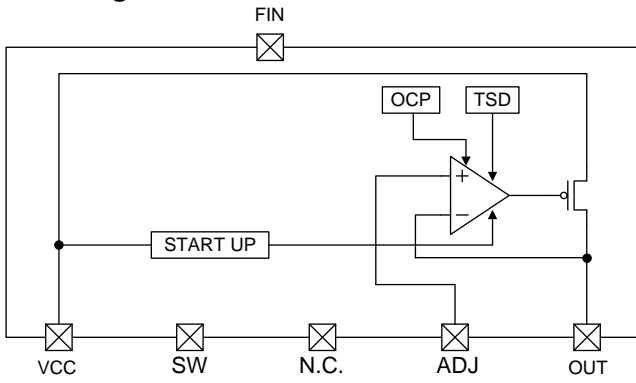

Figure 1. (FP)

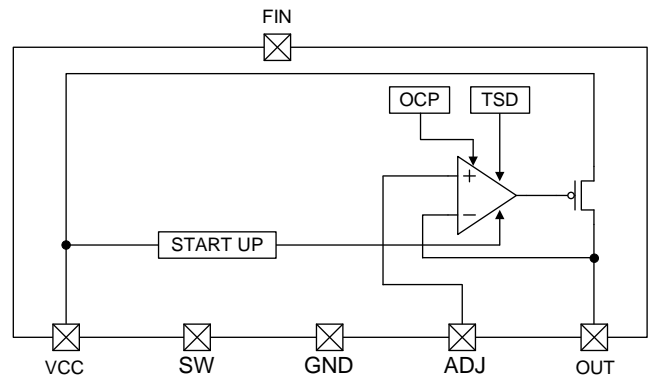
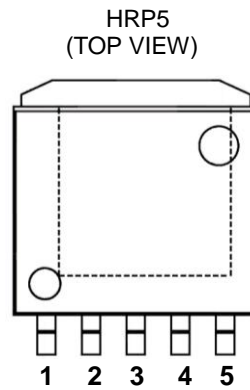
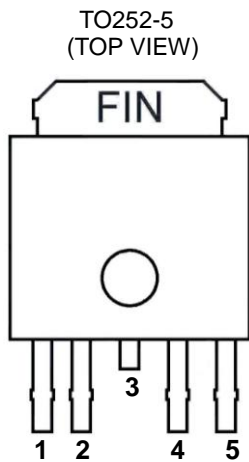

Figure 2. (HFP)

Pin Configurations



Pin Descriptions

TO252-5

Pin No.	Pin Name	Function
1	VCC	Power supply pin
2	SW	OUT ON/OFF function pin
3	N.C.	No connection
4	ADJ	Input voltage
5	OUT	Output voltage
FIN	GND	Ground

HRP5

Pin No.	Pin Name	Function
1	VCC	Power supply pin
2	SW	OUT ON/OFF function pin
3	GND	Ground
4	ADJ	Input voltage
5	OUT	Output voltage
FIN	GND	Ground

Absolute Maximum Ratings (Ta=25°C)

Parameter	Symbol	Limit	Unit
Supply Voltage	V _{CC}	50 ^(Note 1)	V
Switch Supply Voltage	V _{SW}	50	V
V _{ADJ} Terminal Supply Voltage	V _{ADJ}	28	V
OUT Terminal Voltage	V _{OUT}	28	V
Output Current	I _{OUT}	500	mA
Power Dissipation	Pd	1.3 (TO252-5) ^(Note 2)	W
		1.6 (HRP5) ^(Note 3)	
Operating Temperature Range	Topr	-40 to +125	°C
Storage Temperature Range	Tstg	-55 to +150	°C
Maximum Junction Temperature	Tjmax	150	°C

(Note 1) Not to exceed Pd.

(Note 2) TO252-5: Reduced by 10.4mW/°C over 25°C, when mount on a glass epoxy board: 70 mm x 70 mm x 1.6 mm.

(Note 3) HRP5: Reduced by 12.8mW/°C over 25°C, when mount on a glass epoxy board: 70 mm x 70 mm x 1.6 mm.

Caution: Operating the IC over the absolute maximum ratings may damage the IC. The damage can either be a short circuit between pins or an open circuit between pins and the internal circuitry. Therefore, it is important to consider circuit protection measures such as adding a fuse, in case the IC is operated over the absolute maximum ratings

Recommended Operating Conditions

Parameter	Symbol	Min	Max	Unit
Supply Voltage	V _{CC}	4.5 ^(Note 4)	36.0	V
Input Voltage ^(Note 5)	V _{ADJ}	2.5	14	V
Output Current	I _{OUT}	-	500	mA

(Note 4) Please consider that the Output voltage would drop (Dropout voltage) according to the output current.

(Note 5) Not to exceed V_{CC} - 0.5V.

Electrical Characteristics (Unless otherwise specified, Ta=-40°C to +125°C, V_{CC}=13.2 V, V_{SW}=3V, V_{ADJ}=5V)

Parameter	Symbol	Min	Typ	Max	Unit	Conditions
Standby Current	I _{STBY}	-	-	10	μA	SW=GND
Circuit Current	I _{CC}	-	45	90	μA	I _{OUT} =0mA
Offset Voltage	ΔV _{OUT}	-10	-	+10	mV	6V<V _{CC} <36V, 5mA<I _{OUT} <200mA
Output Current	I _{OUT}	0.5	-	-	A	
Dropout Voltage	ΔV _D	-	0.25	0.48	V	V _{CC} =5V, V _{ADJ} =5V, I _{OUT} =200mA
Ripple Rejection	R.R.	45	55	-	dB	f=120Hz, ein=1V _{RMS} , I _{OUT} =100mA
Switch Threshold Voltage H	V _{SWH}	2.0	-	-	V	Active Mode
Switch Threshold Voltage L	V _{SWL}	-	-	0.5	V	OFF Mode
Switch Bias Current	I _{SWI}	-	22	60	μA	V _{SW} =5V
ADJ Bias Current	I _{ADJ}	-	5	12	μA	V _{ADJ} =5V

Typical Performance Curves

BD3925FP-C (Unless otherwise specified, $V_{CC}=13.2V$, $V_{ADJ}=5V$, $V_{SW}=3V$, $T_a=25^{\circ}C$)

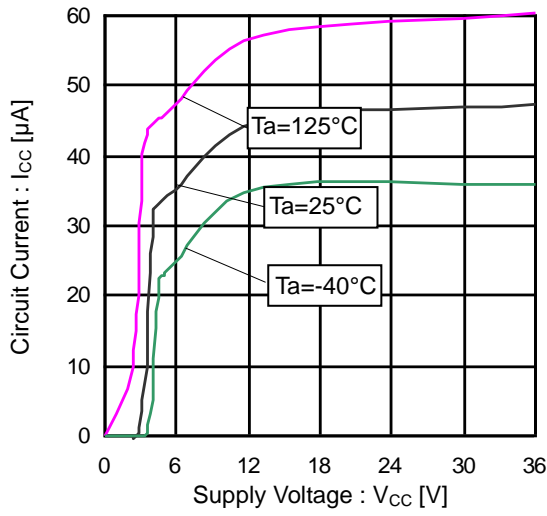

Figure 3. Circuit Current vs Supply Voltage

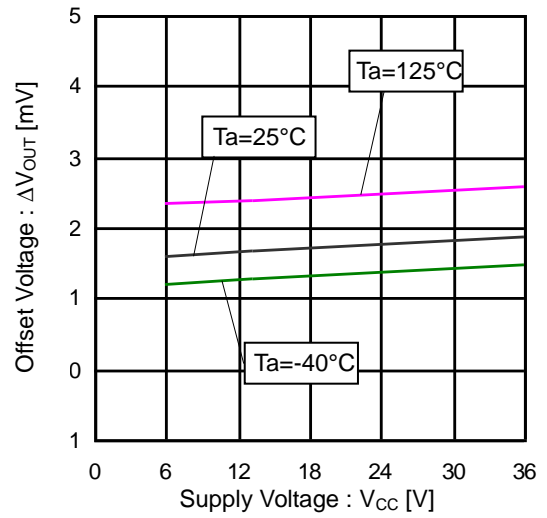

Figure 4. Offset Voltage vs Supply Voltage1 ($I_{OUT}=5mA$)

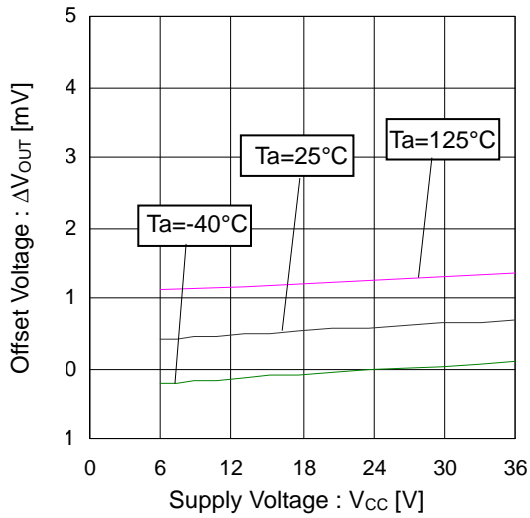

Figure 5. Offset Voltage vs Supply Voltage 2 ($I_{OUT}=200mA$)

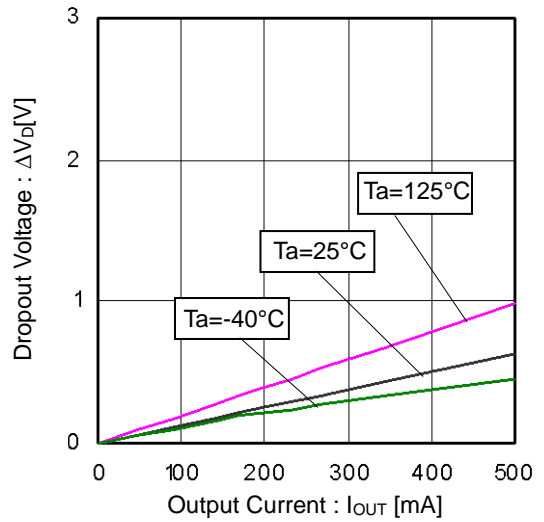

Figure 6. Dropout Voltage vs Output Current

Typical Performance Curves – continued

Unless otherwise specified, $V_{CC}=13.2V$, $V_{ADJ}=5V$, $V_{SW}=3V$, $T_a=25^\circ C$

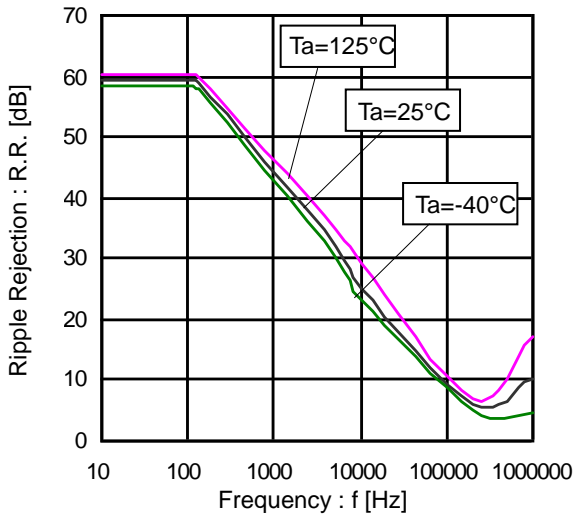

Figure 7. Ripple Rejection vs Frequency

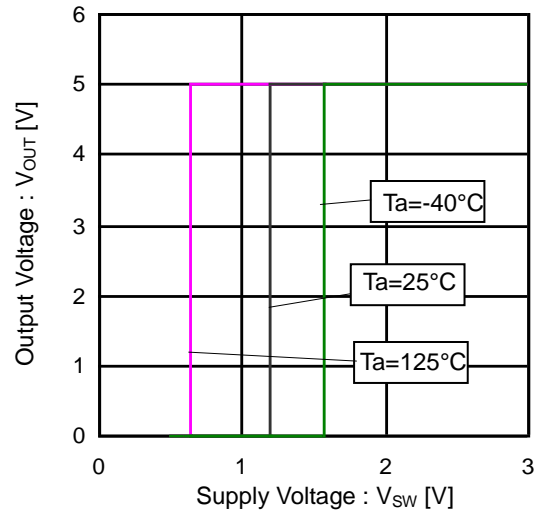

Figure 8. Output Voltage vs SW Input Voltage

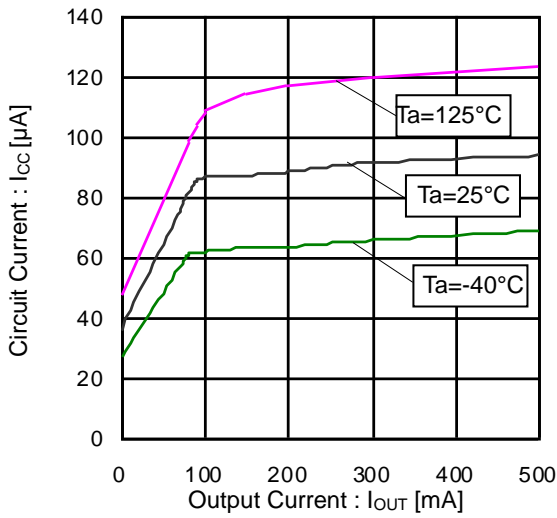

Figure 9. Circuit Current vs Output Current (Circuit Current Classified by Load)

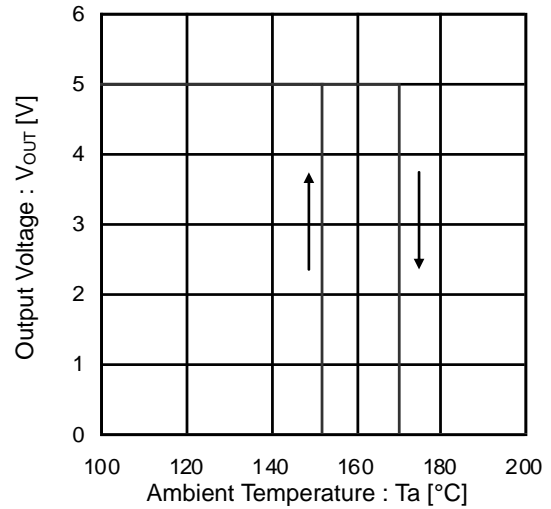

Figure 10. Output Voltage vs Ambient Temperature (Thermal Shutdown Circuit)

Typical Performance Curves – continued

Unless otherwise specified, $V_{CC}=13.2V$, $V_{ADJ}=5V$, $V_{SW}=3V$, $T_a=25^\circ C$

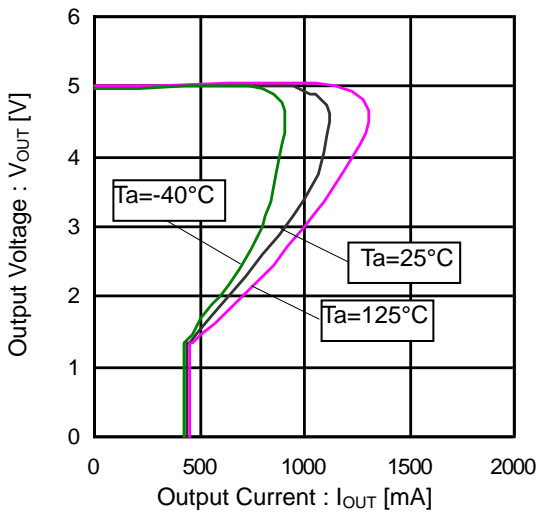

Figure 11. Output Voltage vs Output Current

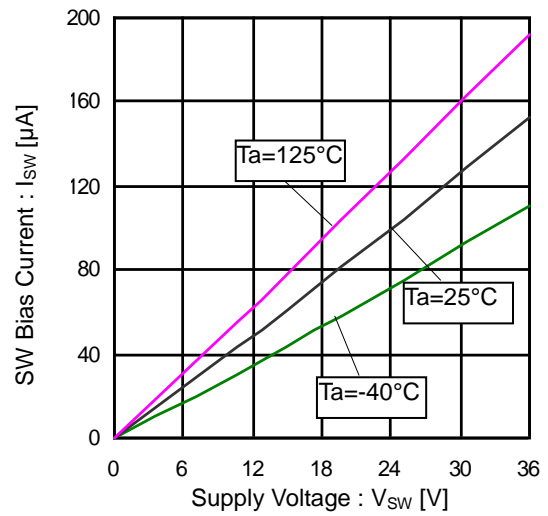

Figure 12. SW Bias Current vs Supply Voltage

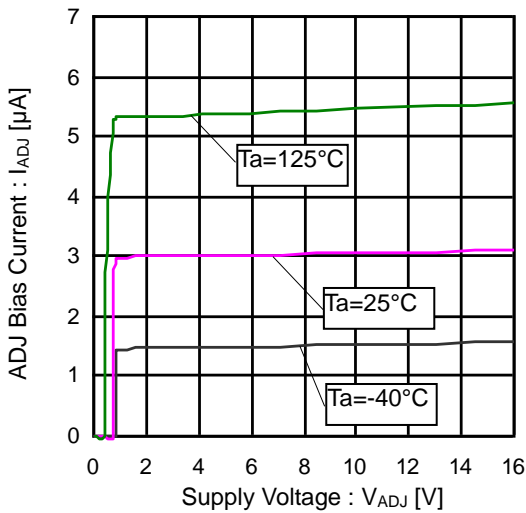

Figure 13. ADJ Bias Current vs Supply Voltage

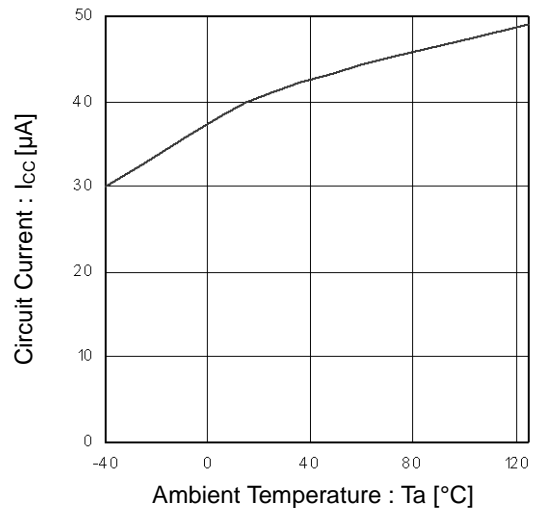
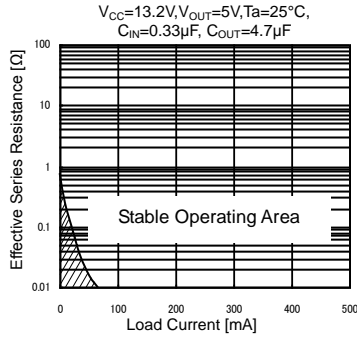

Figure 14. Circuit Current vs Temperature

Pin Settings / Precautions

- VCC Pins**
 Insert capacitors with a capacitance of 0.33μF to 1000μF between the VCC and GND pins.
 The capacitance varies with the application. Be sure to design the capacitance with a sufficient margin.
- Output Pin**
 It is necessary to place capacitors between each output pin and GND to prevent oscillation on the output. Usable capacitance values range from 4.7μF to 1000μF. Ceramic capacitors can be used as long as their ESR value is low enough to prevent oscillation. Abrupt fluctuations in input voltage and load conditions may affect the output voltage. Output capacitance values should be determined only through sufficient testing of the actual application.



Effective Series Resistance vs Load Current (Reference Data)

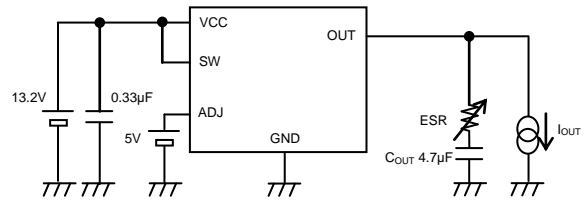

Note: Measurement Circuit (Reference Data)

Power Dissipation

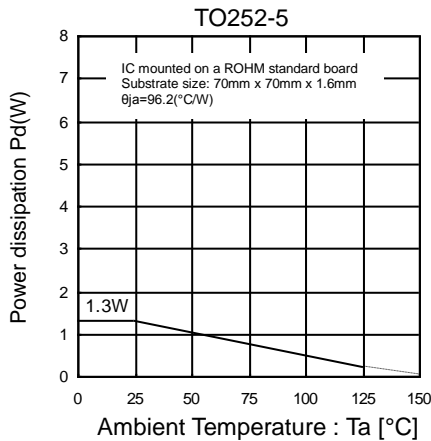

Figure 15

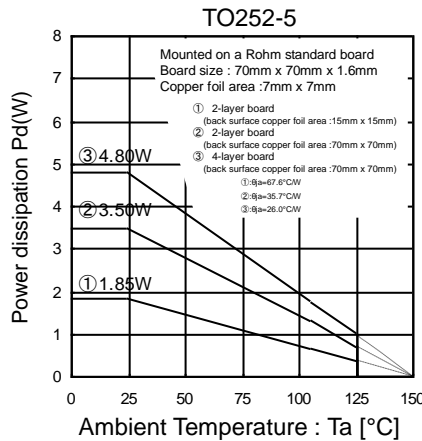

Figure 16

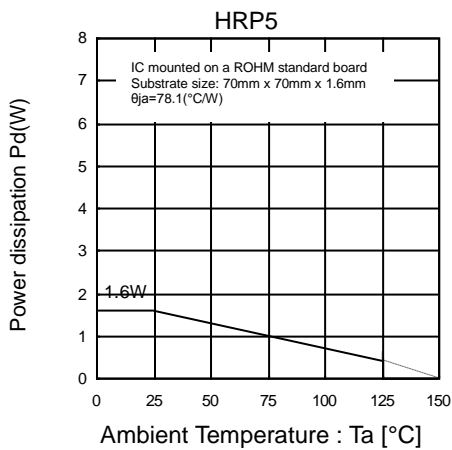

Figure 17

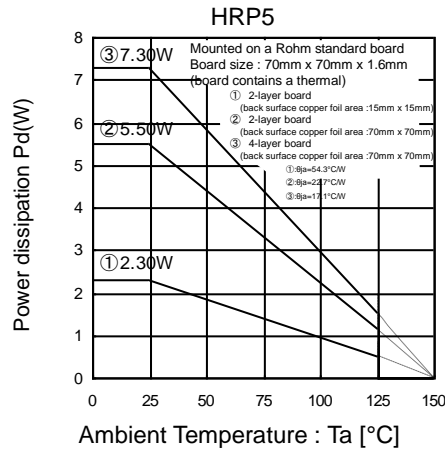

Figure 18

Refer to the heat attenuation characteristics illustrated in Figure 15 to Figure 18 when using the IC in an environment where Ta exceeds 25°C. The operating temperature of the IC greatly influences the characteristics of the IC. If the temperature exceeds the maximum junction temperature Tjmax, the elements of the IC may be deteriorated or damaged. It is necessary to give sufficient consideration to the heat of the IC in view of two points, i.e., the protection of the IC from instantaneous damage and the maintenance of the reliability of the IC in long-time operation.

In order to protect the IC from thermal destruction, it is necessary to operate the IC below the maximum junction temperature (Tjmax) Figure 15 and Figure 16 illustrate the power dissipation/heat attenuation characteristics for the TO252 package. Operate the IC within the power dissipation Pd. The following method is used to calculate the power consumption Pc (W).

$$Pc = (V_{CC} - V_{OUT}) \times I_{OUT} + V_{CC} \times I_{CC}$$

Power dissipation Pd ≥ Pc

where:

V_{CC} is the Input Voltage

V_{OUT} is the Output Voltage

I_{OUT} is the Load Current

I_{CC} is the Total Supply Current

The load current I_{OUT} is obtained to operate the IC within the power dissipation.

$$I_{OUT} \leq \frac{Pd - V_{CC} \times I_{CC}}{V_{CC} - V_{OUT}} \quad (\text{Please refer to Figure 9. and Figure 14. for } I_{CC}.)$$

The maximum load current I_{OMAX} for the applied voltage V_{CC} can be calculated during the thermal design process.

Example: BD3925FP-C V_{CC} = 12V and V_{OUT}=5V(ADJ=5) at Ta = 85°C

$$I_{OUT} \leq \frac{2.496 - 12 \times I_{CC}}{12 - 5} \quad \left(\begin{array}{l} \text{Figure 16 } \textcircled{3} : \theta_{ja} = 26.0^\circ\text{C/W to } -38.4\text{mAW}/^\circ\text{C} \\ 25^\circ\text{C} = 4.80\text{W to } 85^\circ\text{C} = 2.496\text{W} \end{array} \right)$$

$$I_{OUT} \leq 356\text{mA} \quad (I_{CC} = 100\mu\text{A})$$

Make a thermal calculation with the consideration above so that the whole operating temperature range will be within the power dissipation.

The power consumption Pc of the IC in the event of shorting (i.e., if the OUT and GND pins are shorted) will be obtained from the following equation.

$$Pc = V_{CC} \times (I_{CC} + I_{short}) \quad (\text{Please refer to Figure 11. for } I_{short}.)$$

where:

I_{short} is the Short current

I/O Equivalent Circuits (All Resistance Values are Typical)

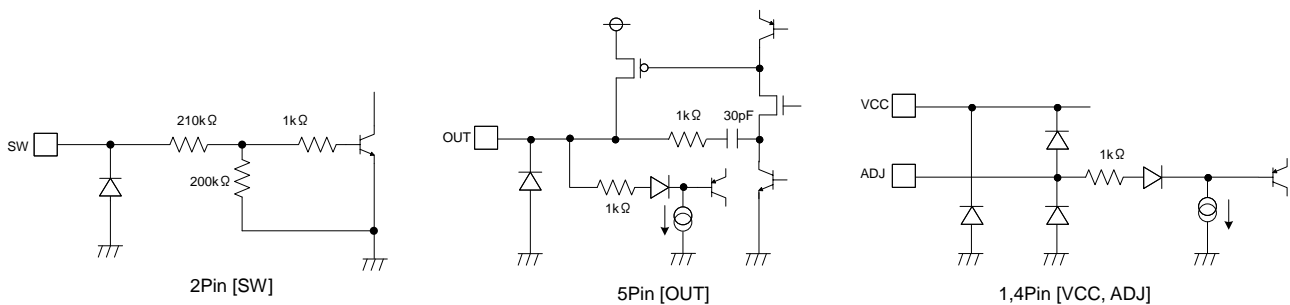

Operational Notes

1. Reverse Connection of Power Supply

Connecting the power supply in reverse polarity can damage the IC. Take precautions against reverse polarity when connecting the power supply, such as mounting an external diode between the power supply and the IC's power supply pins.

2. Power Supply Lines

Design the PCB layout pattern to provide low impedance supply lines. Separate the ground and supply lines of the digital and analog blocks to prevent noise in the ground and supply lines of the digital block from affecting the analog block. Furthermore, connect a capacitor to ground at all power supply pins. Consider the effect of temperature and aging on the capacitance value when using electrolytic capacitors.

3. Ground Voltage

Ensure that no pins are at a voltage below that of the ground pin at any time, even during transient condition.

4. Ground Wiring Pattern

When using both small-signal and large-current ground traces, the two ground traces should be routed separately but connected to a single ground at the reference point of the application board to avoid fluctuations in the small-signal ground caused by large currents. Also ensure that the ground traces of external components do not cause variations on the ground voltage. The ground lines must be as short and thick as possible to reduce line impedance.

5. Thermal Consideration

Should by any chance the power dissipation rating be exceeded the rise in temperature of the chip may result in deterioration of the properties of the chip. The absolute maximum rating of the Pd stated in this specification is when the IC is mounted on a 70mm x 70mm x 1.6mm glass epoxy board. In case of exceeding this absolute maximum rating, increase the board size and copper area to prevent exceeding the Pd rating.

6. Recommended Operating Conditions

These conditions represent a range within which the expected characteristics of the IC can be approximately obtained. The electrical characteristics are guaranteed under the conditions of each parameter.

7. Inrush Current

When power is first supplied to the IC, it is possible that the internal logic may be unstable and inrush current may flow instantaneously due to the internal powering sequence and delays, especially if the IC has more than one power supply. Therefore, give special consideration to power coupling capacitance, power wiring, width of ground wiring, and routing of connections.

8. Testing on Application Boards

When testing the IC on an application board, connecting a capacitor directly to a low-impedance output pin may subject the IC to stress. Always discharge capacitors completely after each process or step. The IC's power supply should always be turned off completely before connecting or removing it from the test setup during the inspection process. To prevent damage from static discharge, ground the IC during assembly and use similar precautions during transport and storage.

9. Inter-pin Short and Mounting Errors

Ensure that the direction and position are correct when mounting the IC on the PCB. Incorrect mounting may result in damaging the IC. Avoid nearby pins being shorted to each other especially to ground, power supply and output pin. Inter-pin shorts could be due to many reasons such as metal particles, water droplets (in very humid environment) and unintentional solder bridge deposited in between pins during assembly to name a few.

Operational Notes – continued

10. Unused Input Pins

Input pins of an IC are often connected to the gate of a MOS transistor. The gate has extremely high impedance and extremely low capacitance. If left unconnected, the electric field from the outside can easily charge it. The small charge acquired in this way is enough to produce a significant effect on the conduction through the transistor and cause unexpected operation of the IC. So unless otherwise specified, unused input pins should be connected to the power supply or ground line.

11. Regarding the Input Pin of the IC

This monolithic IC contains P+ isolation and P substrate layers between adjacent elements in order to keep them isolated. P-N junctions are formed at the intersection of the P layers with the N layers of other elements, creating a parasitic diode or transistor. For example (refer to figure below):

When GND > Pin A and GND > Pin B, the P-N junction operates as a parasitic diode.
 When GND > Pin B, the P-N junction operates as a parasitic transistor.

Parasitic diodes inevitably occur in the structure of the IC. The operation of parasitic diodes can result in mutual interference among circuits, operational faults, or physical damage. Therefore, conditions that cause these diodes to operate, such as applying a voltage lower than the GND voltage to an input pin (and thus to the P substrate) should be avoided.

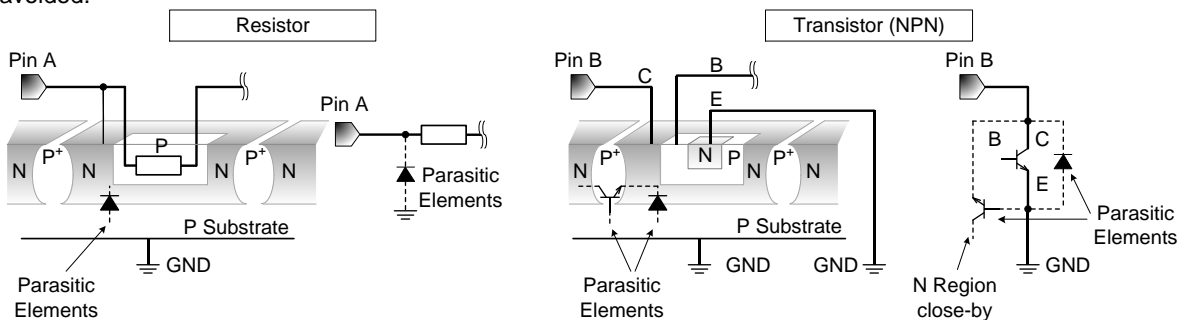

Figure 19. Example of monolithic IC structure

12. Thermal Shutdown Circuit(TSD)

This IC has a built-in thermal shutdown circuit that prevents heat damage to the IC. Normal operation should always be within the IC's power dissipation rating. If however the rating is exceeded for a continued period, the junction temperature (Tj) will rise which will activate the TSD circuit that will turn OFF all output pins. When the Tj falls below the TSD threshold, the circuits are automatically restored to normal operation.

Note that the TSD circuit operates in a situation that exceeds the absolute maximum ratings and therefore, under no circumstances, should the TSD circuit be used in a set design or for any purpose other than protecting the IC from heat damage.

TSD ON temperature [°C] (typ)	Hysteresis temperature [°C] (typ)
175	25

13. Over Current Protection Circuit (OCP)

This IC incorporates an integrated overcurrent protection circuit that is activated when the load is shorted. This protection circuit is effective in preventing damage due to sudden and unexpected incidents. However, the IC should not be used in applications characterized by continuous operation or transitioning of the protection circuit.

14. Applications or inspection processes where the potentials of the VCC pin and other pins may be reversed from their normal states may cause damage to the IC's internal circuitry or elements. Use an output pin capacitance of 470µF or lower in case VCC is shorted with the GND pin while the external capacitor is charged. It is recommended to insert a diode for preventing back current flow in series with VCC or bypass diodes between VCC and each pin.

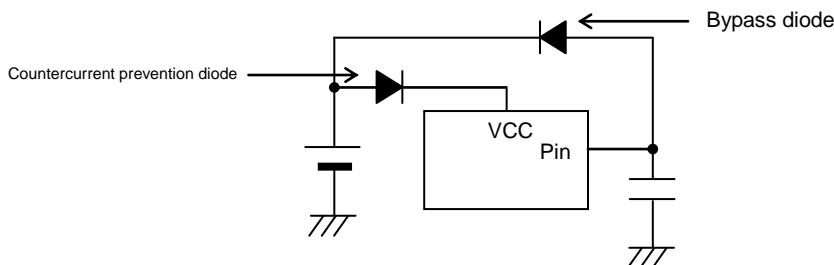

15. SW Pin, ADJ Pin

Do not apply the voltage to SW pin and ADJ pin when the VCC is not applied.
 And when the VCC is applied, the voltage of SW pin and ADJ pin must not exceed VCC.

Operational Notes – continued

16. About Positive Surge Voltage

To protect against a surge voltage that exceeds 50V between VCC and GND please insert a power zener diode between VCC terminal and GND.

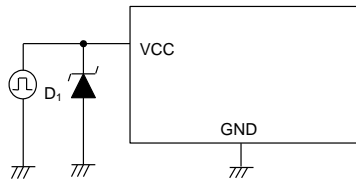

17. Negative Voltage Surges on VCC Pin

A schottky barrier diode should be inserted between VCC and GND for protection against voltages lower than GND at the VCC pin.

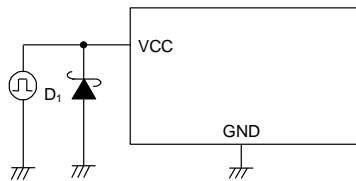

18. For Very Small Fluctuations of Output Voltage

When the application is used where very small fluctuations of output voltage caused by some factors (e.g. disturbance noise, input voltage fluctuations, load fluctuations, etc.), please take enough measures to avoid some influence (e.g. insert the filter, etc.).

19. Output Protection Diode

Output loads with large inductive component may cause reverse current flow to the output pin during startup or shutdown. In such cases, a protection diode should be inserted at the output to protect the IC.

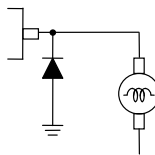

Marking Diagrams

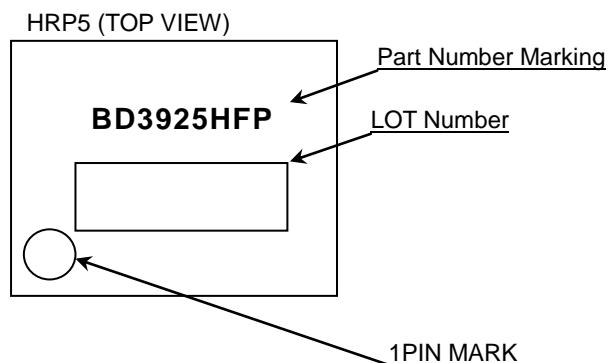
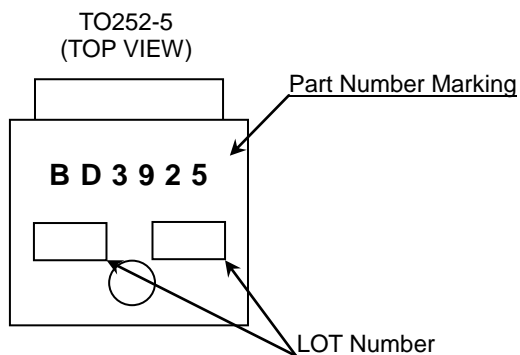

Part Number Marking	Package		Part Number
BD3925	TO252-5	Reel of 2000	BD3925FP-CE2
BD3925HFP	HRP5	Reel of 2000	BD3925HFP-CTR

Physical Dimensions, Tape and Reel Information

Package Name	TO252-5
--------------	---------

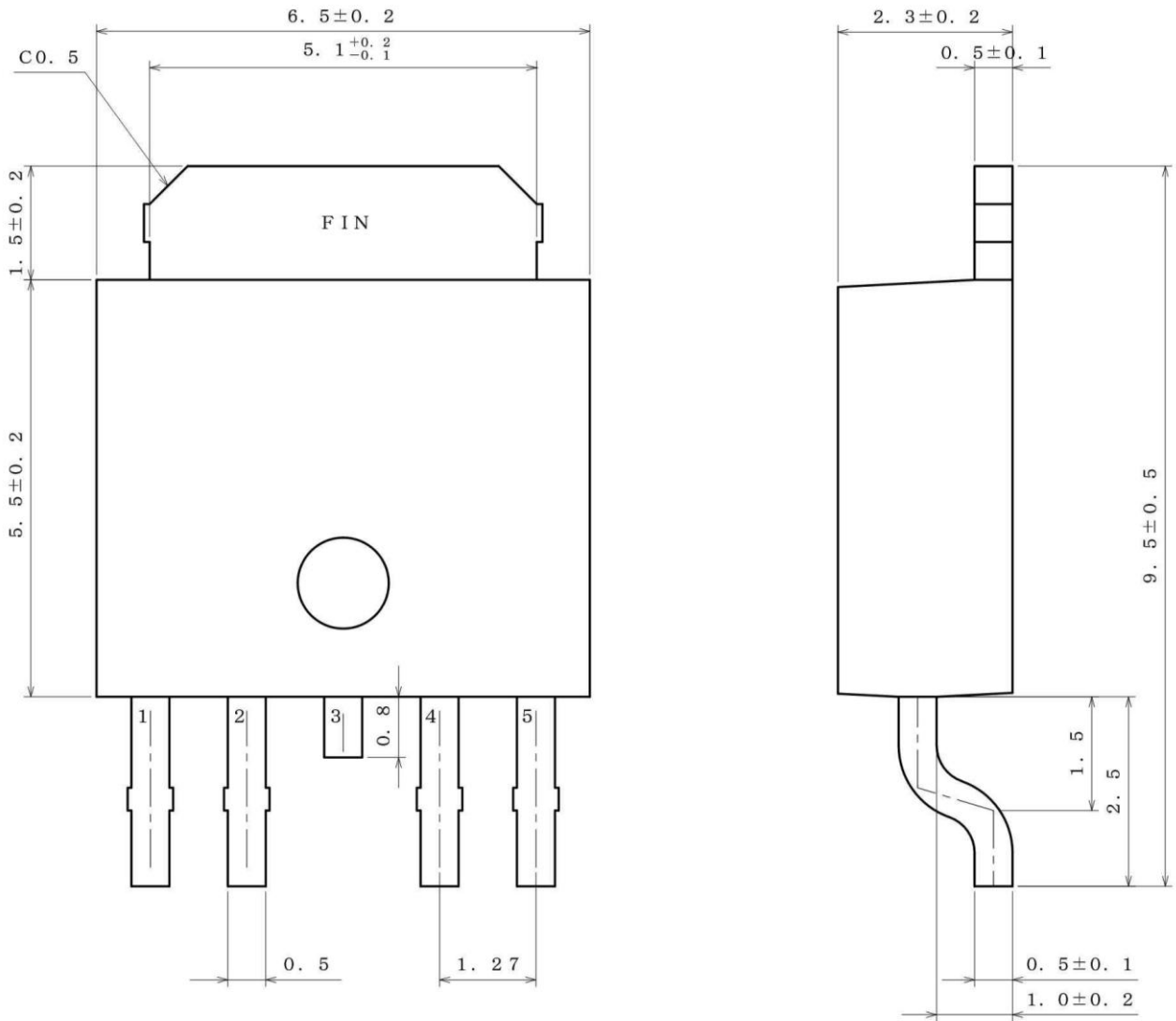

(UNIT : mm)
 PKG : TO252-5
 Drawing No. EX536-5001-1

<Tape and Reel information>

Tape	Embossed carrier tape
Quantity	2000pcs
Direction of feed	E2 (The direction is the 1pin of product is at the lower left when you hold reel on the left hand and you pull out the tape on the right hand)

*Order quantity needs to be multiple of the minimum quantity.

Physical Dimensions, Tape and Reel Information - continued

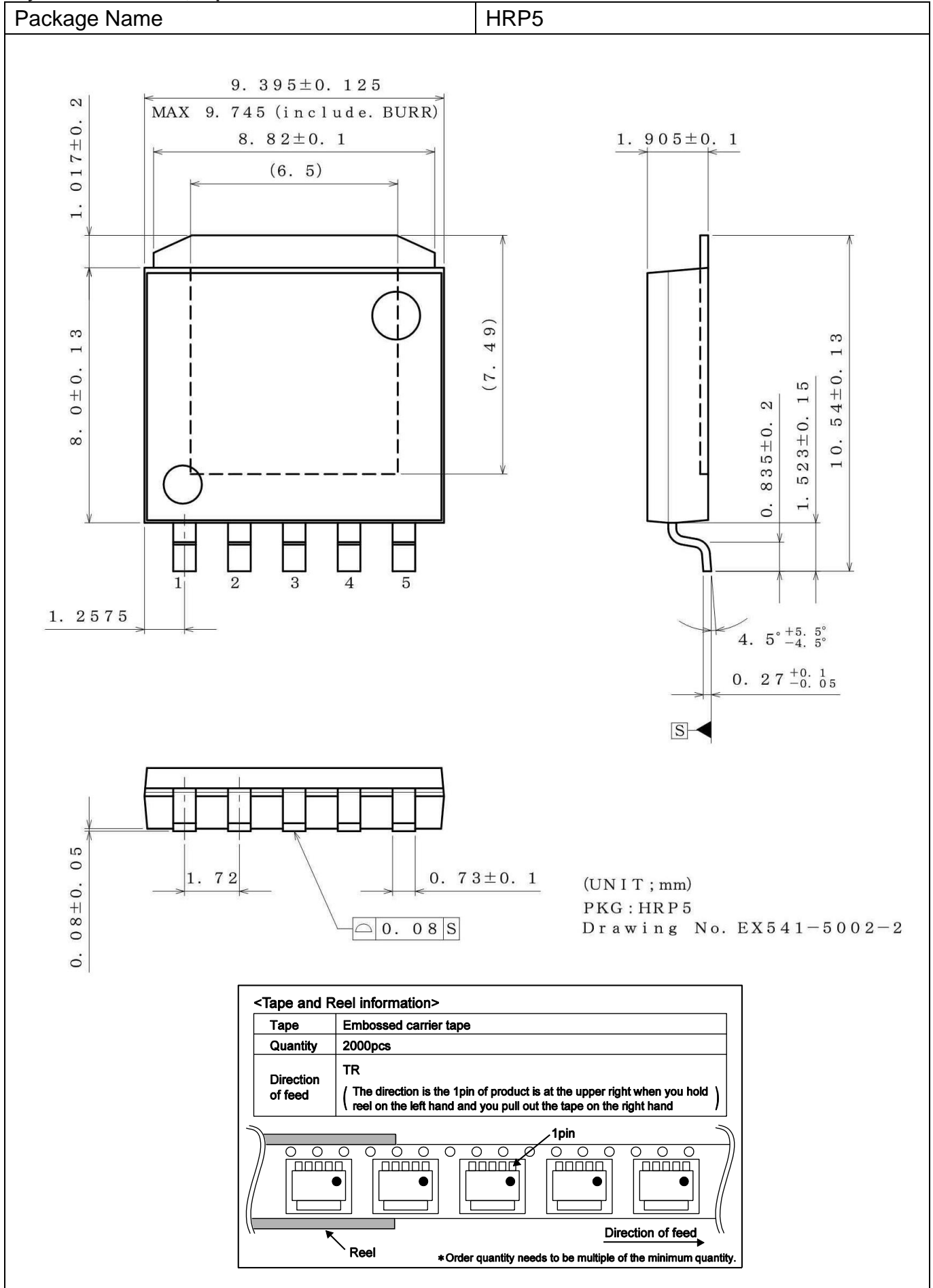

Revision History

Date	Revision	Changes
20.Oct.2014	001	New Release

Notice

Precaution on using ROHM Products

1. If you intend to use our Products in devices requiring extremely high reliability (such as medical equipment ^(Note 1), aircraft/spacecraft, nuclear power controllers, etc.) and whose malfunction or failure may cause loss of human life, bodily injury or serious damage to property ("Specific Applications"), please consult with the ROHM sales representative in advance. Unless otherwise agreed in writing by ROHM in advance, ROHM shall not be in any way responsible or liable for any damages, expenses or losses incurred by you or third parties arising from the use of any ROHM's Products for Specific Applications.

(Note1) Medical Equipment Classification of the Specific Applications

JAPAN	USA	EU	CHINA
CLASS III	CLASS III	CLASS II b	CLASS III
CLASS IV		CLASS III	

2. ROHM designs and manufactures its Products subject to strict quality control system. However, semiconductor products can fail or malfunction at a certain rate. Please be sure to implement, at your own responsibilities, adequate safety measures including but not limited to fail-safe design against the physical injury, damage to any property, which a failure or malfunction of our Products may cause. The following are examples of safety measures:
 - [a] Installation of protection circuits or other protective devices to improve system safety
 - [b] Installation of redundant circuits to reduce the impact of single or multiple circuit failure
3. Our Products are not designed under any special or extraordinary environments or conditions, as exemplified below. Accordingly, ROHM shall not be in any way responsible or liable for any damages, expenses or losses arising from the use of any ROHM's Products under any special or extraordinary environments or conditions. If you intend to use our Products under any special or extraordinary environments or conditions (as exemplified below), your independent verification and confirmation of product performance, reliability, etc. prior to use, must be necessary:
 - [a] Use of our Products in any types of liquid, including water, oils, chemicals, and organic solvents
 - [b] Use of our Products outdoors or in places where the Products are exposed to direct sunlight or dust
 - [c] Use of our Products in places where the Products are exposed to sea wind or corrosive gases, including Cl₂, H₂S, NH₃, SO₂, and NO₂
 - [d] Use of our Products in places where the Products are exposed to static electricity or electromagnetic waves
 - [e] Use of our Products in proximity to heat-producing components, plastic cords, or other flammable items
 - [f] Sealing or coating our Products with resin or other coating materials
 - [g] Use of our Products without cleaning residue of flux (even if you use no-clean type fluxes, cleaning residue of flux is recommended); or Washing our Products by using water or water-soluble cleaning agents for cleaning residue after soldering
 - [h] Use of the Products in places subject to dew condensation
4. The Products are not subject to radiation-proof design.
5. Please verify and confirm characteristics of the final or mounted products in using the Products.
6. In particular, if a transient load (a large amount of load applied in a short period of time, such as pulse. is applied, confirmation of performance characteristics after on-board mounting is strongly recommended. Avoid applying power exceeding normal rated power; exceeding the power rating under steady-state loading condition may negatively affect product performance and reliability.
7. De-rate Power Dissipation (Pd) depending on Ambient temperature (Ta). When used in sealed area, confirm the actual ambient temperature.
8. Confirm that operation temperature is within the specified range described in the product specification.
9. ROHM shall not be in any way responsible or liable for failure induced under deviant condition from what is defined in this document.

Precaution for Mounting / Circuit board design

1. When a highly active halogenous (chlorine, bromine, etc.) flux is used, the residue of flux may negatively affect product performance and reliability.
2. In principle, the reflow soldering method must be used on a surface-mount products, the flow soldering method must be used on a through hole mount products. If the flow soldering method is preferred on a surface-mount products, please consult with the ROHM representative in advance.

For details, please refer to ROHM Mounting specification

Precautions Regarding Application Examples and External Circuits

1. If change is made to the constant of an external circuit, please allow a sufficient margin considering variations of the characteristics of the Products and external components, including transient characteristics, as well as static characteristics.
2. You agree that application notes, reference designs, and associated data and information contained in this document are presented only as guidance for Products use. Therefore, in case you use such information, you are solely responsible for it and you must exercise your own independent verification and judgment in the use of such information contained in this document. ROHM shall not be in any way responsible or liable for any damages, expenses or losses incurred by you or third parties arising from the use of such information.

Precaution for Electrostatic

This Product is electrostatic sensitive product, which may be damaged due to electrostatic discharge. Please take proper caution in your manufacturing process and storage so that voltage exceeding the Products maximum rating will not be applied to Products. Please take special care under dry condition (e.g. Grounding of human body / equipment / solder iron, isolation from charged objects, setting of Ionizer, friction prevention and temperature / humidity control).

Precaution for Storage / Transportation

1. Product performance and soldered connections may deteriorate if the Products are stored in the places where:
 - [a] the Products are exposed to sea winds or corrosive gases, including Cl₂, H₂S, NH₃, SO₂, and NO₂
 - [b] the temperature or humidity exceeds those recommended by ROHM
 - [c] the Products are exposed to direct sunshine or condensation
 - [d] the Products are exposed to high Electrostatic
2. Even under ROHM recommended storage condition, solderability of products out of recommended storage time period may be degraded. It is strongly recommended to confirm solderability before using Products of which storage time is exceeding the recommended storage time period.
3. Store / transport cartons in the correct direction, which is indicated on a carton with a symbol. Otherwise bent leads may occur due to excessive stress applied when dropping of a carton.
4. Use Products within the specified time after opening a humidity barrier bag. Baking is required before using Products of which storage time is exceeding the recommended storage time period.

Precaution for Product Label

QR code printed on ROHM Products label is for ROHM's internal use only.

Precaution for Disposition

When disposing Products please dispose them properly using an authorized industry waste company.

Precaution for Foreign Exchange and Foreign Trade act

Since our Products might fall under controlled goods prescribed by the applicable foreign exchange and foreign trade act, please consult with ROHM representative in case of export.

Precaution Regarding Intellectual Property Rights

1. All information and data including but not limited to application example contained in this document is for reference only. ROHM does not warrant that foregoing information or data will not infringe any intellectual property rights or any other rights of any third party regarding such information or data. ROHM shall not be in any way responsible or liable for infringement of any intellectual property rights or other damages arising from use of such information or data.:
2. No license, expressly or implied, is granted hereby under any intellectual property rights or other rights of ROHM or any third parties with respect to the information contained in this document.

Other Precaution



1. This document may not be reprinted or reproduced, in whole or in part, without prior written consent of ROHM.
2. The Products may not be disassembled, converted, modified, reproduced or otherwise changed without prior written consent of ROHM.
3. In no event shall you use in any way whatsoever the Products and the related technical information contained in the Products or this document for any military purposes, including but not limited to, the development of mass-destruction weapons.
4. The proper names of companies or products described in this document are trademarks or registered trademarks of ROHM, its affiliated companies or third parties.

General Precaution

1. Before you use our Products, you are requested to carefully read this document and fully understand its contents. ROHM shall not be in any way responsible or liable for failure, malfunction or accident arising from the use of any ROHM's Products against warning, caution or note contained in this document.
2. All information contained in this document is current as of the issuing date and subject to change without any prior notice. Before purchasing or using ROHM's Products, please confirm the latest information with a ROHM sales representative.
3. The information contained in this document is provided on an "as is" basis and ROHM does not warrant that all information contained in this document is accurate and/or error-free. ROHM shall not be in any way responsible or liable for any damages, expenses or losses incurred by you or third parties resulting from inaccuracy or errors of or concerning such information.

Looking for pricing, stock, or lifecycle information?

Click below to explore more details on WIN SOURCE:

-  [View BD3925FP-CE2](#) on WIN SOURCE
-  [Rohm Semiconductor](#) Information

Optimize Your Supply Chain with WIN SOURCE Solutions

-  Global Sourcing Solution
-  Obsolete Management
-  Cost Control Management
-  Shortage Management
-  Alternative Solution
-  Excess Inventory Management