



**THE DATASHEET OF
BL02RN1R2M2B**



Ferrite Bead Inductor BL02/BL03 Series Reference Specification

1. Scope

This reference specification applies Ferrite Bead Inductor (Radial Type).

2. Part Numbering

(Ex.)	BL	02	RN	1	R2	N	1	A	
	Product ID	Series	Bead Core Material	Number of Bead Core	(*1)Lead Type	(*2)Lead Length, Space	(*3)Lead Diameter	(*4)Packaging	
(*1) R1 :	Radial Straight Type			(*2) J :	Lead Length 5.0mm	(*3) 1 :	ϕ 0.60mm	(*4) A :	Ammo Pack
R2 :	Radial Straight and Wave Formed Leads			M :	Lead Length 10.0mm	2 :	ϕ 0.65mm	B :	Bulk
R3 :	Radial Crimp Type			N :	Lead Length 16.5mm				
				P :	Lead Length 18.5mm				
				Q :	Lead Length 20.0mm				

3. Rating

Customer Part Number	MURATA Part Number	Inductance (1MHz)	Rated Current	DC Resistance	Remark		Unit Mass (Typical value)
					H1 size (*1) mm	Packing Style	
	BL02RN1R2M2B	0.45 μ H min.	7 A	0.02 Ω max.	–	Bulk	0.34g
	BL02RN1R2N1A		6 A		16.5 \pm 0.5	Ammo Pack	0.40g
	BL02RN1R2Q1A				20.0 \pm 0.5		0.42g
	BL02RN1R2P1A				18.5 \pm 0.5		0.41g
	BL02RN1R3J2B				7 A		–
	BL02RN1R3N1A	6 A	16.5 \pm 0.5		Ammo Pack	0.42g	
	BL02RN2R1M2B	1.10 μ H min.	7 A		–	Bulk	0.57g
	BL02RN2R1N1A		6 A		16.5 \pm 0.5	Ammo Pack	0.63g
	BL02RN2R1Q1A				20.0 \pm 0.5		0.65g
	BL02RN2R1P1A				18.5 \pm 0.5		0.64g
	BL02RN2R3J2B				7 A		–
	BL02RN2R3N1A	6 A	16.5 \pm 0.5		Ammo Pack	0.65g	
	BL03RN2R1M1B	0.45 μ H min.	6 A		–	Bulk	0.21g
	BL03RN2R1N1A				16.5 \pm 0.5	Ammo Pack	0.29g
	BL03RN2R1Q1A				20.0 \pm 0.5		0.30g
	BL03RN2R1P1A			18.5 \pm 0.5	0.29g		

• Operating Temperature : - 40 °C to + 85 °C
(*1) H1 : See item 10.1.

• Storage Temperature : - 40 °C to + 100 °C

4. Style and Dimension

Bulk : See item 9. / Taping : See item 10.1.

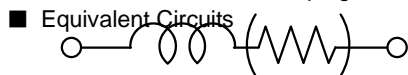

(Resistance element becomes dominant at high frequencies.)

5. Marking

No Marking

6. Testing Conditions

<Unless otherwise specified>

Temperature : Ordinary Temp. 15°C to 35°C

Humidity : Ordinary Humidity 25 %(RH) to 85 %(RH)

<In case of doubt>

Temperature : 20°C \pm 2°C

Humidity : 60 %(RH) to 70 %(RH)

Atmospheric pressure : 86kPa to 106kPa

7. Electrical Performance

No.	Item	Specification	Test Method
7.1	Bend Bonding Strength	Appearance : No damage.	Applying Force : 9.8N Applying direction : The lead wire in the direction of the axes. Keeping Time : 1s to 5s
7.2	Drop	Appearance : No damage.	Products shall be dropped on the plate of oak. Height : 75 cm The Number of Times : 3 times
7.3	Solderability	Along the circumference of terminal shall be covered with new solder at least 75%	Flux : Ethanol solution of rosin, 25(wt)% Pre-heat : 150 ± 10 °C, 60 ~ 90 s Solder : Sn-3.0Ag-0.5Cu Solder Temperature : 245 ± 5 °C Immersion Time : 2 ± 0.5 s
7.4	Resistance to Soldering Heat	Appearance : No damage.	Flux : Ethanol solution of rosin, 25(wt)% Pre-heat : 150 ± 10 °C, 60 ~ 90 s Solder : Sn-3.0Ag-0.5Cu Solder Temperature : 260 ± 5 °C Immersion Time : 10 ± 1 s Immersion Depth : 1.6 ± 0.8 mm from the end of Ferrite Bead Immersion and emersion rates : 25 ± 5 mm / s
7.5	Resistance to Soldering iron		Tip Temperature : 350 °C ± 10 °C Soldering Time : 3 s ± 0.5 s Putting place of soldering iron : lead wire (1.6±0.8mm from the bottom of the Ferrite Bead) Do not touch the Ferrite Bead directly with the tip of the soldering iron.
7.6	Vibration		Oscillation Frequency : 10 Hz to 2000 Hz for 20 min. Total Amplitude or acceleration : 1.5 mm or 196 m/s ² Testing Time : A period of 2 hours in each of 3 mutually perpendicular directions. (Total 6 hours)
7.7	Humidity	Appearance : No damaged. Inductance change : within ± 15%	Temperature : 85 °C ± 2 °C Humidity : 80 %(RH) to 85 %(RH) Time : 500 h (+ 24h , - 0h) Then measured after exposure in the room condition for 1 to 2 hours.
7.8	Thermal Shock		1 cycle : 1 step : - 40°C (+0,-3) °C / 30 min. (+3,-0) min. 2 step : Ordinary Temp. / within 1 min. 3 step : + 85°C (+3,-0) °C / 30min. (+3,-0) min. 4 step : Ordinary Temp. / within 1min. Total of 10 cycles Then measured after exposure in the room condition for 4 to 48 hours.
7.9	Heat Resistance		Temperature : 85 °C ± 3 °C Time : 1000 h (+ 48h , - 0h) Then measured after exposure in the room condition for 1 to 2 hours.

8. Frequency-Impedance Characteristics (Typical)

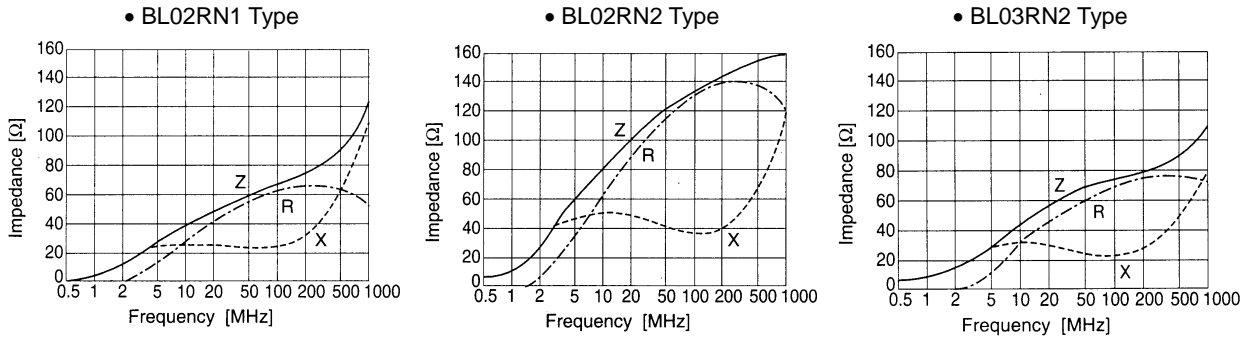

9. Style and Dimension (Bulk)

(1) BL02RN1R2M2B

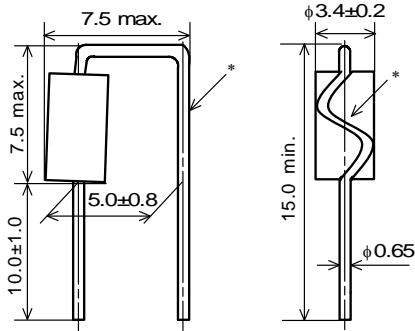

(2) BL02RN1R3J2B

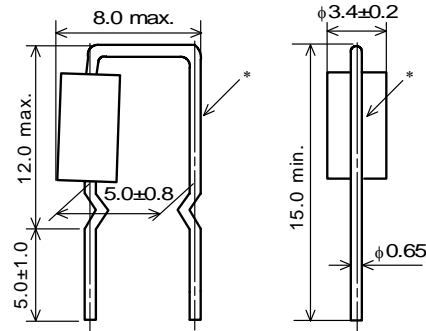

* There is a excess bond stick on the wire.

(3) BL02RN2R1M2B

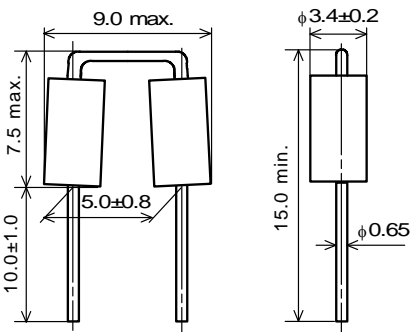

(4) BL02RN2R3J2B

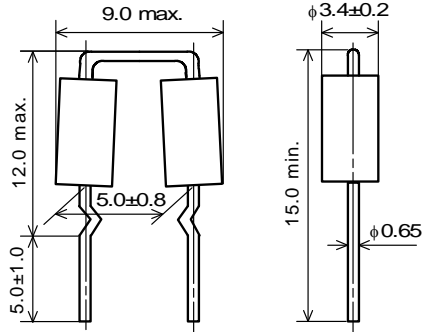

(5) BL03RN2R1M1B

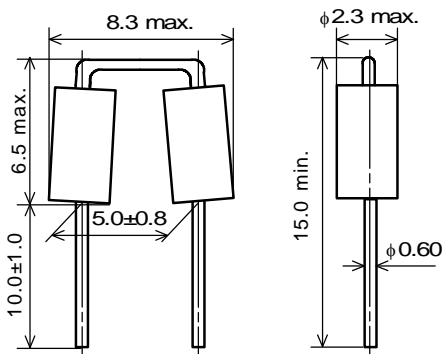

(in mm)

10. Specification of Packaging

10.1. Style and Dimension

(1) BL02RN1R2□1A Series

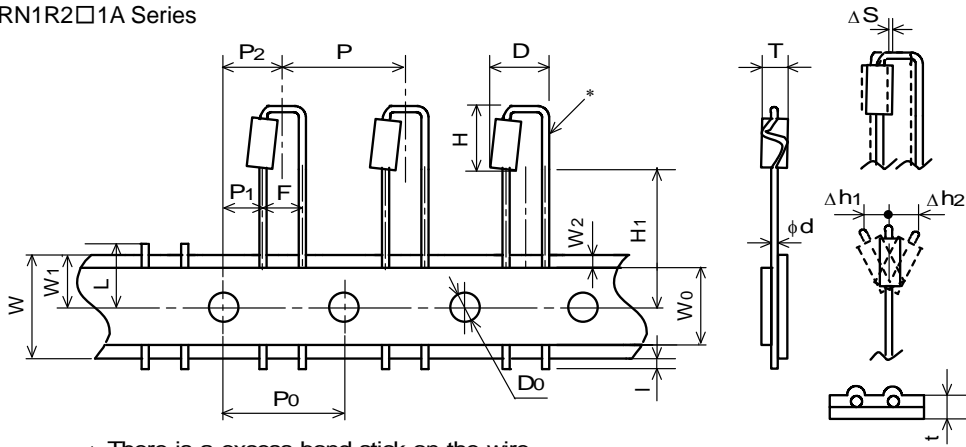

Symbol	Description	Dimension (mm)		Remarks
P	Pitch of component	12.7		Product inclination ΔS determines tolerance
P ₀	Pitch of sprocket hole	12.7 ± 0.2		
F	Lead spacing	5.0 (+0.8, -0.2)		
P ₁	Hole center to lead	3.85 ± 0.7		
P ₂	Hole center to component center	6.35 ± 1.3		Tape deviation in feeding direction
D	Body width	7.5 max.		
H	Height of bead	7.5 max.		
ΔS	Deviation along tape, left or right	± 1.0		
W	Carrier tape width	18.0 ± 0.5		
W ₁	Position of sprocket hole	9.0 (+0, -0.5)		Tape with deviation
H ₁	Lead length between sprocket hole and forming position	Lead Length Number : N	16.5 ± 0.5	
		Lead Length Number : Q	20.0 ± 0.5	
		Lead Length Number : P	18.5 ± 0.5	
I	Protruding length	+ 0.5 ~ - 1.0		
D ₀	Diameter of sprocket hole	φ 4.0 ± 0.1		
φd	Lead Diameter	φ 0.60		
t	Total tape thickness	0.7 ± 0.2		Including bonding tape thickness
Δh_1	Deviation across tape	1.0 max.		
Δh_2	Deviation across tape rear			
L	Cutting position of failure	11.0 (+0, -1.0)		
W ₀	Hold down tape width	12.0 ± 0.5		
W ₂	Hold down tape position	1.5 ± 1.5		
T	Body thickness	3.4 ± 0.2		

(2) BL02RN1R3N1A

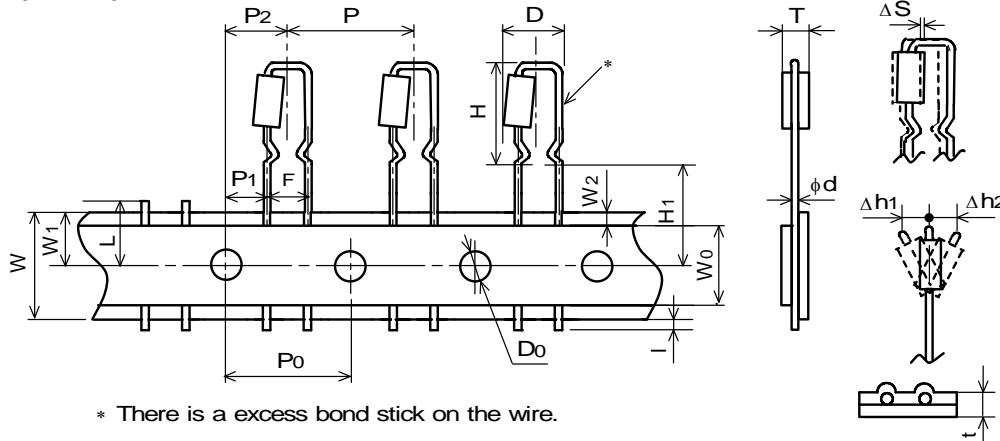

Symbol	Description	Dimension (mm)	Remarks
P	Pitch of component	12.7	Product inclination ΔS determines tolerance
P ₀	Pitch of sprocket hole	12.7 ± 0.2	
F	Lead spacing	5.0 (+0.8 , -0.2)	
P ₁	Hole center to lead	3.85 ± 0.7	
P ₂	Hole center to component center	6.35 ± 1.3	Tape deviation in feeding direction
D	Body width	8.0 max.	
H	Height of bead	12.0 max.	
ΔS	Deviation along tape, left or right	± 1.0	
W	Carrier tape width	18.0 ± 0.5	
W ₁	Position of sprocket hole	9.0 (+0 , -0.5)	Tape with deviation
H ₁	Lead length between sprocket hole and forming position	16.5 ± 0.5	
l	Protruding length	+ 0.5 ~ - 1.0	
D ₀	Diameter of sprocket hole	φ 4.0 ± 0.1	
φd	Lead Diameter	φ 0.60	
t	Total tape thickness	0.7 ± 0.2	Including bonding tape thickness
Δh_1	Deviation across tape	1.0 max.	
Δh_2	Deviation across tape rear		
L	Cutting position of failure	11.0 (+0 , -1.0)	
W ₀	Hold down tape width	12.0 ± 0.5	
W ₂	Hold down tape position	1.5 ± 1.5	
T	Body thickness	3.4 ± 0.2	

(3) BL02RN2R1□1A Series

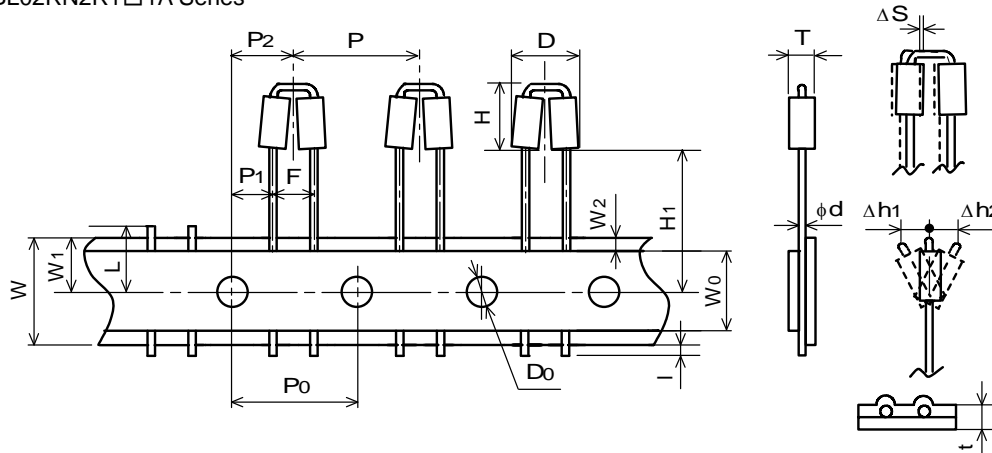

Symbol	Description	Dimension (mm)		Remarks
P	Pitch of component	12.7		Product inclination ΔS determines tolerance
P ₀	Pitch of sprocket hole	12.7 ± 0.2		
F	Lead spacing	5.0 (+0.8, -0.2)		
P ₁	Hole center to lead	3.85 ± 0.7		
P ₂	Hole center to component center	6.35 ± 1.3		Tape deviation in feeding direction
D	Body width	9.0 max.		
H	Height of bead	7.5 max.		
ΔS	Deviation along tape, left or right	± 1.0		
W	Carrier tape width	18.0 ± 0.5		
W ₁	Position of sprocket hole	9.0 (+0, -0.5)		Tape with deviation
H ₁	Lead length between sprocket hole and forming position	Lead Length Number : N	16.5 ± 0.5	
		Lead Length Number : Q	20.0 ± 0.5	
		Lead Length Number : P	18.5 ± 0.5	
l	Protruding length	+ 0.5 ~ - 1.0		
D ₀	Diameter of sprocket hole	φ 4.0 ± 0.1		
φd	Lead Diameter	φ 0.60		
t	Total tape thickness	0.7 ± 0.2		Including bonding tape thickness
Δh_1	Deviation across tape	1.0 max.		
Δh_2	Deviation across tape rear			
L	Cutting position of failure	11.0 (+0, -1.0)		
W ₀	Hold down tape width	12.0 ± 0.5		
W ₂	Hold down tape position	1.5 ± 1.5		
T	Body thickness	3.4 ± 0.2		

(4) BL02RN2R3N1A

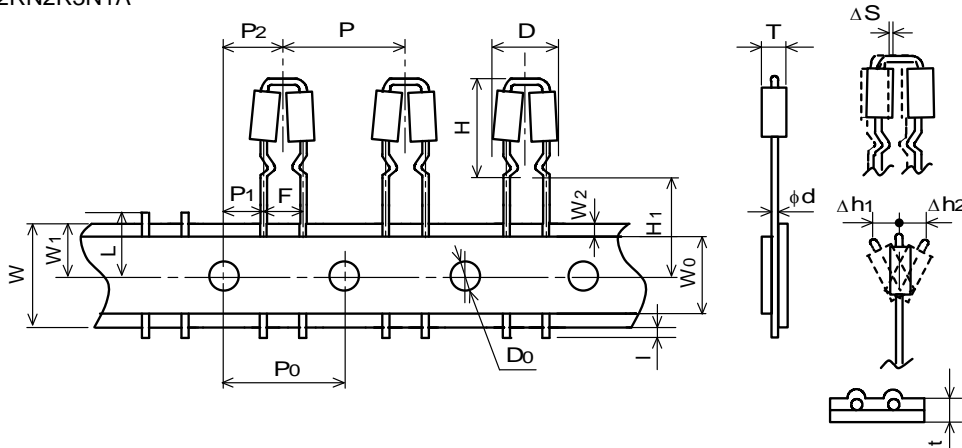

Symbol	Description	Dimension (mm)	Remarks
P	Pitch of component	12.7	Product inclination ΔS determines tolerance
P_0	Pitch of sprocket hole	12.7 ± 0.2	
F	Lead spacing	$5.0 (+0.8, -0.2)$	
P_1	Hole center to lead	3.85 ± 0.7	
P_2	Hole center to component center	6.35 ± 1.3	Tape deviation in feeding direction
D	Body width	9.0 max.	
H	Height of bead	12.0 max.	
ΔS	Deviation along tape, left or right	± 1.0	
W	Carrier tape width	18.0 ± 0.5	
W_1	Position of sprocket hole	$9.0 (+0, -0.5)$	Tape with deviation
H_1	Lead length between sprocket hole and forming position	16.5 ± 0.5	
l	Protruding length	$+0.5 \sim -1.0$	
D_0	Diameter of sprocket hole	$\phi 4.0 \pm 0.1$	
ϕd	Lead Diameter	$\phi 0.60$	
t	Total tape thickness	0.7 ± 0.2	Including bonding tape thickness
Δh_1	Deviation across tape	1.0 max.	
Δh_2	Deviation across tape rear		
L	Cutting position of failure	$11.0 (+0, -1.0)$	
W_0	Hold down tape width	12.0 ± 0.5	
W_2	Hold down tape position	1.5 ± 1.5	
T	Body thickness	3.4 ± 0.2	

(5) BL03RN2R1□1A Series

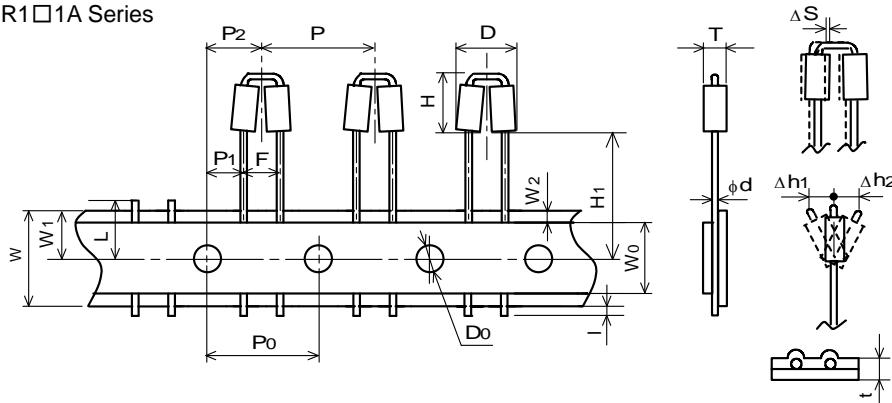

Symbol	Description	Dimension (mm)		Remarks
P	Pitch of component	12.7		Product inclination ΔS determines tolerance
P ₀	Pitch of sprocket hole	12.7 ± 0.2		
F	Lead spacing	5.0 (+0.8, -0.2)		
P ₁	Hole center to lead	3.85 ± 0.7		
P ₂	Hole center to component center	6.35 ± 1.3		Tape deviation in feeding direction
D	Body width	8.3 max.		
H	Height of bead	6.5 max.		
ΔS	Deviation along tape, left or right	± 1.0		
W	Carrier tape width	18.0 ± 0.5		
W ₁	Position of sprocket hole	9.0 (+0, -0.5)		Tape with deviation
H ₁	Lead length between sprocket hole and forming position	Lead Length Number : N	16.5 ± 0.5	
		Lead Length Number : Q	20.0 ± 0.5	
		Lead Length Number : P	18.5 ± 0.5	
l	Protruding length	+ 0.5 ~ - 1.0		
D ₀	Diameter of sprocket hole	φ 4.0 ± 0.1		
φd	Lead Diameter	φ 0.60		
t	Total tape thickness	0.7 ± 0.2		Including bonding tape thickness
Δh_1	Deviation across tape	1.0 max.		
Δh_2	Deviation across tape rear			
L	Cutting position of failure	11.0 (+0, -1.0)		
W ₀	Hold down tape width	12.0 ± 0.5		
W ₂	Hold down tape position	1.5 ± 1.5		
T	Body thickness	2.3 max.		

10.2. Supplement condition of taping

- (1) A maximum of 0.3% of the components quantity per reel or Ammo pack may be missing without consecutive missing components.
- (2) The adhesive power of the tape shall have over 2.94N at the following condition.

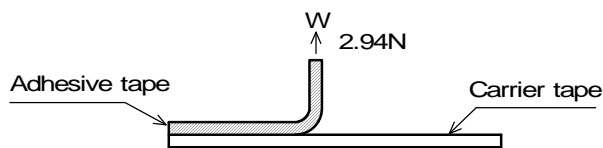

(3) Splicing method of tape

1. Carrier tape

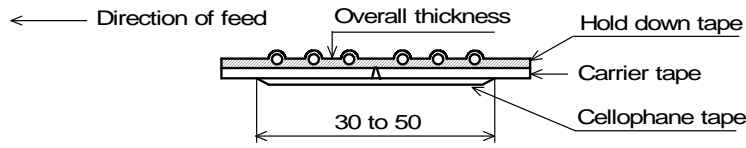

Carrier tape shall be spliced by cellophane tape.
Overall thickness shall be less than 1.05 mm max. (in mm)

2. Hold down tape

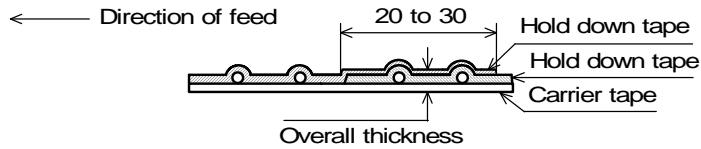

- Hold down tape shall be spliced with overlapping.
- Overall thickness shall be less than 1.05 mm. (in mm)

3. Both carrier tape and hold down tape

Both tapes shall be cut zigzag and spliced with splicing tape.

10.3. Leader of tape

Not less than 3 consecutive of component shall be missing on both edge of tape.

11. Packing**11.1. Packing quantity**

The standard packing quantity is as follows.

Murata Part Number	Quantity (pcs.)	Remark
BL02RN1 Type	500	Bulk
BL02RN2 Type		
BL03RN2 Type		
BL02RN1 Type	1500	Ammo Pack
BL02RN2 Type		
BL03RN2 Type		

11.2. Packing Form

(1) Bulk

Product are packed into a plastic bag.

13. Notice

13.1. Soldering

- (1) Flux, Solder
 - Rosin-based flux should be used.
 - Do not use strong acidic flux with halide content exceeding 0.2(wt)% (chlorine conversion value.)
 - Use Sn-3.0Ag-0.5Cu solder.

(2) Standard flow soldering profile.

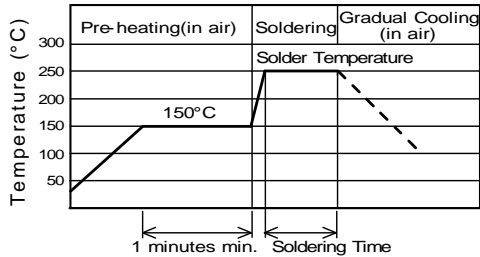

- (3) Resistance to soldering iron goes in the following condition that tip temperature is 350 °C max. and soldering time is 5 s max.
- (4) Products and the leads should not be subjected to any mechanical stress during soldering process. (and also while subjected to the equivalent high temperature.)

13.2. Cleaning conditions

Products shall be cleaned on the following conditions.

- (1) Cleaning temperature shall be limited to 60°C max.(40°C max for IPA.)
- (2) Ultrasonic cleaning shall comply with the following conditions with avoiding the resonance phenomenon at the mounted products and P.C.B.

Power : 20 W / l max. Frequency : 28kHz to 40kHz Time : 5 min max.

- (3) Cleaner
 1. Alcohol type cleaner
 - Isopropyl alcohol (IPA)
 2. Aqueous agent
 - PINE ALPHA ST-100S

- (4) There shall be no residual flux and residual cleaner after cleaning.
 - In case of using aqueous agent, products shall be dried completely after rinse with de-ionized water in order to remove the cleaner.
- (5) Other cleaning
 - Please contact us.

13.3. Operating Environment

- (1) Do not use products in corrosive gases such as chlorine gas, acid or sulfide gas.
- (2) Do not use products in the environment where water, oil or organic solvents may adhere to product.
- (3) Do not adhere any resin to products, coat nor mold products with any resin (including adhesive) to prevent mechanical and chemical stress on products.

13.4. Storage and Handling Requirements

- (1) Storage period
 - Use the products within 12 months after delivered.
 - Solderability should be checked if this period is exceeded.

(2) Storage conditions

- Products should be stored in the warehouse on the following conditions.

Temperature : -10 °C to 40 °C

Humidity : 15 % to 85 % relative humidity No rapid change on temperature and humidity

The electrode of the products is coated with solder. Don't keep products in corrosive gases such as sulfur, chlorine gas or acid, or it may cause oxidization of electrode, resulting in poor solderability.

- Products should not be stored on bulk packaging condition to prevent the chipping of the core and the breaking of winding wire caused by the collision between the products.
- Products should be stored on the palette for the prevention of the influence from humidity, dust and so on.
- Products should be stored in the warehouse without heat shock, vibration, direct sunlight and so on.

(3) Handling Condition

Care should be taken when transporting or handling product to avoid excessive vibration or mechanical shock.

14.  Note

- (1) Please make sure that your product has been evaluated in view of your specifications with our product being mounted to your product.
- (2) You are requested not to use our product deviating from the reference specifications.
- (3) The contents of this reference specification are subject to change without advance notice. Please approve our product specifications or transact the approval sheet for product specifications before ordering.

Looking for pricing, stock, or lifecycle information?

Click below to explore more details on WIN SOURCE:

- ⊖ [View BL02RN1R2M2B on WIN SOURCE](#)
- ⊖ [Murata Electronics North America Information](#)

Optimize Your Supply Chain with WIN SOURCE Solutions

- ✓ Global Sourcing Solution
- ✓ Obsolete Management
- ✓ Cost Control Management
- ✓ Shortage Management
- ✓ Alternative Solution
- ✓ Excess Inventory Management