



**THE DATASHEET OF  
BM92A21MWV-ZE2**



# USB Type-C Power Delivery Controller

## BM92A21MWV-Z

### General Description

BM92A21 is a USB Type-C Power Delivery (PD) controller that supports USB Power Delivery using base-band communication. It is compatible with USB Type-C Specification and USB Power Delivery specification.

BM92A21 includes support for the PD policy engine and be able to operate independently. In addition, this IC has secondary side error amplifier that support variable output voltage and it is suitable for PD AC adapter systems.

### Key Specifications

- VEX Voltage Range: 4.75V to 20V
- VBUS Voltage Range: 4.75V to 20V
- Power Consumption at Sleep Power: 0.9mW(Typ)
- Operating Temperature Range: -30°C to +105°C

### Package

UQFN40V5050A

W (Typ) x D (Typ) x H (Max)  
5.00mm x 5.00mm x 1.00mm

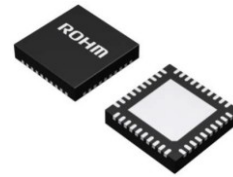

### Features

- USB Type-C Specification compatible
- USB PD Specification compatible (BMC-PHY)
- Power path control using N-channel MOSFET drivers with back flow prevention
- Type-C cable orientation detection
- Supports DFP-SOURCE mode
- Integrated Secondary side of AC adapter system
- PDO1:5V/3A, PDO2:9V/3A, PDO3:12V/3A, PDO4:15V/3A, PDO5:20V/5A
- EC-less Operation (Auto mode)

### Applications

- Consumer Applications  
AC Adaptors, Chargers

### Typical Application Circuit

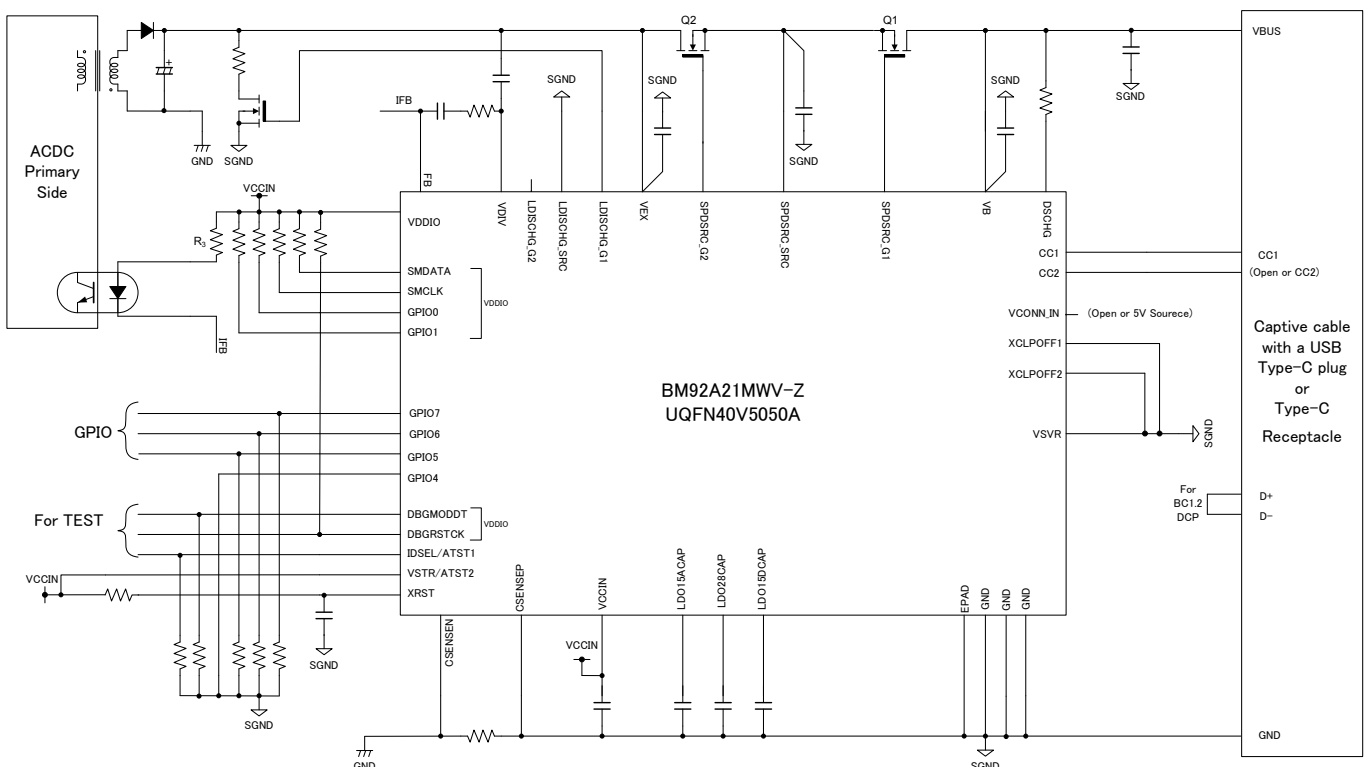

Figure A. Typical Application Circuit

○Product structure : Silicon monolithic integrated circuit ○This product has no designed protection against radioactive rays

# Contents

Contents .....	2
<b>Notation</b> .....	3
<b>Reference</b> .....	3
1. Pin Configuration .....	4
2. Pin Description .....	5
3. Block Diagram .....	7
4. Electrical Characteristics .....	8
4.1. Absolute Maximum Ratings .....	8
4.2. Thermal Resistance <sup>(Note 4)</sup> .....	8
4.3. Recommended Operating Conditions .....	9
4.4. Internal Memory Cell Characteristics .....	9
4.5. Circuit Power Characteristics .....	9
4.6. Digital Pin DC Characteristics .....	10
4.7. Power Supply Management .....	11
4.7.1. Outline .....	11
4.7.2. Electrical Characteristics .....	12
4.8. CC_PHY .....	13
4.8.1. Outline .....	13
4.8.2. Electrical Characteristics .....	14
4.9. Voltage Detection .....	15
4.9.1. Outline .....	15
4.9.2. Electrical Characteristics .....	15
4.10. VBUS Discharge .....	16
4.10.1. Outline .....	16
4.10.2. Electrical Characteristics .....	16
4.11. Power FET Gate Driver (Power Path and Discharge) .....	17
4.11.1. Outline .....	17
4.11.2. Electrical Characteristics .....	17
4.12. ACDC Bridge .....	18
4.12.1. Outline .....	18
4.12.2. Electrical Characteristics .....	18
4.13. Power On Sequence .....	20
4.13.1. Reset Timing .....	20
4.14. Power Off Sequence .....	20
4.15. I/O Equivalence Circuit .....	21
5. Application Example .....	25
5.1. Selection of Components Externally connected .....	25
6. Firmware Revision .....	26
7. Operational Notes .....	27
8. Ordering Information .....	29
9. Marking Diagrams .....	29
10. Physical Dimension Tape and Reel Information .....	30
11. Revision History .....	31

## Notation

Category	Notation	Description
Unit	V	Volt (Unit of voltage)
	A	Ampere (Unit of current)
	$\Omega$ , Ohm	Ohm (Unit of resistance)
	F	Farad (Unit of capacitance)
	deg., degree	degree Celsius (Unit of Temperature)
	Hz	Hertz (Unit of frequency)
	s (lower case)	second (Unit of time)
	min	minute (Unit of time)
	b, bit	bit (Unit of digital data)
	B, byte	1 byte = 8 bits
Unit prefix	M, mega-, mebi-	$2^{20} = 1,048,576$ (used with "bit" or "byte")
	M, mega-, million-	$10^6 = 1,000,000$ (used with " $\Omega$ " or "Hz")
	K, kilo-, kibi-	$2^{10} = 1,024$ (used with "bit" or "byte")
	k, kilo-	$10^3 = 1,000$ (used with " $\Omega$ " or "Hz")
	m, milli-	$10^{-3}$
	$\mu$ , micro-	$10^{-6}$
	n, nano-	$10^{-9}$
	p, pico-	$10^{-12}$
Numeric value	xxh, xxH	Hexadecimal number. "x": any alphanumeric of 0 to 9 or A to F.
	xxb	Binary number; "b" may be omitted. "x": a number, 0 or 1 "_" is used as a nibble (4-bit) delimiter. (eg. "0011_0101b" = "35h")
Address	#xxh	Address in a hexadecimal number. "x": any alphanumeric of 0 to 9 or A to F.
Data	bit[n]	n-th single bit in the multi-bit data.
	bit[n:m]	Bit range from bit[n] to bit[m].
Signal level	"H", High	High level (over $V_{IH}$ or $V_{OH}$ ) of logic signal.
	"L", Low	Low level (under $V_{IL}$ or $V_{OL}$ ) of logic signal.
	"Z", "Hi-Z"	High impedance state of 3-state signal.

## Reference

Name	Reference Document	Release Date	Publisher
USB Type-C	"USB Type-C Specification Release 1.1"	3.Apr.2015	USB.org
USB PD	"Power Delivery Specification Revision2.0 Version1.1"	7.May.2015	USB.org
SMBus	"System Management Bus (SMBus) Specification Version 2.0"	3.Aug.2000	System Management Implementers Forum



## 2. Pin Description

Table 2-1 Pin Description

PKG PIN#	Pin Name	BLOCK	I/O	Type	Digital I/O Level	Description
1	GND	GND	I	GND		Ground
2	VSTR/ATST2	TEST/Debug	IO	Analog		Analog TEST/ Debug Pin2
3	IDSEL/ATST1	TEST/Debug	I	Analog	VCCIN	SMBus ID (device address) selection "H":1Ah, "L":18h /Debug Pin1
4	XRST	Interface	I	Digital	VCCIN	Digital block Reset
5	VCCIN	USB-PD	O	Analog		Internal Power supply (For internal use, need to connect capacitor to GND)
6	VSVR	POWER	I	Power		Connect to Ground
7	DSCHG	Interface	IO	Analog		Discharge NMOS Drain
8	GND	GND	I	GND		Ground
9	VB	POWER	I	Power		Power Source from VBUS
10	GPIO4	Interface	I	Digital		Mode fixation (Fix: L)
11	GPIO5	Interface	O <sup>(Note 1)</sup>	Digital		NC pin
12	GPIO6	Interface	O <sup>(Note 1)</sup>	Digital		NC pin
13	GPIO7	Interface	O <sup>(Note 1)</sup>	Digital		NC pin
14	DBGSTCK	TEST	IO	Digital	VDDIO	Test for logic
15	DBGMODDT	TEST	IO	Digital	VDDIO	Test for logic
16	GPIO0	Interface	O <sup>(Note 1)</sup>	Digital	VDDIO	NC pin
17	GPIO1	Interface	O <sup>(Note 1)</sup>	Digital	VDDIO	Alert signal
18	VDDIO	POWER	I	Power		Interface Voltage
19	SMDATA	Interface	IO	Digital	VDDIO	SMBus Data
20	SMCLK	Interface	I	Digital	VDDIO	SMBus Clock
21	LDISCHG_G1	FET Gate Control	O	Analog		VEX Discharge
22	LDISCHG_SRC	FET Gate Control	I	Analog		VEX Discharge
23	LDISCHG_G2	FET Gate Control	O	Analog		Not used
24	SPDSRC_G1	FET Gate Control	O	Analog		Power Path FET Gate Control
25	SPDSRC_SRC	FET Gate Control	I	Analog		Power Path FET BG/SRC Voltage
26	SPDSRC_G2	FET Gate Control	O	Analog		Power Path FET Gate Control

(Note 1) N-ch Open Drain

PKG PIN#	Pin Name	BLOCK	I/O	Type	Digital I/O Level	Description
27	GND	GND	I	GND		Ground
28	VEX	POWER	I	Power		Extension Power Input
29	VDIV	ACDC Bridge	O	Analog	VCCIN	For phase compensation
30	FB	ACDC Bridge	O	Analog	VCCIN	Error AMP output
31	CSENSEN	ACDC Bridge	I	Analog	VCCIN	Current Sense Voltage Input Negative
32	CSENSEP	ACDC Bridge	I	Analog	VCCIN	Current Sense Voltage Input Positive
33	XCLPOFF1	CCPHY	I	Analog	VCCIN	Disable Clamper of CC1(Fix: L)
34	XCLPOFF2	CCPHY	I	Analog	VCCIN	Disable Clamper of CC2(Fix: L)
35	CC1	CCPHY	IO	Analog		Configuration channel 1 for Type-C
36	VCONN_IN	CCPHY	I	Analog		Input power for VCONN
37	CC2	CCPHY	IO	Analog		Configuration channel 2 for Type-C
38	LDO15DCAP	POWER	O	Analog		Internal LDO 1.5V for Digital Need Capacitor
39	LDO28CAP	POWER	O	Analog		Internal LDO 2.8V for Analog Need Capacitor
40	LDO15ACAP	POWER	O	Analog		Internal LDO 1.5V for Analog Need Capacitor

3. Block Diagram

BM92A21 is USB Type-C PD controller for AC adapter applications that supports Type-C DFP port control and USB Power Delivery using base-band communication. It is compatible with USB Type-C Specification and USB Power Delivery Specification. And it has ACDC Bridge which is constructed in Error Amplifier (for Fly back AC adapter system) and Current Sense (for variable OCP function).

BM92A21 includes the following functional blocks: Type-C Physical Layer (base-band PHY), BMC encoder / decoder, USB-PD Protocol engine, a N-ch MOSFET switch driver, OVP and Discharge FET. BM92A21 includes an EEPROM.

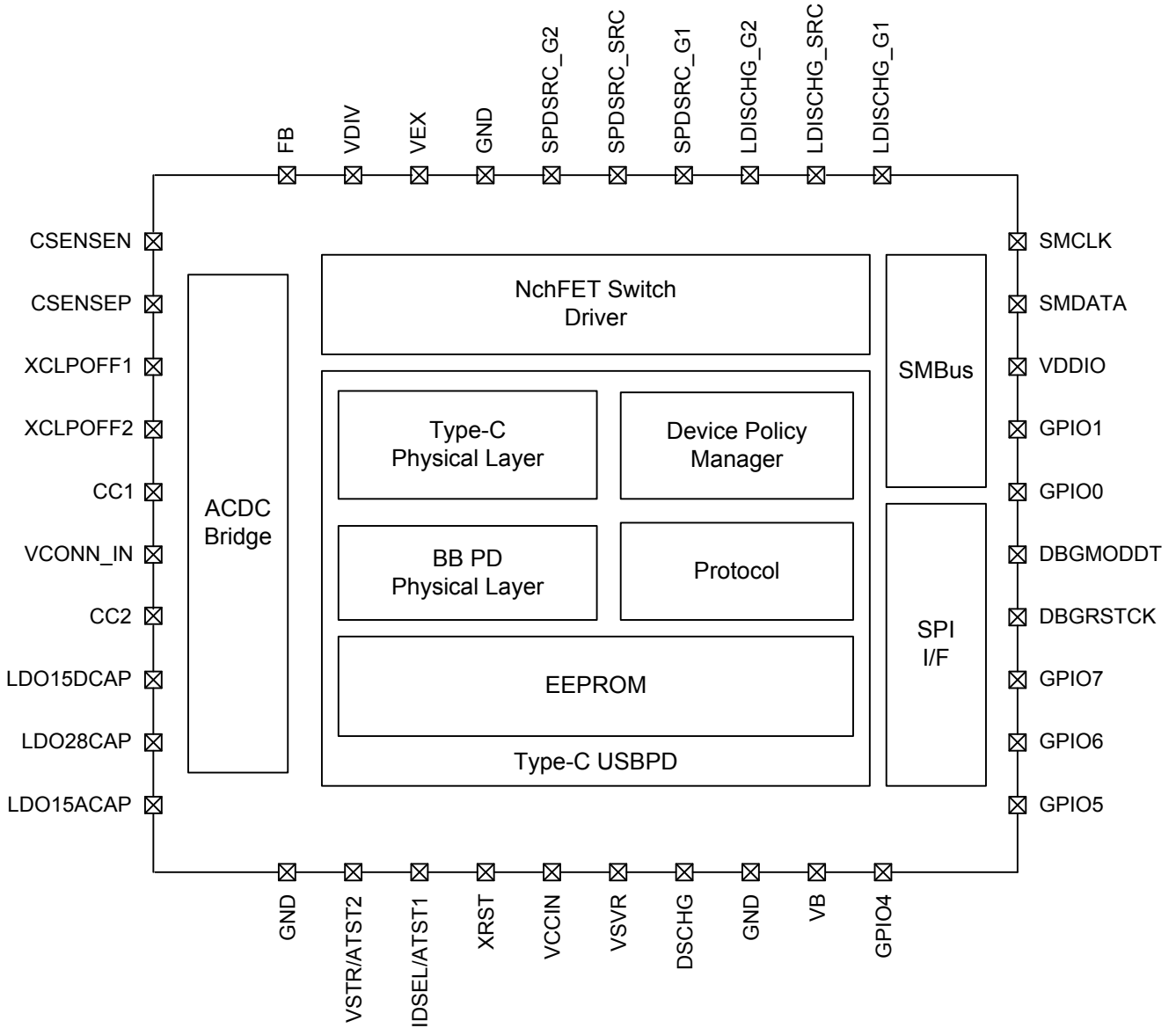

Figure 3-1 Block Diagram

4. Electrical Characteristics

4.1. Absolute Maximum Ratings

Table 4-1 Absolute Maximum Ratings

(Ta=25°C)

Parameter	Symbol	Rating	Unit	Conditions
Maximum Supply Voltage1 (VB, VEX, DSCHG, LDISCHG_G1, LDISCHG_G2, LDISCHG_SRC, SPDSRC_G1, SPDSRC_SRC, SPDSRC_G2 )	VIN1	-0.3 to +28	V	(Note 2) (Note 3)
Maximum Supply Voltage2 (VDDIO, VSVR, DBGRSTCK, DBGMODDT, GPIO0, GPIO1, SMDATA, SMCLK, XRST, VCONN_IN, VSTR/ATST2, IDSEL/ATST1, VCCIN, GPIO4, GPIO5, GPIO6, GPIO7, VDIV, FB, CSENSEN, CSENSEP, XCLPOFF1, XCLPOFF2, CC1, CC2, LDO28CAP)	VIN2	-0.3 to +6.5	V	
Maximum Supply Voltage3 (LDO15DCAP, LDO15ACAP)	VIN3	-0.3 to +2.1	V	
Maximum different Voltage (LDISCHG_G1 - LDISCHG_SRC, LDISCHG_G2 - LDISCHG_SRC, SPDSRC_G1 - SPDSRC_SRC, SPDSRC_G2 - SPDSRC_SRC)	Vdiff	-0.3 to +6.5	V	(Note 3)
Storage Temperature Range	Tstg	-55 to +125	°C	

(Note 2)When the DSCHG pin is applied voltage should by way of resistance more than 1kΩ.

(Note 3)The different voltage between S\*DRV\_G\* and S\*DRV\_SRC is defined "Symbol Vdiff". S\*\_DRV\_G\*=S\*\_DRV\_SRC+6.0V (typ)

Caution: Operating the IC over the absolute maximum ratings may damage the IC. The damage can either be a short circuit between pins or an open circuit between pins and the internal circuitry. Therefore, it is important to consider circuit protection measures, such as adding a fuse, in case the IC is operated over the absolute maximum ratings.

4.2. Thermal Resistance<sup>(Note 4)</sup>

Table 4-2 Thermal Resistance

Parameter	Symbol	Thermal Resistance (Typ)		Unit
		1s <sup>(Note 6)</sup>	2s2p <sup>(Note 7)</sup>	
UQFN40V5050A				
Junction to Ambient	θ <sub>JA</sub>	125.0	43.0	°C/W
Junction to Top Characterization Parameter <sup>(Note 5)</sup>	Ψ <sub>JT</sub>	21	14	°C/W

(Note 4)Based on JESD51-2A(Still-Air)

(Note 5)The thermal characterization parameter to report the difference between junction temperature and the temperature at the top center of the outside surface of the component package.

(Note 6)Using a PCB board based on JESD51-3.

Layer Number of Measurement Board	Material	Board Size
Single	FR-4	114.3mm x 76.2mm x 1.57mm

Top	
Copper Pattern	Thickness
Footprints and Traces	70µm

(Note 7)Using a PCB board based on JESD51-5, 7.

Layer Number of Measurement Board	Material	Board Size	Thermal Via <sup>(Note 8)</sup>	
			Pitch	Diameter
4 Layers	FR-4	114.3mm x 76.2mm x 1.6mm	1.20mm	Φ0.30mm

Top		2 Internal Layers		Bottom	
Copper Pattern	Thickness	Copper Pattern	Thickness	Copper Pattern	Thickness
Footprints and Traces	70µm	74.2mm x 74.2mm	35µm	74.2mm x 74.2mm	70µm

(Note 8) This thermal via connects with the copper pattern of all layers.

4.3. Recommended Operating Conditions

Table 4-3 Recommended Operating Conditions

(Ta=25°C)

Item	Symbol	Range	Unit	Conditions
VB, VEX Voltage	VB, VEX	4.75 to 20	V	
VSVR Voltage	VSVR	-0.1 to 0.1	V	Connect to Ground
VDDIO Voltage	VDDIO	1.7 to 5.5	V	Connect to VCCIN
VCONN_IN Input Voltage	VCONN	4.75 to 5.5	V	
Operating Temperature Range	Topr	-30 to +105	°C	

4.4. Internal Memory Cell Characteristics

Table 4-4 Internal Memory Cell Characteristics

(Ta=25°C, VB=VEX=4.75 to 20V, VSVR=0V)

Item	Limit			Unit	Conditions
	Min	Typ	Max		
Data rewriting number <i>(Note 9)</i>	1000	-	-	time	Ta ≤ 25°C
	100	-	-	time	Ta ≤ 105°C
Data retention life <i>(Note 9)</i>	20	-	-	year	Ta ≤ 25°C
	10	-	-	year	Ta ≤ 105°C

*(Note 9)* Not 100% TESTED

**Caution:** Customer is permitted to rewrite EEPROM on BM92A21 only in case of being provided technical support from ROHM.

4.5. Circuit Power Characteristics

Table 4-5 Common Characteristics

Electrical Characteristics (Ta=25°C)

Item	Symbol	Limit			Unit	Conditions
		Min	Typ	Max		
[Circuit Power]						
Sleep power <i>(Note 10)</i>	PST	-	0.9	-	mW	VSVR=0V, VB=open, VEX=5V, VDDIO=VCCIN
Standby power <i>(Note 11)</i>	POP	-	6	-	mW	VSVR=0V, VB=open, VEX=5V, VDDIO=VCCIN

*(Note 10)* Sleep power: Power consumption at unattached plug.

*(Note 11)* Standby power: Power consumption at attached plug.

## 4.6. Digital Pin DC Characteristics

Table 4-6 Digital Pin DC Characteristics

Electrical Characteristics (Ta=25°C, VSVR=3.3V, VB=open, VEX=open, VDDIO=3.3V)

Item	Symbol	Limit			Unit	Comment
		Min	Typ	Max		
Digital characteristics (VDDIO Power:GPIO0, GPIO1, SMDATA, SMCLK)						
Input "H" level	VIH1	0.8× VDDIO	-	VDDIO+ 0.3	V	
Input "L" level	VIL1	-0.3	-	0.2× VDDIO	V	
Input leak current	IIC1	-5	0	5	μA	Power: VDDIO
Output Voltage when "H"	VOH1	0.7× VDDIO	-	-	V	Source=1mA
SMDATA pin "L" level voltage (SMDATA)	VOL SMDATA	-	-	0.4	V	Sink=350μA Max
Output Voltage when "L" (GPIO0, GPIO1)	VOL1	-	-	0.3	V	Sink=1mA
Digital characteristics (VCCIN Power: XRST, GPIO4, GPIO5, GPIO6, GPIO7)						
Input "H" level	VIH2	0.8× VCCIN	-	VCCIN+ 0.3	V	
Input "L" level	VIL2	-0.3	-	0.2× VCCIN	V	
Input leak current	IIC2	-5	0	5	μA	Power: VCCIN
Output Voltage when "H" (GPIOs)	VOH2	0.7× VCCIN	-	-	V	Source=1mA
Output Voltage when "L" (GPIOs)	VOL2	-	-	0.3	V	Sink=1mA

4.7. Power Supply Management

4.7.1. Outline

BM92A21 has a power selector. It select the lowest power supply voltage from VSVR, VEX, or VB for low power consumption. Internal Power Supply (VCCIN) gives priority in order of VSVR, VEX, and VB. VCCIN supplied from the power selector is used to BM92A21 main power source. LDOs (for internal only) are supplied from VCCIN, and output each internal supply voltage.

Each power supply input have UVLO and OVLO. And POR (power on reset) signal is generated from detection of LDO28OK, LDO15DOK, LDO15AOK, and VCCIN.

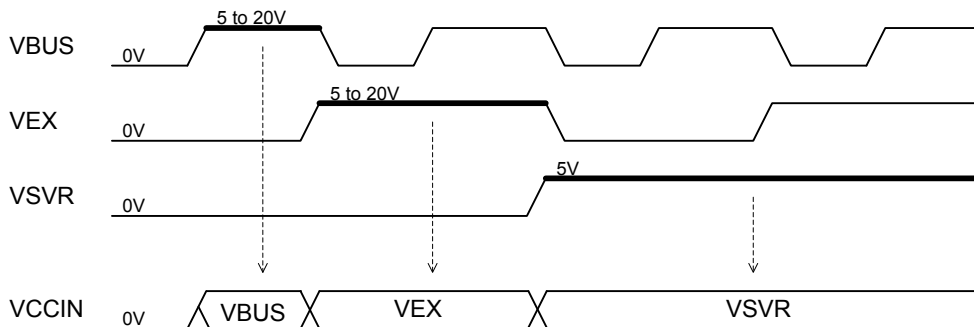
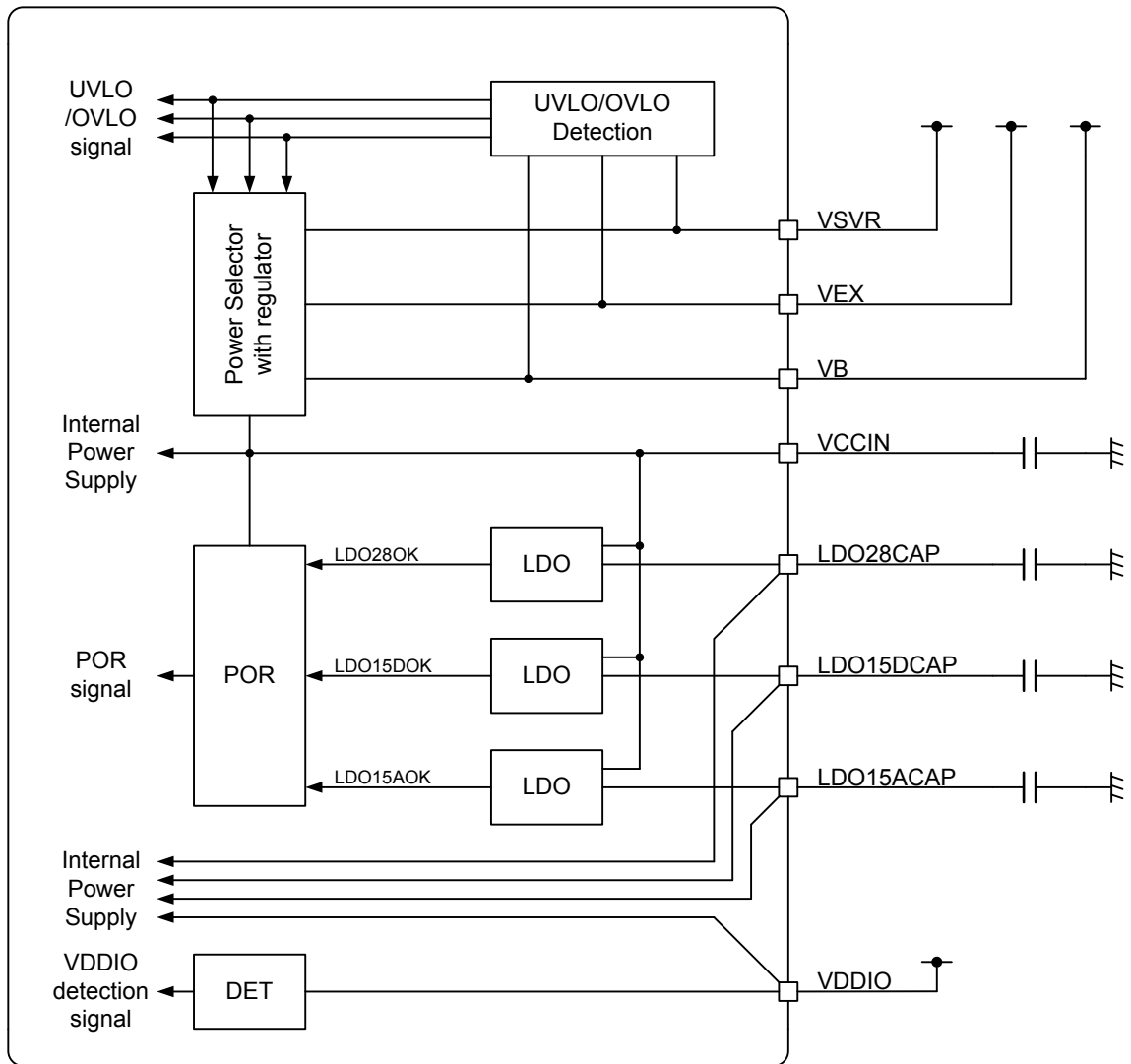

Figure 4-1 Power Supply Management Block Diagram and Timing Chart

## 4.7.2. Electrical Characteristics

Table 4-7 Power Supply Management Characteristics

Item	Symbol	Limit			Unit	Comment
		Min	Typ	Max		
[Analog characteristics] Unless otherwise specified Ta=25°C, GND=0V, C <sub>VCCIN</sub> =4.7μF(Ceramic), C <sub>LDO28</sub> =C <sub>LDO15D</sub> =C <sub>LDO15A</sub> =1μF(Ceramic) Input Analog Pins: VSVR, VEX, VB						
UVLO rising threshold voltage 1	VUVLO1H	-	2.8	-	V	VSVR
UVLO rising threshold voltage 2	VUVLO2H	-	3.5	-	V	VEX, VB
UVLO falling threshold voltage	VUVLOL	-	2.7	-	V	VSVR, VEX, VB
OVLO rising threshold voltage	VOVLO5	-	6.4	-	V	VSVR
OVLO rising threshold voltage	VOVLO20	-	28	-	V	VEX, VB
OVLO hysteresis voltage 1	VOV5HYS	-	240	-	mV	VSVR
OVLO hysteresis voltage 2	VOV20HYS	-	920	-	mV	VEX, VB
Power ON reset threshold voltage	VPOR	-	2.6	-	V	VCCIN
VDDIO detection voltage	VDB	1.7	-	-	V	For Dead Battery Operation
LDO28CAP output voltage	V28	-	2.8	-	V	No Load, VEX=5V
LDO15DCAP output voltage	V15D	-	1.5	-	V	No Load, VEX=5V
LDO15ACAP output voltage	V15A	-	1.5	-	V	No Load, VEX=5V

4.8. CC\_PHY

4.8.1. Outline

CC\_PHY has below functions of USB Type-C. (Refer to USB Type-C Spec)

- Defining Port Mode
  - > DFP Mode Condition
- DFP-to-UFP Attach / Detach Detection
- Plug Orientation / Cable Twist Detection
- USB Type-C VBUS Voltage Detection and Usage
- VCONN (Supply for SOP') Control
- Base-Band Power Delivery Communication (BBPD communication)

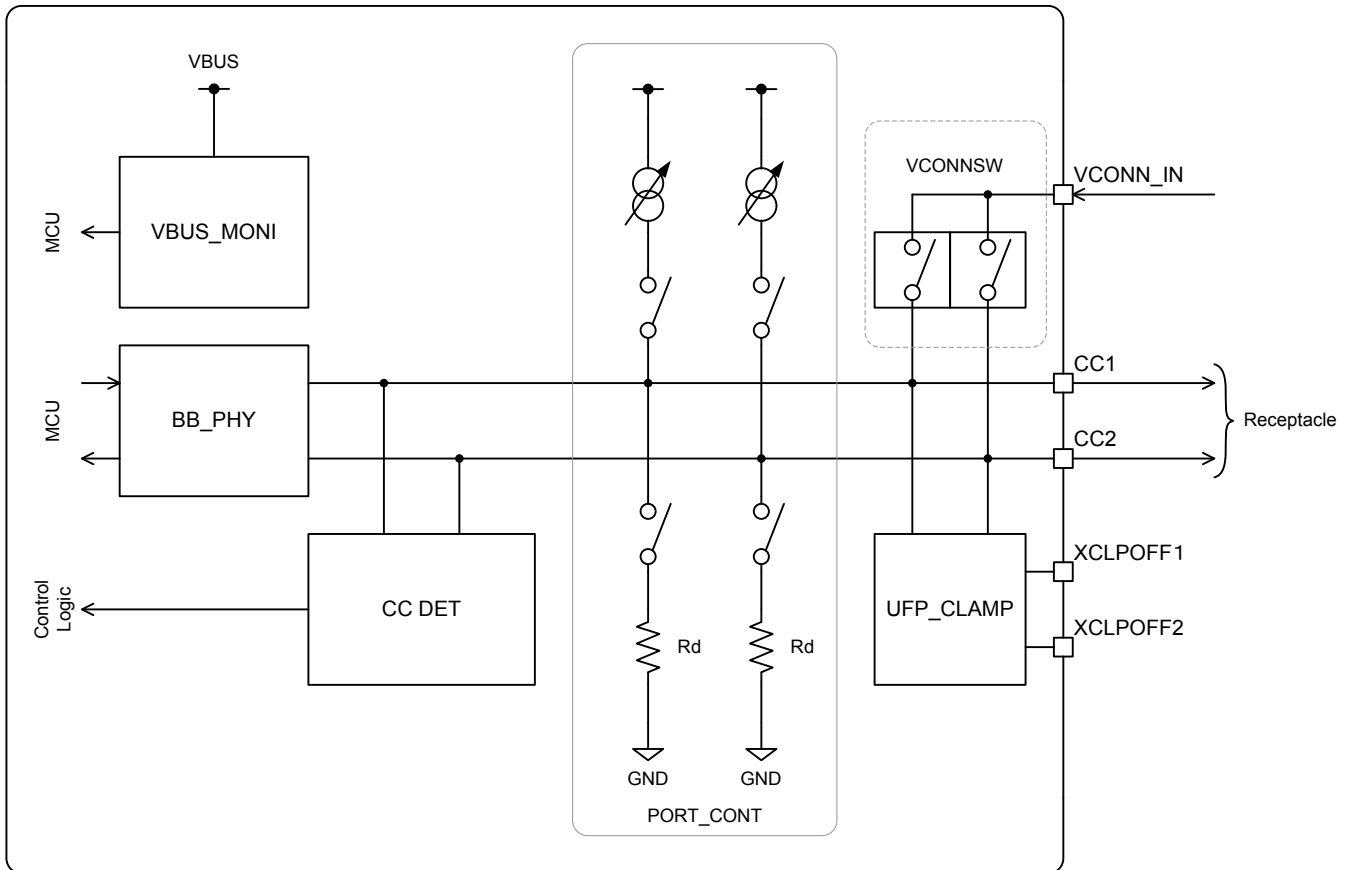

Figure 4-2 CC\_PHY Block Diagram

[PORT\_CONT]

This block is fixed DFP mode.

(DFP)

Variable current source is connected to CC terminal. These currents of each mode are Default Current, Medium Current and High Current.

[CC\_DET]

CC\_DET has functions of "Attach / Detach Detection", "Plug Orientation / Cable Twist Detection", "Discovery and detect extension mode" and "USB Type-C VBUS Current Detection".

Attach / Detach is detected with monitoring voltage of CC terminal. When the voltage of CC terminal become under a threshold voltage at DFP, attach is detected. Oppositely, when the voltage of CC terminal become over a threshold voltage, detach is detected.

Plug orientation and cable twist is detected from the relationship of two CC terminals. Because only one wire is connected to Rd, the difference between two CC terminals is generated.

[VBUS\_MONI]

UFP detect Attach / Detach by existence of VBUS voltage. VBUSDET detects Attach when VBUS voltage over the threshold voltage. And it detects Detach when VBUS under the threshold voltage.

[VCONNSW]

VCONNSW is the power switch for VCONN source. It has OCP function.

[BB\_PHY]

If Type-C controller supports BBPD, CC terminal can output BBPD communication signal. (Refer to BB\_PHY)

4.8.2. Electrical Characteristics

Table 4-8 CC\_PHY Characteristics

Item	Symbol	Limit			Unit	Comment
		Min	Typ	Max		
[PORT_CONT characteristics] Unless otherwise specified Ta=25°C, VEX=5V, VCONN_IN=open, VDDIO=VCCIN, GND=0V, C <sub>VCCIN</sub> =4.7μF(Ceramic), C <sub>LDO28</sub> =C <sub>LDO15D</sub> =C <sub>LDO15A</sub> =1μF(Ceramic) Input Analog Pins: CC1, CC2						
Default current	CCPUP1	64	80	96	μA	
Medium current	CCPUP2	166	180	194	μA	
High current	CCPUP3	304	330	356	μA	
Pull down resistor	CCPDN	4.6	5.1	5.6	kΩ	
[UFP_CLAMP characteristics] Unless otherwise specified Ta=25°C, VEX=5V, VCONN_IN=open, VDDIO=VCCIN, GND=0V, C <sub>VCCIN</sub> =4.7μF(Ceramic), C <sub>LDO28</sub> =C <sub>LDO15D</sub> =C <sub>LDO15A</sub> =1μF(Ceramic) Input Analog Pins: CC1, CC2						
CCx terminal input impedance	CCZin	126	-	-	kΩ	
CCx clamp voltage	CCCLP	0.7	-	1.3	V	I <sub>in</sub> =64 to 356μA
[VBUS_MONI] Unless otherwise specified Ta=25°C, VEX=5V, VCONN_IN=open, VDDIO=VCCIN, GND=0V, C <sub>VCCIN</sub> =4.7μF(Ceramic), C <sub>LDO28</sub> =C <sub>LDO15D</sub> =C <sub>LDO15A</sub> =1μF(Ceramic) Input Analog Pins: VB						
VBUS presence detection level	CCVBDET	-	3.42	-	V	
[VCONNSW] Unless otherwise specified Ta=25°C, VEX=5V, VCONN_IN=5V, VDDIO=VCCIN, GND=0V, C <sub>VCCIN</sub> =4.7μF(Ceramic), C <sub>LDO28</sub> =C <sub>LDO15D</sub> =C <sub>LDO15A</sub> =1μF(Ceramic) Input Analog Pins: CC1, CC2, VCONN_IN						
VCONN_IN to CCx resistance	CCVCR	-	-	500	mΩ	
Overcurrent protection level	CCVCOCP	1.1	-	-	A	

4.9. Voltage Detection

4.9.1. Outline

VDET Block detects the voltage level of VB. It can detect follow conditions;  
 -OVP (over voltage protection) detection  
 -VBUS voltage drop detection

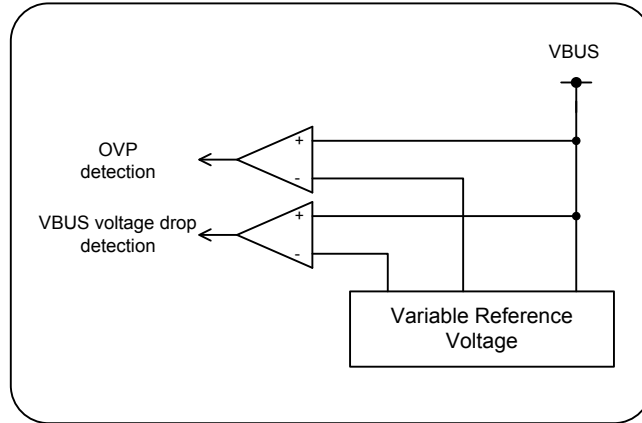

Figure 4-3 Voltage Detection Block Diagram

4.9.2. Electrical Characteristics

Table 4-9 Voltage Detection characteristics

Item	Symbol	Limit			Unit	Comment
		Min	Typ	Max		
[VDET characteristics] Unless otherwise specified Ta=25°C, VEX=5V, VCONN_IN=5V, VDDIO=VCCIN, GND=0V, CVCCIN=4.7μF(Ceramic), CLDO28=CLDO15D=CLDO15A=1μF(Ceramic), Vnom=PD negotiation Voltage Input Analog Pins: VB						
Over voltage protection detection rate	OVP	17	20	23	%	Standard voltage=Vnom
VBUS voltage drop detection rate	VB_DROP	-27	-25	-23	%	Standard voltage=Vnom

4.10. VBUS Discharge

4.10.1. Outline

NMOS switch is prepared for VBUS discharging.

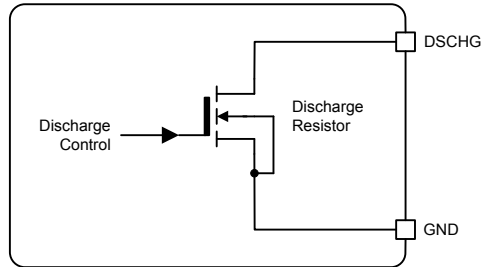

Figure 4-4 VBUS Discharge Block Diagram

4.10.2. Electrical Characteristics

Table 4-10 VBUS Discharge Characteristics

Item	Symbol	Limit			Unit	Comment
		Min	Typ	Max		
[Discharge characteristics] Unless otherwise specified Ta=25°C, VEX=5V, VCONN_IN=5V, VDDIO=VCCIN, GND=0V, C <sub>VCCIN</sub> =4.7μF(Ceramic), C <sub>LDO28</sub> =C <sub>LDO15D</sub> =C <sub>LDO15A</sub> =1μF(Ceramic) Input Analog Pins: DSCHG						
MOSFET Switch ON Resistance	RDSCHG	-	25	-	Ω	

4.11. Power FET Gate Driver (Power Path and Discharge)

4.11.1. Outline

FET Gate Driver is the NMOS switch driver for power line and discharging switch.  
 - External Nch-FET gate control: SPDSRC, LDISCHG

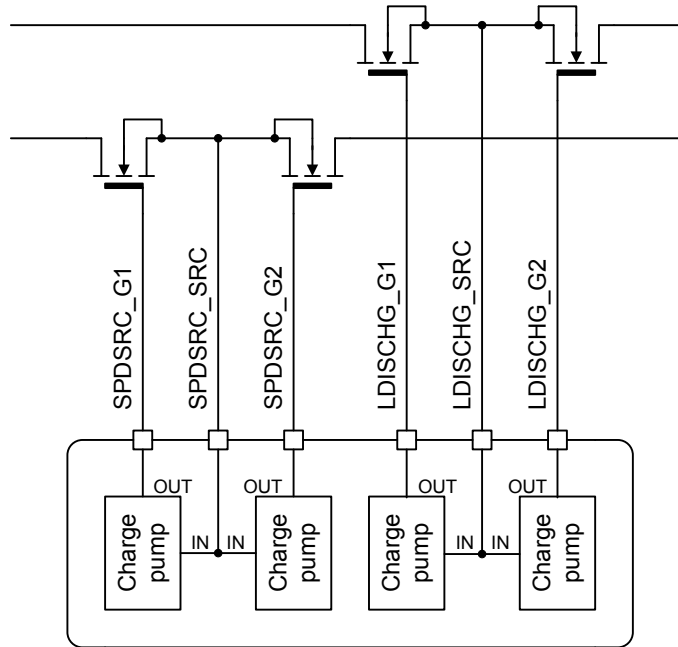

Figure 4-5 Power FET Gate Driver Block Diagram

4.11.2. Electrical Characteristics

Table 4-11 Power FET Gate Driver Characteristics

Item	Symbol	Limit			Unit	Comment
		Min	Typ	Max		
[Discharge characteristics] Unless otherwise specified Ta=25°C, VEX=5V, VCONN_IN=5V, VDDIO=VCCIN, GND=0V, C <sub>VCCIN</sub> =4.7μF(Ceramic), C <sub>LDO28</sub> =C <sub>LDO15D</sub> =C <sub>LDO15A</sub> =1μF(Ceramic) Input Analog Pins: SPDSRC_SRC, LDISCHG_SRC=0V Output Analog Pins: SPDSRC_G1, SPDSRC_G2, LDISCHG_G1, LDISCHG_G2						
FET control voltage between gate and source	VGS	-	6.0	-	V	SPDSRC_G1 – SPDSRC_SRC SPDSRC_G2 – SPDSRC_SRC LDISCHG_G1 – LDISCHG_SRC LDISCHG_G2 – LDISCHG_SRC

4.12. ACDC Bridge

4.12.1. Outline

ACDC Bridge Block has an error amplifier and current sensing comparator.

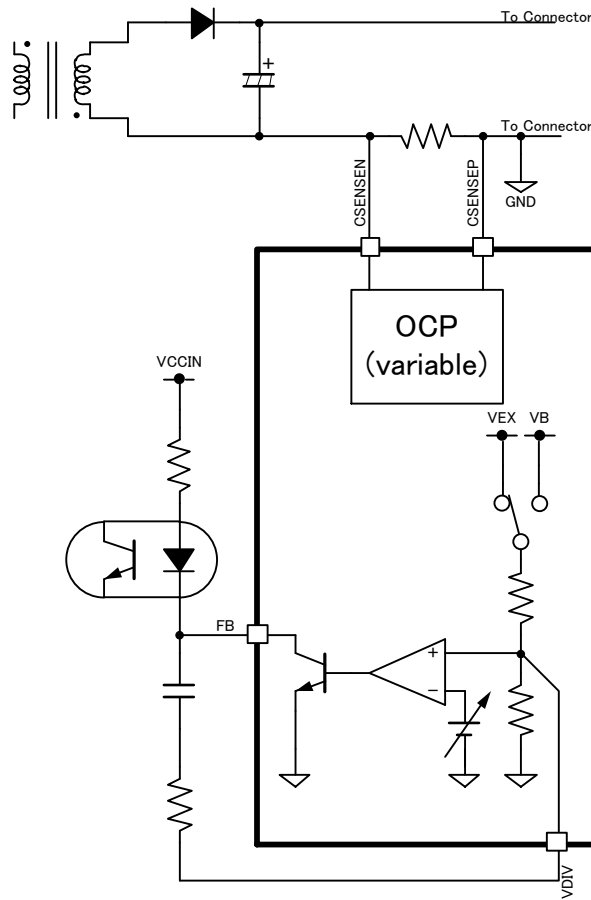

Figure 4-6 ACDC Bridge Block Diagram

4.12.2. Electrical Characteristics

Table 4-12 ACDC Bridge Characteristics

Item	Symbol	Limit			Unit	Comment
		Min	Typ	Max		
[Discharge characteristics] Unless otherwise specified Ta=25°C, VEX=5V, VCONN_IN=VCCIN, VDDIO=VCCIN, GND=0V, CVCCIN=4.7μF(Ceramic), CLDO28=CLDO15D=CLDO15A=1μF(Ceramic) Input Analog Pins: VEX,CSENSE, CSENCE Output Analog Pins: FB, VDIV (Vnom=PDO setting voltage, Inom=PDO setting current)						
PDO voltage setting range	BRDV R	5	-	20	V	
PDO voltage setting step	BRDV S	-	50	-	mV	
PDO1 setting voltage	VPDO1	-	5	-	V	
PDO2 setting voltage	VPDO2	-	9	-	V	
PDO3 setting voltage	VPDO3	-	12	-	V	
PDO4 setting voltage	VPDO4	-	15	-	V	
PDO5 setting voltage	VPDO5	-	20	-	V	
Feedback current threshold voltage (PDO=Vnom)	BRDV TH	Vnom -2%	Vnom	Vnom +2%	V	VEX= Rise
Trans conductance	BRDV TC	-	1	-	S	ΔIFB/ΔVEX
Maximum feedback current	BRDV Imax	2	-	-	mA	
PDO current setting range	BRDV IR	0	-	5	A	

PDO current setting step	BRDIS	-	10	-	mA	
PDO1 setting current	Inom1	-	3	-	A	
PDO2 setting current	Inom2	-	3	-	A	
PDO3 setting current	Inom3	-	3	-	A	
PDO4 setting current	Inom4	-	3	-	A	
PDO5 setting current	Inom5	-	5	-	A	
Current sense detecting rate <sup>(NOTE12)</sup> (PDO=Inom)	BRDCCS	-	Inom X1.2	-	A	Inom: Negotiated current

(NOTE12)Minimum BRDCCS value is 1.2A. For example, when PDO is 0.5A, BRDCCS value is not 0.5A × 1.2, BRDCCS value is 1.2A.

4.13. Power On Sequence

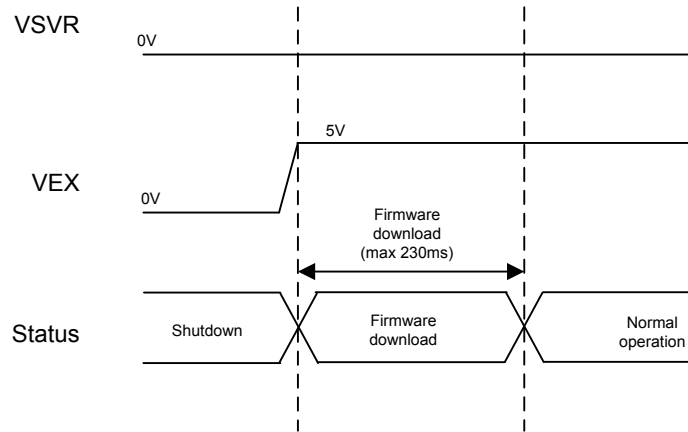

Figure 4-6 Power On Sequence

4.13.1. Reset Timing

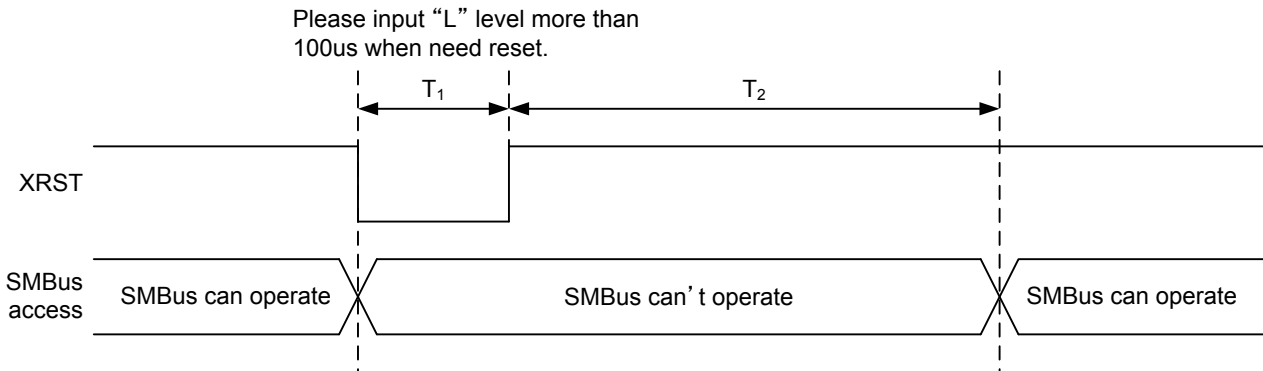

Figure 4-7 Reset Timing Chart

Table 4-13 Reset Timing Characteristics

Item	Symbol	Limit			Unit	Comment
		Min	Typ	Max		
Reset Timing						
XRST Minimum Pulse	T1	100	-	-	μs	
SMBus access Start after XRST release	T2	230	-	-	ms	

4.14. Power Off Sequence

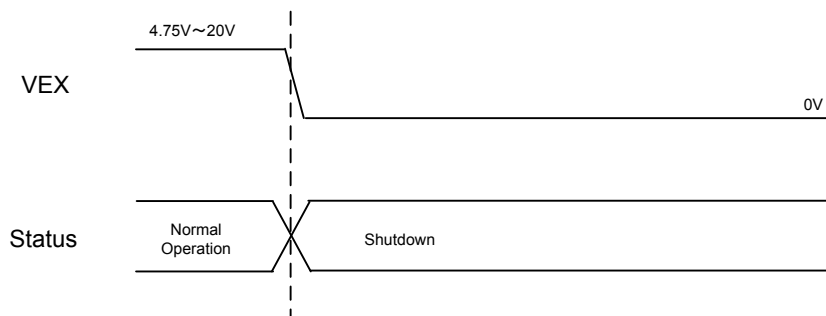

Figure 4-8 Power Off Sequence

4.15. I/O Equivalence Circuit

PIN No.	PIN Name	Equivalent circuit diagram
5 6 9 28	VCCIN VSVR VB VEX	
7	DSCHG	
16 17 15 14  10 11 12 13	GPIO0 GPIO1 DBGMODDT DBGRSTCK  GPIO4 GPIO5 GPIO6 GPIO7	
29	VDIV	

PIN No.	PIN Name	Equivalent circuit diagram
30	FB	
18	VDDIO	
32 31	CSENSEP CSENSEN	
19 21	SMDATA SMCLK	
32 22 23 24 25 26	LDISCHG_G1 LDISCHG_SRC LDISCHG_G2 SPDSRC_G1 SPDSRC_SRC SPDSRC_G2	

PIN No.	PIN Name	Equivalent circuit diagram
33 34 35 36 37	XCLPOFF1 XCLPOFF2 CC1 VCONN_IN CC2	
4	XRST	
38 40	LDO15DCAP LDO15ACAP	
39	LDO28CAP	

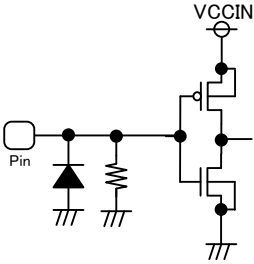
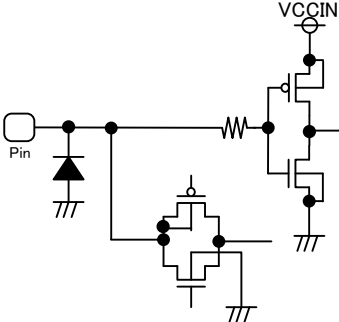
PIN No.	PIN Name	Equivalent circuit diagram
2	VSTR/ATST2	
3	IDSEL/ATST1	

5. Application Example

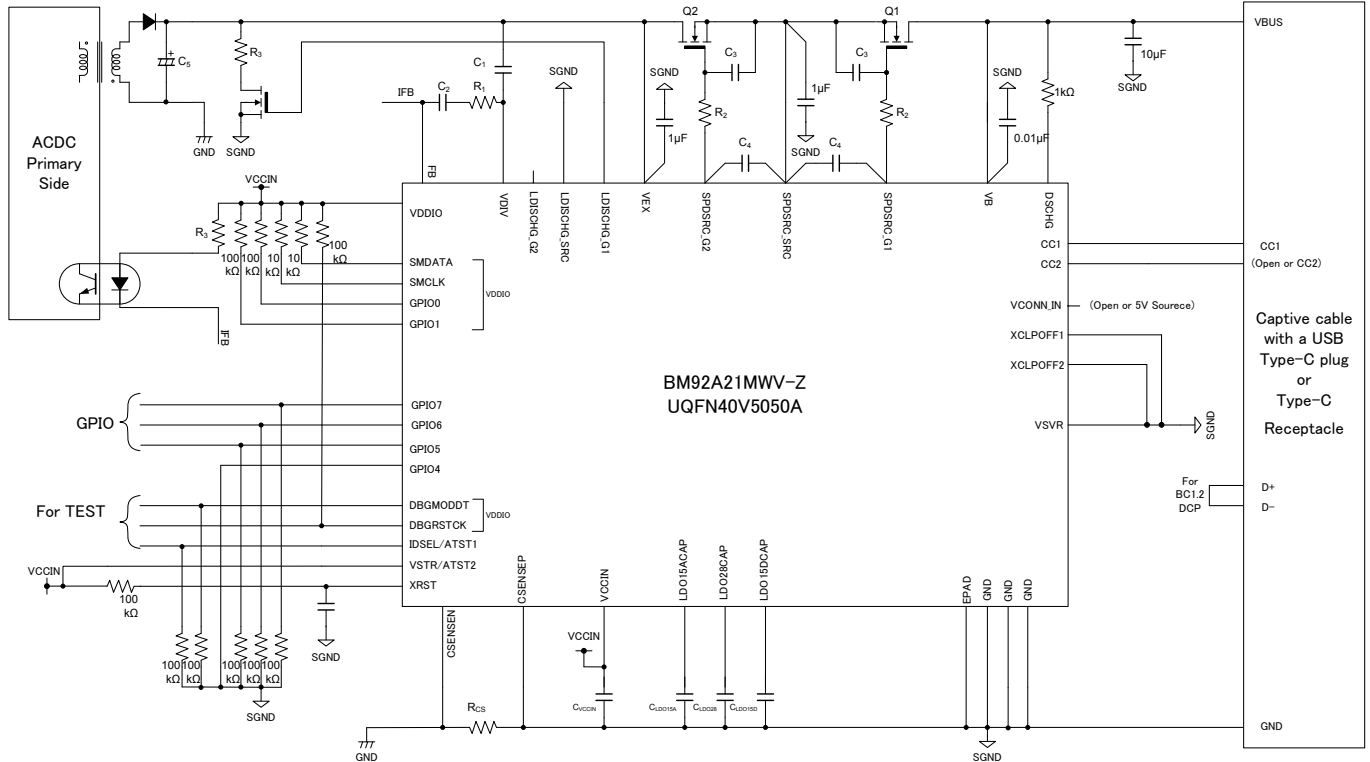

Figure 5-1 Application Example

5.1. Selection of Components Externally connected

Table 5-1 Selection of Components Externally Connected

Item	Symbol	Limit			Unit	Comment
		Min	Typ	Max		
VCCIN Capacitance <sup>(Note 13)</sup>	C <sub>VCCIN</sub>	0.60	4.7	10	μF	
LDO15ACAP Capacitance <sup>(Note 13)</sup>	C <sub>LDO15A</sub>	0.47	1.0	2.2	μF	
LDO15DCAP Capacitance <sup>(Note 13)</sup>	C <sub>LDO15D</sub>	0.47	1.0	2.2	μF	
LDO28CAP Capacitance <sup>(Note 13)</sup>	C <sub>LDO28</sub>	0.47	1.0	2.2	μF	
Q1,Q2 Gate-Source Capacitance	C <sub>Qx_gs</sub>	470p	-	0.5μ	F	
System Phase Compensation Capacitance 1 <sup>(Note13)</sup>	C <sub>1</sub>	-	-	-	F	Please choose the value suitable for your ACDC system.
System Phase Compensation Capacitance 2 <sup>(Note13)</sup>	C <sub>2</sub>	-	-	-	F	
Capacitance for the VBUS setup timing <sup>(Note13)</sup>	C <sub>3</sub>	-	-	-	F	Please choose the value suitable for your ACDC system.
Phase Compensation Capacitance <sup>(Note13)</sup>	C <sub>4</sub>	470p	-	0.5μ	F	In the case of R2≠0. If R2 is 0Ω, please coordinate C4 so that sum total of C3 and CQ and C4 is in the limit.
Current Sensing Resistor	R <sub>Cs</sub>	-	10	-	mΩ	This resistance tolerance influences OCP detection accuracy. Please choose the value that you can permit.
System Phase Compensation Resistance	R <sub>1</sub>	-	-	-	Ω	Please choose the value suitable for your ACDC system.
Resistance for the VBUS setup timing	R <sub>2</sub>	-	-	-	Ω	Please choose the value suitable for your ACDC system.
ACDC Feedback Current Limit Resistor	R <sub>3</sub>	-	-	-	Ω	Please choose the value suitable for your ACDC system.

(Note 13) Please set the capacity of the condenser not to be less than the minimum in consideration of temperature properties, DC bias properties.

**6. Firmware Revision**

Firmware Revision	1565h
-------------------	-------

## 7. Operational Notes

### (1) Reverse Connection of Power Supply

Connecting the power supply in reverse polarity can damage the IC. Take precautions against reverse polarity when connecting the power supply, such as mounting an external diode between the power supply and the IC's power supply pins.

### (2) Power Supply Lines

Design the PCB layout pattern to provide low impedance supply lines. Separate the ground and supply lines of the digital and analog blocks to prevent noise in the ground and supply lines of the digital block from affecting the analog block. Furthermore, connect a capacitor to ground at all power supply pins. Consider the effect of temperature and aging on the capacitance value when using electrolytic capacitors.

### (3) Ground Voltage

Ensure that no pins are at a voltage below that of the ground pin at any time, even during transient condition.

### (4) Ground Wiring Pattern

When using both small-signal and large-current ground traces, the two ground traces should be routed separately but connected to a single ground at the reference point of the application board to avoid fluctuations in the small-signal ground caused by large currents. Also ensure that the ground traces of external components do not cause variations on the ground voltage. The ground lines must be as short and thick as possible to reduce line impedance.

### (5) Thermal Consideration

Should by any chance the power dissipation rating be exceeded the rise in temperature of the chip may result in deterioration of the properties of the chip. In case of exceeding this absolute maximum rating, increase the board size and copper area to prevent exceeding the Pd rating.

### (6) Recommended Operating Conditions

These conditions represent a range within which the expected characteristics of the IC can be approximately obtained. The electrical characteristics are guaranteed under the conditions of each parameter.

### (7) Inrush Current

When power is first supplied to the IC, it is possible that the internal logic may be unstable and inrush current may flow instantaneously due to the internal powering sequence and delays, especially if the IC has more than one power supply. Therefore, give special consideration to power coupling capacitance, power wiring, width of ground wiring, and routing of connections.

### (8) Operation Under Strong Electromagnetic Field

Operating the IC in the presence of a strong electromagnetic field may cause the IC to malfunction.

### (9) Testing on Application Boards

When testing the IC on an application board, connecting a capacitor directly to a low-impedance output pin may subject the IC to stress. Always discharge capacitors completely after each process or step. The IC's power supply should always be turned off completely before connecting or removing it from the test setup during the inspection process. To prevent damage from static discharge, ground the IC during assembly and use similar precautions during transport and storage.

Operational Notes – continued

(10) Inter-pin Short and Mounting Errors

Ensure that the direction and position are correct when mounting the IC on the PCB. Incorrect mounting may result in damaging the IC. Avoid nearby pins being shorted to each other especially to ground, power supply and output pin. Inter-pin shorts could be due to many reasons such as metal particles, water droplets (in very humid environment) and unintentional solder bridge deposited in between pins during assembly to name a few.

(11) Unused Input Pins

Input pins of an IC are often connected to the gate of a MOS transistor. The gate has extremely high impedance and extremely low capacitance. If left unconnected, the electric field from the outside can easily charge it. The small charge acquired in this way is enough to produce a significant effect on the conduction through the transistor and cause unexpected operation of the IC. So unless otherwise specified, unused input pins should be connected to the power supply or ground line.

(12) Regarding the Input Pin of the IC

This monolithic IC contains P+ isolation and P substrate layers between adjacent elements in order to keep them isolated. P-N junctions are formed at the intersection of the P layers with the N layers of other elements, creating a parasitic diode or transistor. For example (refer to figure below):

When  $GND > Pin A$  and  $GND > Pin B$ , the P-N junction operates as a parasitic diode.

When  $GND > Pin B$ , the P-N junction operates as a parasitic transistor.

Parasitic diodes inevitably occur in the structure of the IC. The operation of parasitic diodes can result in mutual interference among circuits, operational faults, or physical damage. Therefore, conditions that cause these diodes to operate, such as applying a voltage lower than the GND voltage to an input pin (and thus to the P substrate) should be avoided.

Figure xx. Example of monolithic IC structure

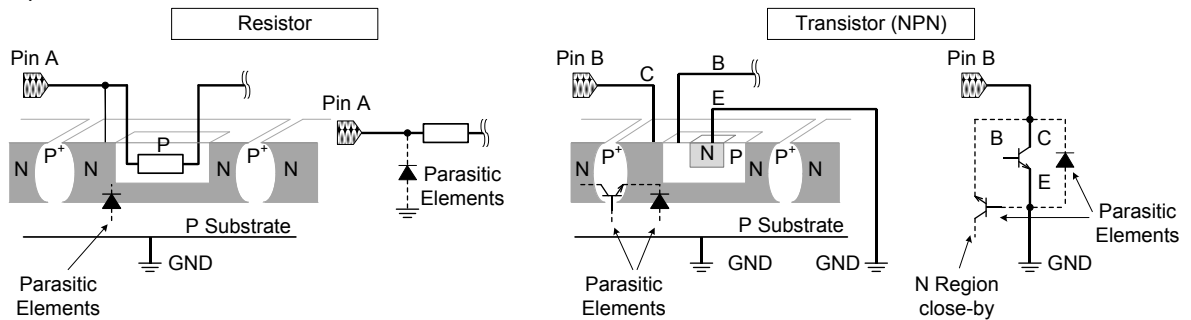

(13) Ceramic Capacitor

When using a ceramic capacitor, determine the dielectric constant considering the change of capacitance with temperature and the decrease in nominal capacitance due to DC bias and others.

(14) Area of Safe Operation (ASO)

Operate the IC such that the output voltage, output current, and power dissipation are all within the Area of Safe Operation(ASO)

(15) Over Current Protection Circuit (OCP)

This IC incorporates an integrated overcurrent protection circuit that is activated when the load is shorted. This protection circuit is effective in preventing damage due to sudden and unexpected incidents. However, the IC should not be used in applications characterized by continuous operation or transitioning of the protection circuit.

8. Ordering Information

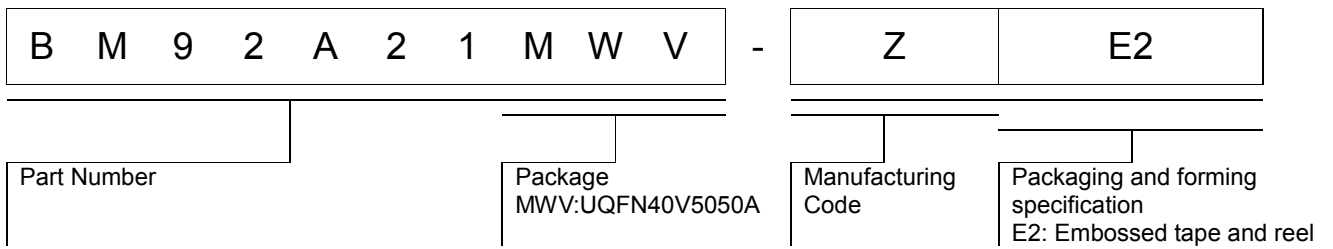

9. Marking Diagrams

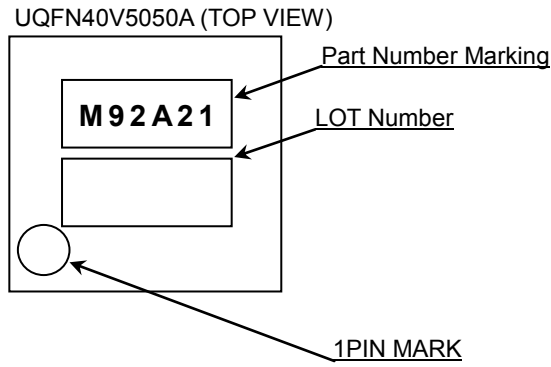

10. Physical Dimension Tape and Reel Information

Package Name	UQFN40V5050A
--------------	--------------

(UNIT: mm)

PKG: UQFN40V5050A  
Drawing No. EX001-0014

**<Tape and Reel information>**

<b>Tape</b>	Embossed carrier tape
<b>Quantity</b>	2500pcs
<b>Direction of feed</b>	E2 (The direction is the 1pin of product is at the upper left when you hold reel on the left hand and you pull out the tape on the right hand)

\* Order quantity needs to be multiple of the minimum quantity.

**11. Revision History**

Date	Revision	Changes
31.Mar.2017	001	New Release

# Notice

## Precaution on using ROHM Products

- Our Products are designed and manufactured for application in ordinary electronic equipments (such as AV equipment, OA equipment, telecommunication equipment, home electronic appliances, amusement equipment, etc.). If you intend to use our Products in devices requiring extremely high reliability (such as medical equipment <sup>(Note 1)</sup>, transport equipment, traffic equipment, aircraft/spacecraft, nuclear power controllers, fuel controllers, car equipment including car accessories, safety devices, etc.) and whose malfunction or failure may cause loss of human life, bodily injury or serious damage to property ("Specific Applications"), please consult with the ROHM sales representative in advance. Unless otherwise agreed in writing by ROHM in advance, ROHM shall not be in any way responsible or liable for any damages, expenses or losses incurred by you or third parties arising from the use of any ROHM's Products for Specific Applications.

(Note1) Medical Equipment Classification of the Specific Applications

JAPAN	USA	EU	CHINA
CLASS III	CLASS III	CLASS II b	CLASS III
CLASS IV		CLASS III	

- ROHM designs and manufactures its Products subject to strict quality control system. However, semiconductor products can fail or malfunction at a certain rate. Please be sure to implement, at your own responsibilities, adequate safety measures including but not limited to fail-safe design against the physical injury, damage to any property, which a failure or malfunction of our Products may cause. The following are examples of safety measures:
  - Installation of protection circuits or other protective devices to improve system safety
  - Installation of redundant circuits to reduce the impact of single or multiple circuit failure
- Our Products are designed and manufactured for use under standard conditions and not under any special or extraordinary environments or conditions, as exemplified below. Accordingly, ROHM shall not be in any way responsible or liable for any damages, expenses or losses arising from the use of any ROHM's Products under any special or extraordinary environments or conditions. If you intend to use our Products under any special or extraordinary environments or conditions (as exemplified below), your independent verification and confirmation of product performance, reliability, etc. prior to use, must be necessary:
  - Use of our Products in any types of liquid, including water, oils, chemicals, and organic solvents
  - Use of our Products outdoors or in places where the Products are exposed to direct sunlight or dust
  - Use of our Products in places where the Products are exposed to sea wind or corrosive gases, including Cl<sub>2</sub>, H<sub>2</sub>S, NH<sub>3</sub>, SO<sub>2</sub>, and NO<sub>2</sub>
  - Use of our Products in places where the Products are exposed to static electricity or electromagnetic waves
  - Use of our Products in proximity to heat-producing components, plastic cords, or other flammable items
  - Sealing or coating our Products with resin or other coating materials
  - Use of our Products without cleaning residue of flux (even if you use no-clean type fluxes, cleaning residue of flux is recommended); or Washing our Products by using water or water-soluble cleaning agents for cleaning residue after soldering
  - Use of the Products in places subject to dew condensation
- The Products are not subject to radiation-proof design.
- Please verify and confirm characteristics of the final or mounted products in using the Products.
- In particular, if a transient load (a large amount of load applied in a short period of time, such as pulse. is applied, confirmation of performance characteristics after on-board mounting is strongly recommended. Avoid applying power exceeding normal rated power; exceeding the power rating under steady-state loading condition may negatively affect product performance and reliability.
- De-rate Power Dissipation depending on ambient temperature. When used in sealed area, confirm that it is the use in the range that does not exceed the maximum junction temperature.
- Confirm that operation temperature is within the specified range described in the product specification.
- ROHM shall not be in any way responsible or liable for failure induced under deviant condition from what is defined in this document.

## Precaution for Mounting / Circuit board design

- When a highly active halogenous (chlorine, bromine, etc.) flux is used, the residue of flux may negatively affect product performance and reliability.
- In principle, the reflow soldering method must be used on a surface-mount products, the flow soldering method must be used on a through hole mount products. If the flow soldering method is preferred on a surface-mount products, please consult with the ROHM representative in advance.

For details, please refer to ROHM Mounting specification

### Precautions Regarding Application Examples and External Circuits

1. If change is made to the constant of an external circuit, please allow a sufficient margin considering variations of the characteristics of the Products and external components, including transient characteristics, as well as static characteristics.
2. You agree that application notes, reference designs, and associated data and information contained in this document are presented only as guidance for Products use. Therefore, in case you use such information, you are solely responsible for it and you must exercise your own independent verification and judgment in the use of such information contained in this document. ROHM shall not be in any way responsible or liable for any damages, expenses or losses incurred by you or third parties arising from the use of such information.

### Precaution for Electrostatic

This Product is electrostatic sensitive product, which may be damaged due to electrostatic discharge. Please take proper caution in your manufacturing process and storage so that voltage exceeding the Products maximum rating will not be applied to Products. Please take special care under dry condition (e.g. Grounding of human body / equipment / solder iron, isolation from charged objects, setting of Ionizer, friction prevention and temperature / humidity control).

### Precaution for Storage / Transportation

1. Product performance and soldered connections may deteriorate if the Products are stored in the places where:
  - [a] the Products are exposed to sea winds or corrosive gases, including Cl<sub>2</sub>, H<sub>2</sub>S, NH<sub>3</sub>, SO<sub>2</sub>, and NO<sub>2</sub>
  - [b] the temperature or humidity exceeds those recommended by ROHM
  - [c] the Products are exposed to direct sunshine or condensation
  - [d] the Products are exposed to high Electrostatic
2. Even under ROHM recommended storage condition, solderability of products out of recommended storage time period may be degraded. It is strongly recommended to confirm solderability before using Products of which storage time is exceeding the recommended storage time period.
3. Store / transport cartons in the correct direction, which is indicated on a carton with a symbol. Otherwise bent leads may occur due to excessive stress applied when dropping of a carton.
4. Use Products within the specified time after opening a humidity barrier bag. Baking is required before using Products of which storage time is exceeding the recommended storage time period.

### Precaution for Product Label

A two-dimensional barcode printed on ROHM Products label is for ROHM's internal use only.

### Precaution for Disposition

When disposing Products please dispose them properly using an authorized industry waste company.

### Precaution for Foreign Exchange and Foreign Trade act

Since concerned goods might be fallen under listed items of export control prescribed by Foreign exchange and Foreign trade act, please consult with ROHM in case of export.

### Precaution Regarding Intellectual Property Rights

1. All information and data including but not limited to application example contained in this document is for reference only. ROHM does not warrant that foregoing information or data will not infringe any intellectual property rights or any other rights of any third party regarding such information or data.
2. ROHM shall not have any obligations where the claims, actions or demands arising from the combination of the Products with other articles such as components, circuits, systems or external equipment (including software).
3. No license, expressly or implied, is granted hereby under any intellectual property rights or other rights of ROHM or any third parties with respect to the Products or the information contained in this document. Provided, however, that ROHM will not assert its intellectual property rights or other rights against you or your customers to the extent necessary to manufacture or sell products containing the Products, subject to the terms and conditions herein.

### Other Precaution



1. This document may not be reprinted or reproduced, in whole or in part, without prior written consent of ROHM.
2. The Products may not be disassembled, converted, modified, reproduced or otherwise changed without prior written consent of ROHM.
3. In no event shall you use in any way whatsoever the Products and the related technical information contained in the Products or this document for any military purposes, including but not limited to, the development of mass-destruction weapons.
4. The proper names of companies or products described in this document are trademarks or registered trademarks of ROHM, its affiliated companies or third parties.

**General Precaution**







1. Before you use our Products, you are requested to carefully read this document and fully understand its contents. ROHM shall not be in any way responsible or liable for failure, malfunction or accident arising from the use of any ROHM's Products against warning, caution or note contained in this document.
2. All information contained in this document is current as of the issuing date and subject to change without any prior notice. Before purchasing or using ROHM's Products, please confirm the latest information with a ROHM sales representative.
3. The information contained in this document is provided on an "as is" basis and ROHM does not warrant that all information contained in this document is accurate and/or error-free. ROHM shall not be in any way responsible or liable for any damages, expenses or losses incurred by you or third parties resulting from inaccuracy or errors of or concerning such information.

## Looking for pricing, stock, or lifecycle information?

Click below to explore more details on WIN SOURCE:

-  [View BM92A21MWV-ZE2 on WIN SOURCE](#)
-  [Rohm Semiconductor](#) Information

## Optimize Your Supply Chain with WIN SOURCE Solutions

-  Global Sourcing Solution
-  Obsolete Management
-  Cost Control Management
-  Shortage Management
-  Alternative Solution
-  Excess Inventory Management