

## FEATURES

- Lowest cost! Highest reliability!
- 100% SMT-on-pcb, including magnetics
- 100% automatically assembled
- Standard "DIP" package and pinouts
- Fully isolated, 1000Vdc guaranteed
- $\pm 5$ ,  $\pm 12$  or  $\pm 15$  Volt outputs
- Choice of 3 wide-range inputs:
  - 4.5-9 Volts
  - 9-18 Volts
  - 18-72 Volts
- Guaranteed efficiencies to 75%
- -40 to +75°C full-power operation
- Internal input/output filtering
- UL1950/C22.2 No. 950/IEC950-1 certified

## PRODUCT OVERVIEW

Rarely, has a Series of low-power DC/DC converters been defined by both low cost and Murata's quality and reliability. Our new BST Series of dual-output 3W DC/DC's achieves this "best-of-both-worlds" status by implementing a proven circuit architecture (170-200kHz flyback design) as a full, SMT-on-pcb assembly (including surface-mount magnetics) that is truly 100% automatically assembled. Packaged in miniature 1.25" x 0.8", DIP-like plastic packages (UL94V-0 rated) and requiring no external components, BST Series DC/DC's bring true component-like convenience to designers of today's distributed power systems.

Output voltages are  $\pm 5$ ,  $\pm 12$  or  $\pm 15$  Volts. Input voltage ranges are 4.5-9V ("D5" models), 9-18V ("D12" models) or an ultra-wide 18-72V ("D48" models). BST DC/DC's are fully isolated (1000Vdc guaranteed) and include input (pi type) and output filters within their package. Output transient response

is a quick 200 $\mu$ sec, while output ripple and noise are typically 75mVp-p.

These rugged modules are fully encapsulated with a thermally conductive potting compound that contributes to their outstanding moisture/vibration resistance and impressive MTBF. They operate over the full -40 to +75°C temperature range without derating. All models have been thoroughly characterized (electrically, mechanically and thermally), qualified (including HALT), and EMI/EMC tested. Additionally, they are certified to UL1950, CSA 22.2 No. 950 and IEC950.

Murata's BST Model 3W DC/DC's are excellent selections for telecom/datacom, computer and process-control applications demanding small size, low cost and high reliability. If required, their design "flexibility" allows for easy modification to your application-specific requirements.

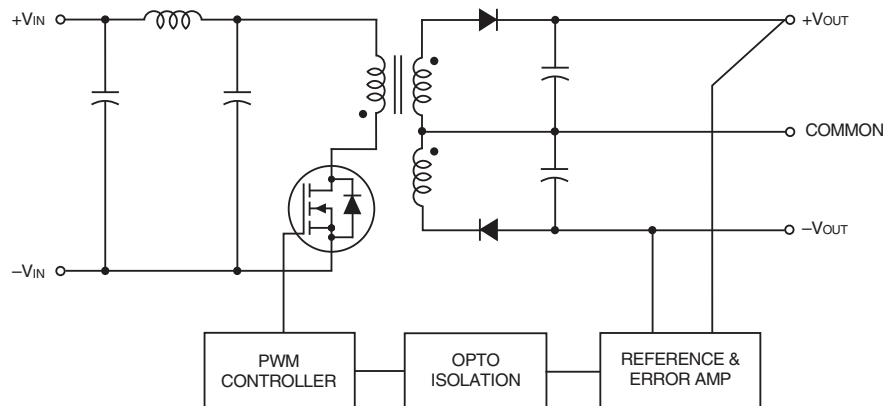

Typical topology is shown.

Figure 1. Simplified Schematic



## Performance Specifications and Ordering Guide<sup>①</sup>

ORDERING GUIDE SUMMARY												
Models	Output				Input			Efficiency		Package (Case, Pinout)		
	V <sub>OUT</sub> (Volts)	I <sub>OUT</sub> (mA Max.)	R/N (mV pk-pk) <sup>②</sup>		Regulation (Max.)		V <sub>IN</sub> Nom. (Volts)	Range (Volts)	I <sub>IN</sub> <sup>④</sup> (mA)		Min.	Typ.
			Typ.	Max.	Line	Load <sup>③</sup>						
<b>Discontinued</b> BST-5/250-D12-C	±5	±250	75	120	±0.5%	±0.5%	12	9-18	25/267	75%	78%	C1,P2
<b>Discontinued</b> BST-5/250-D48-C	±5	±250	75	120	±0.5%	±0.5%	48	18-72	7/69	72%	76%	C1,P2
<b>Discontinued</b> BST-12/125-D12-C	±12	±125	75	150	±0.5%	±0.5%	12	9-18	25/329	74%	76%	C1,P2
<b>Available</b> BST-12/125-D48-C	±12	±125	75	150	±0.5%	±0.5%	48	18-72	8/81	73%	77%	C1,P2
<b>Discontinued</b> BST-15/100-D12-C	±15	±100	75	150	±0.5%	±0.5%	12	9-18	25/329	74%	76%	C1,P2
<b>Available</b> BST-15/100-D48-C	±15	±100	75	150	±0.5%	±0.5%	48	18-72	8/81	73%	77%	C1,P2
<b>Discontinued</b> BST-12/105-D5-C	±12	±105	75	150	±0.5%	±0.5%	5	4.5-9	60/690	71%	73%	C1,P2
<b>Discontinued</b> BST-15/85-D5-C	±15	±85	75	150	±0.5%	±0.5%	5	4.5-9	68/689	72%	74%	C1,P2

- ① Typical at TA = +25°C under nominal line voltage and full-load conditions unless otherwise noted.
- ② Ripple/Noise (R/N) measured over a 20 MHz bandwidth.
- ③ Balanced loads, 10% to 100% load.
- ④ Nominal line voltage, no-load/full-load conditions.

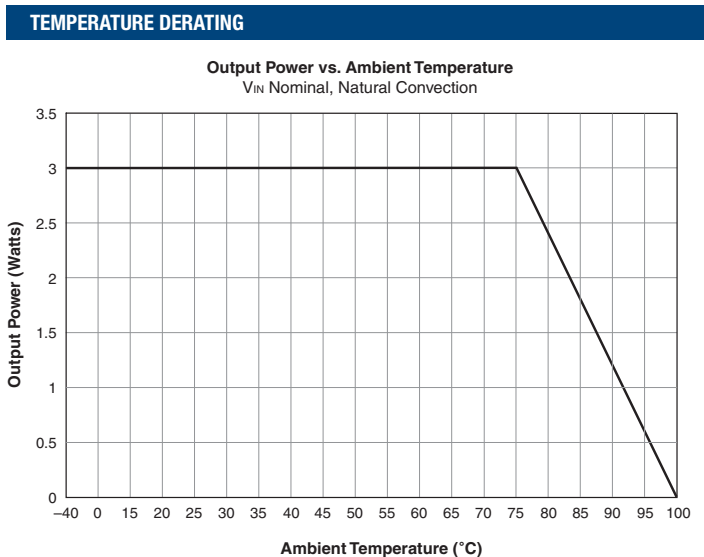
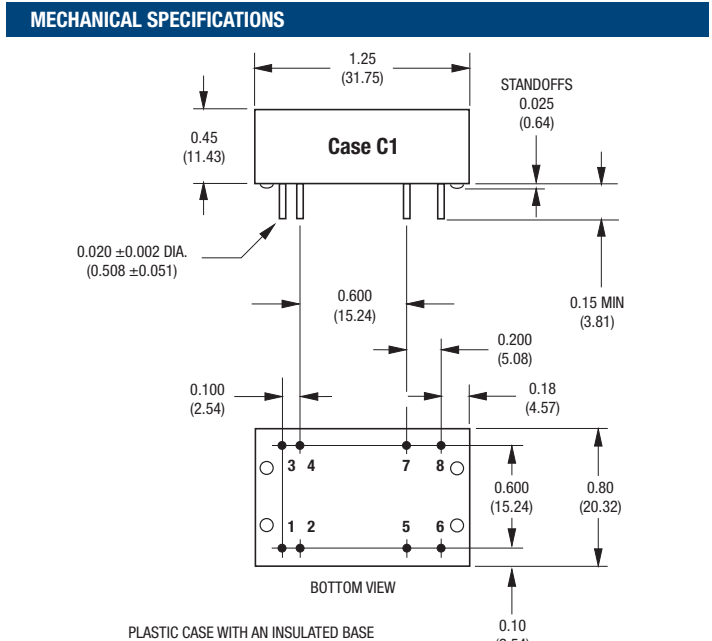
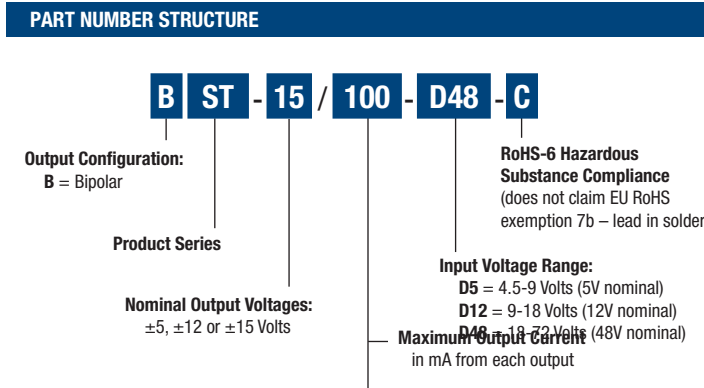

### I/O Connections

Pin	Function P2
1	+Input
2	+Input
3	-Input
4	-Input
5	Common
6	+Output
7	Common
8	-Output

DIMENSIONS ARE IN INCHES (MM)  
Dimensions are in inches (mm shown for ref. only).

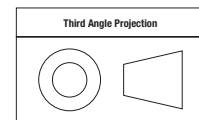

Tolerances (unless otherwise specified):  
.XX ± 0.02 (0.5)  
.XXX ± 0.010 (0.25)  
Angles ± 2°  
Components are shown for reference only.

### Performance/Functional Specifications

Typical @ T<sub>A</sub> = +25°C under nominal line voltage and full-load conditions unless noted. ①

Input	
<b>Input Voltage Range:</b>	
"D5" Models	4.5-9 Volts (5V nominal)
"D12" Models	9-18 Volts (12V nominal)
"D48" Models	18-72 Volts (48V nominal)
<b>Input Current</b>	See Ordering Guide
<b>Input Filter Type</b>	Pi
<b>Reverse-Polarity Protection</b>	Yes (Instantaneous, 2A maximum)
Output	
<b>V<sub>OUT</sub> Accuracy (50% load)</b>	±1%, maximum
<b>Temperature Coefficient</b>	±0.02% per °C
<b>Ripple/Noise (20MHz BW)</b>	See Ordering Guide
<b>Line/Load Regulation</b>	See Ordering Guide
<b>Efficiency</b>	See Ordering Guide
<b>Isolation Voltage</b>	1000Vdc, minimum
<b>Short Circuit Protection:</b> ②	
"D5" Models	Power-limiting technique, auto-recovery
"D12" and "D48" Models	Hiccup technique, auto-recovery
Dynamic Characteristics	
<b>Transient Response (50% load step)</b>	200µsec to ±1.5% of final value
<b>Switching Frequency:</b>	
"D48" Models	200kHz
"D5" and "D12" Models	170kHz
Environmental	
<b>Operating Temperature (Ambient, no derating)</b>	-40 to +75°C
<b>Storage Temperature</b>	-55 to +100°C
Physical	
<b>Dimensions</b>	1.25" x 0.8" x 0.45" (31.8 x 20.3 x 11.4mm)
<b>Case Material</b>	Diallyl phthalate, UL94V-0 rated
<b>Pin Material</b>	Gold-plated copper alloy with nickel underplate
<b>Weight</b>	0.5 ounces (14.2 grams)

① These power converters require a minimum 10% loading to maintain specified regulation. Operation under no-load conditions will not damage these devices; however they may not meet all listed specifications.

② The current limit inception point is dependent on the input voltage. Therefore, it is possible to draw current beyond the rated capacity. Users should fully characterize their load conditions.

### Absolute Maximum Ratings

<b>Input Voltage:</b>	
"D5" Models	12 Volts
"D12" Models	20 Volts
"D48" Models	80 Volts
<b>Input Reverse-Polarity Protection</b>	Current must be <2A. Brief duration only. Fusing recommended.
<b>Output Overvoltage Protection</b>	None
<b>Output Current</b>	Maximum current and short-circuit duration are model dependent. "D12" and "D48" models can withstand sustained output short circuits.
<b>Storage Temperature</b>	-55 to +100°C
<b>Lead Temperature (soldering, 10 sec.)</b>	+280°C

These are stress ratings. Exposure of devices to greater than any of these conditions may adversely affect long-term reliability. Proper operation under conditions other than those listed in the Performance/Functional Specifications Table is not implied or recommended.

### TECHNICAL NOTES

#### Floating Outputs

Since these are isolated DC/DC converters, their outputs are "floating." Any BST model may be configured to produce an output of 10V, 24V or 30V (for ±5V, ±12V or ±15V models, respectively) by applying the load across the +Output (pin 6) and -Output (pin 8), with either output grounded. The Common (pins 5 and 7) should be left open (unconnected). Minimum 20% loading is recommended under these conditions.

#### Filtering and Noise Reduction

All BST 3 Watt DC/DC Converters achieve their rated ripple and noise specifications without the use of external input/output capacitors. In critical applications, input/output ripple and noise may be further reduced by installing electrolytic capacitors across the input terminals and/or low-ESR tantalum or electrolytic capacitors across the output terminals. Output capacitors should be connected between their respective output pin (pins 6 and 8) and Common (pins 5 and 7) as shown in Figure 2. The caps should be located as close to the power converters as possible. Typical values are listed in the tables below. In many applications, using values greater than those listed will yield better results.

#### To Reduce Input Ripple

"D5" Models	47µF, 15V
"D12" Models	10µF, 35V
"D48" Models	4.7µF, 100V

#### To Reduce Output Ripple

±5V Outputs	47µF, 10V, Low ESR
±12/15V Outputs	22µF, 20V, Low ESR

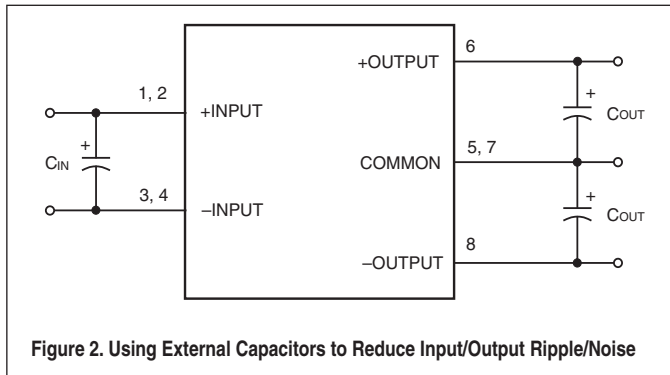

### Custom Capabilities

MPS's world-class design, development and manufacturing team stands ready to work with you to deliver the exact power converter you need for your demanding, large volume, OEM applications. And ... we'll do it on time and within budget!

Our experienced applications and design staffs; quick-turn prototype capability; highly automated, SMT assembly facilities; and in-line SPC quality-control techniques combine to give us the unique ability to design and deliver any quantity of power converters to the highest standards of quality and reliability.

We have compiled a large library of DC/DC designs that are currently used in a variety of telecom, medical, computer, railway, aerospace and industrial applications. We may already have the converter you need.

Contact us. Our goal is to provide you the highest-quality, most cost-effective power converters available.

### Input Fusing

Certain applications and/or safety agencies may require the installation of fuses at the inputs of power conversion components. For MPS's BST 3 Watt DC/DC Converters, you should use fast-blow type fuses with values no greater than the following:

V <sub>IN</sub> Range	Fuse Value
"D5"	1.5A
"D12"	1A
"D48"	0.5A



## Looking for pricing, stock, or lifecycle information?

Click below to explore more details on WIN SOURCE:

- [View BST-15/100-D48-C on WIN SOURCE](#)
- [Murata Power Solutions Inc. Information](#)

## Optimize Your Supply Chain with WIN SOURCE Solutions

- ✓ Global Sourcing Solution
- ✓ Obsolete Management
- ✓ Cost Control Management
- ✓ Shortage Management
- ✓ Alternative Solution
- ✓ Excess Inventory Management