



**THE DATASHEET OF  
CER0391A**



### Features

- Low loss
- Flat Low Ripple
- High Rejection

### Description

Surface mount, silver (Ag) coated ceramic duplexer. Developed for use in DCS infrastructure applications.

Weight: 3.0 grams typical

Material: Filter is composed of a ceramic block plated with Ag and a shield made of nickel silver plated steel.

Filter complies with RoHS standards.



### Electrical Specifications

Parameter	Frequency MHz	Typical @ 25°C	Specification @ 25°C	Spec over -40°C to +85°C
<b>Low Band Response (S21)</b>				
Passband Iloss	1850 - 1880	-1.50	-1.80	-2.00
Passband Ripple	1850 - 1880	0.60	1.00	1.10
Passband Return Loss @ Port 2	1850 - 1880	-14.00	-12.00	-12.00
Passband Return Loss @ Ant	1850 - 1880	-14.00	-12.00	-12.00
Attenuation	1755 - 1785	-57.00	-55.00	-55.00
<b>High Band Response (S13)</b>				
Passband Iloss	1755 - 1785	-1.00	-1.80	-2.00
Passband Ripple	1755 - 1785	0.30	0.70	0.80
Passband Return Loss @ Port 3	1755 - 1785	-14.00	-12.00	-12.00
Passband Return Loss @ Ant	1755 - 1785	-14.00	-12.00	-12.00
Attenuation	1850 - 1880	-58.00	-55.00	-55.00
<b>Isolation (S23)</b>				
Rejection @ Low Band	1755 - 1785	-59.00	-55.00	-55.00
Rejection @ High Band	1850 - 1880	-58.00	-55.00	-55.00
Power into any port		3 Watt max		

Note: Supplier shall test each filter to the critical electrical specifications of the above table. Any subsequent audits may deviate from in value due to measurement repeatability among different test systems. Such deviations shall not exceed the following limits:

Specification Allowance	
Insertion Loss	0.1 dB
Return Loss	1.0 dB
Stopbands	1.0 dB

\*This product is covered by one or more of the following U.S. and foreign patents including: US 4,692,726;US 4,742,562; US 4,800,348;US 4,829,274;US 5,146,193;EP 0573597;DE 0573597;FR 0573597;JP 508149/92;KR 142171;US 5,162,760;US 5,218,329;US 5,250,916;US 5,327,109;US 5,488,335;CA 2114029;FR 9306297;GB 2273393;JP 3205337;KR 115113;CN 93106228.4;US 5,512,866;EP 0706719;DE 0706719;FR 0706719;GB 0706719;CN 95190359.4;US 5,602,518;US 5,721,520;US 5,745,018;EP 0910875;DE 0910875;DK 0910875;FR 0910875;GB 0910875;IE 0910875;JP 505182/98;KR 10-323013;US 5,994,978;US 6,462,629;CN 00810420.4;US 6,559,735;US 6,650,202;US 6,834,429. Other US and foreign patents pending.

\*CTS Corporation 2006 reserves all copyrights in the layout, design and configuration of the patterns on this product.\*

### Mechanical Drawing

Rev 1 – Origin Date: April 11, 2006 – Revision Date: April 17, 2006

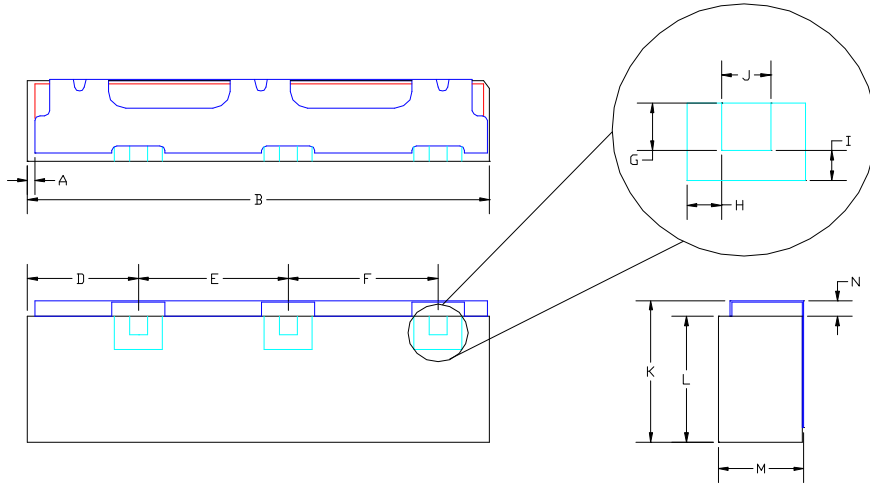

Dim	Nominal (mm)	Tolerance (mm) +/- or max
A	0.25	0.25
B	24.04	max
C		
D	2.72	0.25
E	7.44	0.13
F	10.52	0.13
G	1.02	0.13
H	0.79	0.13
I	0.79	0.13
J	0.89	0.13
K	7.20	max
L	6.10	max
M	4.60	max
N	0.84	0.13

### Electrical response

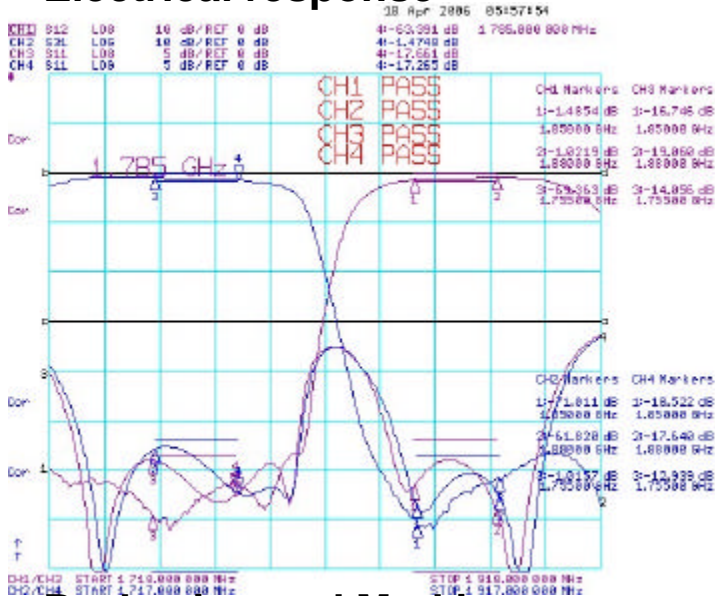

### PCB Layout

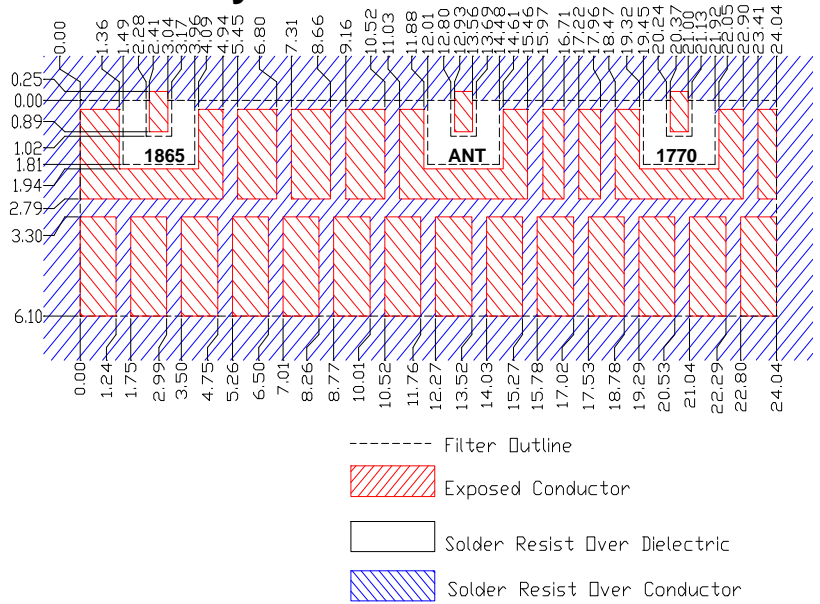

### Packaging and Marking

DIMENSION	UNITS	SPECIFICATION
REEL DIAMETER	mm	330
REEL WEIGHT	kg	2.3 max
REEL QUANTITY	ea.	500

CUSTOMER FEED DIRECTION

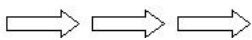

#### Product Marking

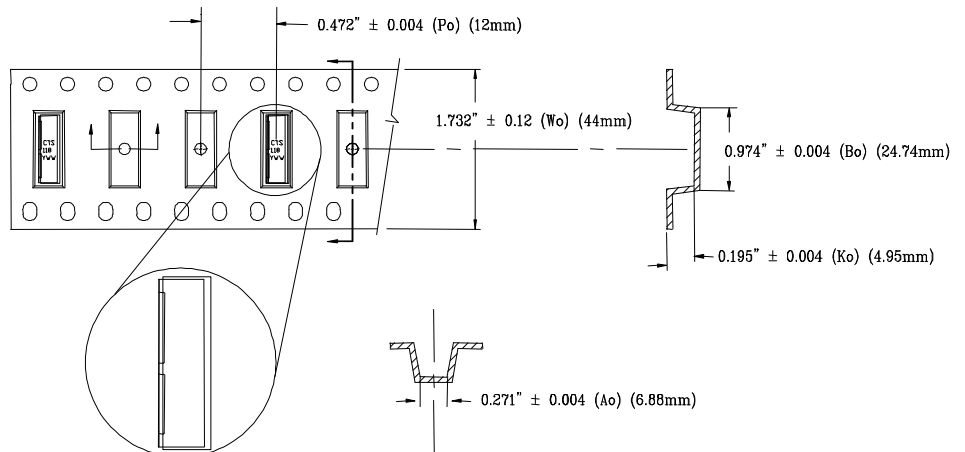
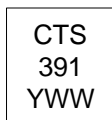

## Looking for pricing, stock, or lifecycle information?

Click below to explore more details on WIN SOURCE:

- ⊖ [View CER0391A on WIN SOURCE](#)
- ⊖ [Tusonix a Subsidiary of CTS Electronic Components Information](#)

## Optimize Your Supply Chain with WIN SOURCE Solutions

- ✓ Global Sourcing Solution
- ✓ Obsolete Management
- ✓ Cost Control Management
- ✓ Shortage Management
- ✓ Alternative Solution
- ✓ Excess Inventory Management