



**THE DATASHEET OF  
CS2841BED14**



# CS2841B

## Automotive Current Mode PWM Control Circuit

The CS2841B provides all the necessary features to implement off-line fixed frequency current-mode control with a minimum number of external components.

The CS2841B (a variation of the CS2843A) is designed specifically for use in automotive operation. The low start threshold voltage of 8.0 V (typ), and the ability to survive 40 V automotive load dump transients are important for automotive subsystem designs. The CS2841 series has a history of quality and reliability in automotive applications.

The CS2841B incorporates a precision temperature-controlled oscillator with an internally trimmed discharge current to minimize variations in frequency. Duty-cycles greater than 50% are also possible. On board logic ensures that  $V_{REF}$  is stabilized before the output stage is enabled. Ion implant resistors provide tighter control of undervoltage lockout.

### Features

- Optimized for Off-Line Control
- Internally Trimmed Temperature Compensated Oscillator
- Maximum Duty-Cycle Clamp
- $V_{REF}$  Stabilized Before Output Stage Enabled
- Low Start-Up Current
- Pulse-By-Pulse Current Limiting
- Improved Undervoltage Lockout
- Double Pulse Suppression
- 1.0 % Trimmed Bandgap Reference
- High Current Totem Pole Output
- Pb-Free Packages are Available\*



ON Semiconductor®

<http://onsemi.com>

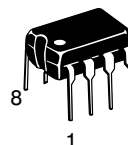

PDP-8  
N SUFFIX  
CASE 626

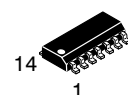

SOIC-14  
D SUFFIX  
CASE 751A

### PIN CONNECTIONS AND MARKING DIAGRAM

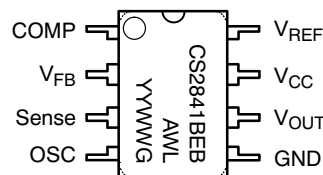

PDP-8

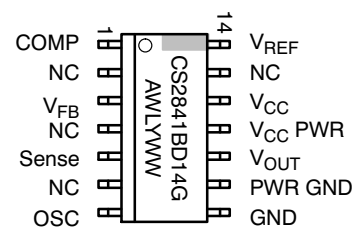

SOIC-14

CS2841B = Device Code  
A = Assembly Location  
WL = Wafer Lot  
YY, Y = Year  
WW = Work Week  
G = Pb-Free Package

\*For additional information on our Pb-Free strategy and soldering details, please download the ON Semiconductor Soldering and Mounting Techniques Reference Manual, SOLDERRM/D.

### ORDERING INFORMATION

See detailed ordering and shipping information in the package dimensions section on page 2 of this data sheet.

# CS2841B

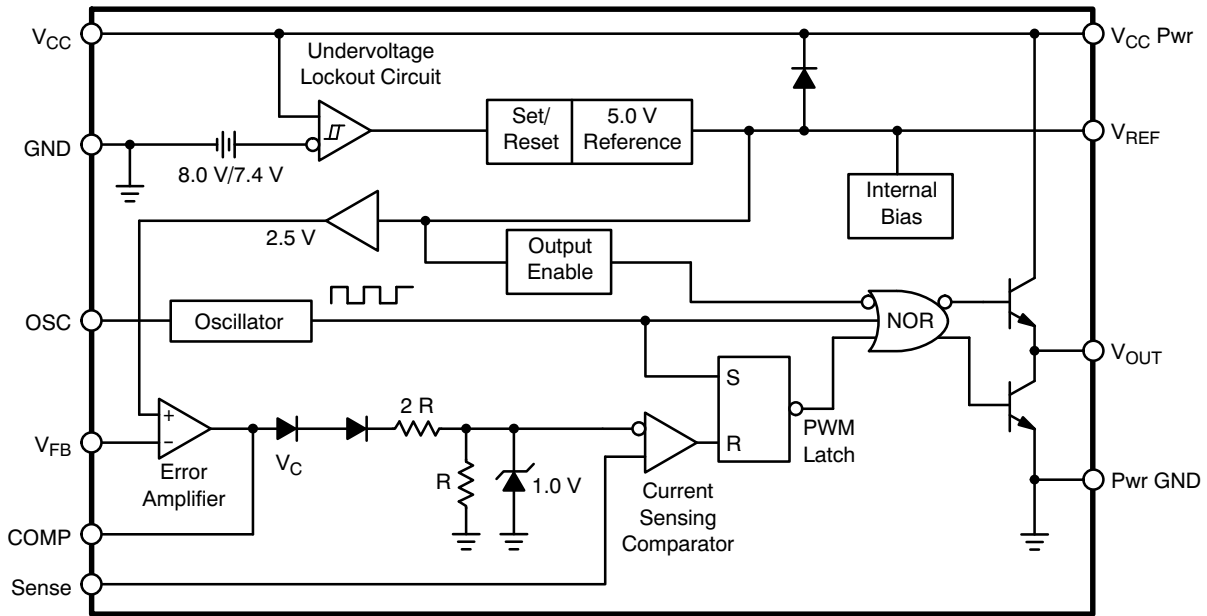

Figure 1. Block Diagram

## MAXIMUM RATINGS

Rating	Value	Unit	
Supply Voltage (Low Impedance Source)	40	V	
Output Current	±1.0	A	
Output Energy (Capacitive Load)	5.0	μJ	
Analog Inputs (V <sub>FB</sub> , Sense)	-0.3 to 5.5	V	
Error Amp Output Sink Current	10	mA	
Lead Temperature Soldering	Wave Solder (through hole styles only) Note 1 Reflow (SMD styles only) Note 2	260 peak 230 peak	°C °C

Stresses exceeding Maximum Ratings may damage the device. Maximum Ratings are stress ratings only. Functional operation above the Recommended Operating Conditions is not implied. Extended exposure to stresses above the Recommended Operating Conditions may affect device reliability.

1. 10 seconds max
2. 60 seconds max above 183°C

## ORDERING INFORMATION

Device	Package	Shipping <sup>†</sup>
CS2841BEBN8	PDIP-8	50 Units / Rail
CS2841BEBN8G	PDIP-8 (Pb-Free)	50 Units / Rail
CS2841BED14	SOIC-14	55 Units / Rail
CS2841BED14G	SOIC-14 (Pb-Free)	55 Units / Rail
CS2841BEDR14	SOIC-14	2500 / Tape & Reel
CS2841BEDR14G	SOIC-14 (Pb-Free)	2500 / Tape & Reel

<sup>†</sup>For information on tape and reel specifications, including part orientation and tape sizes, please refer to our Tape and Reel Packaging Specifications Brochure, BRD8011/D.

# CS2841B

**ELECTRICAL CHARACTERISTICS** ( $-40^{\circ}\text{C} \leq T_A \leq 85^{\circ}\text{C}$ ,  $R_T = 680\text{ k}\Omega$ ,  $C_T = 0.022\text{ }\mu\text{F}$  for Triangular Mode,  $V_{CC} = 15\text{ V}$  (Note 3),  $R_T = 10\text{ k}\Omega$ ,  $C_T = 3.3\text{ nF}$  for Sawtooth Mode (see Figure 7); unless otherwise specified.)

Characteristic	Test Conditions	Min	Typ	Max	Unit
----------------	-----------------	-----	-----	-----	------

## Reference Section

Output Voltage	$T_J = 25^{\circ}\text{C}$ , $I_{OUT} = 1.0\text{ mA}$	4.9	5.0	5.1	V
Line Regulation	$8.4 \leq V_{CC} \leq 16\text{ V}$	-	6.0	20	mV
Load Regulation	$1.0 \leq I_{OUT} \leq 20\text{ mA}$	-	6.0	25	mV
Temperature Stability	Note 4	-	0.2	0.4	mV/ $^{\circ}\text{C}$
Total Output Variation	Line, Load, Temp. Note 4	4.82	-	5.18	V
Output Noise Voltage	$10\text{ Hz} \leq f \leq 10\text{ kHz}$ , $T_J = 25^{\circ}\text{C}$ . Note 4	-	50	-	$\mu\text{V}$
Long Term Stability	$T_A = 125^{\circ}\text{C}$ , 1000 Hrs. Note 4	-	5.0	25	mV
Output Short Circuit	$T_A = 25^{\circ}\text{C}$	-30	-100	-180	mA

## Oscillator Section

Initial Accuracy	Sawtooth Mode: $T_J = 25^{\circ}\text{C}$ . See Figure 7.	47	52	57	kHz
	Sawtooth Mode: $-40^{\circ}\text{C} \leq T_A \leq +85^{\circ}\text{C}$	44	52	60	kHz
	Triangular Mode: $T_J = 25^{\circ}\text{C}$ . See Figure 7.	44	52	60	kHz
Voltage Stability	$8.4 \leq V_{CC} \leq 16\text{ V}$	-	0.2	1.0	%
Temperature Stability	Sawtooth Mode: $T_{MIN} \leq T_A \leq T_{MAX}$ . Note 4	-	5.0	-	%
	Triangular Mode: $T_{MIN} \leq T_A \leq T_{MAX}$ . Note 4	-	8.0	-	%
Amplitude	$V_{OSC}$ (Peak to Peak)	-	1.7	-	V
Discharge Current	$T_J = 25^{\circ}\text{C}$	7.4	8.3	9.2	mA
	$T_{MIN} \leq T_A \leq T_{MAX}$	7.2	-	9.4	mA

## Error Amp Section

Input Voltage	$V_{COMP} = 2.5\text{ V}$	2.42	2.5	2.58	V
Input Bias Current	$V_{FB} = 0\text{ V}$	-	-0.3	-2.0	$\mu\text{A}$
$A_{VOL}$	$2.0 \leq V_{OUT} \leq 4.0\text{ V}$	65	90	-	dB
Unity Gain Bandwidth	Note 4	0.7	1.0	-	MHz
PSRR	$8.4\text{ V} \leq V_{CC} \leq 16\text{ V}$	60	70	-	dB
Output Sink Current	$V_{FB} = 2.7\text{ V}$ , $V_{COMP} = 1.1\text{ V}$	2.0	6.0	-	mA
Output Source Current	$V_{FB} = 2.3\text{ V}$ , $V_{COMP} = 5.0\text{ V}$	-0.5	-0.8	-	mA
$V_{OUT}$ High	$V_{FB} = 2.3\text{ V}$ , $R_L = 15\text{ k}\Omega$ to Ground	5.0	6.0	-	V
$V_{OUT}$ Low	$V_{FB} = 2.7\text{ V}$ , $R_L = 15\text{ k}\Omega$ to $V_{REF}$	-	0.7	1.1	V

## Current Sense Section

Gain	Notes 5 and 6	2.85	3.0	3.15	V/V
Maximum Input Signal	$V_{COMP} = 5.0\text{ V}$ . Note 5	0.9	1.0	1.1	V
PSRR	$12\text{ V} \leq V_{CC} \leq 25\text{ V}$ . Note 5	-	70	-	dB
Input Bias Current	$V_{Sense} = 0\text{ V}$	-	-2.0	-10	$\mu\text{A}$
Delay to Output	$T_J = 25^{\circ}\text{C}$ . Note 4	-	150	300	ns

- Adjust  $V_{CC}$  above the start threshold before setting at 15 V
- These parameters, although guaranteed, are not 100% tested in production
- Parameter measured at trip point of latch with  $V_{FB} = 0$
- Gain defined as:

$$A = \frac{\Delta V_{COMP}}{\Delta V_{Sense}}; 0 \leq V_{Sense} \leq 0.8\text{ V}.$$

# CS2841B

**ELECTRICAL CHARACTERISTICS** ( $-40^{\circ}\text{C} \leq T_A \leq 85^{\circ}\text{C}$ ,  $R_T = 680\text{ k}\Omega$ ,  $C_T = 0.022\text{ }\mu\text{F}$  for Triangular Mode,  $V_{CC} = 15\text{ V}$  (Note 3),  $R_T = 10\text{ k}\Omega$ ,  $C_T = 3.3\text{ nF}$  for Sawtooth Mode (see Figure 7); unless otherwise specified.)

Characteristic	Test Conditions	Min	Typ	Max	Unit
----------------	-----------------	-----	-----	-----	------

## Output Section

Output Low Level	$I_{\text{SINK}} = 20\text{ mA}$	-	0.1	0.4	V
	$I_{\text{SINK}} = 200\text{ mA}$	-	1.5	2.2	V
Output High Level	$I_{\text{SOURCE}} = 20\text{ mA}$	13	13.5	-	V
	$I_{\text{SOURCE}} = 200\text{ mA}$	12	13.5	-	V
Rise Time	$T_J = 25^{\circ}\text{C}$ , $C_L = 1.0\text{ nF}$ . Note 7	-	50	150	ns
Fall Time	$T_J = 25^{\circ}\text{C}$ , $C_L = 1.0\text{ nF}$ . Note 7	-	50	150	ns
Output Leakage	Undervoltage Active, $V_{\text{OUT}} = 0$	-	-0.01	-10	$\mu\text{A}$

## Total Standby Current

Startup Current	-	-	0.5	1.0	mA
Operating Supply Current $I_{\text{CC}}$	$V_{\text{FB}} = V_{\text{Sense}} = 0\text{ V}$ , $R_T = 10\text{ k}\Omega$ , $C_T = 3.3\text{ nF}$	-	11	17	mA

## Undervoltage Lockout Section

Start Threshold	-	7.6	8.0	8.4	V
Min. Operating Voltage	After Turn On	7.0	7.4	7.8	V

7. These parameters, although guaranteed, are not 100% tested in production.

## PACKAGE PIN DESCRIPTION

PACKAGE PIN #		PIN SYMBOL	FUNCTION
PDIP-8	SOIC-14		
1	1	COMP	Error Amp Output, Used to Compensate Error Amplifier
2	3	$V_{\text{FB}}$	Error Amp Inverting Input
3	5	Sense	Noninverting Input to Current Sense Comparator
4	7	OSC	Oscillator Timing Network with Capacitor to Ground, Resistor to $V_{\text{REF}}$
5	8	GND	Ground
	9	Pwr GND	Output Driver Ground
6	10	$V_{\text{OUT}}$	Output Drive Pin
	11	$V_{\text{CC Pwr}}$	Output Driver Positive Supply
7	12	$V_{\text{CC}}$	Positive Power Supply
8	14	$V_{\text{REF}}$	Output of 5.0 V Internal Reference
	2, 4, 6, 13	NC	No Connection

# CS2841B

## TYPICAL PERFORMANCE CHARACTERISTICS

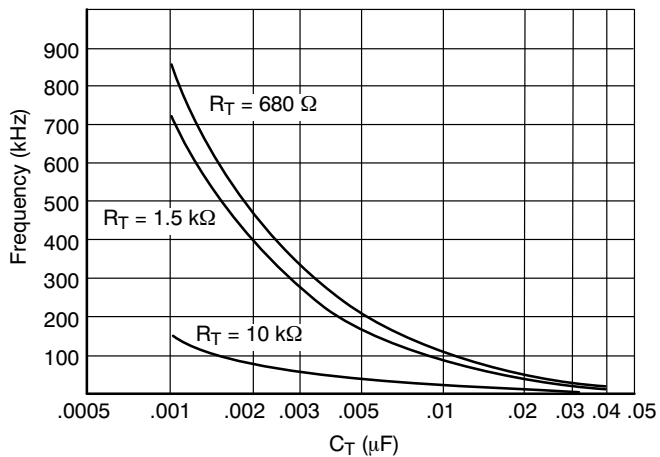

Figure 2. Oscillator Frequency vs.  $C_T$

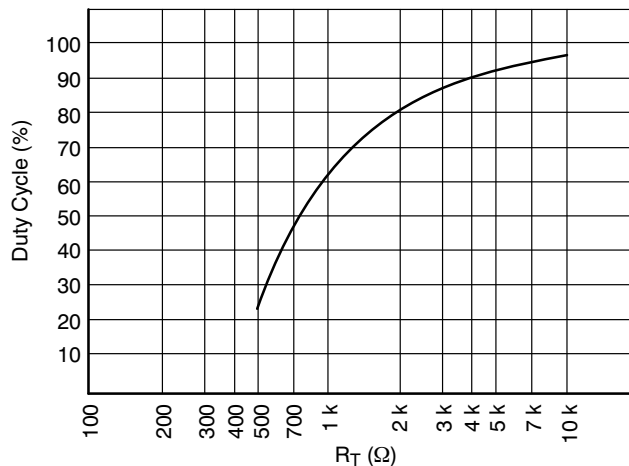

Figure 3. Oscillator Duty Cycle vs.  $R_T$

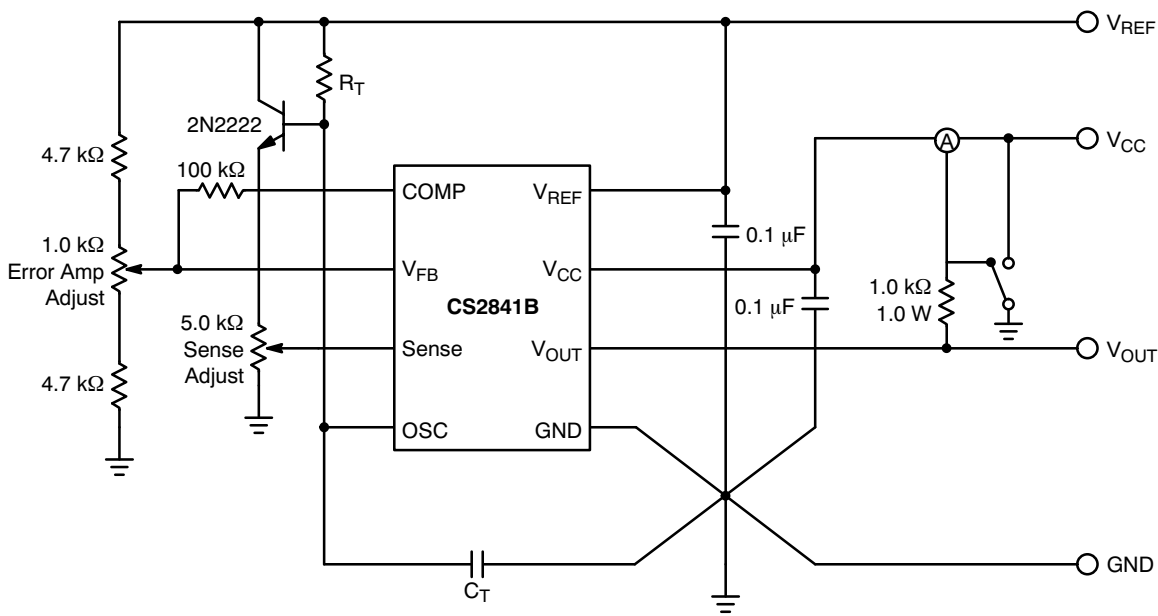

Figure 4. Test Circuit

CIRCUIT DESCRIPTION

**Undervoltage Lockout**

During Undervoltage Lockout (Figure 5), the output driver is biased to a high impedance state. The output should be shunted to ground with a resistor to prevent output leakage current from activating the power switch.

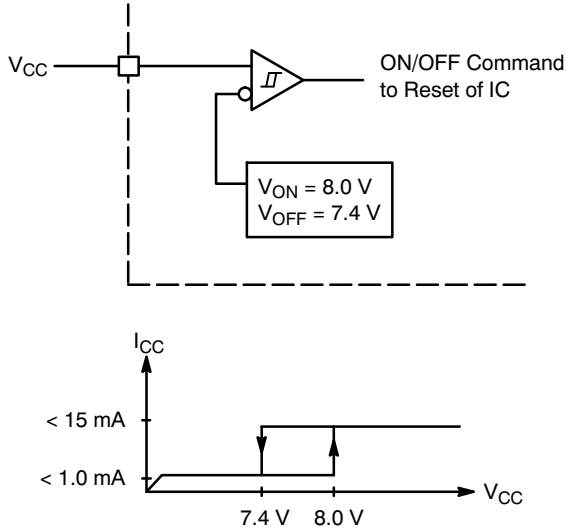

Figure 5. Typical Undervoltage Characteristics

**PWM Waveform**

To generate the PWM waveform, the control voltage from the error amplifier is compared to a current sense signal representing the peak output inductor current (Figure 6). An increase in  $V_{CC}$  causes the inductor current slope to increase, thus reducing the duty cycle. This is an inherent feed-forward characteristic of current mode control, since the control voltage does not have to change during changes of input supply voltage.

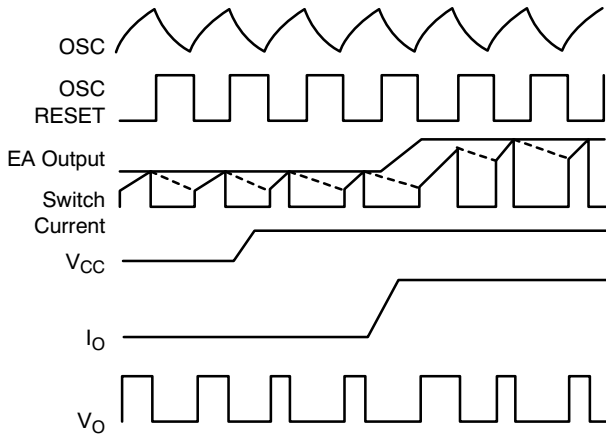
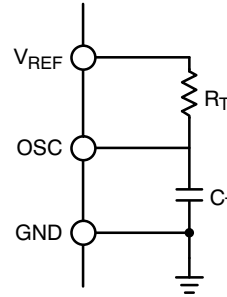
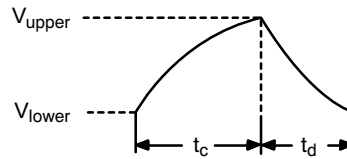

Figure 6. Timing Diagram for Key CS2841B Parameters

When the power supply sees a sudden large output current increase, the control voltage will increase allowing the duty cycle to momentarily increase. Since the duty cycle tends to exceed the maximum allowed to prevent transformer saturation in some power supplies, the internal oscillator waveform provides the maximum duty cycle clamp as programmed by the selection of OSC components.



**Timing Parameters**



**Sawtooth Mode**

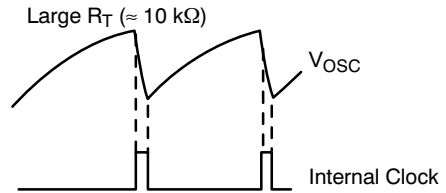

**Triangular Mode**

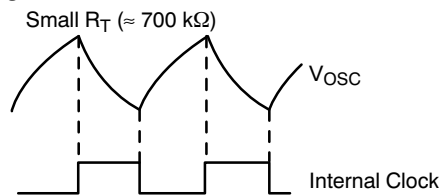

Figure 7. Oscillator Timing Network and Parameters

**Setting the Oscillator**

Oscillator timing capacitor,  $C_T$ , is charged by  $V_{REF}$  through  $R_T$  and discharged by an internal current source. During the discharge time, the internal clock signal blanks out the output to the Low state, thus providing a user selected maximum duty cycle clamp. Charge and discharge times are determined by the general formulas:



# CS2841B

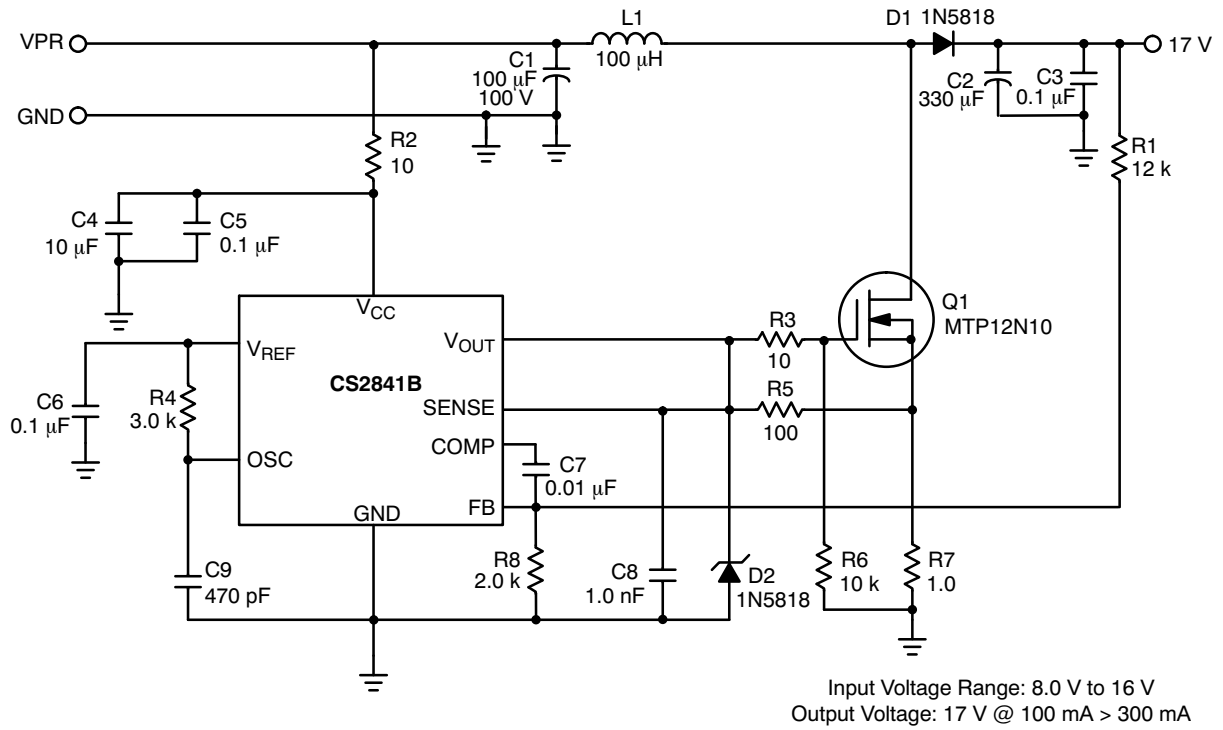

Figure 9. Boost Application

## PACKAGE THERMAL DATA

Parameter		PDIP-8	SOIC-14	Unit
$R_{\theta JC}$	Typical	52	30	$^{\circ}\text{C}/\text{W}$
$R_{\theta JA}$	Typical	100	125	$^{\circ}\text{C}/\text{W}$

# MECHANICAL CASE OUTLINE PACKAGE DIMENSIONS

ON Semiconductor®



SCALE 1:1

PDIP-8  
CASE 626-05  
ISSUE P

DATE 22 APR 2015

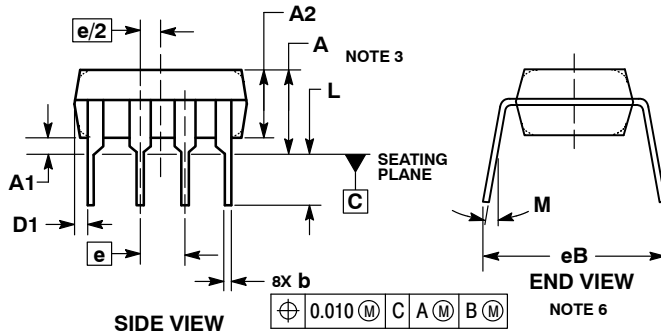
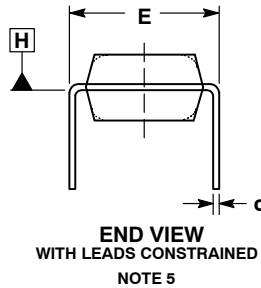
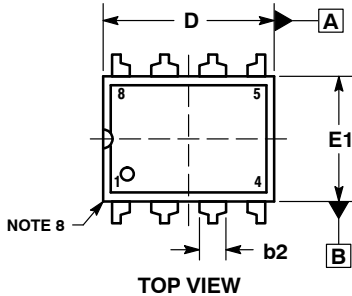

NOTES:

1. DIMENSIONING AND TOLERANCING PER ASME Y14.5M, 1994.
2. CONTROLLING DIMENSION: INCHES.
3. DIMENSIONS A, A1 AND L ARE MEASURED WITH THE PACKAGE SEATED IN JEDEC SEATING PLANE GAUGE GS-3.
4. DIMENSIONS D, D1 AND E1 DO NOT INCLUDE MOLD FLASH OR PROTRUSIONS. MOLD FLASH OR PROTRUSIONS ARE NOT TO EXCEED 0.10 INCH.
5. DIMENSION E IS MEASURED AT A POINT 0.015 BELOW DATUM PLANE H WITH THE LEADS CONSTRAINED PERPENDICULAR TO DATUM C.
6. DIMENSION eB IS MEASURED AT THE LEAD TIPS WITH THE LEADS UNCONSTRAINED.
7. DATUM PLANE H IS COINCIDENT WITH THE BOTTOM OF THE LEADS, WHERE THE LEADS EXIT THE BODY.
8. PACKAGE CONTOUR IS OPTIONAL (ROUNDED OR SQUARE CORNERS).

DIM	INCHES		MILLIMETERS	
	MIN	MAX	MIN	MAX
A	----	0.210	----	5.33
A1	0.015	----	0.38	----
A2	0.115	0.195	2.92	4.95
b	0.014	0.022	0.35	0.56
b2	0.060 TYP		1.52 TYP	
C	0.008	0.014	0.20	0.36
D	0.355	0.400	9.02	10.16
D1	0.005	----	0.13	----
E	0.300	0.325	7.62	8.26
E1	0.240	0.280	6.10	7.11
e	0.100 BSC		2.54 BSC	
eB	----	0.430	----	10.92
L	0.115	0.150	2.92	3.81
M	----	10°	----	10°

GENERIC  
MARKING DIAGRAM\*

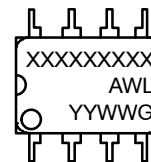

- XXXX = Specific Device Code
- A = Assembly Location
- WL = Wafer Lot
- YY = Year
- WW = Work Week
- G = Pb-Free Package

\*This information is generic. Please refer to device data sheet for actual part marking. Pb-Free indicator, "G" or microdot "▪", may or may not be present.

- STYLE 1:  
PIN 1. AC IN  
2. DC + IN  
3. DC - IN  
4. AC IN  
5. GROUND  
6. OUTPUT  
7. AUXILIARY  
8. V<sub>CC</sub>

DOCUMENT NUMBER:	98ASB42420B	Electronic versions are uncontrolled except when accessed directly from the Document Repository. Printed versions are uncontrolled except when stamped "CONTROLLED COPY" in red.
DESCRIPTION:	PDIP-8	PAGE 1 OF 1

ON Semiconductor and are trademarks of Semiconductor Components Industries, LLC dba ON Semiconductor or its subsidiaries in the United States and/or other countries. ON Semiconductor reserves the right to make changes without further notice to any products herein. ON Semiconductor makes no warranty, representation or guarantee regarding the suitability of its products for any particular purpose, nor does ON Semiconductor assume any liability arising out of the application or use of any product or circuit, and specifically disclaims any and all liability, including without limitation special, consequential or incidental damages. ON Semiconductor does not convey any license under its patent rights nor the rights of others.

# MECHANICAL CASE OUTLINE PACKAGE DIMENSIONS

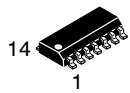

SCALE 1:1

SOIC-14 NB  
CASE 751A-03  
ISSUE L

DATE 03 FEB 2016

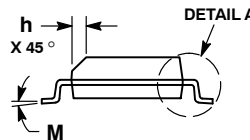
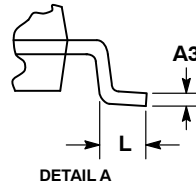

NOTES:

1. DIMENSIONING AND TOLERANCING PER ASME Y14.5M, 1994.
2. CONTROLLING DIMENSION: MILLIMETERS.
3. DIMENSION b DOES NOT INCLUDE DAMBAR PROTRUSION. ALLOWABLE PROTRUSION SHALL BE 0.13 TOTAL IN EXCESS OF AT MAXIMUM MATERIAL CONDITION.
4. DIMENSIONS D AND E DO NOT INCLUDE MOLD PROTRUSIONS.
5. MAXIMUM MOLD PROTRUSION 0.15 PER SIDE.

DIM	MILLIMETERS		INCHES	
	MIN	MAX	MIN	MAX
A	1.35	1.75	0.054	0.068
A1	0.10	0.25	0.004	0.010
A3	0.19	0.25	0.008	0.010
b	0.35	0.49	0.014	0.019
D	8.55	8.75	0.337	0.344
E	3.80	4.00	0.150	0.157
e	1.27 BSC		0.050 BSC	
H	5.80	6.20	0.228	0.244
h	0.25	0.50	0.010	0.019
L	0.40	1.25	0.016	0.049
M	0°	7°	0°	7°

SOLDERING FOOTPRINT\*

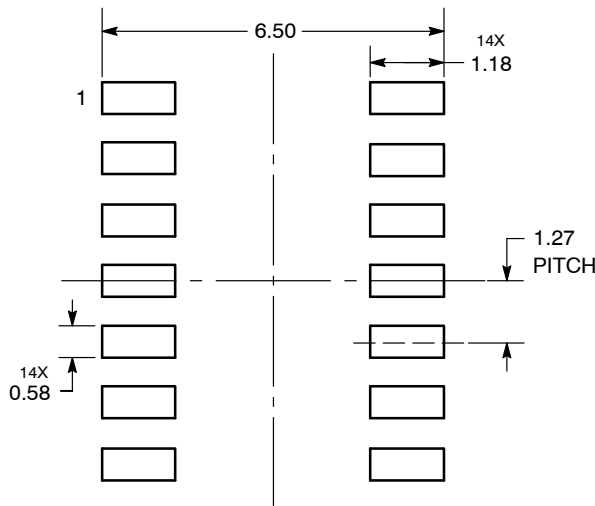

DIMENSIONS: MILLIMETERS

\*For additional information on our Pb-Free strategy and soldering details, please download the ON Semiconductor Soldering and Mounting Techniques Reference Manual, SOLDERRM/D.

GENERIC MARKING DIAGRAM\*

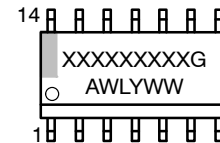

- XXXXXX = Specific Device Code
- A = Assembly Location
- WL = Wafer Lot
- Y = Year
- WW = Work Week
- G = Pb-Free Package

\*This information is generic. Please refer to device data sheet for actual part marking. Pb-Free indicator, "G" or microdot "▪", may or may not be present. Some products may not follow the Generic Marking.

STYLES ON PAGE 2

DOCUMENT NUMBER:	98ASB42565B	Electronic versions are uncontrolled except when accessed directly from the Document Repository. Printed versions are uncontrolled except when stamped "CONTROLLED COPY" in red.
DESCRIPTION:	SOIC-14 NB	PAGE 1 OF 2

onsemi and onsemi are trademarks of Semiconductor Components Industries, LLC dba onsemi or its subsidiaries in the United States and/or other countries. onsemi reserves the right to make changes without further notice to any products herein. onsemi makes no warranty, representation or guarantee regarding the suitability of its products for any particular purpose, nor does onsemi assume any liability arising out of the application or use of any product or circuit, and specifically disclaims any and all liability, including without limitation special, consequential or incidental damages. onsemi does not convey any license under its patent rights nor the rights of others.

**SOIC-14**  
**CASE 751A-03**  
**ISSUE L**

DATE 03 FEB 2016

STYLE 1:  
 PIN 1. COMMON CATHODE  
 2. ANODE/CATHODE  
 3. ANODE/CATHODE  
 4. NO CONNECTION  
 5. ANODE/CATHODE  
 6. NO CONNECTION  
 7. ANODE/CATHODE  
 8. ANODE/CATHODE  
 9. ANODE/CATHODE  
 10. NO CONNECTION  
 11. ANODE/CATHODE  
 12. ANODE/CATHODE  
 13. NO CONNECTION  
 14. COMMON ANODE

STYLE 2:  
 CANCELLED

STYLE 3:  
 PIN 1. NO CONNECTION  
 2. ANODE  
 3. ANODE  
 4. NO CONNECTION  
 5. ANODE  
 6. NO CONNECTION  
 7. ANODE  
 8. ANODE  
 9. ANODE  
 10. NO CONNECTION  
 11. ANODE  
 12. ANODE  
 13. NO CONNECTION  
 14. COMMON CATHODE

STYLE 4:  
 PIN 1. NO CONNECTION  
 2. CATHODE  
 3. CATHODE  
 4. NO CONNECTION  
 5. CATHODE  
 6. NO CONNECTION  
 7. CATHODE  
 8. CATHODE  
 9. CATHODE  
 10. NO CONNECTION  
 11. CATHODE  
 12. CATHODE  
 13. NO CONNECTION  
 14. COMMON ANODE

STYLE 5:  
 PIN 1. COMMON CATHODE  
 2. ANODE/CATHODE  
 3. ANODE/CATHODE  
 4. ANODE/CATHODE  
 5. ANODE/CATHODE  
 6. NO CONNECTION  
 7. COMMON ANODE  
 8. COMMON CATHODE  
 9. ANODE/CATHODE  
 10. ANODE/CATHODE  
 11. ANODE/CATHODE  
 12. ANODE/CATHODE  
 13. NO CONNECTION  
 14. COMMON ANODE

STYLE 6:  
 PIN 1. CATHODE  
 2. CATHODE  
 3. CATHODE  
 4. CATHODE  
 5. CATHODE  
 6. CATHODE  
 7. CATHODE  
 8. ANODE  
 9. ANODE  
 10. ANODE  
 11. ANODE  
 12. ANODE  
 13. ANODE  
 14. ANODE

STYLE 7:  
 PIN 1. ANODE/CATHODE  
 2. COMMON ANODE  
 3. COMMON CATHODE  
 4. ANODE/CATHODE  
 5. ANODE/CATHODE  
 6. ANODE/CATHODE  
 7. ANODE/CATHODE  
 8. ANODE/CATHODE  
 9. ANODE/CATHODE  
 10. ANODE/CATHODE  
 11. COMMON CATHODE  
 12. COMMON ANODE  
 13. ANODE/CATHODE  
 14. ANODE/CATHODE

STYLE 8:  
 PIN 1. COMMON CATHODE  
 2. ANODE/CATHODE  
 3. ANODE/CATHODE  
 4. NO CONNECTION  
 5. ANODE/CATHODE  
 6. ANODE/CATHODE  
 7. COMMON ANODE  
 8. COMMON ANODE  
 9. ANODE/CATHODE  
 10. ANODE/CATHODE  
 11. NO CONNECTION  
 12. ANODE/CATHODE  
 13. ANODE/CATHODE  
 14. COMMON CATHODE

<b>DOCUMENT NUMBER:</b>	<b>98ASB42565B</b>	Electronic versions are uncontrolled except when accessed directly from the Document Repository. Printed versions are uncontrolled except when stamped "CONTROLLED COPY" in red.
<b>DESCRIPTION:</b>	<b>SOIC-14 NB</b>	<b>PAGE 2 OF 2</b>

**onsemi** and **ONSEMI** are trademarks of Semiconductor Components Industries, LLC dba **onsemi** or its subsidiaries in the United States and/or other countries. **onsemi** reserves the right to make changes without further notice to any products herein. **onsemi** makes no warranty, representation or guarantee regarding the suitability of its products for any particular purpose, nor does **onsemi** assume any liability arising out of the application or use of any product or circuit, and specifically disclaims any and all liability, including without limitation special, consequential or incidental damages. **onsemi** does not convey any license under its patent rights nor the rights of others.

**onsemi**, **Onsemi**, and other names, marks, and brands are registered and/or common law trademarks of Semiconductor Components Industries, LLC dba "**onsemi**" or its affiliates and/or subsidiaries in the United States and/or other countries. **onsemi** owns the rights to a number of patents, trademarks, copyrights, trade secrets, and other intellectual property. A listing of **onsemi**'s product/patent coverage may be accessed at [www.onsemi.com/site/pdf/Patent-Marking.pdf](http://www.onsemi.com/site/pdf/Patent-Marking.pdf). **onsemi** reserves the right to make changes at any time to any products or information herein, without notice. The information herein is provided "as-is" and **onsemi** makes no warranty, representation or guarantee regarding the accuracy of the information, product features, availability, functionality, or suitability of its products for any particular purpose, nor does **onsemi** assume any liability arising out of the application or use of any product or circuit, and specifically disclaims any and all liability, including without limitation special, consequential or incidental damages. Buyer is responsible for its products and applications using **onsemi** products, including compliance with all laws, regulations and safety requirements or standards, regardless of any support or applications information provided by **onsemi**. "Typical" parameters which may be provided in **onsemi** data sheets and/or specifications can and do vary in different applications and actual performance may vary over time. All operating parameters, including "Typicals" must be validated for each customer application by customer's technical experts. **onsemi** does not convey any license under any of its intellectual property rights nor the rights of others. **onsemi** products are not designed, intended, or authorized for use as a critical component in life support systems or any FDA Class 3 medical devices or medical devices with a same or similar classification in a foreign jurisdiction or any devices intended for implantation in the human body. Should Buyer purchase or use **onsemi** products for any such unintended or unauthorized application, Buyer shall indemnify and hold **onsemi** and its officers, employees, subsidiaries, affiliates, and distributors harmless against all claims, costs, damages, and expenses, and reasonable attorney fees arising out of, directly or indirectly, any claim of personal injury or death associated with such unintended or unauthorized use, even if such claim alleges that **onsemi** was negligent regarding the design or manufacture of the part. **onsemi** is an Equal Opportunity/Affirmative Action Employer. This literature is subject to all applicable copyright laws and is not for resale in any manner.

## ADDITIONAL INFORMATION

### TECHNICAL PUBLICATIONS:

Technical Library: [www.onsemi.com/design/resources/technical-documentation](http://www.onsemi.com/design/resources/technical-documentation)  
onsemi Website: [www.onsemi.com](http://www.onsemi.com)

### ONLINE SUPPORT: [www.onsemi.com/support](http://www.onsemi.com/support)

For additional information, please contact your local Sales Representative at [www.onsemi.com/support/sales](http://www.onsemi.com/support/sales)

## Looking for pricing, stock, or lifecycle information?

Click below to explore more details on WIN SOURCE:

 [View CS2841BED14 on WIN SOURCE](#)

 [ON Semiconductor](#) Information

## Optimize Your Supply Chain with WIN SOURCE Solutions

-  Global Sourcing Solution
-  Obsolete Management
-  Cost Control Management
-  Shortage Management
-  Alternative Solution
-  Excess Inventory Management