



**THE DATASHEET OF
DG454EY-T1-E3**



High Voltage 4 Ω Quad SPST CMOS Analog Switch

DESCRIPTION

The DG454 series has four independently selectable high voltage (44 V) SPST switches, each with a typical on resistance of 4 Ω and a typical flatness of 0.2 Ω, ideal parameters for low distortion audio signal switching.

The DG454 (NC) and DG455 (NO) are identical except for the digital logic control input, which is inverted as shown in the Truth Table. The DG456 has two normally closed and two normally open switches.

These are high voltage switches that are fully specified with dual supplies at ± 5 V and ± 15 V and a single supply of 12 V.

Fast switching speeds coupled with high signal bandwidth makes these parts suitable for video switching applications.

All digital inputs have 0.8 V and 2.4 V logic thresholds ensuring low voltage TTL/CMOS compatibility. Each switch conducts equally well in both directions when on and can handle an input signal range that extends to the supply voltage rails.

The DG454 DG455 and DG456 are pin compatible with the DG411, DG412 and DG413, except they require no V_L supply.

FEATURES

- Low on-resistance (4 Ω typical)
- On-resistance flatness (0.2 Ω typical)
- 100 mA continuous current
- 44 V supply maximum rating
- ± 15 V analog signal range
- Fully specified at supply voltages of ± 5 V, 12 V and ± 15 V
- No V_L required
- Fast switching speed:
 - t_{on} 80 ns
 - t_{off} 60 ns
- TTL/CMOS compatible
- ESD protection 2 kV
- Pin compatible with DG411, DG412, and DG413, except no V_L required
- Material categorization: For definitions of compliance please see www.vishay.com/doc?99912



RoHS
COMPLIANT
HALOGEN
FREE

APPLICATIONS

- Audio and video signal switching
- Precision automatic test equipment
- Precision data acquisition
- Relay replacement
- Communications systems
- Automotive and avionics applications
- Sample and hold systems

FUNCTIONAL BLOCK DIAGRAM AND PIN CONFIGURATION

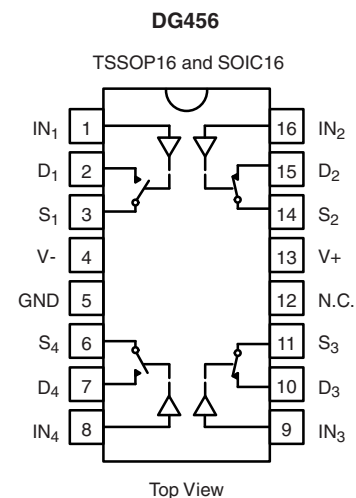
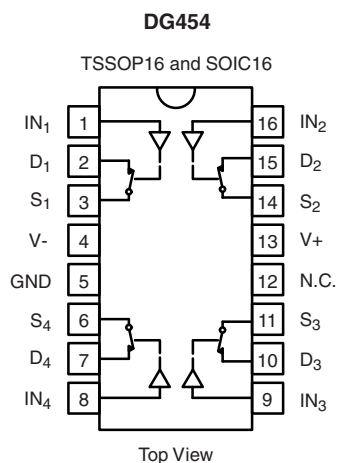

| TRUTH TABLE | | |
|-------------|-------|-------|
| Logic | DG454 | DG455 |
| 0 | On | Off |
| 1 | Off | On |

| TRUTH TABLE | | |
|-------------|-----------------------------------|-----------------------------------|
| Logic | SW ₁ , SW ₄ | SW ₂ , SW ₃ |
| 0 | Off | On |
| 1 | On | Off |

| ORDERING INFORMATION | | |
|--------------------------------|--------------------|---|
| Temp. Range | Package | Part Number |
| DG454, DG455, DG456 | | |
| - 40 °C to 125 °C ^a | 16 Pin TSSOP | DG454EQ-T1-E3 DG455EQ-T1-E3 DG456EQ-T1-E3 |
| | 16 Pin Narrow SOIC | DG454EY-T1-E3 DG455EY-T1-E3 DG456EY-T1-E3 |

Notes:

a. - 40 °C to 85 °C datasheet limits apply.

| ABSOLUTE MAXIMUM RATINGS (T _A = 25 °C, unless otherwise noted) | | | |
|---|---------------------------------|--|------|
| Parameter | | Limit | Unit |
| V ₊ to V ₋ | | 44 | V |
| GND to V ₋ | | 25 | |
| Digital Inputs ^a , V _S , V _D | | (V ₋) - 2 to (V ₊) + 2 or 30 mA, whichever occurs first | |
| Continuous Current (D, S only) | | 100 | mA |
| Peak Current, S or D (Pulsed 1 ms, 10 % Duty Cycle) | | 300 | |
| Storage Temperature | | - 65 to 150 | °C |
| Power Dissipation (Package) ^b | 16 Pin TSSOP ^c | 450 | mW |
| | 16 Pin Narrow SOIC ^d | 600 | |
| Thermal Resistance (Package) ^b | 16 Pin TSSOP | 178 | °C/W |
| | 16 Pin Narrow SOIC | 125 | |
| ESD (HBM) | | 2 | kV |

Notes:

a. Signals on S_X, D_X, or IN_X exceeding V₊ or V₋ will be clamped by internal diodes. Limit forward diode current to maximum current ratings.

b. All leads welded or soldered to PC board.

c. Derate 5.6 mW/°C above 70 °C.

d. Derate 8 mW/°C above 75 °C.

| SPECIFICATIONS FOR DUAL SUPPLIES | | | | | | | | | |
|----------------------------------|-----------------------|--|--------------------|-------------------|-------------------|-------------------|-------------------|-------------------|------|
| Parameter | Symbol | Test Conditions Unless Specified V ₊ = 15 V, V ₋ = - 15 V V _{IN} = 2.4 V, 0.8 V ^a | Temp. ^b | Typ. ^c | - 40 °C to 125 °C | | - 40 °C to 85 °C | | Unit |
| | | | | | Min. ^d | Max. ^d | Min. ^d | Max. ^d | |
| Analog Switch | | | | | | | | | |
| Analog Signal Range ^e | V _{ANALOG} | | Full | | - 15 | 15 | - 15 | 15 | V |
| On-Resistance | R _{ON} | I _S = - 10 mA, V _D = - 10 V to + 10 V | Room Full | 3.8 | | 5.3 8.3 | | 5.3 7.3 | Ω |
| On-Resistance Match | ΔR _{ON} | I _S = - 10 mA, V _D = ± 10 V | Room Full | 0.12 | | 0.5 1 | | 0.5 0.5 | |
| On-Resistance Flatness | R _{FLATNESS} | I _S = - 10 mA, V _D = - 5 V, 0 V, + 5 V | Room Full | 0.25 | | 0.5 0.5 | | 0.5 0.5 | |
| Switch Off Leakage Current | I _{S(off)} | V _D = ± 10 V, V _S = 10 V ⊘ | Room Full | ± 0.1 | - 0.5 - 20 | 0.5 20 | - 0.5 - 2.5 | 0.5 2.5 | nA |
| | I _{D(off)} | | Room Full | ± 0.1 | - 0.5 - 20 | 0.5 20 | - 0.5 - 2.5 | 0.5 2.5 | |
| Channel On Leakage Current | I _{D(on)} | V _S = V _D = ± 10 V | Room Full | ± 0.1 | - 1 - 40 | 1 40 | - 1 - 5 | 1 5 | |



SPECIFICATIONS FOR DUAL SUPPLIES

| Parameter | Symbol | Test Conditions Unless Specified V ₊ = 15 V, V ₋ = - 15 V V _{IN} = 2.4 V, 0.8 V ^a | Temp. ^b | Typ. ^c | - 40 °C to 125 °C | | - 40 °C to 85 °C | | Unit |
|---|---------------------|--|--------------------|-------------------|-------------------|-------------------|-------------------|-------------------|------|
| | | | | | Min. ^d | Max. ^d | Min. ^d | Max. ^d | |
| Digital Control | | | | | | | | | |
| Input Current, V _{IN} Low | I _{IL} | V _{IN} Under Test = 0.8 V | Full | 0.005 | - 0.5 | 0.5 | - 0.5 | 0.5 | μA |
| Input Current, V _{IN} High | I _{IH} | V _{IN} Under Test = 2.4 V | Full | 0.005 | - 0.5 | 0.5 | - 0.5 | 0.5 | |
| Input Capacitance ^e | C _{IN} | f = 1 MHz | Room | 7 | | | | | pF |
| Dynamic Characteristics | | | | | | | | | |
| Turn-On Time | t _{ON} | R _L = 300 Ω, C _L = 35 pF V _S = ± 10 V, See Figure 2 | Room | 88 | | 118 | | 118 | ns |
| Turn-Off Time | t _{OFF} | | Full | 69 | | 97 | | 97 | |
| Break-Before-Make Time Delay | t _D | DG456 only, V _S = 10 V R _L = 300 Ω, C _L = 35 pF | Room | 18 | | | | | |
| Charge Injection ^e | Q | V _g = 0 V, R _g = 0 Ω, C _L = 1 nF | Room | 22 | | | | | pC |
| Off Isolation ^e | OIRR | R _L = 50 Ω, C _L = 5 pF f = 1 MHz | Room | - 60 | | | | | dB |
| Channel-to-Channel Crosstalk ^e | X _{TALK} | | Room | - 85 | | | | | |
| Source Off Capacitance ^e | C _{S(off)} | f = 1 MHz | Room | 31 | | | | | pF |
| Drain Off Capacitance ^e | C _{D(off)} | | Room | 34 | | | | | |
| Channel On Capacitance ^e | C _{D(on)} | | Room | 103 | | | | | |
| Total Harmonic Distortion ^e | THD | Signal = 5 V _{RMS} , 20 Hz to 20 kHz, R _L = 600 Ω | Room | 0.04 | | | | | % |
| Power Supplies | | | | | | | | | |
| Power Supply Current | I ₊ | V ₊ = 16.5 V, V ₋ = - 16.5 V V _{IN} = 0 or 5 V | Room | 25 | | 100 | | 100 | μA |
| Negative Supply Current | I ₋ | | Full | - 0.001 | - 0.5 | | - 0.5 | | |
| Ground Current | I _{GND} | | Full | - 25 | - 100 | | - 100 | | |

SPECIFICATIONS FOR DUAL SUPPLIES

| Parameter | Symbol | Test Conditions Unless Specified V ₊ = 5 V, V ₋ = - 5 V V _{IN} = 2.4 V, 0.8 V ^a | Temp. ^b | Typ. ^c | - 40 °C to 125 °C | | - 40 °C to 85 °C | | Unit |
|---|---------------------|--|--------------------|-------------------|-------------------|-------------------|-------------------|-------------------|------|
| | | | | | Min. ^d | Max. ^d | Min. ^d | Max. ^d | |
| Analog Switch | | | | | | | | | |
| Analog Signal Range ^e | V _{ANALOG} | | Full | | - 5 | 5 | - 5 | 5 | V |
| On-Resistance | R _{ON} | V ₊ = + 5 V, V ₋ = - 5 V I _S = - 10 mA, V _D = - 3.5 V to + 3.5 V | Room | 3.8 | | 11 | | 11 | Ω |
| On-Resistance Match | ΔR _{ON} | V ₊ = + 5 V, V ₋ = - 5 V, I _S = - 10 mA, V _D = ± 3.5 V | Room | 0.13 | | 0.5 | | 0.5 | |
| Dynamic Characteristics | | | | | | | | | |
| Turn-On Time ^e | t _{ON} | R _L = 300 Ω, C _L = 35 pF V _S = 3 V, See Figure 2 | Room | 170 | | 200 | | 200 | ns |
| Turn-Off Time ^e | t _{OFF} | | Full | 66 | | 96 | | 96 | |
| Break-Before-Make ^e Time Delay | t _D | DG456 only, V _S = 3 V R _L = 300 Ω, C _L = 35 pF | Room | 98 | | | | | |
| Charge Injection ^e | Q | V _g = 0 V, R _g = 0 Ω, C _L = 1 nF | Room | 8 | | | | | pC |

| SPECIFICATIONS FOR DUAL SUPPLIES | | | | | | | | | |
|----------------------------------|------------------|---|--------------------|-------------------|-------------------|-------------------|-------------------|-------------------|------|
| Parameter | Symbol | Test Conditions Unless Specified $V_+ = 5\text{ V}$, $V_- = -5\text{ V}$ $V_{IN} = 2.4\text{ V}$, 0.8 V^a | Temp. ^b | Typ. ^c | - 40 °C to 125 °C | | - 40 °C to 85 °C | | Unit |
| | | | | | Min. ^d | Max. ^d | Min. ^d | Max. ^d | |
| Power Supplies | | | | | | | | | |
| Power Supply Current | I+ | $V_{IN} = 0\text{ or }5\text{ V}$ | Room Full | 14 | | 100 100 | | 100 100 | μA |
| Negative Supply Current | I- | | Room Full | - 0.001 | - 0.5 - 5 | | - 0.5 - 5 | | |
| Ground Current | I _{GND} | | Room Full | - 14 | - 100 - 100 | | - 100 - 100 | | |

| SPECIFICATIONS FOR UNIPOLAR SUPPLIES | | | | | | | | | |
|--------------------------------------|-----------------------|---|--------------------|-------------------|-------------------|-------------------|-------------------|-------------------|------|
| Parameter | Symbol | Test Conditions Unless Specified $V_+ = 12\text{ V}$, $V_- = 0\text{ V}$ $V_{IN} = 2.4\text{ V}$, 0.8 V^a | Temp. ^b | Typ. ^c | - 40 °C to 125 °C | | - 40 °C to 85 °C | | Unit |
| | | | | | Min. ^d | Max. ^d | Min. ^d | Max. ^d | |
| Analog Switch | | | | | | | | | |
| Analog Signal Range ^e | V _{ANALOG} | | Full | | | 12 | | 12 | V |
| On-Resistance | R _{ON} | I _S = - 10 mA, V _D = 0 V to + 10 V | Room Full | 5.5 | | 8.1 12.4 | | 8.1 10.4 | Ω |
| On-Resistance Match | ΔR _{ON} | I _S = - 10 mA, V _D = + 10 V | Room Full | 0.14 | | 0.5 1 | | 0.5 0.5 | |
| On-Resistance Flatness | R _{FLATNESS} | I _S = - 10 mA, V _D = 0 V, + 5 V, + 10 V | Room Full | 0.94 | | 1.5 1.7 | | 1.5 1.5 | |
| Dynamic Characteristics | | | | | | | | | |
| Turn-On Time | t _{ON} | R _L = 300 Ω, C _L = 35 pF V _S = 8 V, See Figure 2 | Room Full | 132 | | 162 238 | | 162 210 | ns |
| Turn-Off Time | t _{OFF} | | Room Full | 61 | | 91 117 | | 91 105 | |
| Break-Before-Make Time Delay | t _D | DG456 only, V _S = 8 V R _L = 300 Ω, C _L = 35 pF | Room | 70 | | | | | |
| Charge Injection ^e | Q | V _g = 0 V, R _g = 0 Ω, C _L = 1 nF | Room | 1 | | | | | pC |
| Power Supplies | | | | | | | | | |
| Power Supply Current | I+ | $V_+ = 13.5\text{ V}$, $V_- = 0\text{ V}$ $V_{IN} = 0\text{ or }5\text{ V}$ | Room Full | 25 | | 100 100 | | 100 100 | μA |
| Negative Supply Current | I- | | Room Full | - 0.001 | - 0.5 - 5 | | - 0.5 - 5 | | |
| Ground Current | I _{GND} | | Room Full | - 25 | - 100 - 100 | | - 100 - 100 | | |

Notes:

- V_{IN} = input voltage to perform proper function.
- Room = 25 °C, Full = as determined by the operating temperature suffix.
- Typical values are for DESIGN AID ONLY, not guaranteed nor subject to production testing.
- The algebraic convention whereby the most negative value is a minimum and the most positive a maximum, is used in this data sheet.
- Guaranteed by design, not subject to production test.

Stresses beyond those listed under "Absolute Maximum Ratings" may cause permanent damage to the device. These are stress ratings only, and functional operation of the device at these or any other conditions beyond those indicated in the operational sections of the specifications is not implied. Exposure to absolute maximum rating conditions for extended periods may affect device reliability.

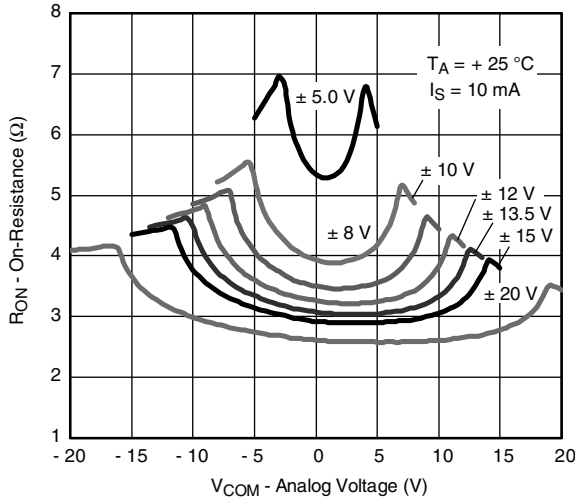
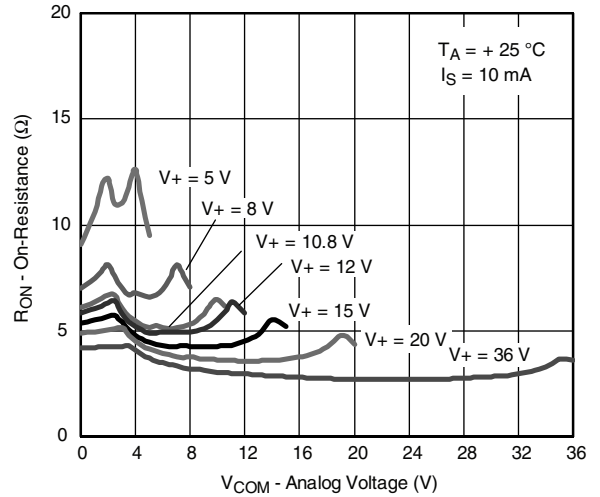
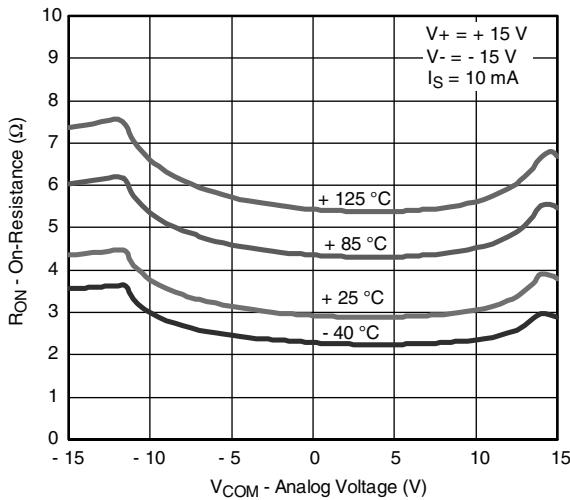
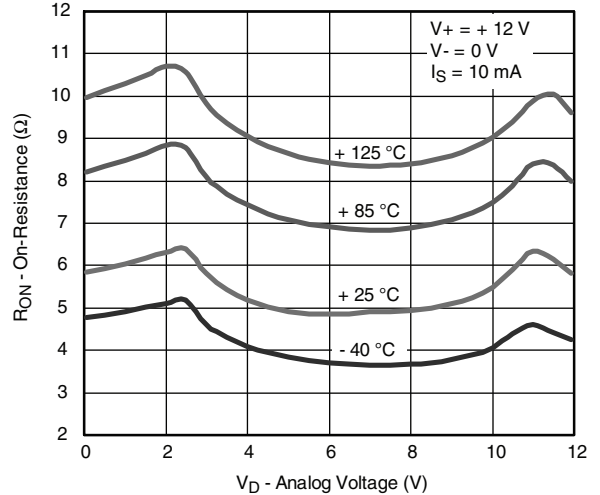
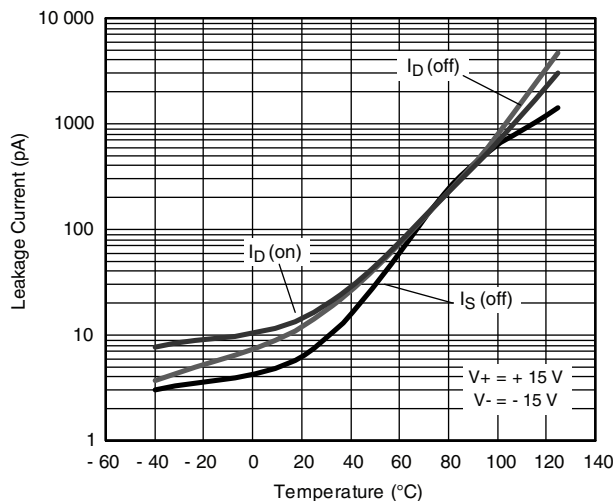
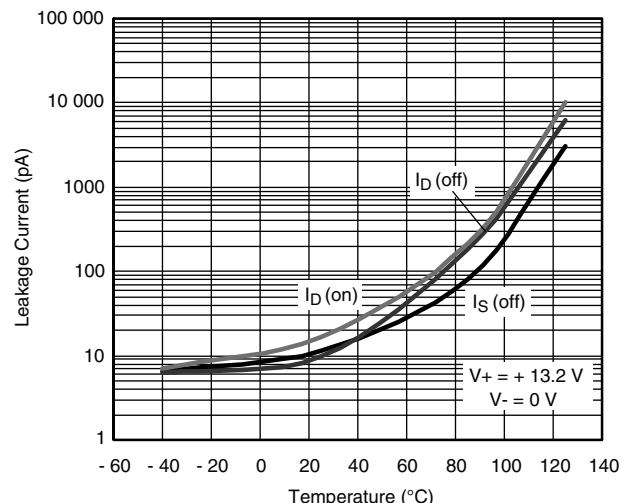
TYPICAL CHARACTERISTICS (25 °C, unless otherwise noted)

On-Resistance vs. V_D and Dual Supply Voltage

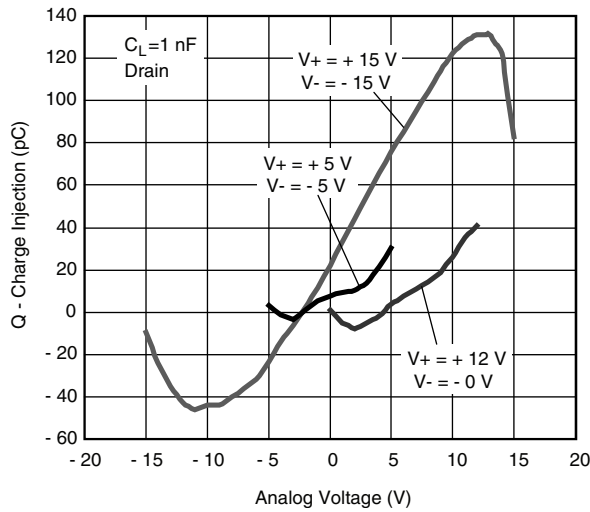
On-Resistance vs. V_D and Single Supply Voltage

On-Resistance vs. V_D and Temperature

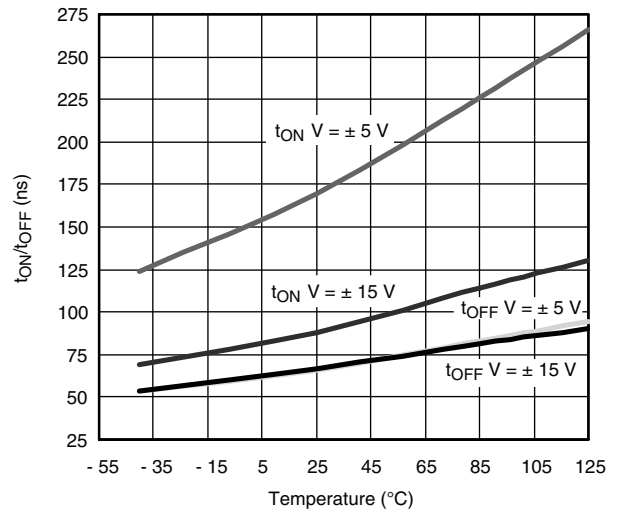
On-Resistance vs. V_D and Temperature

Leakage Current vs. Temperature

Leakage Current vs. Temperature

TYPICAL CHARACTERISTICS (25 °C, unless otherwise noted)



Charge Injection vs. Analog Voltage



Switching Time vs. Temperature and Dual Supply Voltage

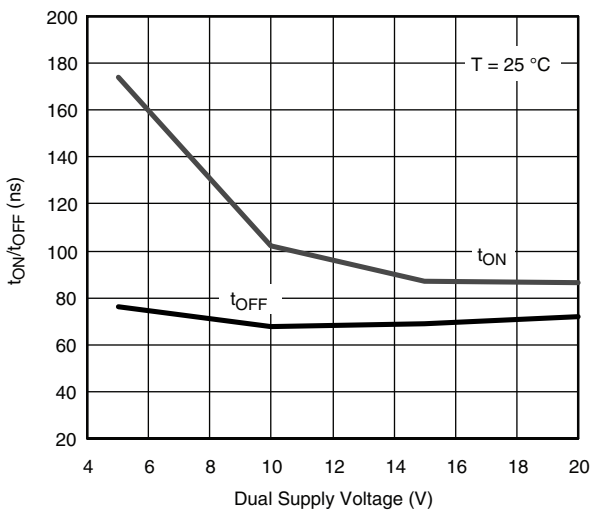

Switching Time vs. Dual Supply Voltage

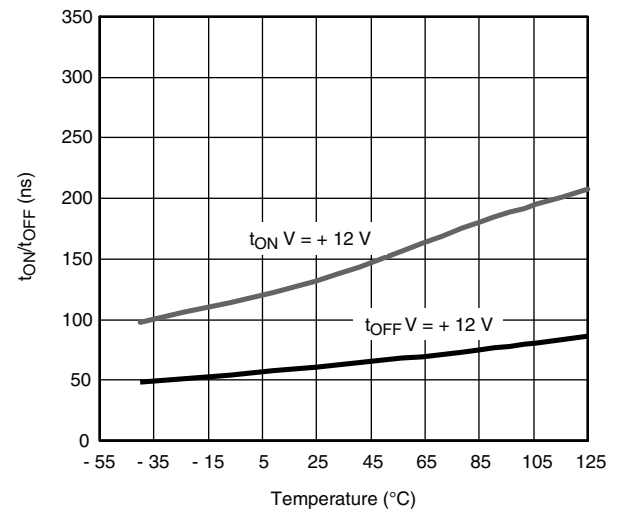

Switching Time vs. Temperature and Single Supply Voltage

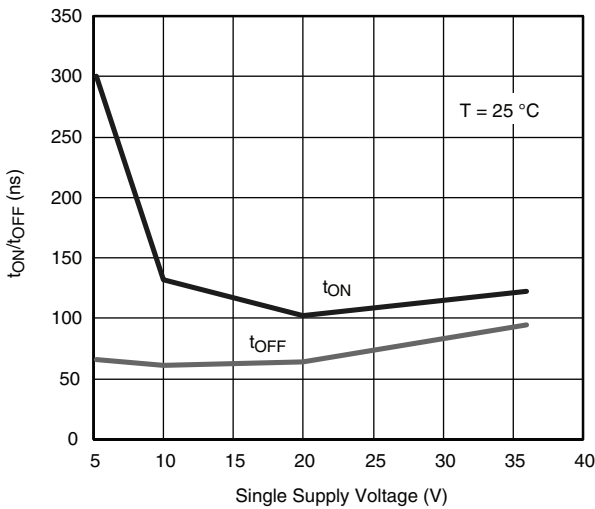

Switching Time vs. Single Supply Voltage

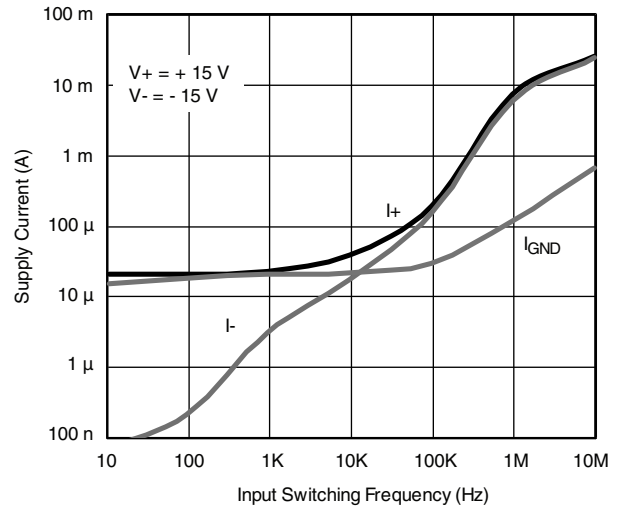

Supply Current vs. Input Switching Frequency

TYPICAL CHARACTERISTICS (25 °C, unless otherwise noted)

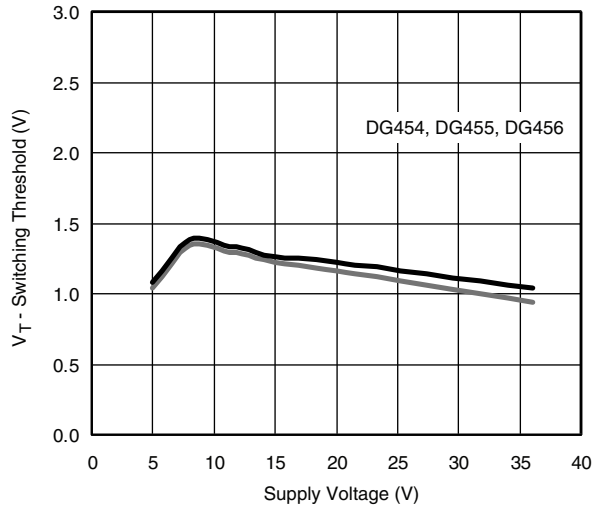

Switching Threshold vs. Supply Voltage

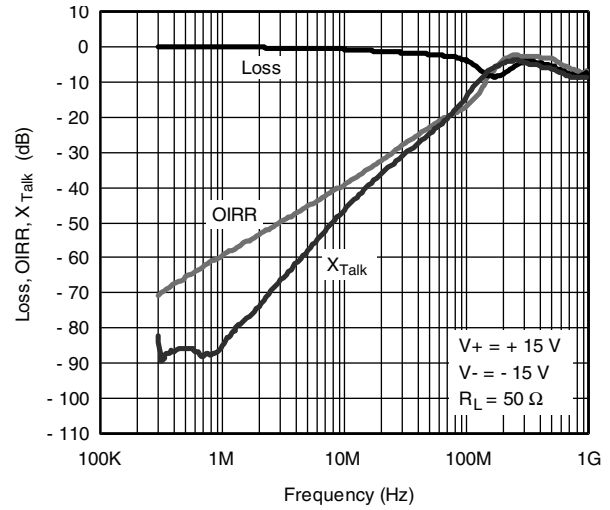

Insertion Loss, Off-Isolation, Crosstalk vs. Frequency

TEST CIRCUITS

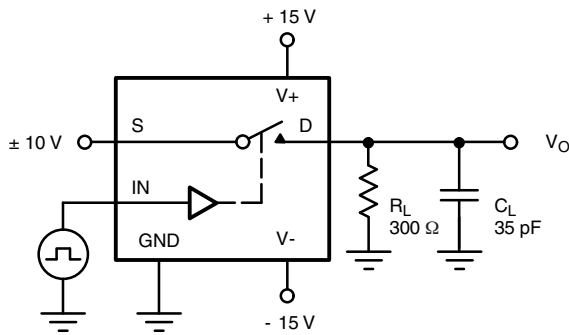

C_L (includes fixture and stray capacitance)

$$V_O = V_S \frac{R_L}{R_L + R_{DS(on)}}$$

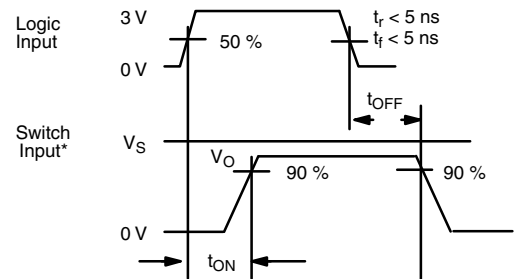

Note: Logic input waveform is inverted for switches that have the opposite logic sense control

Figure 1. Switching Time

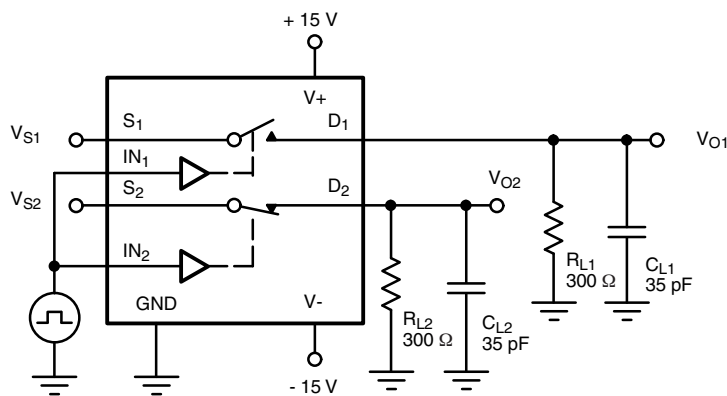

C_L (includes fixture and stray capacitance)

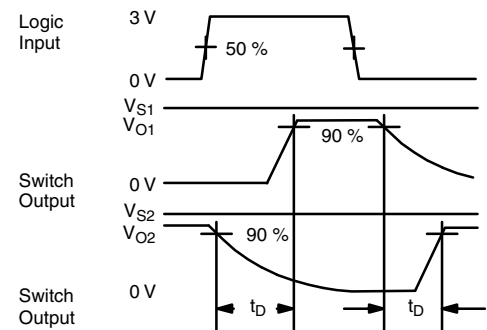

Figure 2. Break-Before-Make (DG456)

TEST CIRCUITS

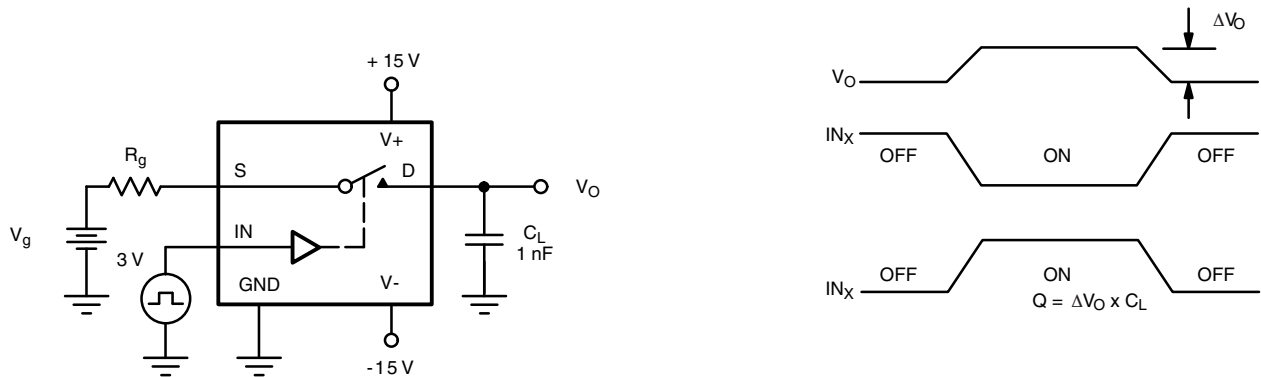

Figure 3. Charge Injection

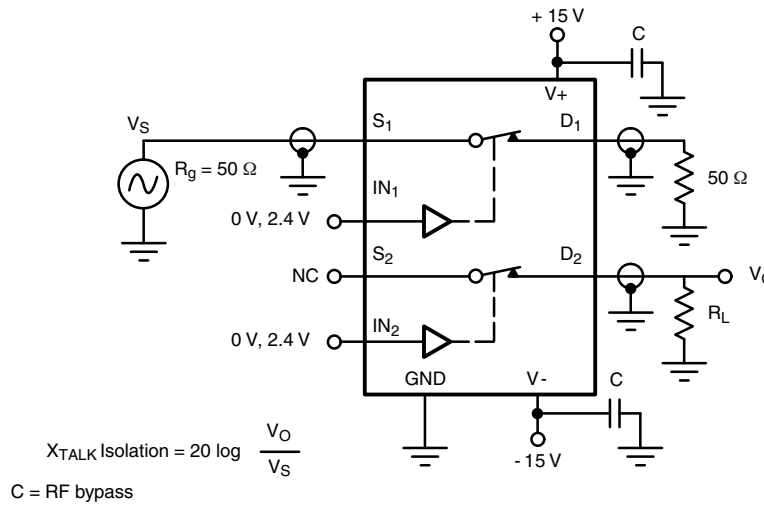

Figure 4. Crosstalk

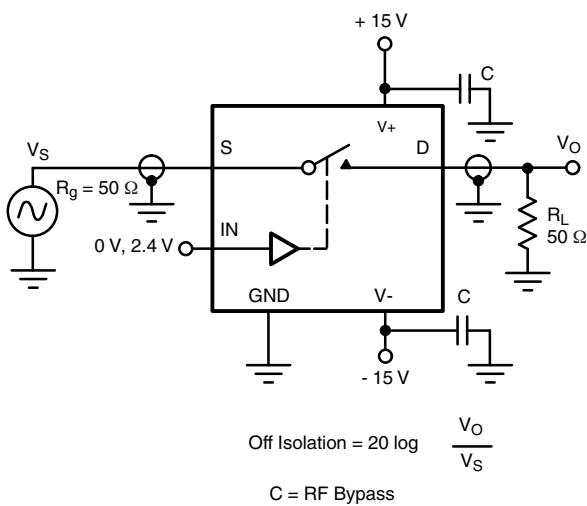

Figure 5. Off-Isolation

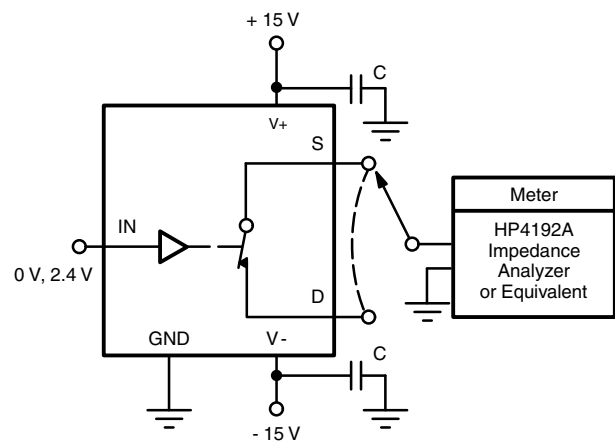

Figure 6. Source/Drain Capacitances

Vishay Siliconix maintains worldwide manufacturing capability. Products may be manufactured at one of several qualified locations. Reliability data for Silicon Technology and Package Reliability represent a composite of all qualified locations. For related documents such as package/tape drawings, part marking, and reliability data, see www.vishay.com/ppg?74473.



SOIC (NARROW): 16-LEAD
JEDEC Part Number: MS-012



| Dim | MILLIMETERS | | INCHES | |
|----------------|-------------|-------|-----------|-------|
| | Min | Max | Min | Max |
| A | 1.35 | 1.75 | 0.053 | 0.069 |
| A ₁ | 0.10 | 0.20 | 0.004 | 0.008 |
| B | 0.38 | 0.51 | 0.015 | 0.020 |
| C | 0.18 | 0.23 | 0.007 | 0.009 |
| D | 9.80 | 10.00 | 0.385 | 0.393 |
| E | 3.80 | 4.00 | 0.149 | 0.157 |
| e | 1.27 BSC | | 0.050 BSC | |
| H | 5.80 | 6.20 | 0.228 | 0.244 |
| L | 0.50 | 0.93 | 0.020 | 0.037 |
| ∅ | 0° | 8° | 0° | 8° |

ECN: S-03946—Rev. F, 09-Jul-01
DWG: 5300



TSSOP: 16-LEAD

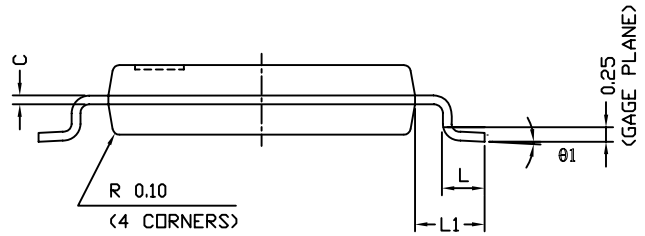
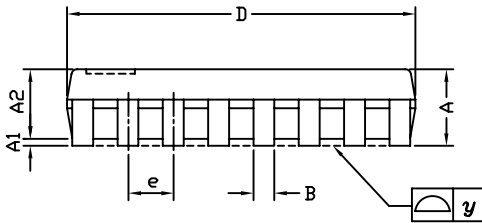
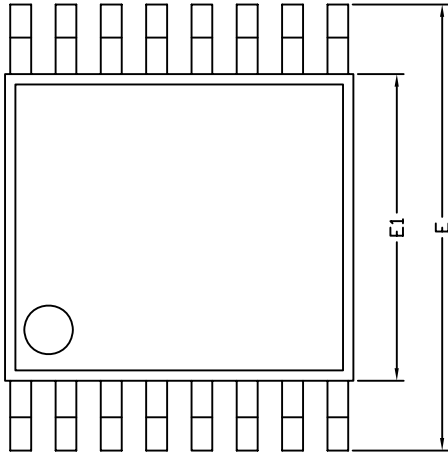

| Symbols | DIMENSIONS IN MILLIMETERS | | |
|---------|---------------------------|-------|------|
| | Min | Nom | Max |
| A | - | 1.10 | 1.20 |
| A1 | 0.05 | 0.10 | 0.15 |
| A2 | - | 1.00 | 1.05 |
| B | 0.22 | 0.28 | 0.38 |
| C | - | 0.127 | - |
| D | 4.90 | 5.00 | 5.10 |
| E | 6.10 | 6.40 | 6.70 |
| E1 | 4.30 | 4.40 | 4.50 |
| e | - | 0.65 | - |
| L | 0.50 | 0.60 | 0.70 |
| L1 | 0.90 | 1.00 | 1.10 |
| y | - | - | 0.10 |
| θ1 | 0° | 3° | 6° |

ECN: S-61920-Rev. D, 23-Oct-06
DWG: 5624



RECOMMENDED MINIMUM PAD FOR TSSOP-16

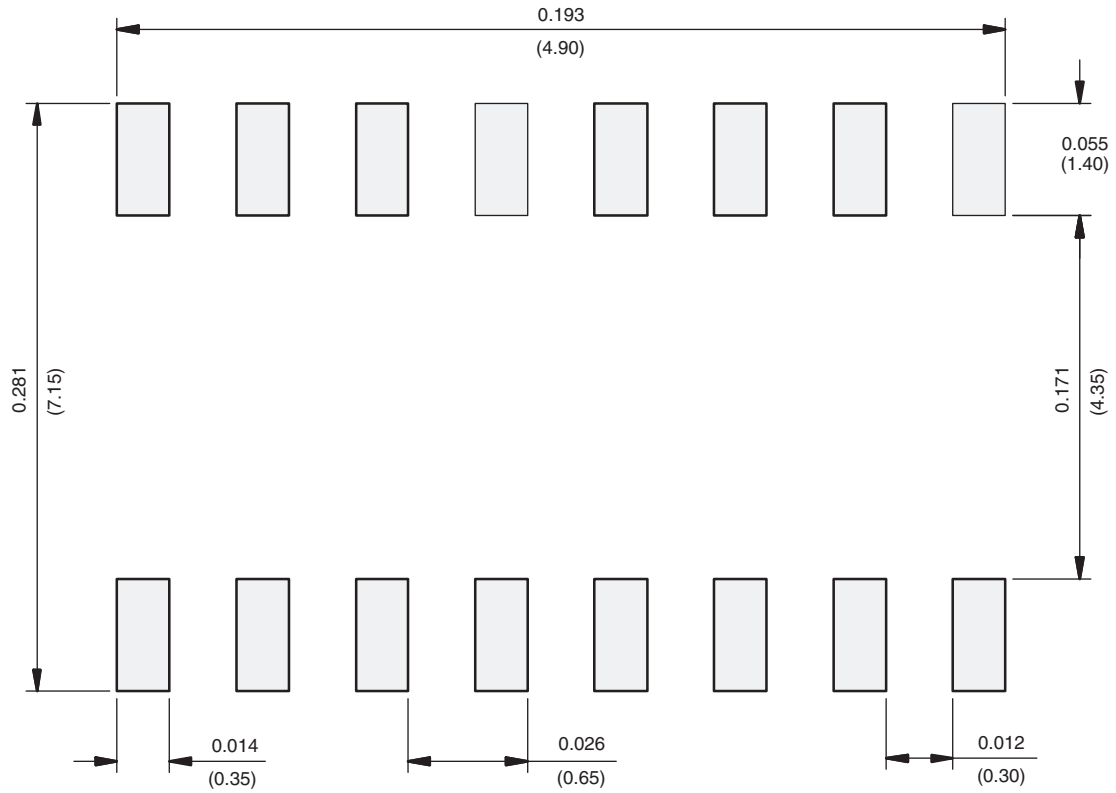

Recommended Minimum Pads
Dimensions in inches (mm)

RECOMMENDED MINIMUM PADS FOR SO-16

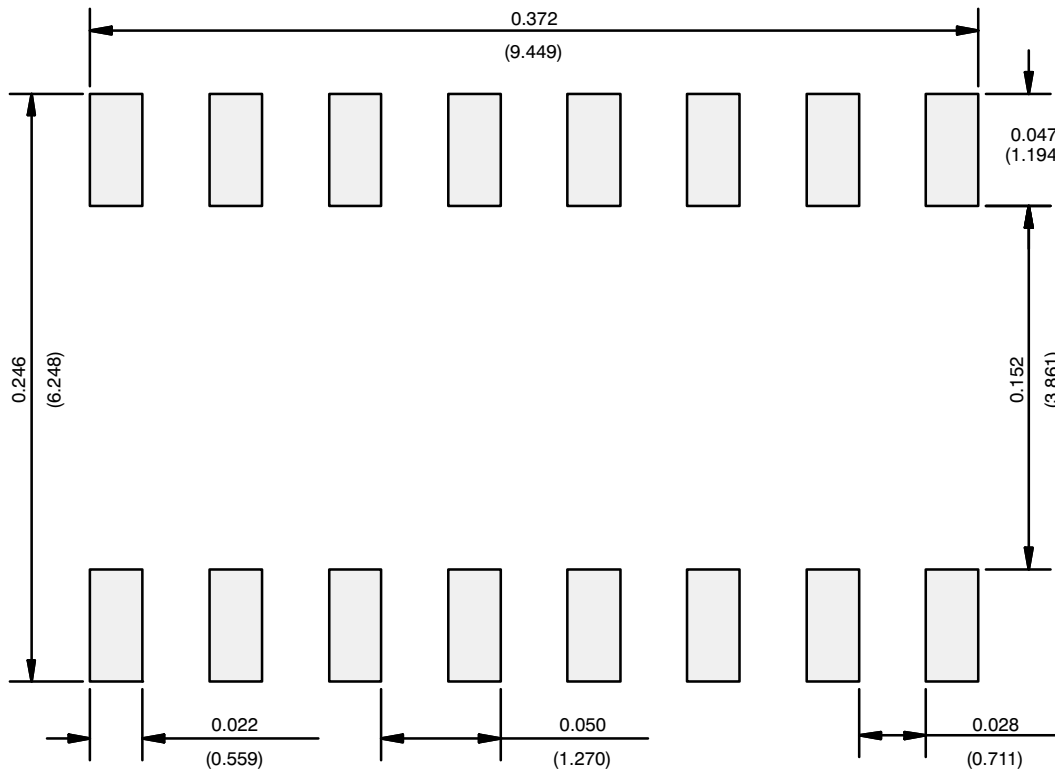

Recommended Minimum Pads
Dimensions in Inches/(mm)

[Return to Index](#)



Disclaimer

ALL PRODUCT, PRODUCT SPECIFICATIONS AND DATA ARE SUBJECT TO CHANGE WITHOUT NOTICE TO IMPROVE RELIABILITY, FUNCTION OR DESIGN OR OTHERWISE.

Vishay Intertechnology, Inc., its affiliates, agents, and employees, and all persons acting on its or their behalf (collectively, "Vishay"), disclaim any and all liability for any errors, inaccuracies or incompleteness contained in any datasheet or in any other disclosure relating to any product.

Vishay makes no warranty, representation or guarantee regarding the suitability of the products for any particular purpose or the continuing production of any product. To the maximum extent permitted by applicable law, Vishay disclaims (i) any and all liability arising out of the application or use of any product, (ii) any and all liability, including without limitation special, consequential or incidental damages, and (iii) any and all implied warranties, including warranties of fitness for particular purpose, non-infringement and merchantability.

Statements regarding the suitability of products for certain types of applications are based on Vishay's knowledge of typical requirements that are often placed on Vishay products in generic applications. Such statements are not binding statements about the suitability of products for a particular application. It is the customer's responsibility to validate that a particular product with the properties described in the product specification is suitable for use in a particular application. Parameters provided in datasheets and / or specifications may vary in different applications and performance may vary over time. All operating parameters, including typical parameters, must be validated for each customer application by the customer's technical experts. Product specifications do not expand or otherwise modify Vishay's terms and conditions of purchase, including but not limited to the warranty expressed therein.

Except as expressly indicated in writing, Vishay products are not designed for use in medical, life-saving, or life-sustaining applications or for any other application in which the failure of the Vishay product could result in personal injury or death. Customers using or selling Vishay products not expressly indicated for use in such applications do so at their own risk. Please contact authorized Vishay personnel to obtain written terms and conditions regarding products designed for such applications.

No license, express or implied, by estoppel or otherwise, to any intellectual property rights is granted by this document or by any conduct of Vishay. Product names and markings noted herein may be trademarks of their respective owners.

Looking for pricing, stock, or lifecycle information?

Click below to explore more details on WIN SOURCE:

 [View DG454EY-T1-E3 on WIN SOURCE](#)

 [Vishay Information](#)

Optimize Your Supply Chain with WIN SOURCE Solutions

-  Global Sourcing Solution
-  Obsolete Management
-  Cost Control Management
-  Shortage Management
-  Alternative Solution
-  Excess Inventory Management