

White LED Driver with PWM Brightness Control for up to 8 LEDs in Series



BD6067GU

●General Description

BD6067GU is boost DC/DC converters possible to boost output voltage up to 30V (Max.) and drive the white LEDs at constant. It is possible that turning on white LED steadily by a series connection which has no current variation, and by a fast transient response with current mode.

●Features

- Boost DC/DC converter
- Adjustment of brightness by external PWM pulse
- Possible to driving 8 LEDs in series
- Soft start function

●Key Specifications

- Operating power supply voltage range: 2.7V to 5.5V
- Switching frequency: 1.0MHz(Typ.)
- Quiescent Current: 0.1μA (Typ.)
- Operating temperature range: -30°C to +85°C

●Package W(Typ.) x D(Typ.) x H(Max.)

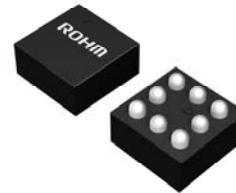

VCSP85H1
1.68mm x 1.68mm x 1.00mm

●Applications

These drivers are applicable for various fields such as mobile phones, portable game machines, Inter-phone camera, audio player, portable DVD player, back light for printer display etc... and support light of the camera for the mobile phone, simple flash. And, these can use power supply for OEL.

●Typical Application Circuit

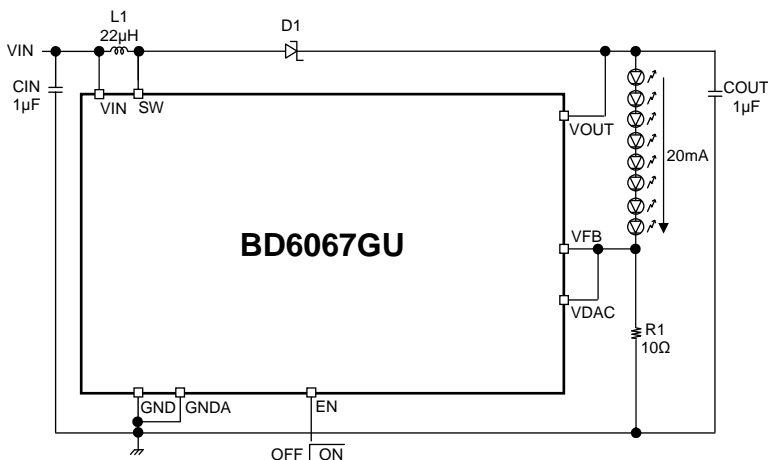

●Pin Configuration [Bottom View]

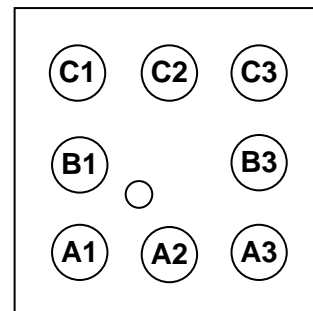

Figure 1. Pin Configuration

● Absolute Maximum Ratings (Ta=25°C)

Parameter	Symbol	Ratings	Unit	Conditions
Terminal voltage 1	VMAX1	7 *1	V	Applicable to VIN, EN, VFB and VDAC pins
Terminal voltage 2	VMAX2	40 *1	V	Applicable to SW and VOUT pins
Operating temperature range	Topr	-30 to +85	°C	
Storage temperature range	Tstg	-55 to +150	°C	
Power dissipation	Pd	800 *2	mW	50mmx58mmx1.75mm Glass epoxy PCB mounting

*1 This value is based on GND.

*2 This loss decreases approximate 6.4mW/°C when Ta is 25°C or more.

● Recommended Operating Ratings (Ta=-30°C to +85°C)

Parameter	Symbol	Ratings	Unit	Conditions
Operating supply voltage	VIN	2.7 to 5.5	V	VIN pin

● Electrical Characteristics (Unless otherwise stated, Ta = 25°C and VIN = 3.6V.)

Parameter	Symbol	Limits			Unit	Conditions
		Min.	Typ.	Max.		
<EN pin>						
'L' level input voltage	VthL	-	-	0.4	V	
'H' level input voltage	VthH	1.4	-	-	V	
'H' level input current	IiH	-	18.3	30.0	μA	EN=5.5V
'L' level input current	IiL	-2.0	-0.1	-	μA	EN=0V
<DAC control pin>						
VDAC-VFB resistance	V _{DAR}	56	112	168	kΩ	
<Switching regulator>						
Quiescent current	Iq	-	0.1	2.0	μA	EN=0V
Operating current	I _{dd}	-	0.9	1.4	mA	EN=3.6V, VFB=1.0V
VFB pin control voltage	VFB	0.18	0.20	0.22	V	
Over current limit	I _{coil}	450	600	750	mA	*1
SW transistor ON resistance	R _{onn}	-	0.5	1.4	Ω	I _{sw} =200mA
Switching frequency	f _{SW}	0.8	1.0	1.2	MHz	
Maximum duty	Duty	92.5	95.0	-	%	VFB=0V
Output voltage range	V _o	-	-	30.0	V	
Over voltage protection	Ovp	30.0	31.0	32.0	V	VFB=0V
Output open protection	Ovl	-	0.7	1.4	V	
Startup time	T _s	-	0.5	1.0	ms	VOUT=24V

*1 The DC current is measured in this item.

●Pin Description

Pin number	Pin name	In/Out	Function
A1	GNDA	-	Analog GND
A2	EN	In	Enable control (pull-down by internal resistance)
A3	VDAC	In	Analog signal input for current adjustment
B1	VIN	-	Supply voltage input
B3	VFB	In	Feedback voltage input
C1	VOUT	In	Over voltage protection input SBD open protection input
C2	SW	In	Switching pin
C3	GND	-	Power GND

●Block Diagram

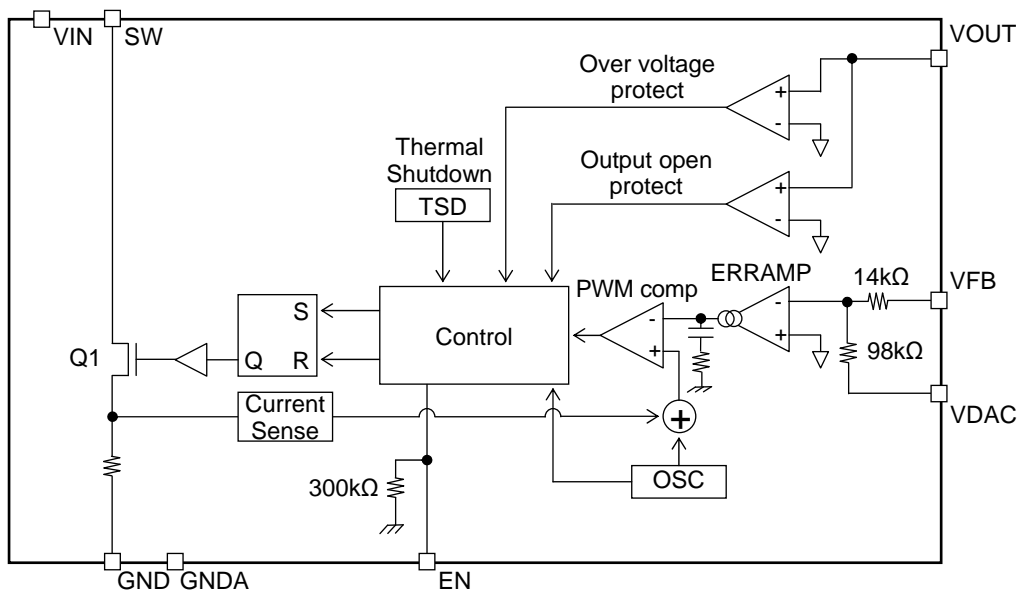

● Typical Performance Curves

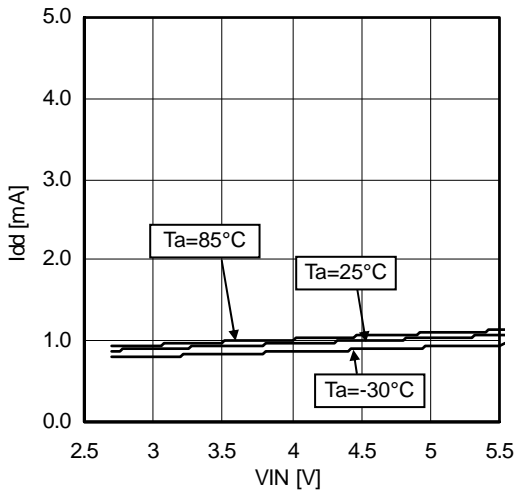

Figure 2. Operating current vs. Power Supply Voltage

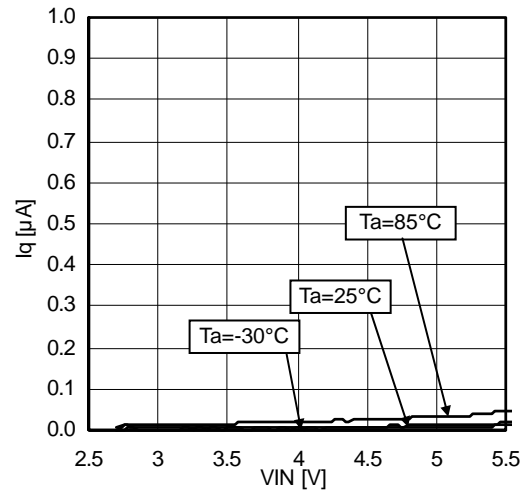

Figure 3. Quiescent current vs. Power Supply Voltage

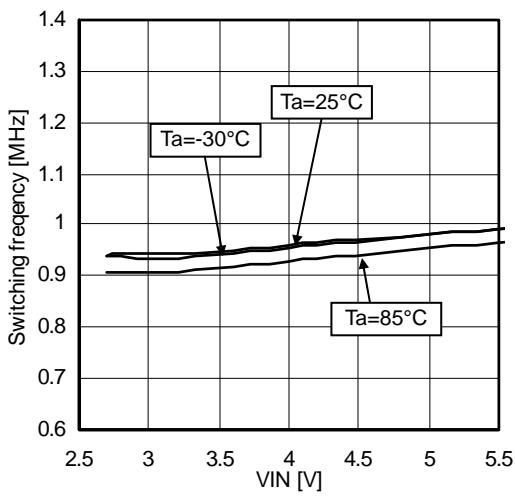

Figure 4. Oscillation Frequency vs. Power Supply Voltage

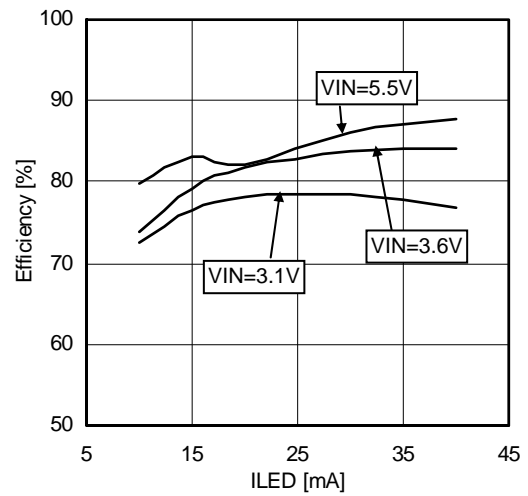

Figure 5. Efficiency vs. LED Current (6LED) (Ta=25°C)

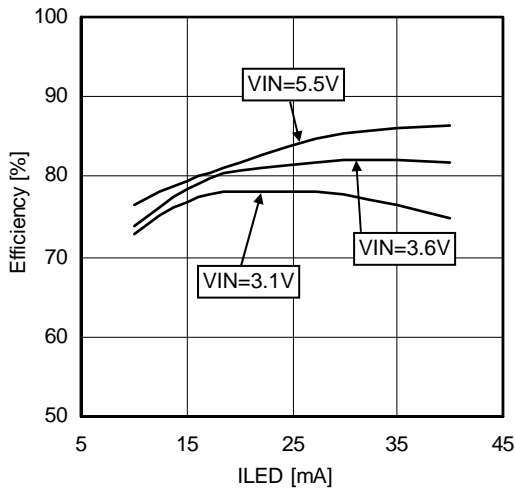

Figure 6. Efficiency vs. LED Current (7LED) (Ta=25°C)

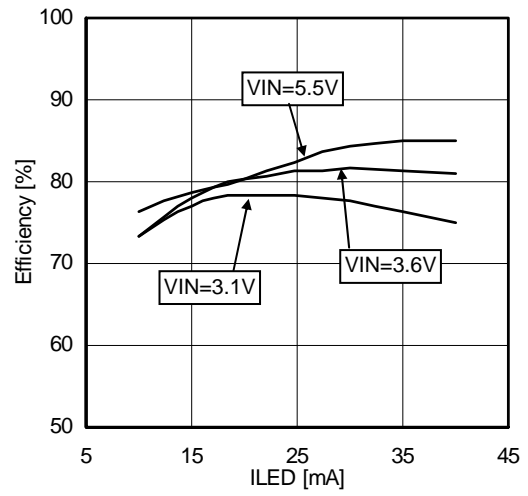

Figure 7. Efficiency vs. LED Current (8LED) (Ta=25°C)

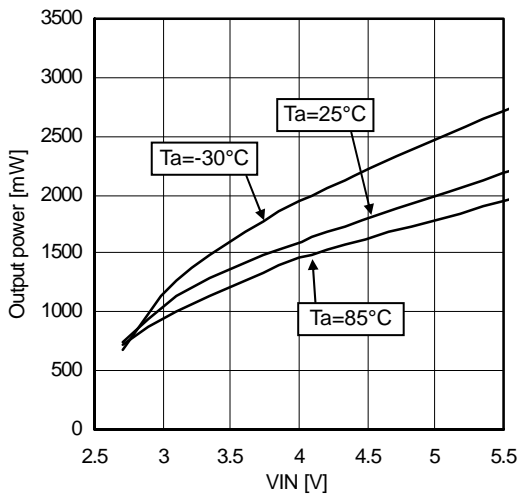

Figure 8. Output Voltage vs. Power Supply Voltage (8LED)

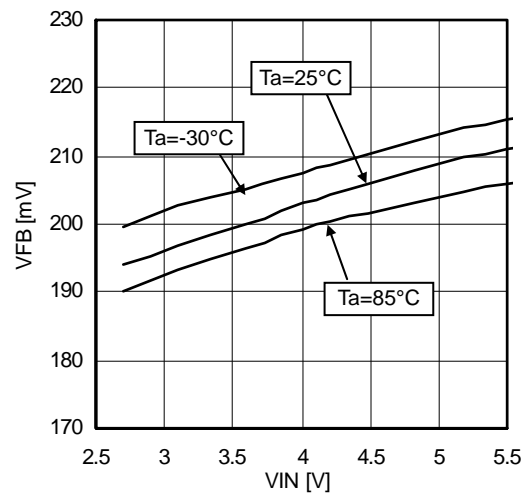

Figure 9. VFB Pin Control Voltage vs. Power Supply Voltage (8LED) (ILED=20mA)

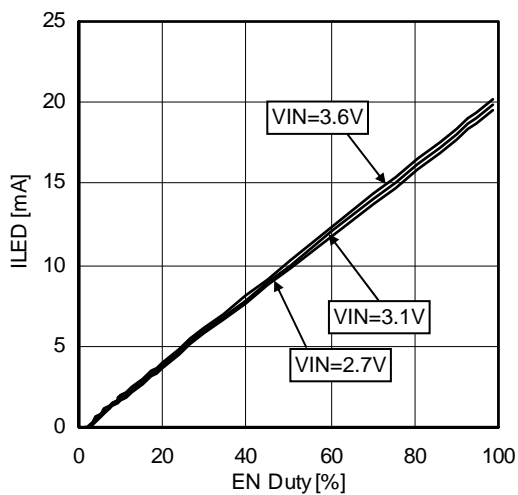

Figure 10. EN Pin PWM Brightness Control Characteristic (f=100Hz, Ta=25°C)

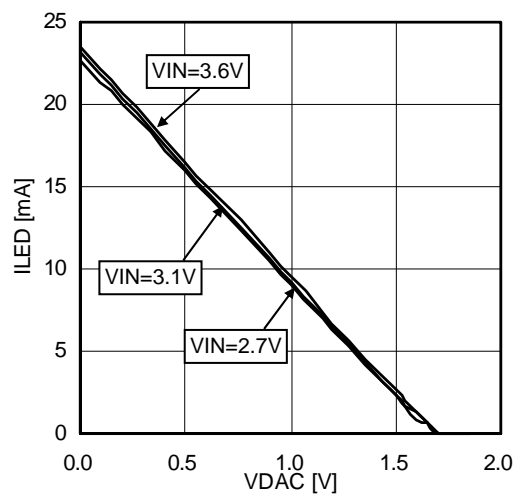

Figure 11. DAC Brightness Control Characteristic

●Release Circuit Protection

1)Operation

BD6067GU is a constant frequency PWM current mode DC/DC converter. It is shown in the block diagram of Page 3 In a PWM comparator forming one of the PWM current mode features, one is an error element from the error amplifier and another is an element produced by superimposing the inductor current on a slope waveform that prevents sub-harmonic oscillation. This output controls Q1 via the RS latch. Energy is stored in an external inductor while Q1 is ON and then it is moved to the COUT capacitor via D1 while Q1 is OFF. In this way, voltage VOUT higher than input voltage VIN can be obtained. Because the above operation is performed in a way that the VFB pin voltage equals the VFB voltage, the boost voltage is dominantly determined by the expression “Vf x number of LEDs.”

$$VOUT \text{ voltage} = (Vf \times \text{number of LEDs}) + VFB$$

2)LED current control

The LED current is determined depending on the VFB pin voltage “VFB” and the resistance connected to VFB. ILED is given below.

$$I_{LED} = 200\text{mV} / R1$$

I _{LED} [mA]	BD6067GU R1 [Ω]
5	39
10	20
12	16
15	13
20	10

3)Dimming control

▪ Control by PWM signal

The startup condition of BD6067GU is controlled via the EN pin. It is powered OFF at 0.4V or less and powered ON at 1.4V or more.

As shown in Figure 12, brightness is controlled in the BD6067GU via the PWM signal input the EN pin. In this way, the LED current is controlled in a range from 0 to the maximum current. The average LED current increases in proportion to the Duty cycle of the PWM signal. In the PWM off cycle, no current dissipation takes place in IC and LEDs, resulting in high efficiency. Duties below 5% and above 95% must not be used for brightness control because they significantly affects the leading and trailing edges. BD6067GU standard PWM frequency ranges from 100Hz to 300Hz.

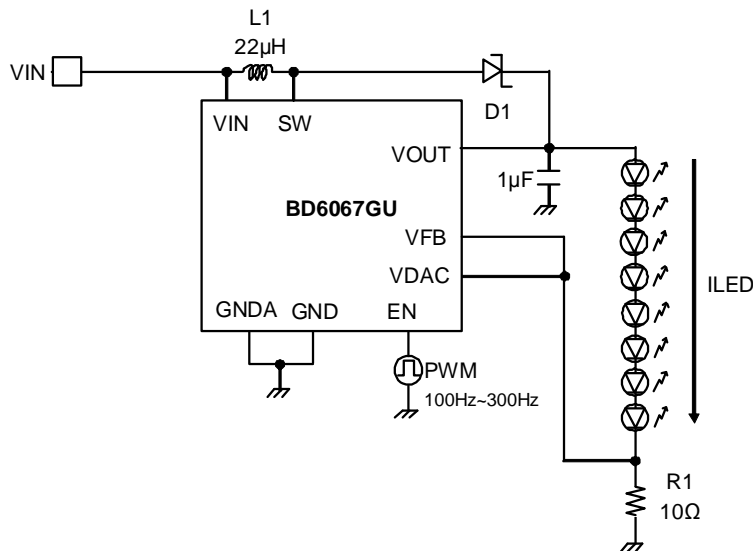

Figure 12. Example of Brightness Control by PWM signal at the EN Pin

- Control by DC Voltage
BD6067GU has a built-in function for LED current control by DC voltage and can control the current by VDAC pin control voltage.

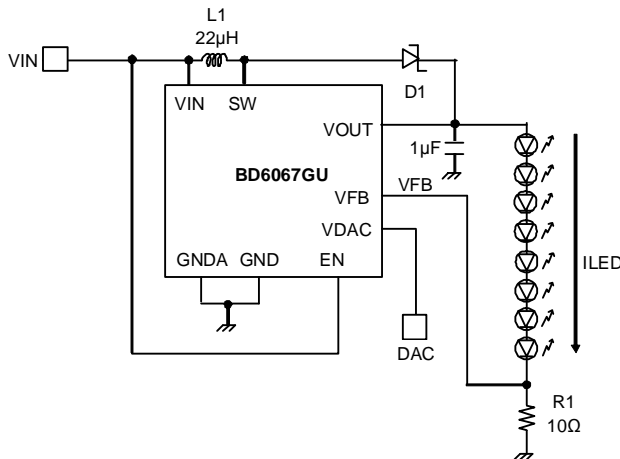

Figure 13. Brightness Control by BD6067GU DAC

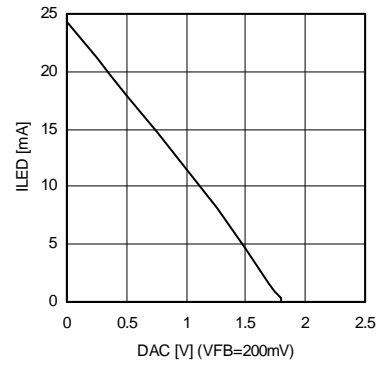

Figure 14. DAC Constant Current Characteristics by DAC Control

●Over voltage Protection

BD6067GU has an over voltage protection feature. When a fault occurs, for example, IC is disconnected from LED, an excessive voltage rise may cause the SW pin and VOUT pin to exceed the absolute maximum ratings respectively, resulting in IC damage. For this reason, when VOUT is 30V or more, over voltage protection is activated to turn Q1 off so that the SW pin and VOUT pin don't exceed the absolute maximum ratings. At this time, the IC state changes from active to inactive and the output voltage drops slowly. Then, when the output voltage falls below the over voltage protection hysteresis level, the output voltage continues to rise up to 30V again. This protection circuit is shown in Figure 15.

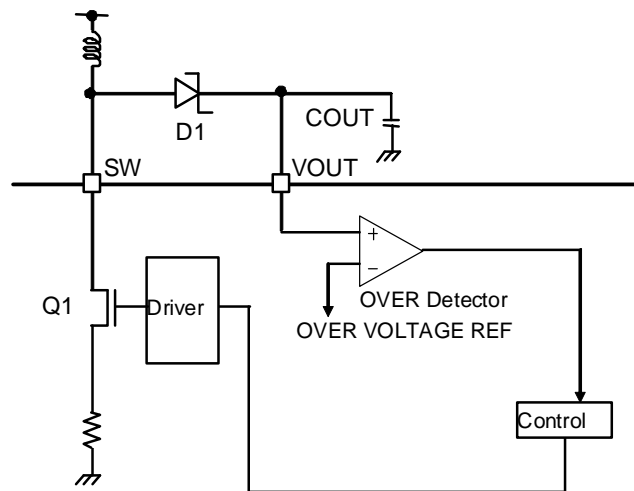

Figure 15. Block Diagram for Short-circuit Protection and over voltage Protection

● **Startup and Rush Current**

BD6067GU has a built-in soft start function. This function prevents the rush current from being generated at startup time.

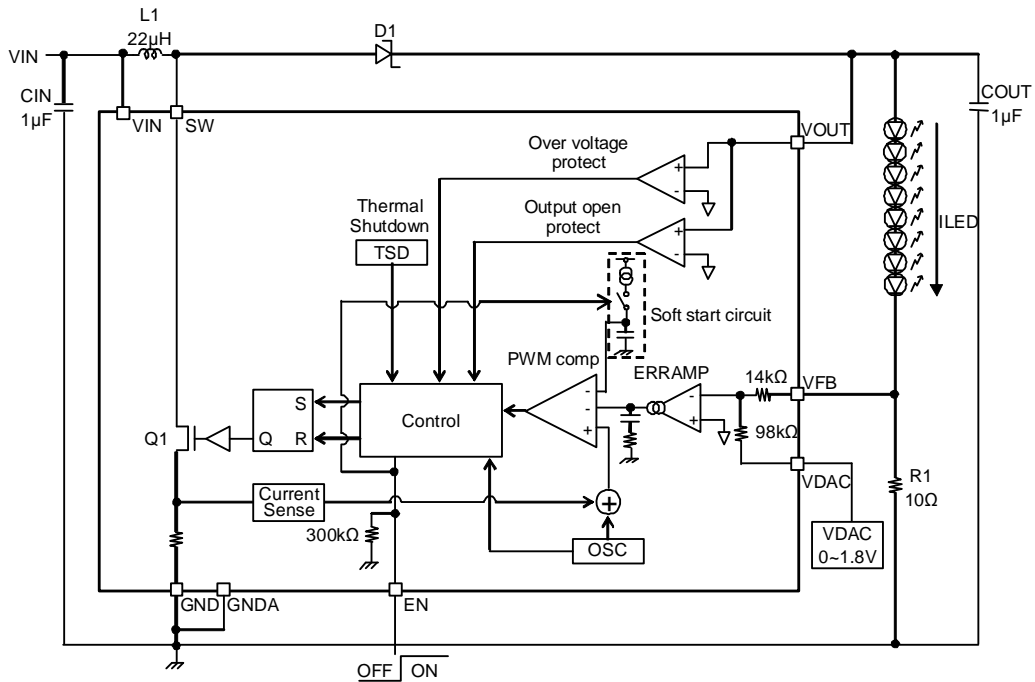

Figure 16. Soft Start Circuit

● **Application Circuit Example**

The output maximum voltage range of BD6067GU is 30V.

*** When LED has 8 lights, special care should be taken to prevent output voltage (VOUT) from exceeding 30V.

$$V_{OUT} = (LED\ V_f \times \text{number of LED lights}) + V_{FB}$$

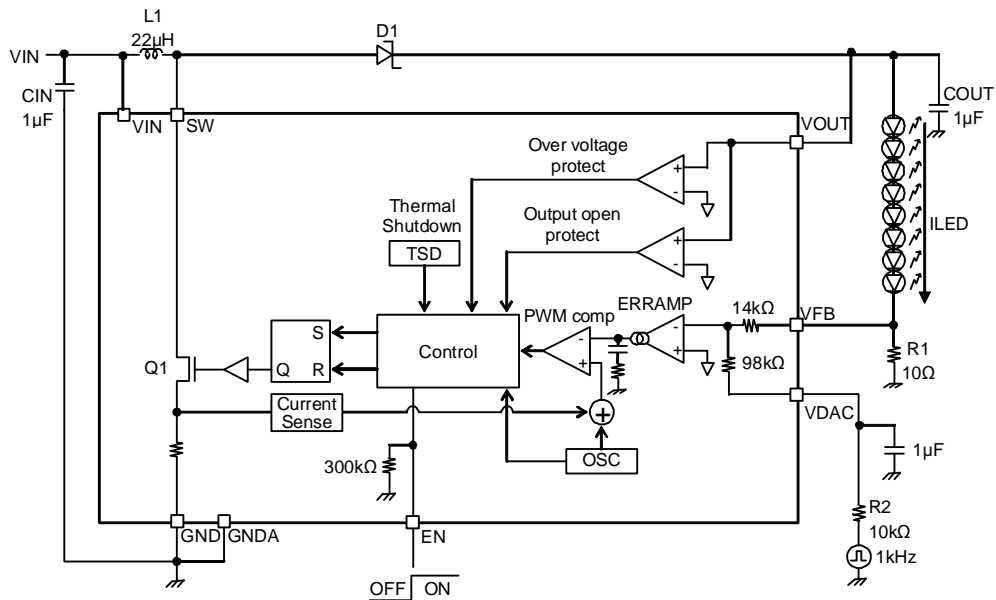

Figure 17. Example of Dimming Circuit Subject to PWM Control at the VDAC Pin

●External components Selection Method

<<Constants in the standard circuit example>>

R1: Determines the LED current ILED at power ON.

<Recommended parts>

ILED (mA)	R1[Ω]
5	39
15	13
20	10

L1: Coil for boost. The recommended value is 22μH. be sure to use a sufficient DC current permissible value and a sufficient low DC resistance coil.

<Recommended parts>

Inductance value	Model number/manufacturer
22μH	NR3015T220M / TAIYO YUDEN

CIN: Bypass capacitor of power supply. This capacitor must be provided to remove an instantaneous power supply noise for stable voltage supply to this IC. To obtain good characteristics, the low ESR parts like the ceramics capacitor must be used. The recommended capacitance is 1μF or more.

<Recommended parts>

Capacitance value	Model number/manufacturer
1.0μF	GRM188B11A105KA61B / MURATA

COUT: Output smoothing capacitor. The capacitance recommended for BD6067GU is 1.0μF.

<Recommended parts>

Capacitance value	Model number/manufacturer
1.0μF	UMK107C105KA-B / TAIYO YUDEN

When selecting capacitors for CIN and COUT, special care should be taken for rated voltage. The desirable rated voltage is about double the voltage actually applied to the capacitor. When the margin for rated voltage is not sufficient, the capacitance may be a half or less of the nominal value.

D1: Schottky barrier diode (SBD) for output rectification. To achieve high conversion efficiency, use a diode characterized by of low Vf, low reverse leak and high current capacity.

<Recommended parts>

Model number/manufacturer
RB160M-40 / ROHM

●Recommended PCB layout

When a PCB designed, the power supply line should be wired in a way that the board impedance can be minimized. If necessary, the bypass capacitor must be connected. In particular, pins around the DC/DC converter must be wired in such a way that the wiring impedance can be minimized. In addition, when a DC/DC converter using a coil is used, it is necessary to place the output capacitor COUT, coil L1, rectification diode D1 and bypass capacitor CIN near this IC and keep the GND impedance low.

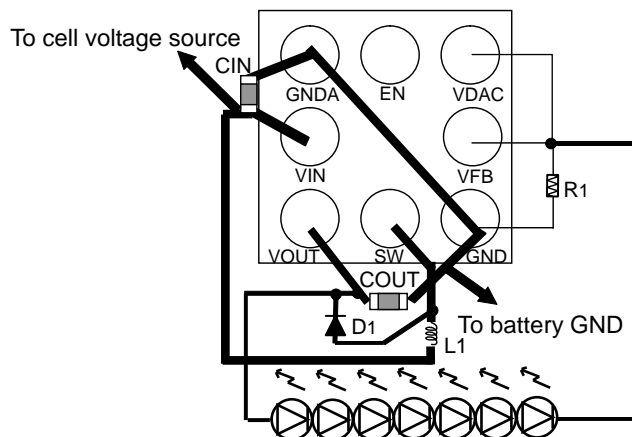
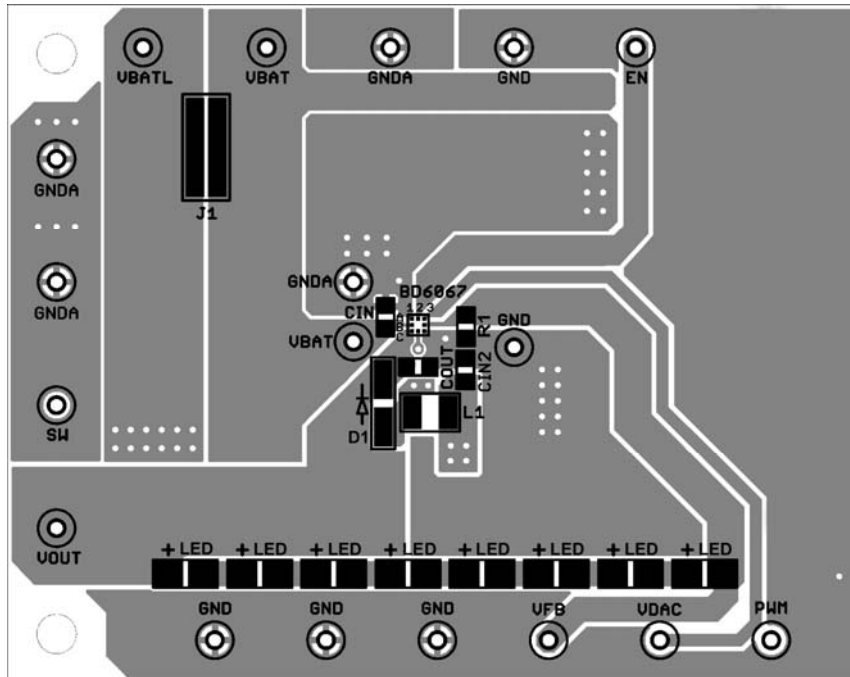
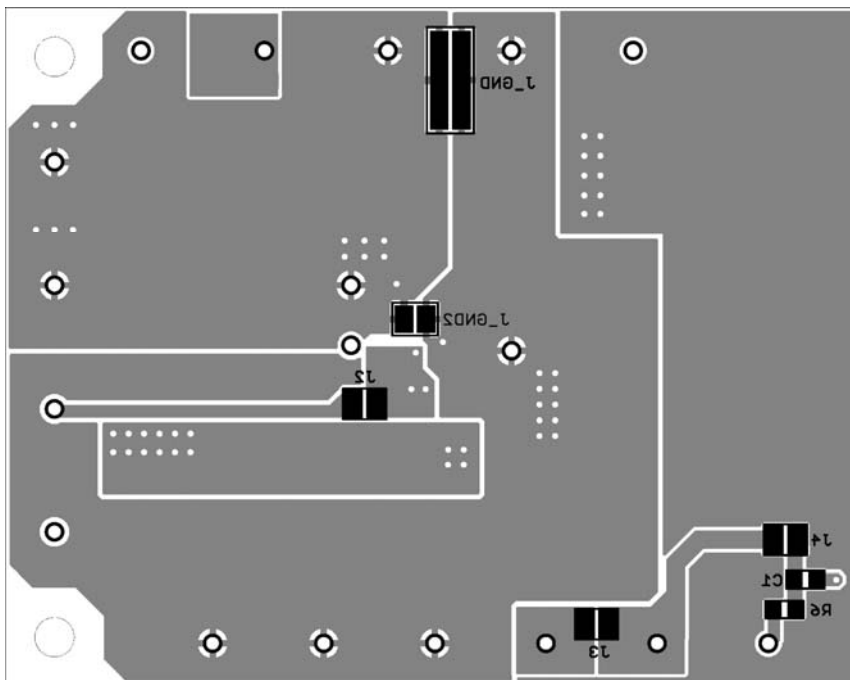

Figure 18. PCB Layout Image



Top surface (Top view)



Bottom surface (Top view)
Figure 19. PCB Layout

***Bypass capacitor and GND

It is necessary to place bypass capacitor CIN, coil L1 and power ground GND near this IC (CIN2 of Figure 19). To obtain good characteristics, as the need arises power supply, bypass capacitor CIN between analog GNDA must be added. (at LED8 lights). When LED has 8 lights, full assessment is required for characteristics prior to usage.

●Operational Notes

- 1) Absolute Maximum Ratings
An excess in the absolute maximum ratings, such as supply voltage, temperature range of operating conditions, etc., can break down devices, thus making impossible to identify breaking mode such as a short circuit or an open circuit. If any special mode exceeding the absolute maximum ratings is assumed, consideration should be given to take physical safety measures including the use of fuses, etc.
- 2) Operating conditions
These conditions represent a range within which characteristics can be provided approximately as expected. The electrical characteristics are guaranteed under the conditions of each parameter.
- 3) Reverse connection of power supply connector
The reverse connection of power supply connector can break down ICs. Take protective measures against the breakdown due to the reverse connection, such as mounting an external diode between the power supply and the IC's power supply terminal.
- 4) Power supply line
Design PCB pattern to provide low impedance for the wiring between the power supply and the GND lines. In this regard, for the digital block power supply and the analog block power supply, even though these power supplies has the same level of potential, separate the power supply pattern for the digital block from that for the analog block, thus suppressing the diffraction of digital noises to the analog block power supply resulting from impedance common to the wiring patterns. For the GND line, give consideration to design the patterns in a similar manner. Furthermore, for all power supply terminals to ICs, mount a capacitor between the power supply and the GND terminal. At the same time, in order to use an electrolytic capacitor, thoroughly check to be sure the characteristics of the capacitor to be used present no problem including the occurrence of capacity dropout at a low temperature, thus determining the constant.
- 5) GND voltage
Make setting of the potential of the GND terminal so that it will be maintained at the minimum in any operating state. Furthermore, check to be sure no terminals are at a potential lower than the GND voltage including an actual electric transient.
- 6) Short circuit between terminals and erroneous mounting
In order to mount ICs on a set PCB, pay thorough attention to the direction and offset of the ICs. Erroneous mounting can break down the ICs. Furthermore, if a short circuit occurs due to foreign matters entering between terminals or between the terminal and the power supply or the GND terminal, the ICs can break down.
- 7) Operation in strong electromagnetic field
Be noted that using ICs in the strong electromagnetic field can malfunction them.
- 8) Inspection with set PCB
On the inspection with the set PCB, if a capacitor is connected to a low-impedance IC terminal, the IC can suffer stress. Therefore, be sure to discharge from the set PCB by each process. Furthermore, in order to mount or dismount the set PCB to/from the jig for the inspection process, be sure to turn OFF the power supply and then mount the set PCB to the jig. After the completion of the inspection, be sure to turn OFF the power supply and then dismount it from the jig. In addition, for protection against static electricity, establish a ground for the assembly process and pay thorough attention to the transportation and the storage of the set PCB.
- 9) Input terminals
In terms of the construction of IC, parasitic elements are inevitably formed in relation to potential. The operation of the parasitic element can cause interference with circuit operation, thus resulting in a malfunction and then breakdown of the input terminal. Therefore, pay thorough attention not to handle the input terminals, such as to apply to the input terminals a voltage lower than the GND respectively, so that any parasitic element will operate. Furthermore, do not apply a voltage to the input terminals when no power supply voltage is applied to the IC. In addition, even if the power supply voltage is applied, apply to the input terminals a voltage lower than the power supply voltage or within the guaranteed value of electrical characteristics.
- 10) Ground wiring pattern
If small-signal GND and large-current GND are provided, It will be recommended to separate the large-current GND pattern from the small-signal GND pattern and establish a single ground at the reference point of the set PCB so that resistance to the wiring pattern and voltage fluctuations due to a large current will cause no fluctuations in voltages of the small-signal GND. Pay attention not to cause fluctuations in the GND wiring pattern of external parts as well.
- 11) External capacitor
In order to use a ceramic capacitor as the external capacitor, determine the constant with consideration given to a degradation in the nominal capacitance due to DC bias and changes in the capacitance due to temperature, etc.
- 12) Thermal shutdown circuit (TSD)
When junction temperatures become 175°C (Typ.) or higher, the thermal shutdown circuit operates and turns a switch OFF. The thermal shutdown circuit, which is aimed at isolating the LSI from thermal runaway as much as possible, is not aimed at the protection or guarantee of the LSI. Therefore, do not continuously use the LSI with this circuit operating or use the LSI assuming its operation.
- 13) Thermal design
Perform thermal design in which there are adequate margins by taking into account the permissible dissipation (Pd) in actual states of use.
- 14) Selection of coil
Select the low DCR inductors to decrease power loss for DC/DC converter.

Status of this document

The Japanese version of this document is formal specification. A customer may use this translation version only for a reference to help reading the formal version.

If there are any differences in translation version of this document formal version takes priority.

●Ordering Information

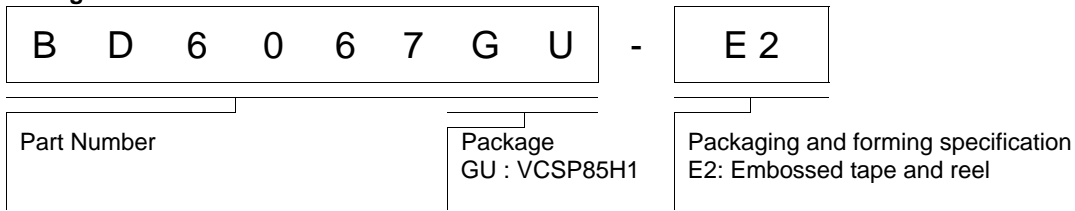

●Marking Diagram

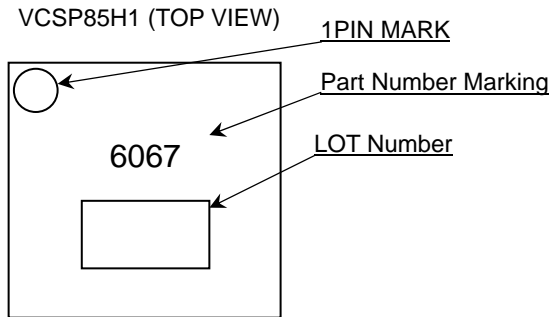

●Physical Dimension Tape and Reel Information

VCSP85H1 (BD6067GU)

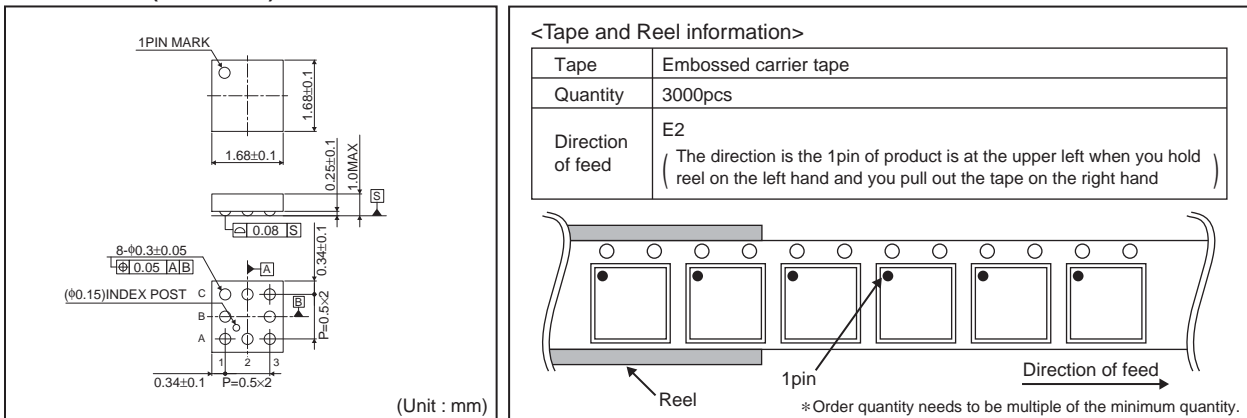

●Revision History

Date	Revision	Changes
05.Oct.2012	001	New Release

Notice

Precaution on using ROHM Products

- Our Products are designed and manufactured for application in ordinary electronic equipments (such as AV equipment, OA equipment, telecommunication equipment, home electronic appliances, amusement equipment, etc.). If you intend to use our Products in devices requiring extremely high reliability (such as medical equipment ^(Note 1), transport equipment, traffic equipment, aircraft/spacecraft, nuclear power controllers, fuel controllers, car equipment including car accessories, safety devices, etc.) and whose malfunction or failure may cause loss of human life, bodily injury or serious damage to property ("Specific Applications"), please consult with the ROHM sales representative in advance. Unless otherwise agreed in writing by ROHM in advance, ROHM shall not be in any way responsible or liable for any damages, expenses or losses incurred by you or third parties arising from the use of any ROHM's Products for Specific Applications.

(Note1) Medical Equipment Classification of the Specific Applications

JAPAN	USA	EU	CHINA
CLASS III	CLASS III	CLASS II b	CLASS III
CLASS IV		CLASS III	

- ROHM designs and manufactures its Products subject to strict quality control system. However, semiconductor products can fail or malfunction at a certain rate. Please be sure to implement, at your own responsibilities, adequate safety measures including but not limited to fail-safe design against the physical injury, damage to any property, which a failure or malfunction of our Products may cause. The following are examples of safety measures:
 - Installation of protection circuits or other protective devices to improve system safety
 - Installation of redundant circuits to reduce the impact of single or multiple circuit failure
- Our Products are designed and manufactured for use under standard conditions and not under any special or extraordinary environments or conditions, as exemplified below. Accordingly, ROHM shall not be in any way responsible or liable for any damages, expenses or losses arising from the use of any ROHM's Products under any special or extraordinary environments or conditions. If you intend to use our Products under any special or extraordinary environments or conditions (as exemplified below), your independent verification and confirmation of product performance, reliability, etc. prior to use, must be necessary:
 - Use of our Products in any types of liquid, including water, oils, chemicals, and organic solvents
 - Use of our Products outdoors or in places where the Products are exposed to direct sunlight or dust
 - Use of our Products in places where the Products are exposed to sea wind or corrosive gases, including Cl₂, H₂S, NH₃, SO₂, and NO₂
 - Use of our Products in places where the Products are exposed to static electricity or electromagnetic waves
 - Use of our Products in proximity to heat-producing components, plastic cords, or other flammable items
 - Sealing or coating our Products with resin or other coating materials
 - Use of our Products without cleaning residue of flux (even if you use no-clean type fluxes, cleaning residue of flux is recommended); or Washing our Products by using water or water-soluble cleaning agents for cleaning residue after soldering
 - Use of the Products in places subject to dew condensation
- The Products are not subject to radiation-proof design.
- Please verify and confirm characteristics of the final or mounted products in using the Products.
- In particular, if a transient load (a large amount of load applied in a short period of time, such as pulse. is applied, confirmation of performance characteristics after on-board mounting is strongly recommended. Avoid applying power exceeding normal rated power; exceeding the power rating under steady-state loading condition may negatively affect product performance and reliability.
- De-rate Power Dissipation (Pd) depending on Ambient temperature (Ta). When used in sealed area, confirm the actual ambient temperature.
- Confirm that operation temperature is within the specified range described in the product specification.
- ROHM shall not be in any way responsible or liable for failure induced under deviant condition from what is defined in this document.

Precaution for Mounting / Circuit board design

- When a highly active halogenous (chlorine, bromine, etc.) flux is used, the residue of flux may negatively affect product performance and reliability.
- In principle, the reflow soldering method must be used; if flow soldering method is preferred, please consult with the ROHM representative in advance.

For details, please refer to ROHM Mounting specification

Precautions Regarding Application Examples and External Circuits

1. If change is made to the constant of an external circuit, please allow a sufficient margin considering variations of the characteristics of the Products and external components, including transient characteristics, as well as static characteristics.
2. You agree that application notes, reference designs, and associated data and information contained in this document are presented only as guidance for Products use. Therefore, in case you use such information, you are solely responsible for it and you must exercise your own independent verification and judgment in the use of such information contained in this document. ROHM shall not be in any way responsible or liable for any damages, expenses or losses incurred by you or third parties arising from the use of such information.

Precaution for Electrostatic

This Product is electrostatic sensitive product, which may be damaged due to electrostatic discharge. Please take proper caution in your manufacturing process and storage so that voltage exceeding the Products maximum rating will not be applied to Products. Please take special care under dry condition (e.g. Grounding of human body / equipment / solder iron, isolation from charged objects, setting of ionizer, friction prevention and temperature / humidity control).

Precaution for Storage / Transportation

1. Product performance and soldered connections may deteriorate if the Products are stored in the places where:
 - [a] the Products are exposed to sea winds or corrosive gases, including Cl₂, H₂S, NH₃, SO₂, and NO₂
 - [b] the temperature or humidity exceeds those recommended by ROHM
 - [c] the Products are exposed to direct sunshine or condensation
 - [d] the Products are exposed to high Electrostatic
2. Even under ROHM recommended storage condition, solderability of products out of recommended storage time period may be degraded. It is strongly recommended to confirm solderability before using Products of which storage time is exceeding the recommended storage time period.
3. Store / transport cartons in the correct direction, which is indicated on a carton with a symbol. Otherwise bent leads may occur due to excessive stress applied when dropping of a carton.
4. Use Products within the specified time after opening a humidity barrier bag. Baking is required before using Products of which storage time is exceeding the recommended storage time period.

Precaution for Product Label

QR code printed on ROHM Products label is for ROHM's internal use only.

Precaution for Disposition

When disposing Products please dispose them properly using an authorized industry waste company.

Precaution for Foreign Exchange and Foreign Trade act

Since our Products might fall under controlled goods prescribed by the applicable foreign exchange and foreign trade act, please consult with ROHM representative in case of export.

Precaution Regarding Intellectual Property Rights

1. All information and data including but not limited to application example contained in this document is for reference only. ROHM does not warrant that foregoing information or data will not infringe any intellectual property rights or any other rights of any third party regarding such information or data. ROHM shall not be in any way responsible or liable for infringement of any intellectual property rights or other damages arising from use of such information or data.:
2. No license, expressly or implied, is granted hereby under any intellectual property rights or other rights of ROHM or any third parties with respect to the information contained in this document.

Other Precaution



1. This document may not be reprinted or reproduced, in whole or in part, without prior written consent of ROHM.
2. The Products may not be disassembled, converted, modified, reproduced or otherwise changed without prior written consent of ROHM.
3. In no event shall you use in any way whatsoever the Products and the related technical information contained in the Products or this document for any military purposes, including but not limited to, the development of mass-destruction weapons.
4. The proper names of companies or products described in this document are trademarks or registered trademarks of ROHM, its affiliated companies or third parties.

General Precaution

1. Before you use our Products, you are requested to carefully read this document and fully understand its contents. ROHM shall not be in any way responsible or liable for failure, malfunction or accident arising from the use of any ROHM's Products against warning, caution or note contained in this document.
2. All information contained in this document is current as of the issuing date and subject to change without any prior notice. Before purchasing or using ROHM's Products, please confirm the latest information with a ROHM sales representative.
3. The information contained in this document is provided on an "as is" basis and ROHM does not warrant that all information contained in this document is accurate and/or error-free. ROHM shall not be in any way responsible or liable for any damages, expenses or losses incurred by you or third parties resulting from inaccuracy or errors of or concerning such information.

Looking for pricing, stock, or lifecycle information?

Click below to explore more details on WIN SOURCE:

-  [View BD6067GU-E2 on WIN SOURCE](#)
-  [Rohm Semiconductor](#) Information

Optimize Your Supply Chain with WIN SOURCE Solutions

-  Global Sourcing Solution
-  Obsolete Management
-  Cost Control Management
-  Shortage Management
-  Alternative Solution
-  Excess Inventory Management