



**THE DATASHEET OF
ISL55143IRZ**



ISL55141, ISL55142, ISL55143

High-Speed 18V CMOS Comparators

FN6230
Rev 4.00
August 13, 2015

ISL55141, ISL55142, ISL55143 integrated circuits are high-speed, wide input common-mode range comparators. They provide three-state window comparators in a high voltage CMOS process (18V). Each comparator has dual receive thresholds, CV_A and CV_B , for establishing minimum $1-V_{IH}$ and maximum $0-V_{IL}$ voltage levels. These devices can accept inputs from a number of logic families, such as TTL, ECL, CMOS, LVCMOS, LVDS and CML. Two bits of output per comparator provide the test controller with qualification of a comparator input into three states. The two output bits work with a separate user supply to establish V_{OH} , V_{OL} levels compatibility with the system's controller logic levels.

Fast propagation delay (9.5ns typical at $\pm 50mV$ overdrive) makes this family compatible with high-speed digital test systems. The 18V range enables the comparator input to operate over a wide input range. Two references per input enable and three state digitalization of input with voltage swings of up to 13V common mode. The operating frequency of these devices is typically 65MHz.

High voltage CMOS process makes these devices ideal for large voltage swing applications, such as special test voltages levels associated with Flash devices or power supervision applications and may avoid the need for test bus isolation relay(s).

Features

- 18V I/O Range
- 65MHz Operation
- 9.5ns Typical Propagation Delay
- Programmable Input Thresholds
- User Defined Comparator Output Levels
- Common-Mode Range Includes Negative Rails
- Small Footprints in QFN Packages
- Power-Down Current $<10\mu A$
- Pb-Free (RoHS compliant)

Applications

- Burn in ATE
- Low Cost ATE
- Fast Supervisory Power Control
- Instrumentation

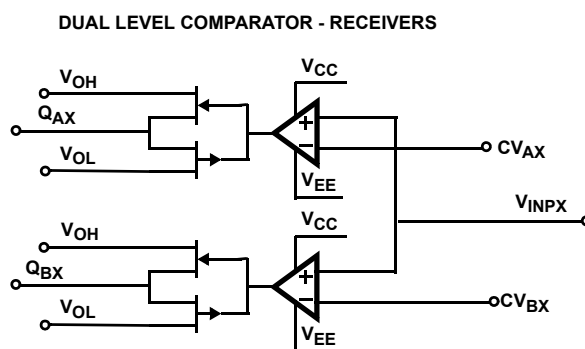

Note: x denotes 1, 2 or 4 channels for ISL55141, ISL55142 and ISL55143, respectively

FIGURE 1. FUNCTIONAL BLOCK DIAGRAM

Pinouts

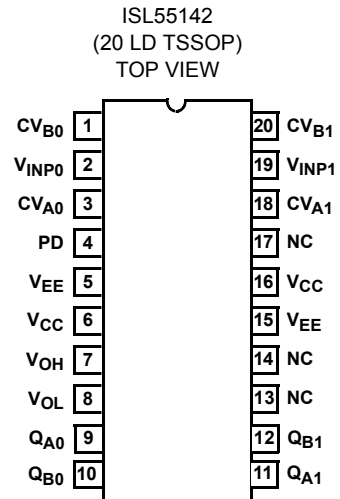
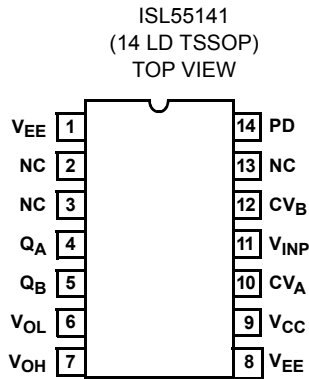
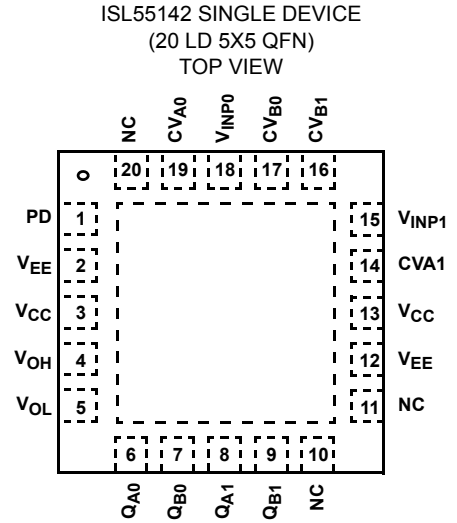
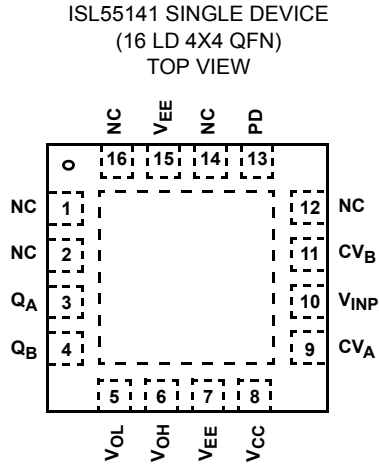

ISL55143 QUAD DEVICE
(36 LD 6X6 TQFN)
TOP VIEW

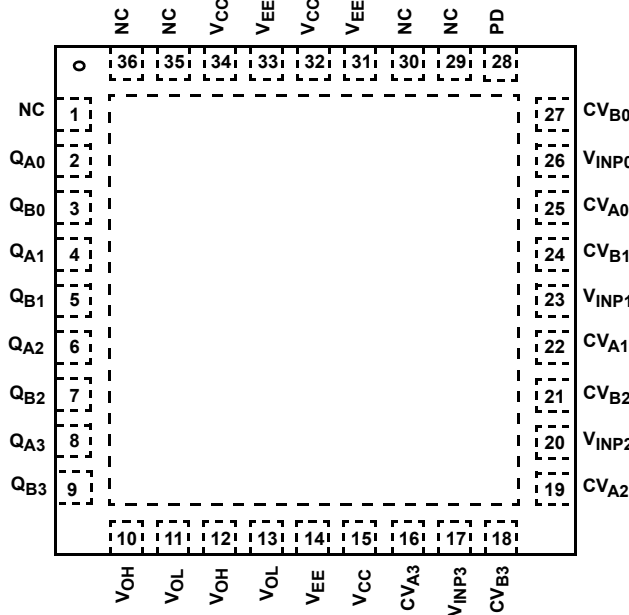

Pin Descriptions

PIN	FUNCTION
V _{EE}	Negative supply input
Q _{AX}	Channel A, CV _{AX} reference driven. Comparator output.
Q _{BX}	Channel B, CV _{BX} reference driven. Comparator output.
V _{OL}	Comparator output logic low supply. Unbuffered analog input that sets all Q _{AX} , Q _{BX} "low" voltage level.
V _{OH}	Comparator output logic high supply. Unbuffered analog input that sets all Q _{AX} , Q _{BX} "high" voltage level.
V _{CC}	Positive supply input.
CV _{AX}	Channel A comparator reference analog input.
V _{INPX}	Window comparator input. Common to both Channel Ax and Channel Bx.
CV _{BX}	Channel B comparator reference analog input.
PD	Power-down logic input (connect to V _{EE} if not used for power-down).
NC	No internal connection.

TABLE 1. CV_A-Q_A AND CV_B-Q_B BASIC COMPARATOR TRUTH TABLE

INPUT		OUTPUTS*	
V _{INPX}		Q _{AX}	Q _{BX}
<CV _{AX}	<CV _{BX}	0	0
<CV _{AX}	>CV _{BX}	0	1
>CV _{AX}	<CV _{BX}	1	0
>CV _{AX}	>CV _{BX}	1	1
* When Q _{AX} /Q _{BX} = 1, Output is connect to V _{OH}			
* When Q _{AX} /Q _{BX} = 0, Output is connect to V _{OL}			

Ordering Information

PART NUMBER (Notes 1, 2, 3)	PART MARKING	TEMP. RANGE (°C)	PACKAGE (Pb-Free)	PKG. DWG. #
ISL55141IRZ (No longer available or supported)	55 141IRZ	-40 to +85	16 Ld QFN	L16.4X4A
ISL55141IVZ (No longer available or supported)	55141 IVZ	-40 to +85	14 Ld TSSOP	M14.173
ISL55142IRZ (No longer available or supported)	55142 IRZ	-40 to +85	20 Ld QFN	L20.5x5
ISL55142IVZ (No longer available or supported)	55142 IVZ	-40 to +85	20 Ld TSSOP	M20.173
ISL55143IRZ	55143 IRZ	-40 to +85	36 Ld TQFN	L36.6X6

NOTES:

- Add "-T*" suffix for tape and reel. Please refer to [TB347](#) for details on reel specifications.
- These Intersil Pb-free plastic packaged products employ special Pb-free material sets, molding compounds/die attach materials, and 100% matte tin plate plus anneal (e3 termination finish, which is RoHS compliant and compatible with both SnPb and Pb-free soldering operations). Intersil Pb-free products are MSL classified at Pb-free peak reflow temperatures that meet or exceed the Pb-free requirements of IPC/JEDEC J STD-020.
- For Moisture Sensitivity Level (MSL), please see device information page for [ISL55141](#), [ISL55142](#), [ISL55143](#). For more information on MSL please see techbrief TB363.

Absolute Maximum Ratings

V_{CC} to V_{EE}	-0.5V to 19V
Input Voltages PD, CV_{AX} , CV_{BX} , V_{INPX} , V_{OH} , V_{OL}	(V_{EE} -0.5V) to (V_{CC} +0.5V)
Output Voltage Q_{AX} , Q_{BX}	(V_{OL} -0.5V) to (V_{OH} +0.5V)

Thermal Information

Thermal Resistance (Typical, Note 8)	θ_{JA} (°C/W)	θ_{JC} (°C/W)
16 Ld QFN Package (Notes 6, 7)	40	3
14 Ld TSSOP Package (Notes 4, 5)	100	31
20 Ld QFN Package (Notes 6, 7)	31	1.4
20 Ld TSSOP Package (Notes 4, 5)	76	25
36 Ld TQFN Package (Notes 6, 7)	29	0.75
Maximum Junction Temperature (Plastic Package)	150°	
Maximum Storage Temperature	-65°C to 150°C	
Pb-Free Reflow Profile.	see link below http://www.intersil.com/pbfree/Pb-FreeReflow.asp	

CAUTION: Do not operate at or near the maximum ratings listed for extended periods of time. Exposure to such conditions may adversely impact product reliability and result in failures not covered by warranty.

NOTES:

- θ_{JA} is measured with the component mounted on a high effective thermal conductivity test board in free air. See Tech Brief TB379 for details.
- For θ_{JC} , the "case temp" location is taken at the package top center.
- θ_{JA} is measured in free air with the component mounted on a high effective thermal conductivity test board with "direct attach" features. See Tech Brief TB379.
- For θ_{JC} , the "case temp" location is the center of the exposed metal pad on the package underside.
- Device temperature is closely tied to data-rates, driver loads and overall pin activity. Review "Power Dissipation Considerations" on page 6 for more information.

Recommended Operating Conditions

PARAMETER	SYMBOL	MIN	TYP	MAX	UNITS
Device Power	V_{CC} - V_{EE}	10	15	18	V
Comparator Output High Rail	V_{OH}	$V_{EE}+1$		$V_{CC}-0.5$	V
Comparator Output Low Rail	V_{OL}	$V_{EE}+0.5$		$V_{EE}+6$	V
Common Mode Input Voltage Range	V_{CM}	V_{EE}		$V_{CC}-5$	V
Ambient Temperature	T_A	-40	27	+85	°C
Junction Temperature	T_J			+125	°C

Electrical Specifications Test Conditions: $V_{CC} = 12V$, $V_{EE} = -3V$, $V_{OH} = 5V$, $V_{OL} = 0V$, $PD = V_{EE}$, $C_{LOAD} = 15pF$, $T_A = 25^\circ C$, unless otherwise specified.

PARAMETER	SYMBOL	TEST CONDITIONS	MIN (Note 13)	TYP	MAX (Note 13)	UNITS
DC CHARACTERISTICS						
Input Offset Voltage	V_{OS}	$CV_{AX} = CV_{BX} = 1.5V$	-50		50	mV
Input Bias Current	I_{BIAS}	$V_{INPX} - CV_{(A/B)X} = \pm 5V$		10	25	nA
Power-down Current	I_{PD}	$PD = V_{CC}$		8	25	μA
Power-down Time (Note 11)	t_{PD}			10		μs
Power-up Time (Note 11)	t_{PU}			15		μs
TIMING CHARACTERISTICS						
Propagation Delay	t_{pd}		4.0	9.5	15	ns
Rise Time (Note 11)	t_r			1.4		ns
Fall Time (Note 11)	t_f			1.5		ns
Propagation Delay Mismatch	Δt_{pd}			0.5	2	ns
Maximum Operating Frequency	F_{MAXR}	Symmetry 50%		65		MHz
Min Pulse Width	t_{WIDR}			7.7		ns
COMPARATOR INPUT						
Input Current	I_{IN}	$V_{INPX} = V_{CC}$ or V_{EE}	-100	0	100	nA

Electrical Specifications Test Conditions: $V_{CC} = 12V$, $V_{EE} = -3V$, $V_{OH} = 5V$, $V_{OL} = 0V$, $P_D = V_{EE}$, $C_{LOAD} = 15pF$, $T_A = 25^\circ C$, unless otherwise specified. **(Continued)**

PARAMETER	SYMBOL	TEST CONDITIONS	MIN (Note 13)	TYP	MAX (Note 13)	UNITS
Input Capacitance (Note 11)	C_{IN}			2.5		pF
DIGITAL OUTPUTS Q_{AX}, Q_{BX}						
Output Resistance	R_{outR}		18	27	37	Ω
Output Logic High Voltage	V_{OH}	$V_{OH} = 5V$, $I_{SOURCE} = 1mA$	4.9	4.95	5.0	V
Output Logic Low Voltage	V_{OL}	$V_{OL} = 0V$, $I_{SINK} = 1mA$	0.00	0.05	0.1	V
POWER SUPPLIES, STATIC CONDITIONS						
Positive Supply DC Current/Comparator	I_{CC}	No input data		+8.25	12.5	mA
Negative Supply Current/Comparator	I_{EE}	No input data	-12.5	-8.25		mA
Total Power Dissipation/Comparator	P (Note 12)	Input data at 40MHz		670		mW

NOTES:

- Lab characterization, room temperature, timing parameters matched stimulus/loads, channel-to-channel skew < 500ps, 1ns maximum by design
- Note about I_{CC} measurement input can approach 140mA (single comparator) at maximum pattern rates
- Limits should be considered typical and are not production tested.
- Total Power dissipation per comparator can be approximately calculated from the following:
 $P = (V_{CC}-V_{EE}) * 8.25mW + 90pF * (V_{CC}-V_{EE})^2 * f + C_L * (V_{CC}-V_{EE})^2 * f$, where f is the operating frequency and C_L is the load capacitance.
 Because the ISL55142 has two comparators, the power dissipation would be twice of P calculated from this equation. The ISL55143 would be four times P.
- Compliance to datasheet limits is assured by one or more methods: production test, characterization and/or design.

Test Circuits and Waveforms

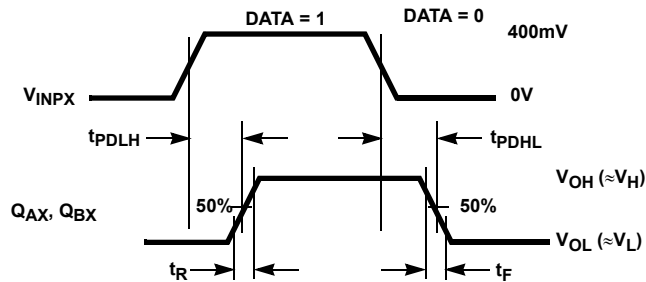

FIGURE 2. COMPARATOR PROPAGATION DELAY AND TRANSITION TIME MEASUREMENT POINTS

Although there is no electrical difference between the CV_A and CV_B Inputs, if one defines CV_A as being the high threshold and CV_B being the low threshold, it becomes easier to understand the utilization of a dual threshold comparator. Essentially this enables the qualification of an incoming signal into three states. In Figure 3, the three states are Valid Low <0.4V, No-man's-land (between 0.4 and 2.4V), Valid High >2.4V. Table 2 shows how the Q_A/Q_B truth table would be utilized in the real world.

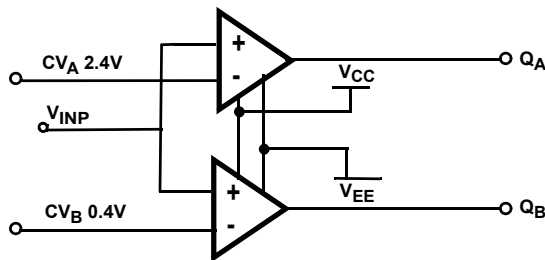
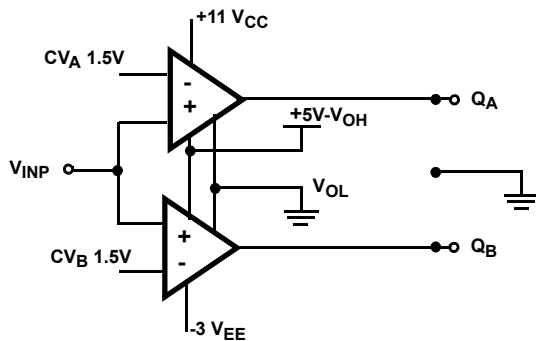

TABLE 2. Q_A/Q_B TRUTH TABLE

V_{INP}	Q_A	Q_B	COMMENT
<0.4V	0	0	Valid 0
>0.4 and <2.4V	0	1	Invalid
>2.4V	1	1	Valid 1

FIGURE 3. THREE-STATE WINDOW COMPARATOR FUNDAMENTALS

Test Circuits and Waveforms (Continued)FIGURE 4. t_{PD} RECEIVER SWITCHING TEST CIRCUIT**Application Information**

The ISL55141, ISL55142, ISL55143 provide 1, 2 and 4 dual threshold, three-state window comparator(s) in TSSOP or QFN footprints. They offer a combination of speed (10ns T_{pd} and wide voltage range (18V). This product directly addresses the need for unique common-mode characteristics while supplying a power-down feature.

Figures 4 and 5 show the stimulus setup and measurement points for an example propagation delay measurement. Typical room temperature results are displayed in Figure 12.

Figure 5 shows a V_{INP} range of 50mV. In Figure 12 the offset is increased in the horizontal axis from 50mV above and below the reference (1.5V) up to 2.5V above and below the 1.5V reference.

Two lines are displayed in Figure 12. One represents the rising-to-rising delay (t_{PDLH}) and the other the falling-to-falling delay (t_{PDHL}).

Comparator Features

These three-state window comparators feature high output current capability, and user defined high and low output levels to interface with a wide variety of logic families. Each receiver comprises two comparators and each comparator has an independent threshold level input, making it easy to implement (Minimum $1-V_{IH}$)/(Maximum $0-V_{IL}$) logic level comparator functions. The CV_{AX} and CV_{BX} pins set the threshold levels of the A and B comparators respectively. V_{OH} and V_{OL} set all the comparator output levels, and V_{OH} must be more positive than V_{OL} . These two inputs are unbuffered supply pins, so the sources driving these pins must provide adequate current for the expected load. V_{OH} and V_{OL} typically connect to the power supplies of the logic device driven by the comparator outputs.

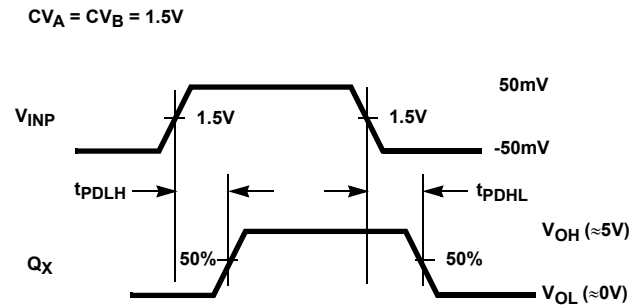
FIGURE 5. t_{PD} RECEIVER PROPAGATION DELAY MEASUREMENT POINTS

The truth table for the receivers is given in Table 1. Receiver outputs are not tri-statable, and do not incorporate any on-chip short circuit current protection. Momentary short circuits to GND, or any supply voltage, will not cause permanent damage, but care must be taken to avoid longer duration short circuits. If tolerable to the application, current limiting resistors can be inserted in series with the Q_{AX} and Q_{BX} outputs to protect the receiver outputs from damage due to overcurrent conditions.

Power-down Features

The ISL55141, ISL55142, ISL55143 PD pin provides a means of reducing current consumption when the device is not in use. Supply currents fall from ~ 7 mA to less than 10 μ A in the power-down mode. The device requires approximately 10 μ s to power-down and 15 μ s to power-up.

Power Supply Bypassing and Printed Circuit Board Layout

As with any high frequency device, good printed circuit board layout is necessary for optimum performance. Ground plane construction is highly recommended, lead lengths should be as short as possible, and the power supply pins must be well bypassed to reduce the risk of oscillation. For normal single supply operation, where the V_{EE} pin is connected to ground, one 0.1 μ F ceramic capacitor should be placed from the V_{CC} pin to ground. A 4.7 μ F tantalum capacitor should then be connected from the V_{CC} pin to ground. This same capacitor combination should be placed at each supply pin to ground if split supplies are to be used.

Power Dissipation Considerations

Specifying continuous data rates, driver loads and driver level amplitudes are key in determining power supply requirements as well as dissipation/cooling necessities. Driver output patterns also impact these needs. The faster the pin activity, the greater the need to supply current and remove heat.

The maximum power dissipation allowed in a package is determined according to Equation 1.

$$P_{D\text{MAX}} = \frac{T_{J\text{MAX}} - T_{A\text{MAX}}}{\theta_{JA}} \quad (\text{EQ. 1})$$

where:

- $T_{J\text{MAX}}$ = Maximum junction temperature
- $T_{A\text{MAX}}$ = Maximum ambient temperature
- θ_{JA} = Thermal resistance of the package
- $P_{D\text{MAX}}$ = Maximum power dissipation in the package

Approximate Power Dissipation

$$(Typ) P = N * [(V_{CC} - V_{EE}) * 8.25mW + 90pF * (V_{CC} - V_{EE})^2 * f + CL * (V_{OH} - V_{OL})^2 * f]$$

where:

- N is the number of comparators in the chip (1 for ISL55141, 2 for ISL55142 and 4 for ISL55143).
- (f) is the operating frequency.
- CL is the load capacitor.

The power dissipation calculated from the above formula may have an error of ±20 to 25%.

The maximum power dissipation actually produced by an IC is the total quiescent supply current times the total power supply voltage, plus the power in the IC due to the loads. Power also depends on the number of channels changing state and frequency of operation. The extent of continuous active pattern generation/reception will greatly affect dissipation requirements.

The user should evaluate various heat sink/cooling options in order to control the ambient temperature part of the equation. This is especially true if the user's applications require continuous, high-speed operation.

Note: The reader is cautioned against assuming the same level of thermal performance in actual applications. A careful inspection of conditions in your application should be conducted.

Power Supply Information

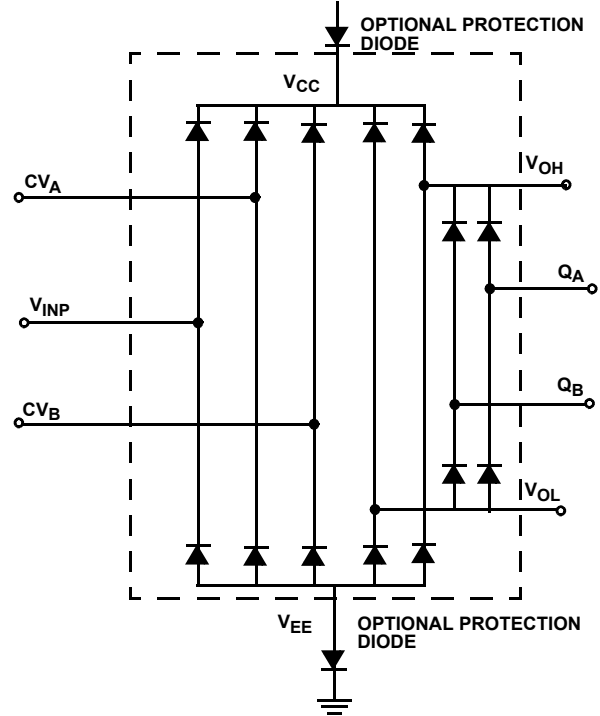

Circuit design must always take into account the internal EOS/ESD protection structure of the device.

Important Note: The QFN package metal plane is used for heat sinking of the device. It is electrically connected to the negative supply potential (VEE). If VEE is tied to ground, the thermal pad can be connected to ground. Otherwise, the thermal pad (VEE) must be isolated from other power planes.

Power Supply Sequencing

The ISL55141, ISL55142, ISL55143 reference every supply with respect to VEE. Therefore, apply VEE, V_{OL} then V_{CC} followed by the CV_A and CV_B supplies. The comparator V_{INP} pin should not exceed VEE or V_{CC} during power-up.

In cases where inputs may exceed voltage rails during power-up, series resistance should be employed to safeguard EOS to the ESD protection diodes.

Typical Performance Curves Device installed on Intersil ISL55141, ISL55142, ISL55143 Evaluation Boards.

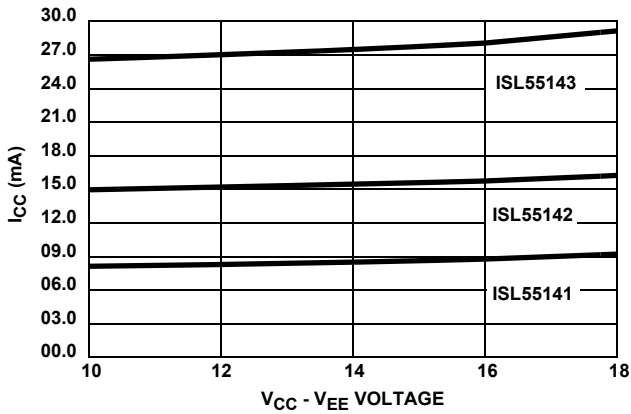

FIGURE 6. ISL55141, ISL55142, ISL55143 QUIESCENT CURRENT

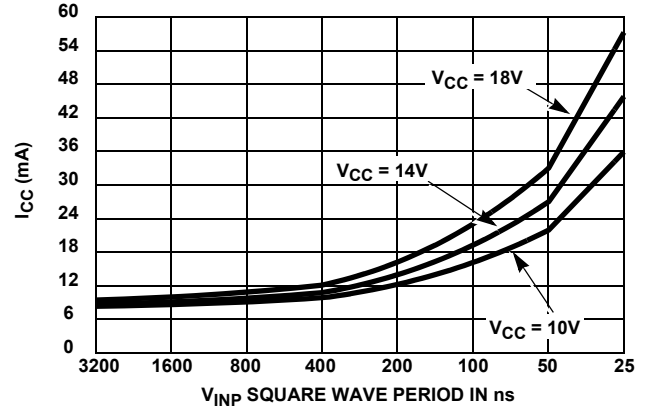

FIGURE 7. ISL55141 I_{CC} vs FREQUENCY @ 10V, 14V, AND 18V

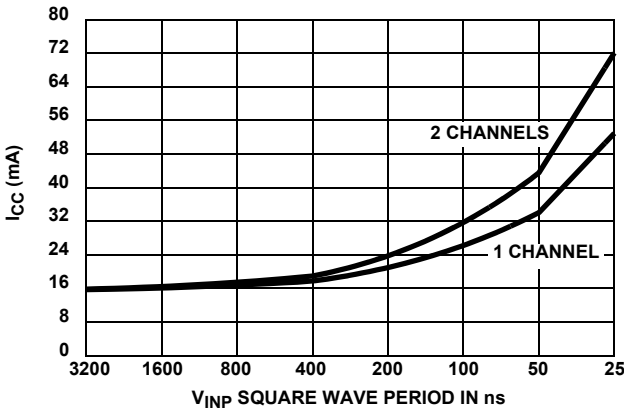

FIGURE 8. ISL55142 I_{CC} 1 AND 2 CHANNELS ACTIVE

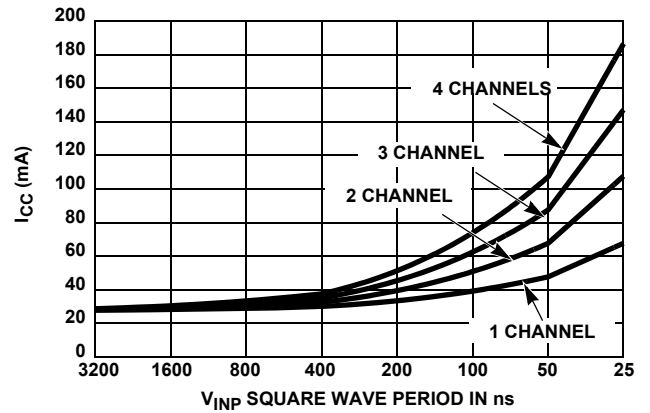

FIGURE 9. ISL55143 I_{CC} 1, 2, 3, 4 CHANNELS ACTIVE

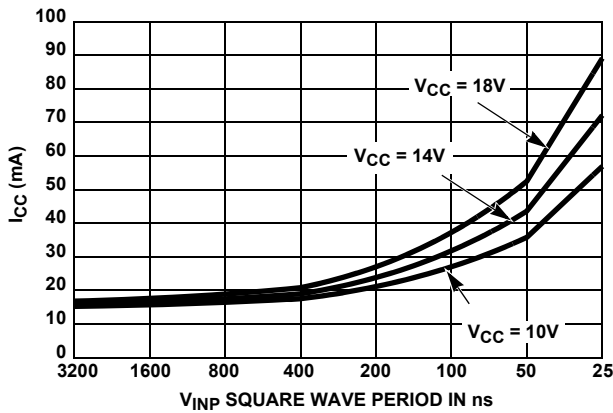

FIGURE 10. ISL55142 2-CHANNEL I_{CC} @ 10V, 14V, AND 18V

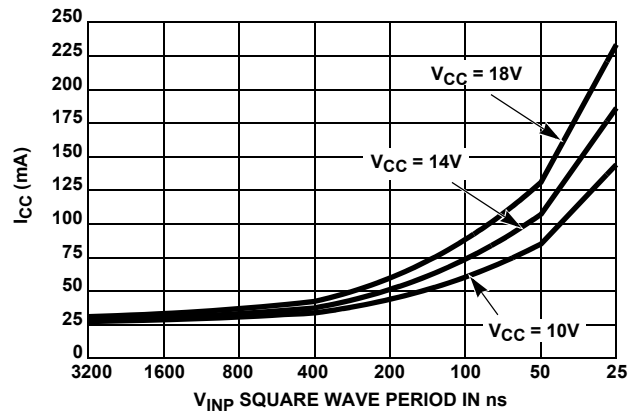

FIGURE 11. ISL55143 4-CHANNEL I_{CC} @ 10V, 14V, AND 18V

Typical Performance Curves Device installed on Intersil ISL55141, ISL55142, ISL55143 Evaluation Boards. (Continued)

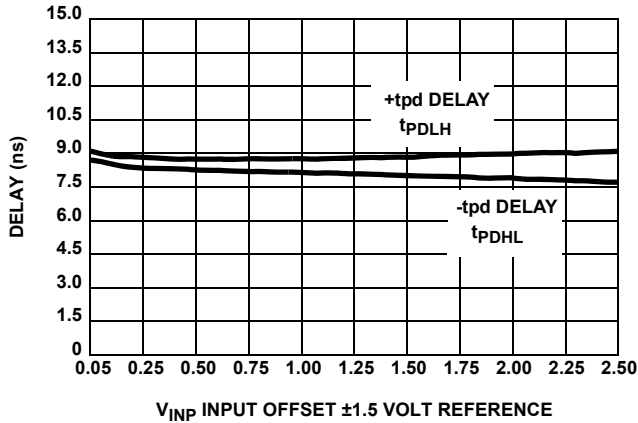

FIGURE 12. PROPAGATION DELAY @ 14V $V_{CC}-V_{EE}$

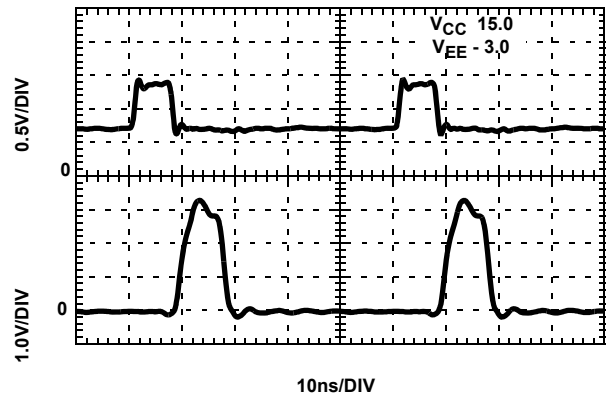

FIGURE 13. MINIMUM PULSE WIDTH RESPONSE

Revision History

The revision history provided is for informational purposes only and is believed to be accurate, but not warranted. Please go to the web to make sure that you have the latest revision.

DATE	REVISION	CHANGE
August 13, 2015	FN6230.4	Moved Ordering Information to page 3 and fixed page 1 layout. Updated Ordering Information table on page 3. Added Revision History and About Intersil sections. Updated Package Outline Drawing (POD) L16.4X4A to the latest revision changes are as follows: Updated to new POD format by removing table listing dimensions and moving dimensions onto drawing. Added Typical Recommended Land Pattern. Removed package option.

About Intersil

Intersil Corporation is a leading provider of innovative power management and precision analog solutions. The company's products address some of the largest markets within the industrial and infrastructure, mobile computing and high-end consumer markets.

For the most updated datasheet, application notes, related documentation and related parts, please see the respective product information page found at www.intersil.com.

You may report errors or suggestions for improving this datasheet by visiting www.intersil.com/ask.

Reliability reports are also available from our website at www.intersil.com/support

© Copyright Intersil Americas LLC 2006-2015. All Rights Reserved.
All trademarks and registered trademarks are the property of their respective owners.

For additional products, see www.intersil.com/en/products.html

Intersil products are manufactured, assembled and tested utilizing ISO9001 quality systems as noted in the quality certifications found at www.intersil.com/en/support/qualandreliability.html

Intersil products are sold by description only. Intersil may modify the circuit design and/or specifications of products at any time without notice, provided that such modification does not, in Intersil's sole judgment, affect the form, fit or function of the product. Accordingly, the reader is cautioned to verify that datasheets are current before placing orders. Information furnished by Intersil is believed to be accurate and reliable. However, no responsibility is assumed by Intersil or its subsidiaries for its use; nor for any infringements of patents or other rights of third parties which may result from its use. No license is granted by implication or otherwise under any patent or patent rights of Intersil or its subsidiaries.

For information regarding Intersil Corporation and its products, see www.intersil.com

Package Outline Drawing

L16.4x4A

16 LEAD QUAD FLAT NO-LEAD PLASTIC PACKAGE

Rev 3, 03/15

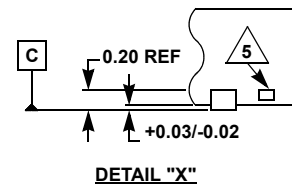
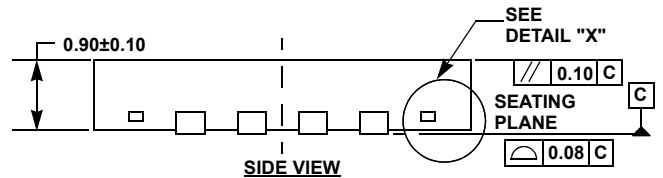
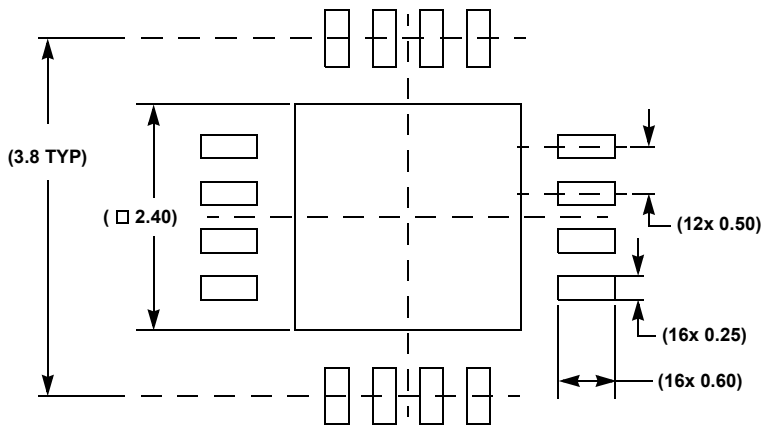
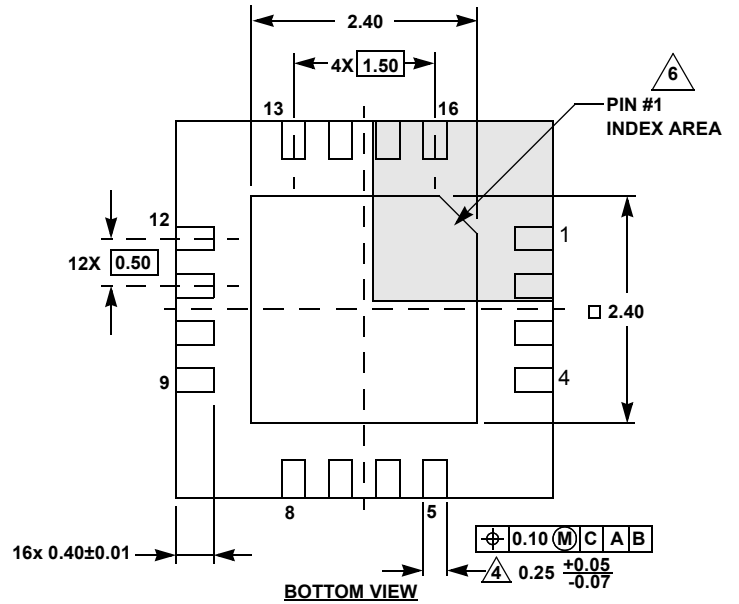
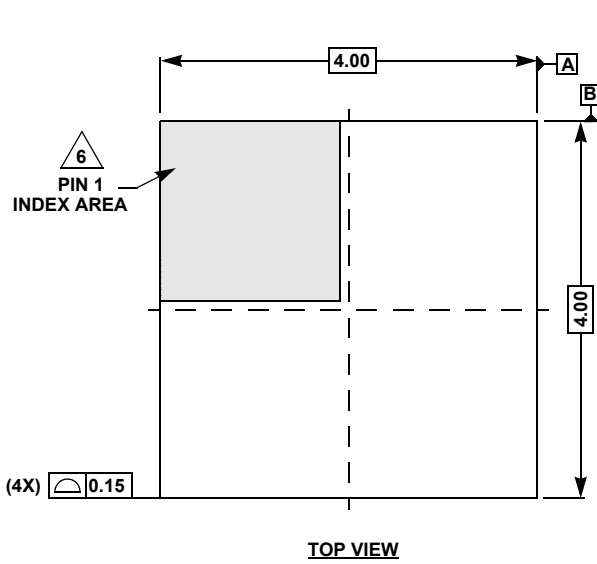

NOTES:

1. Dimensions are in millimeters.
Dimensions in () for Reference Only.
2. Dimensioning and tolerancing conform to ASME Y14.5m-1994.
3. Unless otherwise specified, tolerance: Decimal ± 0.05
4. Dimension applies to the metallized terminal and is measured between 0.15mm and 0.30mm from the terminal tip.
5. Tiebar shown (if present) is a non-functional feature.
6. The configuration of the pin #1 identifier is optional, but must be located within the zone indicated. The pin #1 identifier may be either a mold or mark feature.

Package Outline Drawing

M14.173

14 LEAD THIN SHRINK SMALL OUTLINE PACKAGE (TSSOP)

Rev 3, 10/09

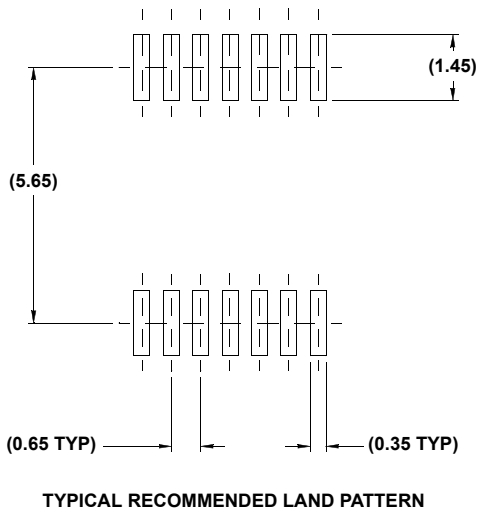
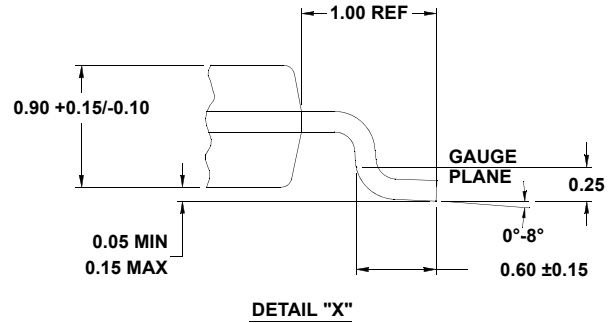
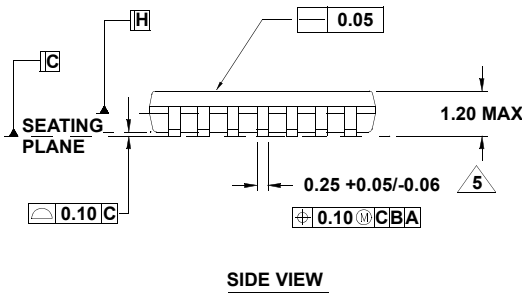
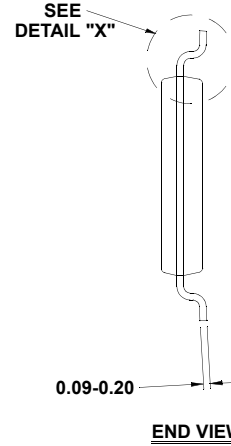
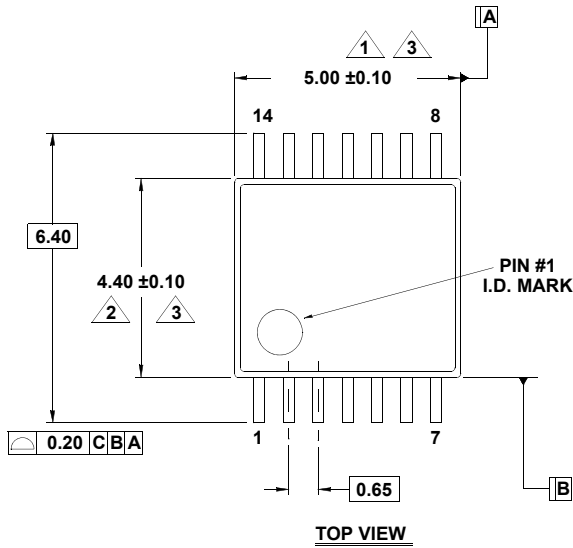

NOTES:

1. Dimension does not include mold flash, protrusions or gate burrs. Mold flash, protrusions or gate burrs shall not exceed 0.15 per side.
2. Dimension does not include interlead flash or protrusion. Interlead flash or protrusion shall not exceed 0.25 per side.
3. Dimensions are measured at datum plane H.
4. Dimensioning and tolerancing per ASME Y14.5M-1994.
5. Dimension does not include dambar protrusion. Allowable protrusion shall be 0.80mm total in excess of dimension at maximum material condition. Minimum space between protrusion and adjacent lead is 0.07mm.
6. Dimension in () are for reference only.
7. Conforms to JEDEC MO-153, variation AB-1.

**Quad Flat No-Lead Plastic Package (QFN)
Micro Lead Frame Plastic Package (MLFP)**

L20.5x5

20 LEAD QUAD FLAT NO-LEAD PLASTIC PACKAGE

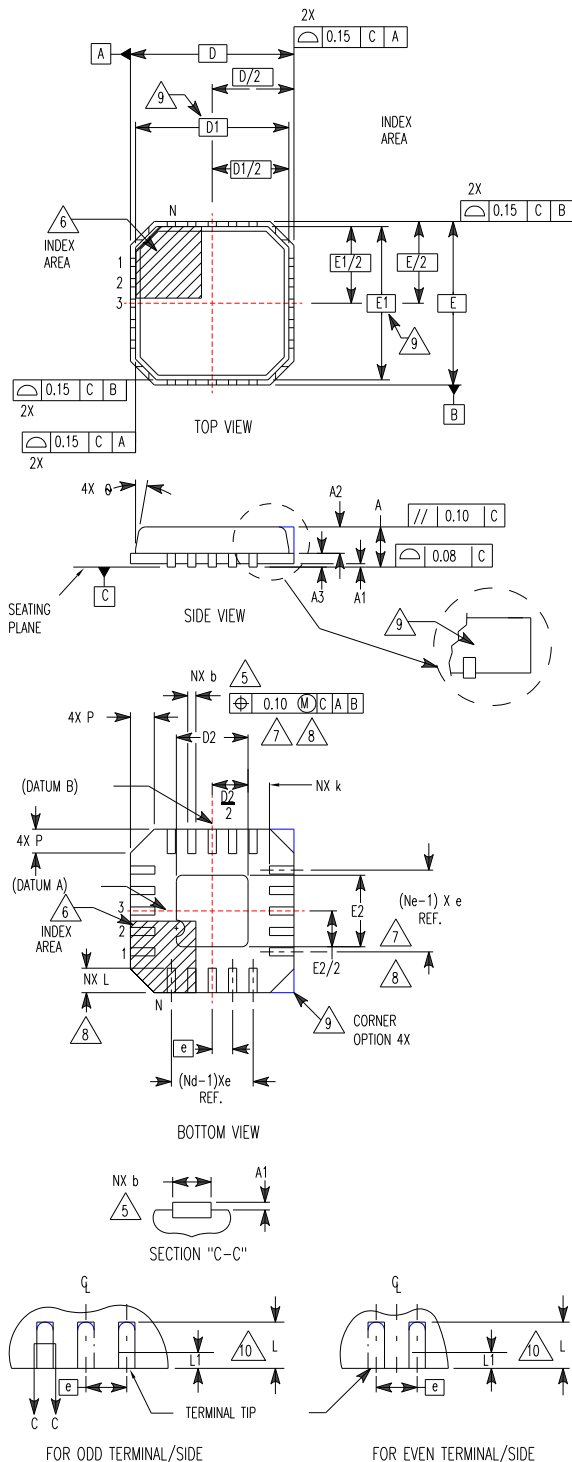

SYMBOL	MILLIMETERS			NOTES
	MIN	NOMINAL	MAX	
A	0.80	0.90	1.00	-
A1	-	0.02	0.05	-
A2	-	0.65	1.00	9
A3	0.20 REF			9
b	0.23	0.30	0.38	5, 8
D	5.00 BSC			-
D1	4.75 BSC			9
D2	2.95	3.10	3.25	7, 8
E	5.00 BSC			-
E1	4.75 BSC			9
E2	2.95	3.10	3.25	7, 8
e	0.65 BSC			-
k	0.20	-	-	-
L	0.35	0.60	0.75	8
N	20			2
Nd	5			3
Ne	5			3
P	-	-	0.60	9
theta	-	-	12	9

Rev. 4 11/04

NOTES:

1. Dimensioning and tolerancing conform to ASME Y14.5-1994.
2. N is the number of terminals.
3. Nd and Ne refer to the number of terminals on each D and E.
4. All dimensions are in millimeters. Angles are in degrees.
5. Dimension b applies to the metallized terminal and is measured between 0.15mm and 0.30mm from the terminal tip.
6. The configuration of the pin #1 identifier is optional, but must be located within the zone indicated. The pin #1 identifier may be either a mold or mark feature.
7. Dimensions D2 and E2 are for the exposed pads which provide improved electrical and thermal performance.
8. Nominal dimensions are provided to assist with PCB Land Pattern Design efforts, see Intersil Technical Brief TB389.
9. Features and dimensions A2, A3, D1, E1, P & theta are present when Anvil singulation method is used and not present for saw singulation.
10. Compliant to JEDEC MO-220VHHC Issue I except for the "b" dimension.

Package Outline Drawing

M20.173

20 LEAD THIN SHRINK SMALL OUTLINE PACKAGE (TSSOP)

Rev 2, 5/10

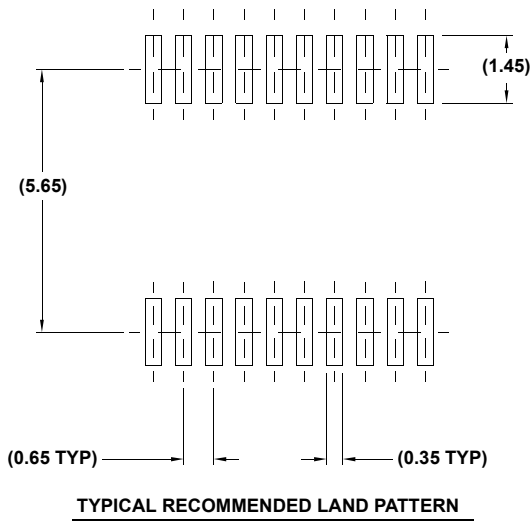
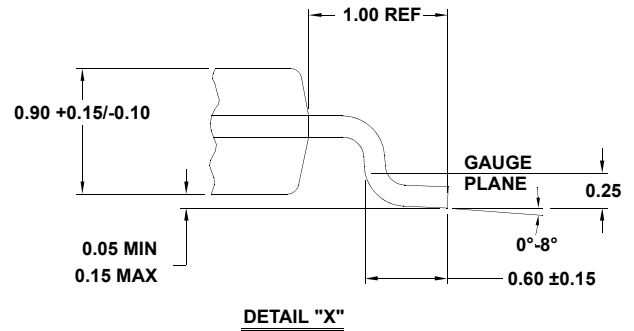
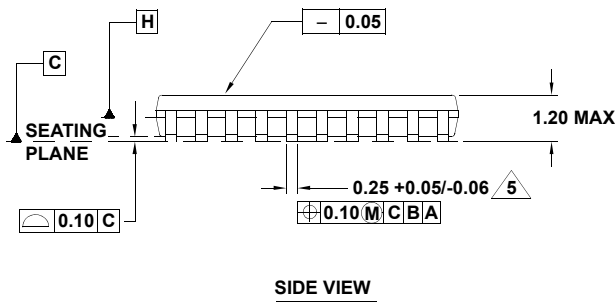
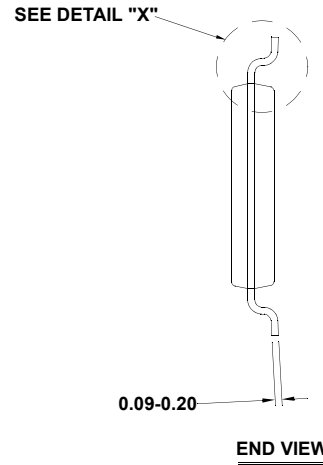
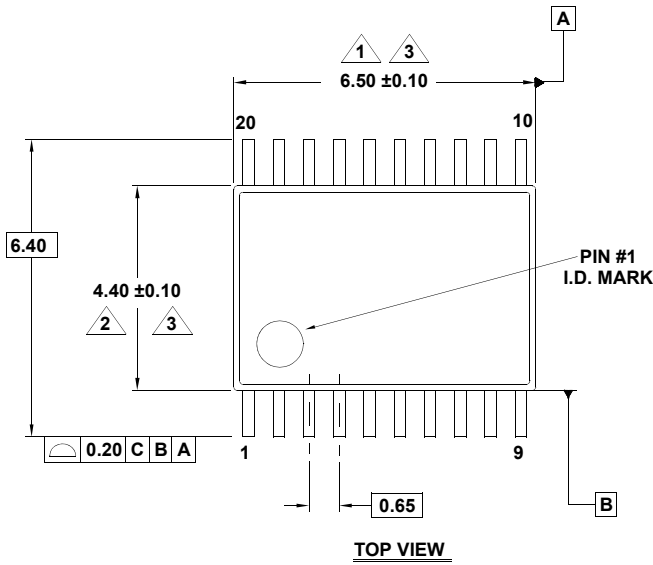

NOTES:

1. Dimension does not include mold flash, protrusions or gate burrs. Mold flash, protrusions or gate burrs shall not exceed 0.15 per side.
2. Dimension does not include interlead flash or protrusion. Interlead flash or protrusion shall not exceed 0.25 per side.
3. Dimensions are measured at datum plane H.
4. Dimensioning and tolerancing per ASME Y14.5M-1994.
5. Dimension does not include dambar protrusion. Allowable protrusion shall be 0.08mm total in excess of dimension at maximum material condition. Minimum space between protrusion and adjacent lead is 0.07mm.
6. Dimension in () are for reference only.
7. Conforms to JEDEC MO-153.

Looking for pricing, stock, or lifecycle information?

Click below to explore more details on WIN SOURCE:

- ⊖ [View ISL55143IRZ on WIN SOURCE](#)
- ⊖ [Renesas Electronics America](#) Information

Optimize Your Supply Chain with WIN SOURCE Solutions

- ✓ Global Sourcing Solution
- ✓ Obsolete Management
- ✓ Cost Control Management
- ✓ Shortage Management
- ✓ Alternative Solution
- ✓ Excess Inventory Management