



**THE DATASHEET OF
JAN2N3737**



NPN SILICON SWITCHING TRANSISTOR

Qualified per MIL-PRF-19500/395

DEVICES

2N3735 **2N3735L**
2N3737 **2N3737UB**

LEVELS
JAN
JANTX
JANTXV
JANS

ABSOLUTE MAXIMUM RATINGS ($T_C = +25^\circ\text{C}$ unless otherwise noted)

| Parameters / Test Conditions | Symbol | Min. | Unit |
|--|----------------|----------------------------|------------------|
| Collector-Emitter Voltage | V_{CEO} | 40 | Vdc |
| Collector-Base Voltage | V_{CBO} | 75 | Vdc |
| Emitter-Base Voltage | V_{EBO} | 5 | Vdc |
| Collector Current | I_C | 1.5 | Adc |
| Total Power Dissipation @ $T_A = +25^\circ\text{C}$ | P_T | 2N3735, 2N3735L 1.0 (1) | W |
| | | 2N3737 0.5 (3) | W |
| | | 2N3737UB 0.5 (5) | W |
| Total Power Dissipation @ $T_C = +25^\circ\text{C}$ | P_T | 2N3735, 2N3735L 2.9 (2) | W |
| | | 2N3737 1.9 (4) | W |
| | | 2N3737UB N/A | W |
| Operating & Storage Junction Temperature Range | T_J, T_{stg} | -65 to +200 | $^\circ\text{C}$ |

* Electrical characteristics for "L" suffix devices are identical to the "non L" corresponding devices.

- (1) Derate linearly at 5.71 mW/ $^\circ\text{C}$ above $T_A = +25^\circ\text{C}$
- (2) Derate linearly at 16.6 mW/ $^\circ\text{C}$ above $T_A = +25^\circ\text{C}$
- (3) Derate linearly at 2.86 mW/ $^\circ\text{C}$ above $T_A = +25^\circ\text{C}$
- (4) Derate linearly at 11.3 mW/ $^\circ\text{C}$ above $T_A = +25^\circ\text{C}$
- (5) Derate linearly at 3.07 mW/ $^\circ\text{C}$ above $T_A = +25^\circ\text{C}$
- (6) $T_A = +55^\circ\text{C}$ for UB on printed circuit board (PCB). PCB = FR4 .0625 inch (1.59MM) 1 - layer 1 oz Cu, horizontal, still air, pads (UB) = .034 inch (0.86 mm) x .048 inch (1.2 mm), $R_{\theta JA}$ with a defined thermal resistance condition included is measured at $P_T = 500\text{mW}$.

ELECTRICAL CHARACTERISTICS ($T_A = +25^\circ\text{C}$, unless otherwise noted)

| Parameters / Test Conditions | Symbol | Min. | Max. | Unit |
|--|---------------|------|-----------|-------------------------------------|
| OFF CHARACTERISTICS | | | | |
| Collector-Emitter Breakdown Voltage $I_C = 10\text{mAdc}$ | $V_{(BR)CEO}$ | 40 | | Vdc |
| Collector-Base Cutoff Current $V_{CB} = 75\text{Vdc}$ $V_{CB} = 30\text{Vd}$ | I_{CBO} | | 10 250 | μAdc ηAdc |

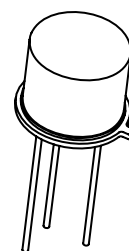

TO-5*
2N3735L

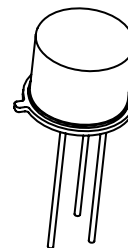

TO-39* (TO-205AD)
2N3735

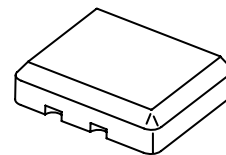

3 PIN
2N3737UB

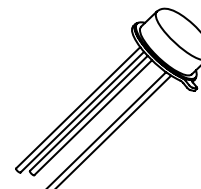

TO-46 (TO-206AB)
2N3737

ELECTRICAL CHARACTERISTICS ($T_A = +25^\circ\text{C}$, unless otherwise noted)

| Parameters / Test Conditions | Symbol | Min. | Max. | Unit |
|--|---------------|----------------------------|--------------------------|-------------------------|
| OFF CHARACTERISTICS | | | | |
| Collector- Emitter Cutoff Current $V_{CE} = 30\text{Vdc}$, $V_{EB} = 2.0\text{Vdc}$ $V_{CE} = 30\text{Vdc}$, $V_{EB} = 2.0\text{Vdc}$ $T_A = +150^\circ\text{C}$ | I_{CEX} | | 200 250 | nAdc μAdc |
| Emitter-Base Cutoff Current $V_{EB} = 5.0\text{Vdc}$ $V_{EB} = 4.0\text{Vdc}$ | I_{EBO} | | 10 100 | μAdc nAdc |
| ON CHARACTERISTICS ⁽¹⁾ | | | | |
| Forward-Current Transfer Ratio $I_C = 10\text{mAdc}$, $V_{CE} = 1.0\text{Vdc}$ $I_C = 150\text{mAdc}$, $V_{CE} = 1.0\text{Vdc}$ $I_C = 500\text{mAdc}$, $V_{CE} = 1.0\text{Vdc}$ $I_C = 1.0\text{Adc}$, $V_{CE} = 1.5\text{Vdc}$ $I_C = 1.5\text{Adc}$, $V_{CE} = 5.0\text{Vdc}$ | h_{FE} | 35 40 40 20 20 | 150 80 | |
| Collector-Emitter Saturation Voltage $I_C = 10\text{mAdc}$, $I_B = 1.0\text{mAdc}$ $I_C = 150\text{mAdc}$, $I_B = 15.0\text{mAdc}$ $I_C = 500\text{mAdc}$, $I_B = 50.0\text{mAdc}$ $I_C = 1.0\text{Adc}$, $I_B = 100\text{mAdc}$ | $V_{CE(sat)}$ | | 0.2 0.3 0.5 0.9 | Vdc |
| Base-Emitter Saturation Voltage $I_C = 10\text{mAdc}$, $I_B = 1.0\text{mAdc}$ $I_C = 150\text{mAdc}$, $I_B = 15.0\text{mAdc}$ $I_C = 500\text{mAdc}$, $I_B = 50.0\text{mAdc}$ $I_C = 1.0\text{Adc}$, $I_B = 100\text{mAdc}$ | $V_{BE(sat)}$ | | 0.8 1.0 1.2 1.4 | Vdc |

DYNAMIC CHARACTERISTICS

| | | | | |
|---|------------|-----|-----|----------------|
| Forward Current Transfer Ratio $I_C = 50\text{mAdc}$, $V_{CE} = 10\text{Vdc}$, $f = 100\text{MHz}$ | $ h_{fe} $ | 2.5 | 6.0 | |
| Delay Response $I_C = 1.0\text{Adc}$, $V_{BE} = 2\text{Vdc}$, $I_{B2} = 100\text{mA}$ $V_{CC} = 30\text{Vdc}$ | t_d | | 8 | ηs |
| Turn-Off Time $I_C = 1.0\text{Adc}$, $I_{B1} = I_{B2} = 100\text{mAdc}$, $V_{CC} = 30\text{Vdc}$ | t_{off} | | 60 | ηs |
| Rise Time $I_C = 1.0\text{Adc}$, $V_{BE} = 2\text{Vdc}$, $V_{CC} = 30\text{Vdc}$ | t_r | | 40 | ηs |
| Output Capacitance $V_{CB} = 10\text{Vdc}$, $I_E = 0$, $100\text{kHz} \leq f \leq 1.0\text{MHz}$ | C_{obo} | | 9 | pF |
| Input Capacitance $V_{EB} = 0.5\text{Vdc}$, $I_C = 0$, $100\text{kHz} \leq f \leq 1.0\text{MHz}$ | C_{ibo} | | 80 | pF |

(1) Pulse Test: Pulse Width = $300\mu\text{s}$, Duty Cycle $\leq 2.0\%$

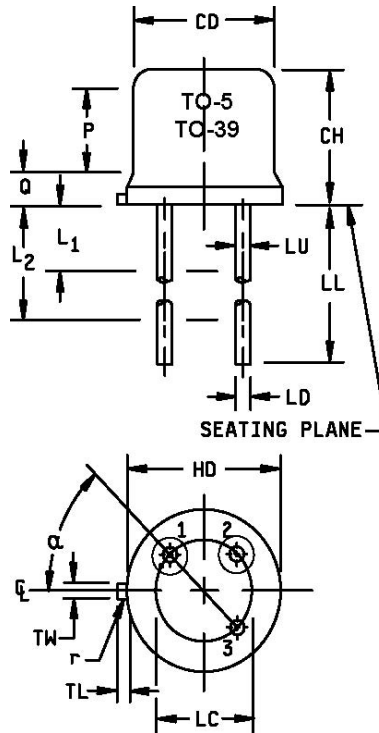
PACKAGE DIMENSIONS

2N3735 Dimensions TO-39
2N3735L Dimensions TO-5

| Ltr | Dimensions | | | | Notes |
|----------------|------------|------|-------------|-------|-------|
| | Inches | | Millimeters | | |
| | Min | Max | Min | Max | |
| CD | .305 | .355 | 7.75 | 9.02 | |
| CH | .240 | .260 | 6.10 | 6.60 | |
| HD | .355 | .370 | 9.02 | 9.40 | |
| LC | .200 TP | | 5.08 TP | | 6 |
| LD | .016 | .021 | 0.41 | 0.53 | 7 |
| LL | .500 | .750 | 12.70 | 19.05 | 7 |
| LU | .016 | .019 | 0.41 | 0.48 | 7 |
| L ₁ | | .050 | | 1.27 | 7 |
| L ₂ | .250 | | 6.35 | | 7 |
| P | .100 | | 2.54 | | |
| TL | .029 | .045 | 0.74 | 1.14 | 3 |
| TW | .028 | .034 | 0.71 | 0.86 | 9 |
| Q | | .040 | | 1.02 | 4 |
| r | | .010 | | 0.25 | 10 |
| α | 45° TP | | 45° TP | | 6 |

| Ltr | Dimensions | | | | Notes |
|----------------|------------|-------|-------------|-------|-------|
| | Inches | | Millimeters | | |
| | Min | Max | Min | Max | |
| CD | .305 | .355 | 7.75 | 9.02 | |
| CH | .240 | .260 | 6.10 | 6.60 | |
| HD | .355 | .370 | 9.02 | 9.40 | |
| LC | .200 TP | | 5.08 TP | | 6 |
| LD | .016 | .021 | 0.41 | 0.53 | 7 |
| LL | 1.500 | 1.750 | 38.10 | 44.45 | 7 |
| LU | .016 | .019 | 0.41 | 0.48 | 7 |
| L ₁ | | .050 | | 1.27 | 7 |
| L ₂ | .250 | | 6.35 | | 7 |
| P | .100 | | 2.54 | | |
| TL | .029 | .045 | 0.74 | 1.14 | 3 |
| TW | .028 | .034 | 0.71 | 0.86 | 9 |
| Q | | .040 | | 1.02 | 4 |
| R | | .010 | | 0.25 | 10 |
| α | 45° TP | | 45° TP | | 6 |

FIGURE 1: Physical dimensions – TO-39, TO-5

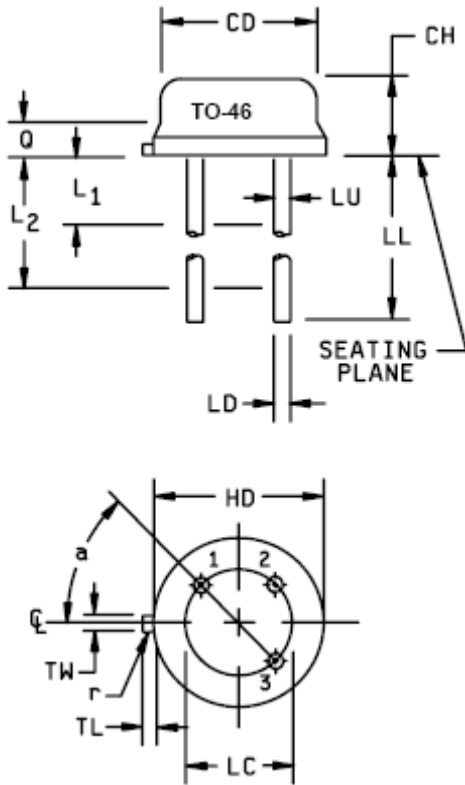
PACKAGE DIMENSIONS



| Ltr | Dimensions | | | | Notes |
|----------------|------------|-------|-------------|-------|-------|
| | Inches | | Millimeters | | |
| | Min | Max | Min | Max | |
| CD | .178 | .195 | 4.52 | 4.95 | |
| CH | .065 | .085 | 1.65 | 2.16 | |
| HD | .209 | .230 | 5.31 | 5.84 | |
| LC | .100 TP | | 2.54 TP | | 5 |
| LD | .016 | .021 | 0.41 | 0.53 | |
| LL | .500 | 1.750 | 12.70 | 44.45 | 6 |
| LU | .016 | .019 | 0.41 | 0.48 | 6 |
| L ₁ | | .050 | | 1.27 | 6 |
| L ₂ | .250 | | 6.35 | | 6 |
| Q | | .040 | | 1.02 | 3 |
| TL | .028 | .048 | 0.71 | 1.22 | 8 |
| TW | .036 | .046 | 0.91 | 1.17 | 4 |
| r | | .010 | | 0.25 | 9 |
| α | 45° TP | | 45° TP | | 5 |

NOTES:

- 1 Dimensions are in inches.
- 2 Millimeters are given for general information only.
- 3 Symbol TL is measured from HD maximum.
- 4 Details of outline in this zone are optional.
- 5 Leads at gauge plane .054 inch (1.37 mm) +.001 inch (0.03 mm) -.000 inch (0.00 mm) below seating plane shall be within .007 inch (0.18 mm) radius of TP relative to tab. Device may be measured by direct methods or by gauge.
- 6 Symbol LU applies between L1 and L2. Dimension LD applies between L2 and LL minimum.
- 7 Lead number three is electrically connected to case.
- 8 Beyond r maximum, TW shall be held for a minimum length of .011 inch (0.28 mm).
- 9 Symbol r applied to both inside corners of tab.
- 10 In accordance with ASME Y14.5M, diameters are equivalent to ϕx symbology.
- 11 Lead 1 is emitter, lead 2 is base, and lead 3 is collector.

FIGURE 2: Physical dimensions – TO-46 2N3737

PACKAGE DIMENSIONS

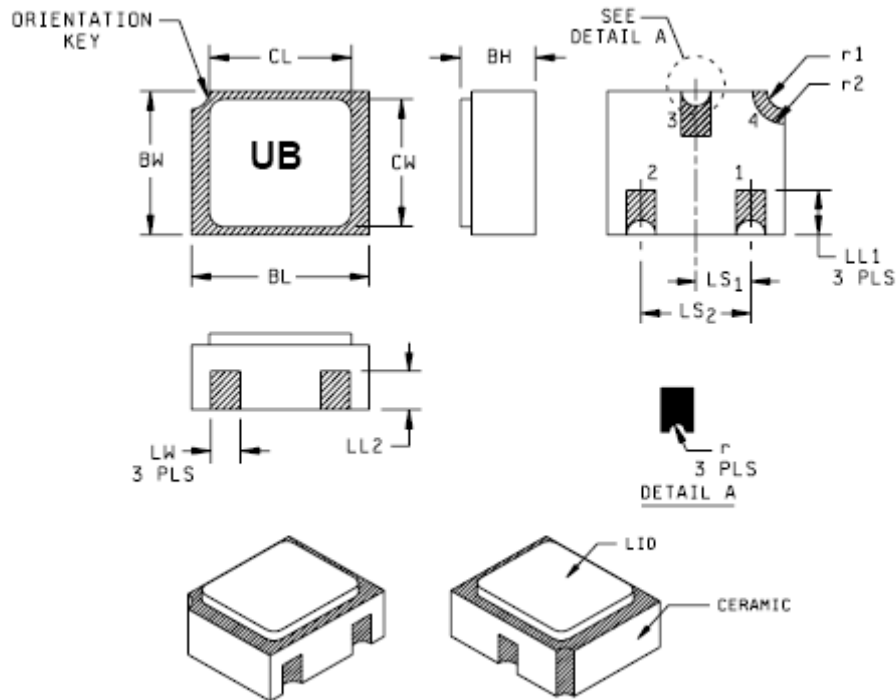

NOTES:

1. Dimensions are in inches.
2. Millimeters are given for general information only.
3. Hatched areas on package denote metalized areas.
4. Lid material: Kovar.
5. Pad 1 = Base, Pad 2 = Emitter, Pad 3 = Collector, Pad 4 = Shielding connected to the lid.
6. In accordance with ASME Y14.5m, diameters are Equivalent to ϕx symbology.

| Symbol | Dimensions | | | | Notes |
|--------|------------|------|-------------|------|-------|
| | Inches | | Millimeters | | |
| | Min | Max | Min | Max | |
| BH | .046 | .056 | 1.17 | 1.42 | |
| BL | .115 | .128 | 2.92 | 3.25 | |
| BW | .085 | .108 | 2.16 | 2.74 | |
| CL | | .128 | | 3.25 | |
| CW | | .108 | | 2.74 | |
| LL1 | .022 | .038 | 0.56 | 0.96 | |
| LL2 | .017 | .035 | 0.43 | 0.89 | |
| LS1 | .036 | .040 | 0.91 | 1.02 | |
| LS2 | .071 | .079 | 1.81 | 2.01 | |
| LW | .016 | .024 | 0.41 | 0.61 | |
| r | | .008 | | .203 | |
| R1 | | .012 | | .305 | |
| R2 | | .022 | | .559 | |

Looking for pricing, stock, or lifecycle information?

Click below to explore more details on WIN SOURCE:

- ⊖ [View JAN2N3737](#) on WIN SOURCE
- ⊖ [Microchip Technology](#) Information

Optimize Your Supply Chain with WIN SOURCE Solutions

- ✓ Global Sourcing Solution
- ✓ Obsolete Management
- ✓ Cost Control Management
- ✓ Shortage Management
- ✓ Alternative Solution
- ✓ Excess Inventory Management