



THE DATASHEET OF JANTX2N2605



PNP SILICON LOW POWER TRANSISTOR

Qualified per MIL-PRF-19500/354

DEVICES

2N2604 **2N2604UB**
2N2605 **2N2605UB**

LEVELS
JAN
JANTX
JANTXV

ABSOLUTE MAXIMUM RATINGS ($T_C = +25^\circ\text{C}$ unless otherwise noted)

Parameters / Test Conditions	Symbol	2N2604	2N2605	Unit
Collector-Base Voltage	V_{CBO}	80	70	Vdc
Collector-Emitter Voltage	V_{CEO}	60		Vdc
Emitter-Base Voltage	V_{EBO}	6.0		Vdc
Collector Current	I_C	30		mAdc
Total Power Dissipation @ $T_A = +25^\circ\text{C}^{(1)}$	P_T	400		mW/ $^\circ\text{C}$
Operating & Storage Junction Temperature Range	T_J, T_{stg}	-65 to +200		$^\circ\text{C}$

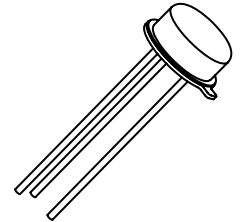

TO-46 (TO-206AB)

THERMAL CHARACTERISTICS

Parameters / Test Conditions	Symbol	Max.	Unit
Thermal Resistance, Junction-to-Ambient	$R_{\theta JA}$	437	$^\circ\text{C}/\text{mW}$
UB		275	

Note:

1/ Consult 19500/354 for thermal curves

ELECTRICAL CHARACTERISTICS ($T_A = +25^\circ\text{C}$, unless otherwise noted)

Parameters / Test Conditions	Symbol	Min.	Max.	Unit	
OFF CHARACTERISTICS					
Collector-Base Cutoff Current	I_{CBO}			uAdc	
$V_{CB} = 80\text{V dc}$ 2N2604, UB					10.0
$V_{CB} = 70\text{V dc}$ 2N2605, UB					10.0
$V_{CB} = 50\text{V dc}$ 2N2604, 2N2605, UB					10.0
$V_{CB} = 50\text{V dc}, T_A = +150^\circ\text{C}$ 2N2604, 2N2605, UB		5.0		uAdc	
Collector-Emitter Breakdown Current $I_C = 10\text{mAdc}$	$V_{(BR)CEO}$	60		Vdc	
Emitter-Base Cutoff Current	I_{EBO}			uAdc	
$V_{EB} = 6.0\text{Vdc}$					2.0
$V_{EB} = 5.0\text{Vdc}$				ηAdc	
Collector-Emitter Cutoff Current $V_{CE} = 50\text{Vdc}$	I_{CES}		10	ηAdc	

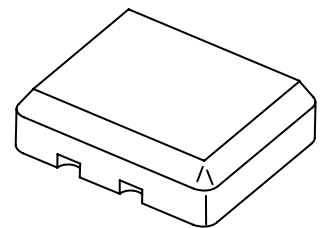

UB Package

ELECTRICAL CHARACTERISTICS ($T_A = +25^\circ\text{C}$, unless otherwise noted) (CONT.)

Parameters / Test Conditions	Symbol	Min.	Max.	Unit
ON CHARACTERISTICS ⁽²⁾				
Forward-Current Transfer Ratio $I_C = 10\mu\text{A}$, $V_{CE} = 5.0\text{Vdc}$	h_{FE}	2N2604, UB 2N2605, UB	40 100	120 300
$I_C = 500\mu\text{A}$, $V_{CE} = 5.0\text{Vdc}$		2N2604, UB 2N2605, UB	60 150	180 450
$I_C = 10\text{mA}$, $V_{CE} = 5.0\text{Vdc}$		2N2604, UB 2N2605, UB	40 100	160 400
$I_C = 10\text{mA}$, $V_{CE} = 5.0\text{Vdc}$, $T_A = -55^\circ\text{C}$		2N2604, UB 2N2605, UB	15 30	
Collector-Emitter Saturation Voltage $I_C = 10\text{mA}$, $I_B = 500\mu\text{A}$		$V_{CE(sat)}$		0.3
Base-Emitter Saturation Voltage $I_C = 10\text{mA}$, $I_B = 500\mu\text{A}$	$V_{BE(sat)}$	0.7	0.9	Vdc

DYNAMIC CHARACTERISTICS

Parameters / Test Conditions	Symbol	Min.	Max.	Unit
Small-Signal Short-Circuit Input Impedance $I_C = 1.0\text{mA}$, $V_{CB} = 5.0\text{Vdc}$, $f = 1.0\text{kHz}$	h_{ie}	2N2604, UB 2N2605, UB	1.0 2.0	10 20
Small-Signal Open-Circuit Forward Current Output Admittance $I_C = 1.0\text{mA}$, $V_{CE} = 5.0\text{Vdc}$, $f = 1.0\text{kHz}$	h_{oe}	2N2604, UB 2N2605, UB		40 60
Small-Signal Short-Circuit Forward Current Transfer Ratio $I_C = 1.0\text{mA}$, $V_{CE} = 5.0\text{Vdc}$, $f = 1.0\text{kHz}$	h_{fe}	2N2604, UB 2N2605, UB	60 150	180 450
Magnitude of Small-Signal Forward Current Transfer Ratio $I_C = 0.5\text{mA}$, $V_{CE} = 5.0\text{Vdc}$, $f = 30\text{MHz}$	$ h_{fe} $		1.0	8.0
Output Capacitance $V_{CB} = 5.0\text{Vdc}$, $I_E = 0$, $100\text{kHz} \leq f \leq 1.0\text{MHz}$	C_{obo}			6.0
Noise Figure $V_{CE} = 5.0\text{Vdc}$, $I_C = 10\mu\text{A}$, $R_g = 10\text{k}\Omega$, $f = 100\text{Hz}$ $V_{CE} = 5.0\text{Vdc}$, $I_C = 10\mu\text{A}$, $R_g = 10\text{k}\Omega$, $f = 1.0\text{kHz}$ $V_{CE} = 5.0\text{Vdc}$, $I_C = 10\mu\text{A}$, $R_g = 10\text{k}\Omega$, $f = 10\text{kHz}$	F_1 F_2 F_3			5.0 3.0 3.0

(2) Pulse Test: Pulse Width = 300 μs , Duty Cycle $\leq 2.0\%$

PACKAGE DIMENSIONS

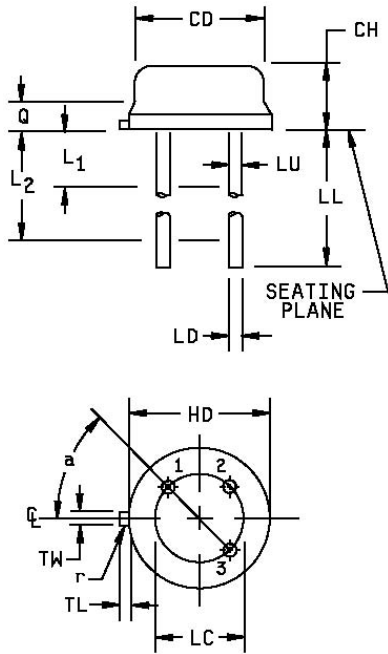

Symbol	Dimensions				Note
	Inches		Millimeters		
	Min	Max	Min	Max	
CD	.178	.195	4.52	4.95	
CH	.065	.085	1.65	2.16	
HD	.209	.230	5.31	5.84	
LC	.100 TP		2.54 TP		5
LD	.016	.021	0.41	0.53	6
LL	.500	1.750	12.70	44.45	6
LU	.016	.019	0.41	0.48	6
L ₁		.050		1.27	6
L ₂	.250		6.35		6
Q		.040		1.02	4
TL	.028	.048	0.71	1.22	3, 8
TW	.036	.046	0.91	1.17	3, 8
r		.010		0.25	9
α	45° TP		45° TP		5

NOTES:

- Dimensions are in inches. Lead 1 is emitter, lead 2 is base, and lead 3 is collector.
- Millimeters are given for general information only.
- Symbol TL is measured from HD maximum.
- Details of outline in this zone are optional.
- Leads at gauge plane .054 +.001 -.000 inch (1.37 +0.03 -0.00 mm) below seating plane shall be within .007 inch (0.18 mm) radius of true position (TP) at maximum material condition (MMC) relative to tab at MMC. The device may be measured by direct methods or by the gauge and gauging procedure.
- Symbol LU applies between L₁ and L₂. Dimension LD applies between L₂ and LL minimum.
- Lead number three is electrically connected to case.
- Beyond r maximum, TW shall be held for a minimum length of .011 inch (0.28 mm).
- Symbol r applied to both inside corners of tab.
- In accordance with ASME Y14.5M, diameters are equivalent to φx symbology.

FIGURE 1. Physical dimensions - (TO-46).

PACKAGE DIMENSIONS

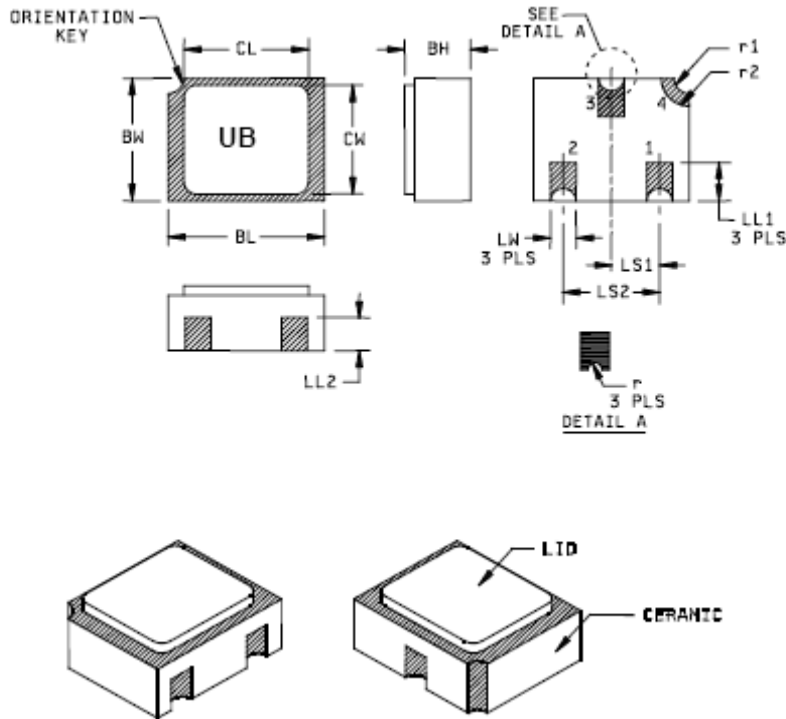

Symbol	Dimensions				Notes
	Inches		Millimeters		
	Min	Max	Min	Max	
BH	.046	.056	1.17	1.42	
BL	.115	.128	2.92	3.25	
BW	.085	.108	2.16	2.74	
CL		.128		3.25	
CW		.108		2.74	
LL ₁	.022	.038	0.56	0.97	
LL ₂	.017	.035	0.43	0.89	

Symbol	Dimensions				Notes
	Inches		Millimeters		
	Min	Max	Min	Max	
LS ₁	.035	.039	0.89	0.99	
LS ₂	.071	.079	1.80	2.01	
LW	.016	.024	0.41	0.61	
r		.008		0.20	
r ₁		.012		0.31	
r ₂		.022		0.56	

NOTES:

1. Dimensions are in inches.
2. Millimeters are given for general information only.
3. Hatched areas on package denote metallized areas
4. Pad 1 = Base, Pad 2 = Emitter, Pad 3 = Collector, Pad 4 = Shielding connected to the lid.
5. In accordance with ASME Y14.5M, diameters are equivalent to $\phi \times$ symbology.

FIGURE 2. Physical dimensions, surface mount (UB version).

Looking for pricing, stock, or lifecycle information?

Click below to explore more details on WIN SOURCE:

- ⊖ [View JANTX2N2605 on WIN SOURCE](#)
- ⊖ [Microchip Technology](#) Information

Optimize Your Supply Chain with WIN SOURCE Solutions

- ✓ Global Sourcing Solution
- ✓ Obsolete Management
- ✓ Cost Control Management
- ✓ Shortage Management
- ✓ Alternative Solution
- ✓ Excess Inventory Management