

System Motor Driver ICs for CD / DVD / Blu-ray Drive and Recorder

# System Motor Driver IC for Half Height Drive (Sensor less)



BD7755RFV

No.10012EAT01

## ●Description

BD7755RFV are ICs, developed for the spindle motor, actuator coil, tilt coil, stepping motor, SA stepping motor and the loading motor drive of the desktop Blu-ray drive and Blu-ray recorder. Spindle driver adopted sensorless drive system, and the hall sensor (3 pieces) of the motor position detection is not needed, it is suitable for making of flexible cable conserve wiring and the reductions of external parts. The low rotation mode is built in, and stability and low-speed a rotation is achieved. The spindle, stepping and SA stepping use power MOSFET to reduce power consumption and the actuator, tilt, and loading driver use a linear BTL drive system to reduce noise.

## ●Features

- 1) The low-speed stability rotation is achieved with built-in the low rotation mode.
- 2) The hall sensor is unnecessary according to 3 aspect sensorless drive system.
- 3) The spindle motor driver achieves stability high speed start by ROHM's own energizing method.
- 4) Highly effective spindle, stepping and SA stepping is achieved by PWM control driver. And the output current detection resistance of stepping and SA stepping is unnecessary by built-in internal detection circuit.
- 5) The actuator, tilt and loading driver achieve low noise by using linear BTL drive system.
- 6) ON/OFF of loading and other channels, brake mode of spindle driver and standby mode are selectable by the two control terminals.
- 7) Built-in thermal-shut down circuit.
- 8) Improved heat radiation efficiency utilizing HTSSOP package.

## ●Applications

For desktop Blu-ray drive

## ●Absolute maximum ratings

Parameter	Symbol	Ratings	Unit
POWER MOS power supply voltage 1	SPVM, SLVM	15 #1	V
POWER MOS power supply voltage 2	SAVM	7 #2	V
Preblock/BTL power block power supply voltage	Vcc, AVM, LDVM	15	V
PWM control block power supply voltage	DVcc	7	V
Power dissipation	Pd	1.5 #3	W
Operating temperature range	Topr	-20 ~ 70	°C
Storage temperature	Tstg	-55 ~ 150	°C
Junction temperature	Tjmax	150	°C

#1 POWER MOS output terminals (40~43pin, 46~48pin) are contained.

#2 POWER MOS output terminals (35~38pin) are contained.

#3 PCB mounting (70mmX70mmX1.6mm, occupied copper foil is less than 3%, glass epoxy standard board).  
Reduce by 12mW/°C over 25°C

●Recommended operating conditions

(Set the power supply voltage with consideration to power dissipation)

Parameter	Symbol	Ratings			Unit
		Min.	Typ.	Max.	
Spindle / Sled motor driver power block power supply voltage	SPVM,SLVM	—	Vcc #4	—	V
Pre block power supply voltage	Vcc	10.8	12	13.2	V
Loading driver power block supply voltage	LDVM	4.3	5.0	Vcc	V
SA, Actuator driver power block power supply voltage	SAVM,AVM	4.3	5.0	5.5	V
PWM control block power supply voltage	DVcc	4.3	5.0	5.5	V
Spindle driver output current	Iosp	—	1.0	2.5 #5	A
Actuator, SA, sled, loading motor driver output current	Ioo	—	0.5	0.8	A

#4 Set the same supply voltage to SPVM, SLVM and Vcc.

#5 The current is guaranteed 3.5A in case of the Short-circuit braking mode and the current which is turned on/off in a duty-ratio of less than 1/10 with a maximum on-time of 5msec

### ●Electrical characteristics

(Unless otherwise noted, Ta=25°C, Vcc=SPVM=SLVM=12V, DVcc=AVM=SAVM= LDVM=5V, Vc=1.65V, RL=8Ω, RLSP=2Ω)

Parameter	Symbol	Limits			Unit	Conditions
		MIN.	TYP.	MAX.		
<b>Circuit current</b>						
Quiescent current 1	IQ1	—	14	30	mA	Vcc>Loading OFF)
Quiescent current 2	IQ2	—	7.5	16	mA	Vcc>Loading ON)
Quiescent current 3	IQ3	—	7	14	mA	DVcc
Standby-on current 1	IST1	—	1.1	2.4	mA	Vcc
Standby-on current 2	IST2	—	0.16	0.4	mA	DVcc
<b>Sled driver block</b>						
Input dead zone (one side)	VDZSL	0	30	80	mV	
Input output gain	gmSL	0.75	1.0	1.25	A/V	
Output On resistor (top and bottom)	RONSL	—	2.2	3.8	Ω	IL=500mA
Output limit current	ILIMSL	0.8	1.1	1.4	A	
PWM frequency	fosc	—	100	—	kHz	
<b>Spindle driver block&lt;Torque instruction input / output&gt;</b>						
Input dead zone (one side)1	VDZSP1	20	55	90	mV	VLRPM=L
Input dead zone (one side)2	VDZSP2	20	240	450	mV	VLRPM=H
Input output gain 'H'	gmSPH	2.68	3.5	4.32	A/V	VLRPM=L
Input output gain 'L'	gmSPL	0.53	0.7	0.87	A/V	VLRPM=H
Output On resistor (top and bottom)	RONSP	—	1.0	1.7	Ω	IL=500mA
Output limit current	ILIMSP	1.35	1.6	1.85	A	RSPLIM=1.5kΩ
PWM frequency	fosc	—	167	—	kHz	
<b>FG output, PRTFLG output</b>						
High voltage	VOH	—	4.9	—	V	100kΩ pull up to DVcc
Low voltage	VOL	—	0.1	—	V	
<b>Focus / Tracking / Tilt driver block</b>						
Output offset voltage	VOFA	-50	0	50	mV	
Output saturation voltage (top and bottom)	VOHA	—	0.9	1.8	V	IL=500mA
Voltage gain H	GVAH	19.6	21.6	23.6	dB	VLRPM=L
Voltage gain L	GVAL	13.6	15.6	17.6	dB	VLRPM=H
<b>SA stepping driver block</b>						
Input dead zone (one side)	VDZSA	40	80	160	mV	
Input output gain	gmSA	0.15	0.2	0.25	A/V	
Output On resistor (top and bottom)	RONSA	—	1.3	2.5	Ω	IL=200mA
Output limit current	ILIMSA	0.28	0.4	0.52	A	
PWM frequency	fosc	—	100	—	kHz	
<b>Loading driver block</b>						
Output offset voltage	VOFLD	-50	0	50	mV	
Output saturation voltage (top and bottom) 1	VOLD1	—	0.7	1.6	V	IL=500mA LDVM=5V
Output saturation voltage (top and bottom) 2	VOLD2	—	2.1	3.6	V	IL=500mA LDVM=12V
Voltage gain	GVLD	15.5	17.5	19.5	dB	
<b>CTL1,CTL2, LRPM</b>						
Input high voltage	VIH	2.5	—	3.7	V	
Input low voltage	VIL	GND	—	0.5	V	
<b>Others</b>						
VC drop-muting	VMVC	0.4	0.7	1.0	V	
Vcc drop-muting	VMVcc	3.45	3.85	4.25	V	

\*This product is not designed to be radiation-resistant.

●Block diagram

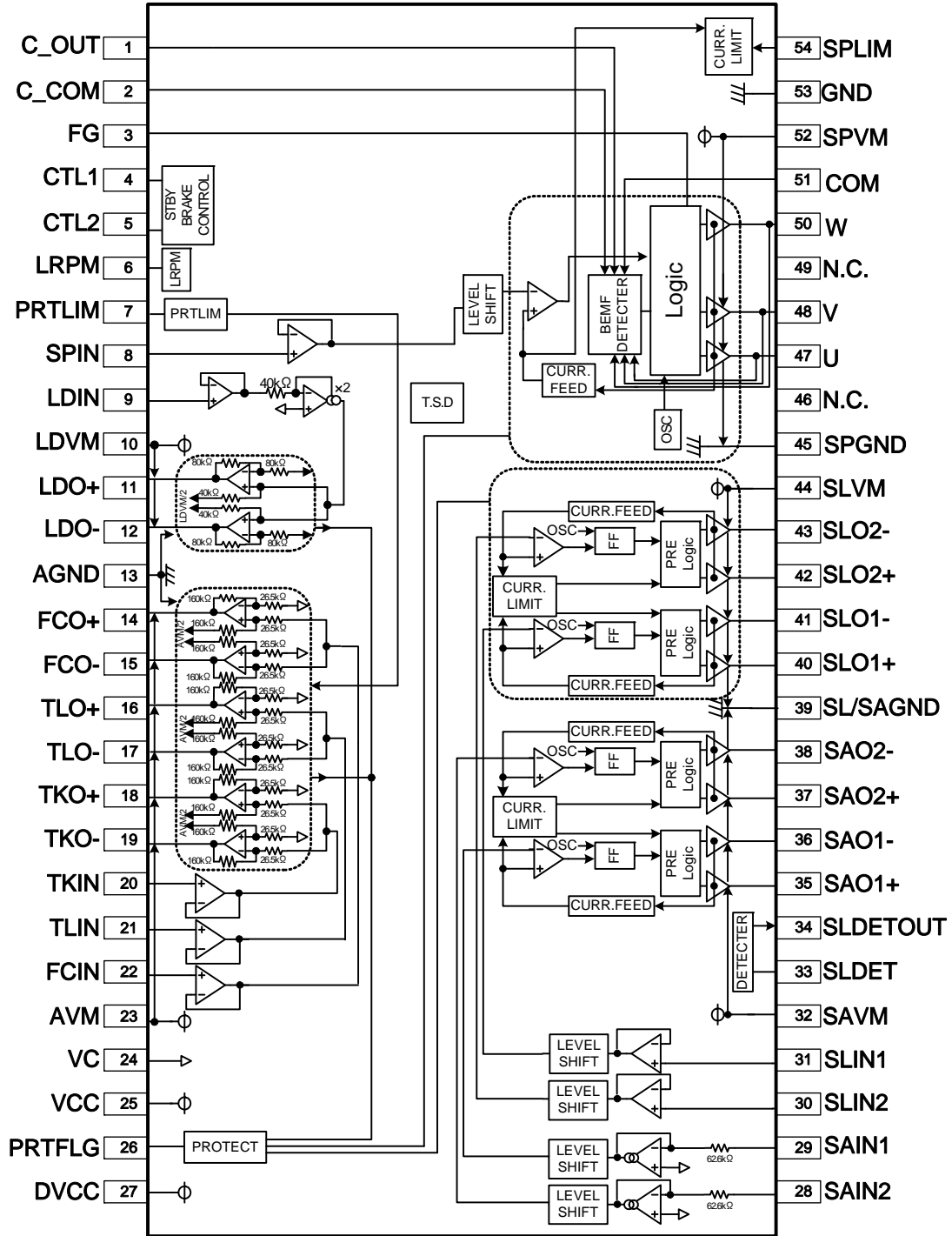

## ●Pin description

No.	Symbol	Description	No.	Symbol	Description
1	C_OUT	Smooth capacitor connection terminal (output side)	28	SAIN2	SA driver 2 input
2	C_COM	Smooth capacitor connection terminal (com side)	29	SAIN1	SA driver 1 input
3	FG	Frequency generator output	30	SLIN2	Sled driver 2 input
4	CTL1	Driver logic control 1 input	31	SLIN1	Sled driver 1 input
5	CTL2	Driver logic control 2 input	32	SAVM	SA driver power block power supply
6	LRPM	Low rotation mode change terminal	33	SLDET	Sled motor detection signal control input
7	PRTLIM	Adjustable resistor connection for actuator protection	34	SLDETOUT	Sled motor detection signal output
8	SPIN	Spindle driver input	35	SAO1+	SA driver 1 positive output
9	LDIN	Loading driver input	36	SAO1-	SA driver 1 negative output
10	LDVM	Loading driver block power supply	37	SAO2+	SA driver 2 positive output
11	LDO+	Loading driver positive output	38	SAO2-	SA driver 2 negative output
12	LDO-	Loading driver negative output	39	SL/SAGND	Sled/SA driver block pre and power ground
13	AGND	BTL driver block GND	40	SLO1+	Sled driver 1 positive output
14	FCO+	Focus driver positive output	41	SLO1-	Sled driver 1 negative output
15	FCO-	Focus driver negative output	42	SLO2+	Sled driver 2 positive output
16	TLO+	Tilt driver positive output	43	SLO2-	Sled driver 2 negative output
17	TLO-	Tilt driver negative output	44	SLVM	Sled motor driver power supply
18	TKO+	Tracking driver positive output	45	SPGND	Spindle driver power ground
19	TKO-	Tracking driver negative output	46	N.C.	N.C.
20	TKIN	Tracking driver input	47	U	Spindle driver output U
21	TLIN	Tilt driver input	48	V	Spindle driver output V
22	FCIN	Focus driver input	49	N.C.	N.C.
23	AVM	Actuator driver block power supply	50	W	Spindle driver output W
24	VC	Reference voltage input	51	COM	Motor coil center point input
25	Vcc	Pre block power supply	52	SPVM	Spindle driver power supply
26	PRTFLG	Protection flag output	53	GND	Pre block GND
27	DVcc	PWM block control power supply	54	SPLIM	Adjustable resistor connection for spindle driver current limit

\*Positive/negative of the output terminals is determined in reference to those of the input terminals.

●Equivalent-circuit diagram of the terminals

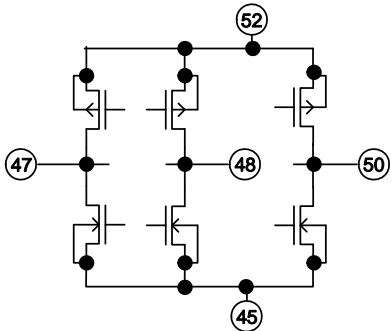
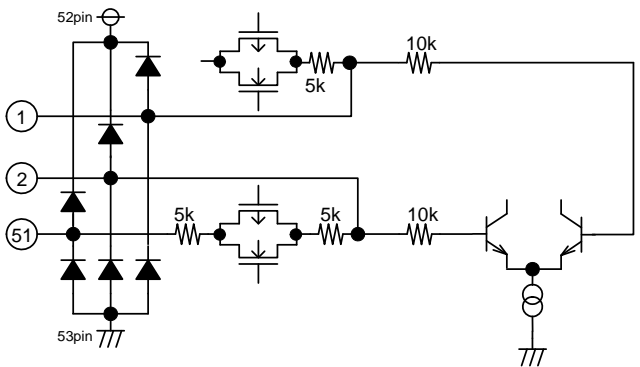
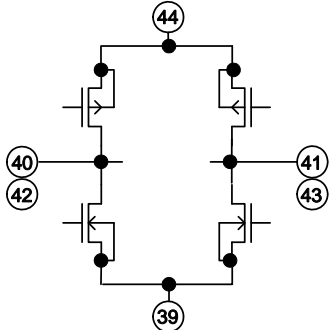
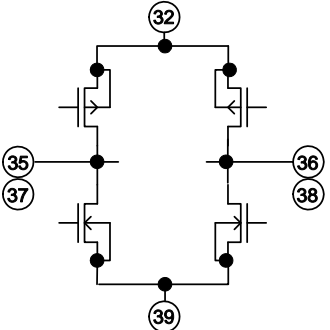
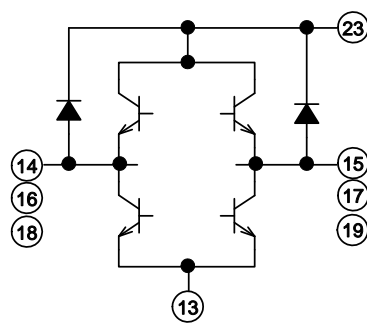
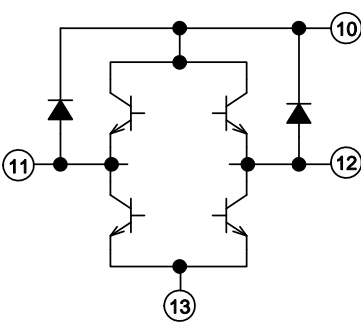
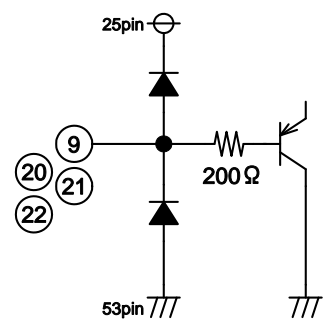
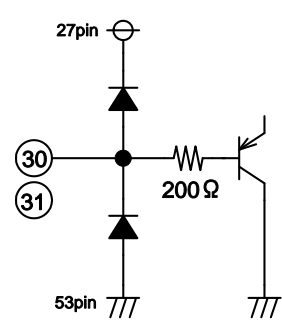
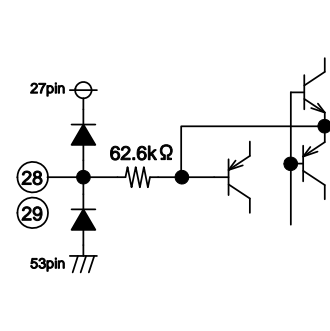
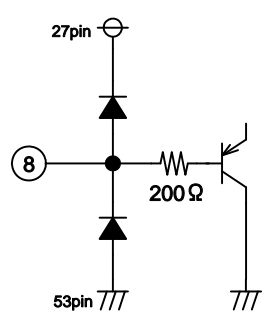
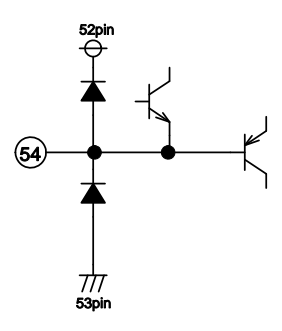
<p>Three-phase motor driver output</p>	<p>BEMF voltage detection input</p>	
		
<p>PWM driver output SLED1,2</p>	<p>PWM driver output SA1,2</p>	<p>BTL driver output FC,TK,TL</p>
		
<p>BTL driver output LD</p>	<p>BTL driver input FC,TK,TL,LD</p>	<p>PWM driver input SLED1,2</p>
		
<p>PWM driver input SA1,2</p>	<p>PWM driver input Spindle</p>	<p>Spindle current limit input</p>
		

●Equivalent-circuit diagram of the terminals

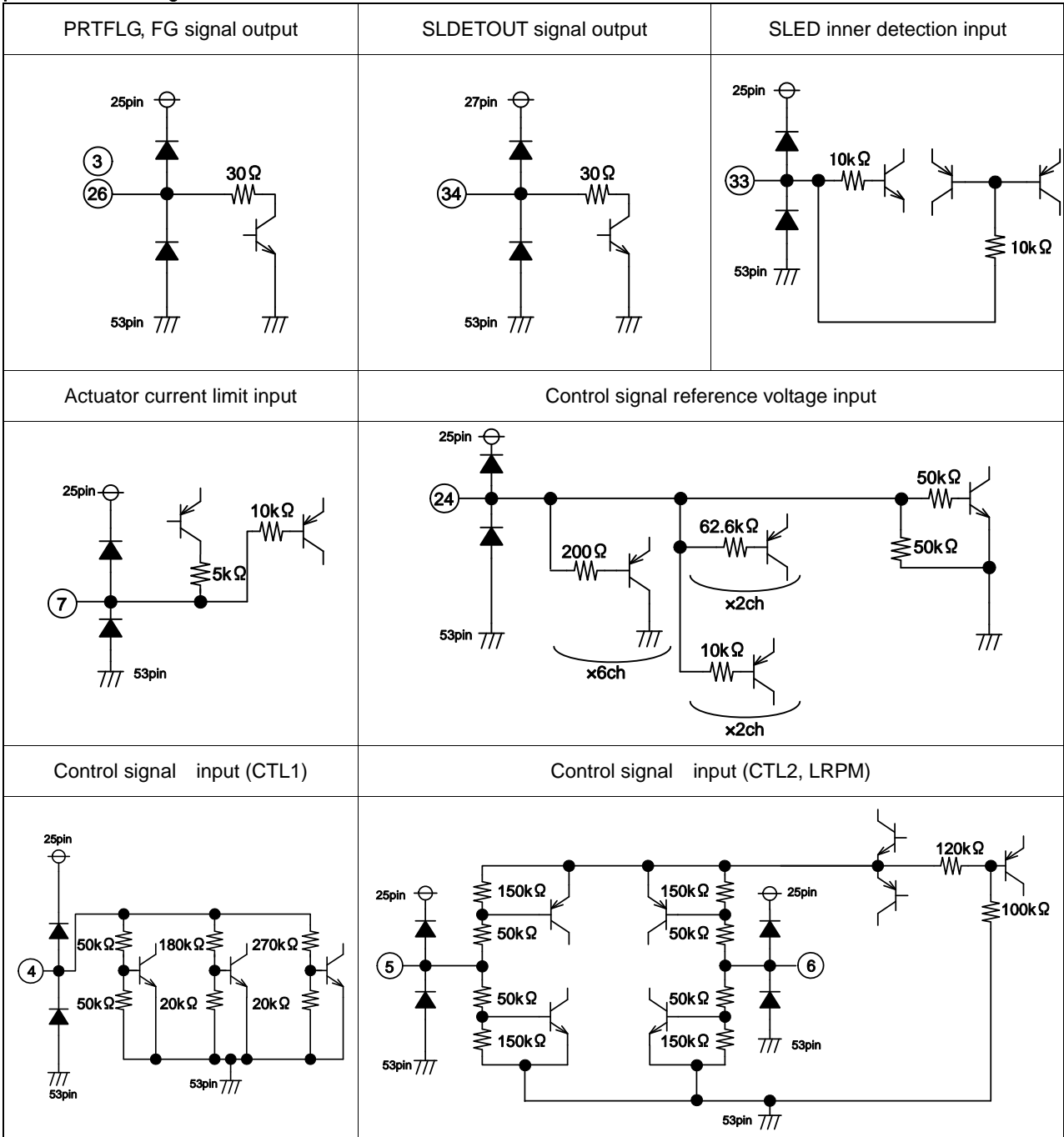

● Test circuit

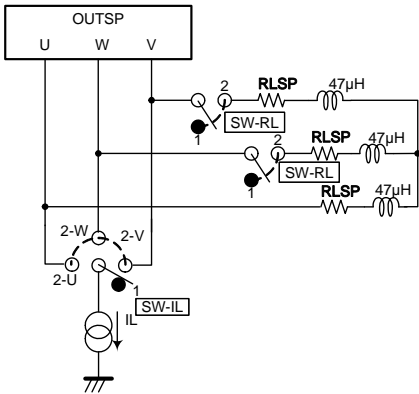
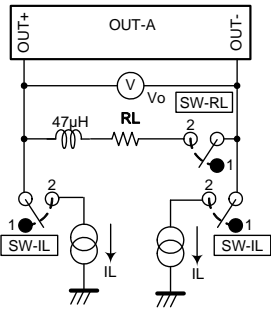
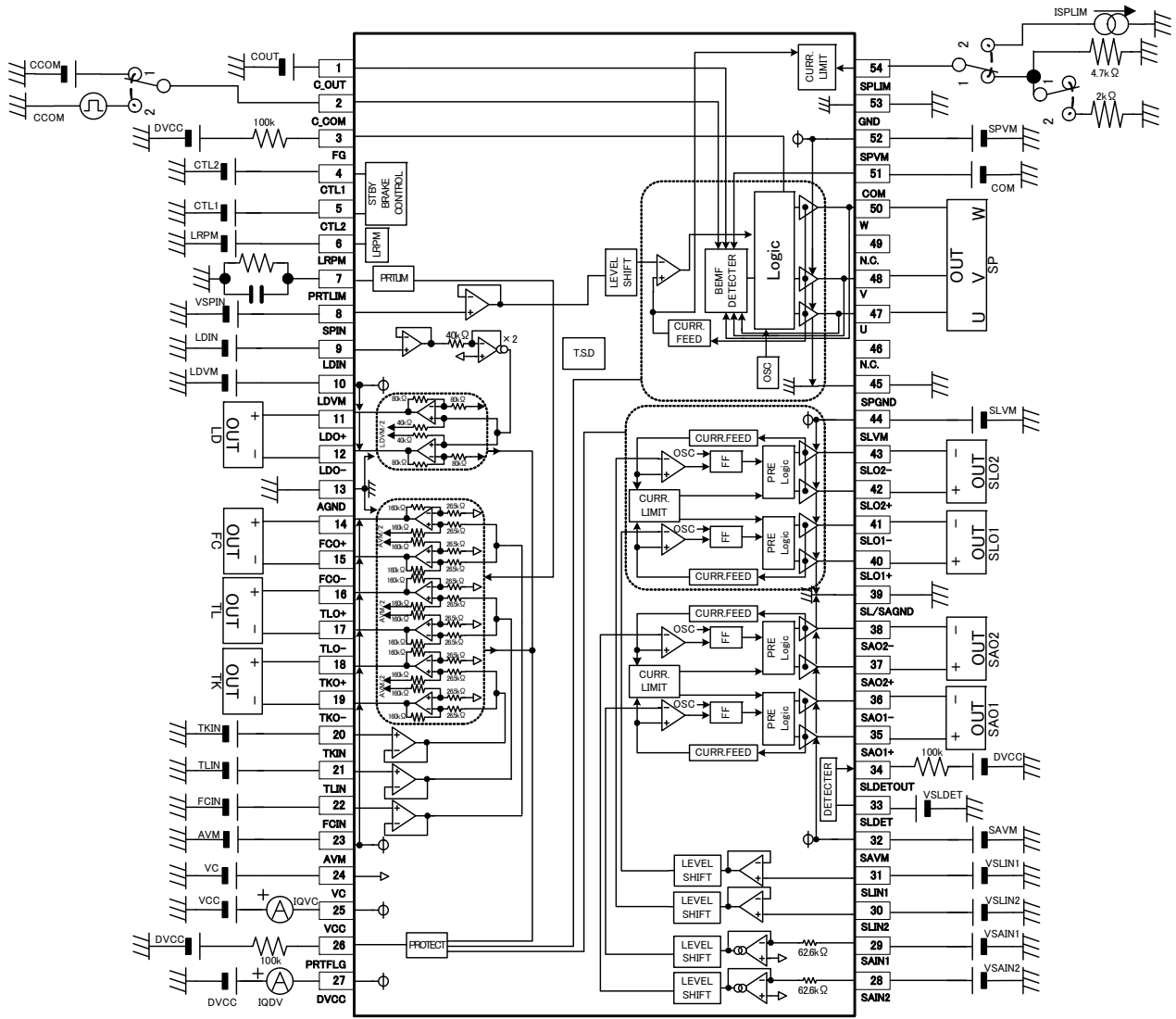

## ●Functional description

### 1-1. Driver logic control terminal 1 and 2 (CTL1,2)

All drivers and spindle-drive braking modes can be switched on/off by inputting combinations of H-level signal (higher than 2.5V and lower than 3.7V), L-level signal (lower than 0.5V) and HiZ signal (open) to these terminals.

#### • Driver ON/OFF logic table

mode	CTL1	CTL2	SP	SL(2ch)	ACT(3ch)	SA(2ch)	LOADING	
①	L, HiZ	L, HiZ	×	×	×	×	×	
②	H	L	×	○	×	×	○	
③	H	HiZ	○	○	○	×	×	
④	L, HiZ	H	○	○	○	○	×	○:ON
⑤	H	H	○	○	○	○	×	×:OFF

- ① Stand-by mode  
The IC is brought into stand-by mode, and its power dissipation can be limited.
- ② Drivers muting  
All output channels, except the loading and sled motor are muted and their outputs are turned off.
- ③ SA mute mode  
The loading and SA driver are muted.
- ④⑤ Loading OFF mode  
Only the loading driver is muted.

#### • Spindle braking mode table

mode	CTL1	CTL2	SPIN > VC	SPIN < VC
③	H	HiZ	Forward-rotation mode	Reverse-rotation braking mode (LRPM=L)
④	L, HiZ	H		Short-circuit braking mode
⑤	H	H		Reverse-rotation braking mode (LRPM=L)

- ③⑤ Reverse-rotation braking mode (spindle)  
When SPIN < VC, all output are shorted to SPVM in 4500rpm (Typ.) or more, in less than 4500rpm (Typ.) the output become reverse-rotation braking mode.  
Rotation speed is less than 140rpm when SPIN < VC, all the output are shorted to SPVM.  
(However, the above-mentioned rotational speed is expressed in the case of 12pole motor.)
- ④ Short-circuit braking mode (spindle)  
All the spindle driver outputs are shorted to SPVM when SPIN < VC.

### 1-2. Spindle output mode

The spindle output changes as follows by the setting of LRPM and SPIN. (CTL1=H,CTL2=H or HiZ)

Rotation speed	0rpm	400rpm	4500rpm
Normal mode	SPIN>VC	120° energizing	150° energizing
	SPIN<VC	120° energizing	150° energizing      Short brake
⑥ LRPM mode	SPIN>VC	120° energizing	
	SPIN<VC	(H,Hi-Z,Hi-Z)	

\* PWM frequency becomes 30kHz (Typ.) in LRPM mode.  
The torque at SPIN<VC becomes a counter torque

- ⑥ Low rotation mode  
Please make to low rotation mode (LRPM=HI) after it starts in normal mode (LRPM=L).

### 1-3. Gain switching mode

Spindle driver and actuator driver can be switched on/off by inputting combinations of H-level signal (higher than 2.5V and lower than 3.7V), L-level signal (lower than 0.5V) and HiZ signal (open) to LRPM terminal.

LRPM	SP Gain	ACT Gain (3ch)
L	H gain (3.5A/V ± 0.82A/V)	H gain (21.6dB ± 2dB)
HiZ	L gain (0.7A/V ± 0.17A/V)	H gain (21.6dB ± 2dB)
H	L gain (0.7A/V ± 0.17A/V)	L gain (15.6dB ± 2dB)

2. Output limit for spindle (SPLIM)

$$ILIMSP = \frac{A}{RSPLIM(\Omega)} (A) \quad A = 2420$$

3. Torque command (SPIN) (SLIN1,2) (SAIN1,2)

The relation between (the torque command inputs) and (Iosp or Ioo) is expressed in the figure below: The gain is defined by the inclination between two points. (Please exclude the dead zone from the input voltage when calculating Iop. )

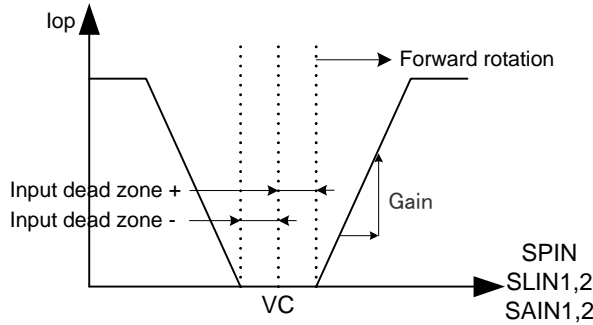

4. FG output (FG)

3FG output begins after 90° degrees in electric angle, after the start mode ends and the BEMF detection starts. When the rotational speed becomes 24rpm (Max.) or less in case of brake, the FG output is fixed to high. The above-mentioned rotation speed applies to the 12 pole motor.

5. Input/Output timing chart

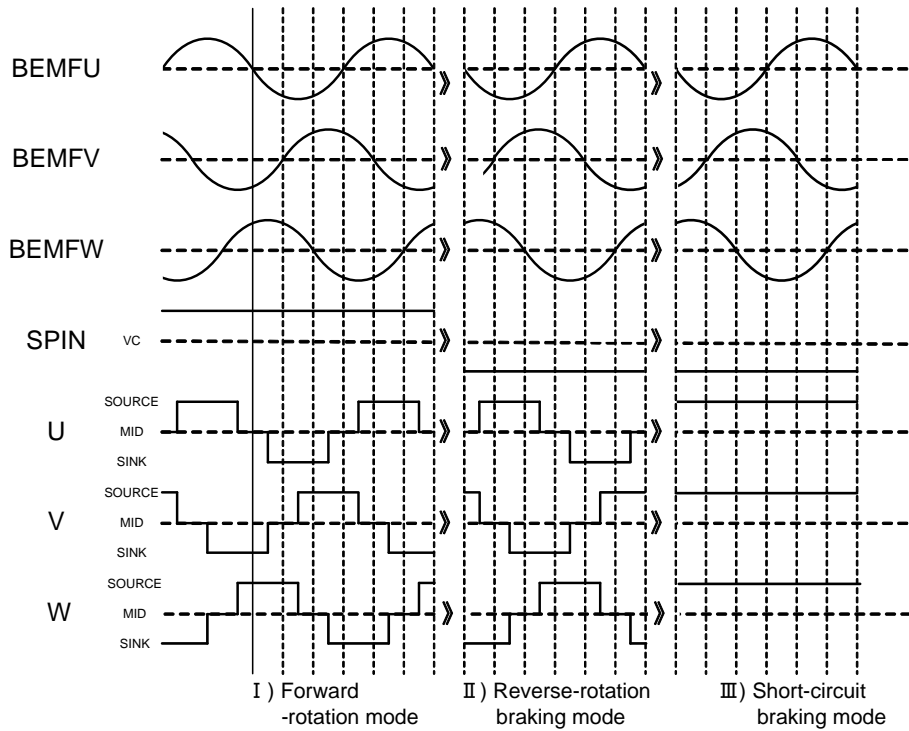

6. Protect system 1

It is a function to mute the actuator outputs when the IC outputs the current more than the setting threshold value IPRTLIM for 1.2sec because of the protection for the focus, the tracking, and the tilt coil. Outputs are muted similarly when the output current of two or three CHs continuously exceed the threshold for 1.2sec. It returns to normal operation by setting CTL2=L.

$$IPRTLIM = \frac{A}{RPRTLIM(\Omega)} (A) \quad A = 8750$$

PRTLFLG(OUTPUT)	Actuator output (FCO/TKO/TLO)
H	OFF
L	active

	MIN.	TYP.	MAX.	Unit
Time until protection function operates	1.0	1.2	1.4	s

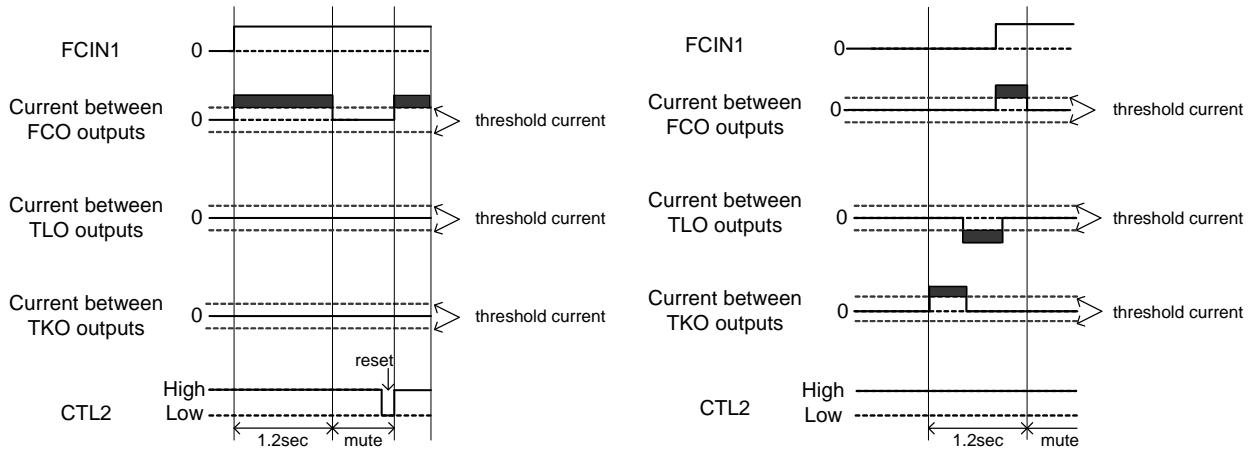

7. Protect system 2

Function to protect against destruction of output terminal when output pin connects to GND or Vcc.

PRTLFLG(OUTPUT)	Spindle, Sled motor driver output
H	OFF
L	active

- Spindle, Sled motor
- When SINK side POWER transistor has been turned on, if the output voltage (SPVM/2&SLVM/2<TYP> or more) are detected, the channel concerned will be turned off.
- When SOURCE side POWER transistor has been turned on, if the output voltage (SPVM/2&SLVM/2<TYP> or less) are detected, the channel concerned will be turned off.

## 8. Inner detection function

BEMF of the motor is monitored according to timing for the sled input signal to pass VC, and Sled is detected reaching the inner. The judgment voltage of BEMF can be set according to the voltage input to the terminal SLDET. If BEMF below the judgment voltage is detected twice continuously, it becomes SLDETOUT=L. The inner detection function can be turned off with SLDET<0.5V. When the motor starts, the terminal SLDETOUT might become L because BEMF is unstable. Please take measures such as installing the time of the mask when it starts for the detection prevention.

$$\text{Judgment voltage } V_{\text{bemf}} = 2.1 \times (\text{SLDET} - \text{VC}) + 0.49$$

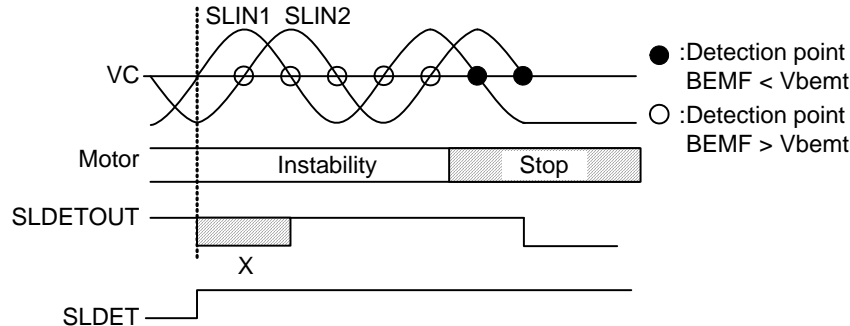

## 9. PWM oscillation frequency

The PWM oscillation for driving the spindle and sled is free running.

The sled and SA oscillating frequency is 100kHz (Typ.)

The spindle oscillating frequency is 167kHz (Typ.)

## 10. Muting functions

## a) VC-drop muting

When the voltage at VC terminal drops to a value lower than 0.7V (Typ.), the outputs of all the channels are turned off. Set the VC terminal voltage higher than 1.0V.

## b) Vcc-drop muting

When the voltage at DVcc terminal and Vcc terminal drop to lower than 3.85V (Typ.), the outputs of all the channels are turned off.

## c) Over voltage protection circuit

When the voltage at SPVM terminal exceed 14.1V (Typ.), only the spindle block output is turned off.

## 11. Thermal-shut down

Thermal-shutdown circuit (over-temperature protection circuit) is built in to prevent the IC from thermal breakdown. Use the IC according to the thermal loss allowed in the package. In case the IC is left running over the allowed loss, the junction temperature rises, and the thermal-shutdown circuit works at a junction temperature of 175°C(Typ.) (All other channel outputs are turned off)

When the junction temperature drops to 150°C (Typ.) the IC resumes operation.

## ●Notes for use

1. Absolute maximum ratings  
We are careful enough for quality control about this IC. So, there is no problem under normal operation, excluding that it exceeds the absolute maximum ratings. However, this IC might be destroyed when the absolute maximum ratings, such as impressed voltages (Vcc, PVcc) or the operating temperature range(Topr), is exceeded, and whether the destruction is short circuit mode or open circuit mode cannot be specified. Please take into consideration the physical countermeasures for safety, such as fusing, if a particular mode that exceeds the absolute maximum rating is assumed.
2. Power supply line  
Due to switching and EMI noise generated by magnetic components (inductors and motors), using electrolytic and ceramic suppress filter capacitors(0.1μF) close to the IC power input terminals (Vcc and GND) is recommended. Please note: the electrolytic capacitor value decreases at lower temperatures. Current rush might flow momentarily by the order of turning on the power supply and the delay in IC with two or more power supplies. Note the capacity of the power supply coupling, width and drawing the power supply and the GND pattern wiring. Please make the power supply lines (where large current flow) wide enough to reduce the resistance of the power supply patterns, because the resistance of power supply pattern might influence the usual operation (output dynamic range etc...).
3. GND line  
The ground line is where the lowest potential and transient voltages are connected to the IC.
4. Thermal design  
Do not exceed the power dissipation (Pd) of the package specification rating under actual operation, and please design enough temperature margins.
5. Short circuit mode between terminals and wrong mounting  
Do not mount the IC in the wrong direction and be careful about the reverse-connection of the power connector. Moreover, this IC might be destroyed when the dust short the terminals between them or GND
6. Radiation  
Strong electromagnetic radiation can cause operation failures.
7. ASO(Area of Safety Operation.)  
Do not exceed the maximum ASO and the absolute maximum ratings of the output driver.
8. TSD(Thermal shut-down)  
The TSD is activated when the junction temperature (Tj) reaches 175°C(with 25°C hysteresis), and the output terminal is switched to Hi-z. The TSD circuit aims to intercept IC from high temperature. The guarantee and protection of IC are not purpose. Therefore, please do not use this IC after TSD circuit operates, nor use it for assumption that operates the TSD circuit.
9. Inspection by the set circuit board  
The stress might hang to IC by connecting the capacitor to the terminal with low impedance. Then, please discharge electricity in each and all process. Moreover, in the inspection process, please turn off the power before mounting the IC, and turn on after mounting the IC. In addition, please take into consideration the countermeasures for electrostatic damage, such as giving the earth in assembly process, transportation or preservation.

## 10. Earth wiring pattern

This IC is a monolithic IC, and has P<sup>+</sup> isolation and P substrate for the element separation. Therefore, a parasitic PN junction is formed in this P-layer and N-layer of each element. For instance, the resistor or the transistor is connected to the terminal as shown in the figure below. When the GND voltage potential is greater than the voltage potential at Terminals A or B, the PN junction operates as a parasitic diode. In addition, the parasitic NPN transistor is formed in said parasitic diode and the N layer of surrounding elements close to said parasitic diode. These parasitic elements are formed in the IC because of the voltage relation. The parasitic element operating causes the wrong operation and destruction. Therefore, please be careful so as not to operate the parasitic elements by impressing to input terminals lower voltage than GND (P substrate). Please do not apply the voltage to the input terminal when the power-supply voltage is not impressed. Moreover, please impress each input terminal lower than the power-supply voltage or equal to the specified range in the guaranteed voltage when the power-supply voltage is impressing.

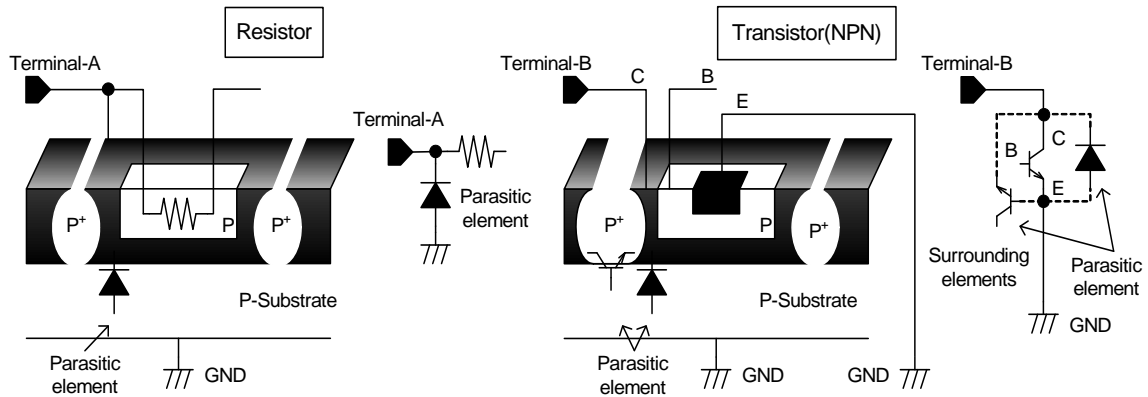

Simplified structure of IC

## 11. Earth wiring pattern

Use separate ground lines for control signals and high current power driver outputs. Because these high current outputs that flows to the wire impedance changes the GND voltage for control signal. Therefore, each ground terminal of IC must be connected at the one point on the set circuit board. As for GND of external parts, it is similar to the above-mentioned.

## 12. Reverse-rotation braking

In the case of reverse-rotation braking from high speed rotation, pay good attention to reverse electromotive force. Furthermore, fully check the voltage to be applied to the output terminal and consider the revolutions applied to the reverse-rotation brake.

## 13. About the capacitor between SPVM and SPGND

The capacitor between SPVM and SPGND absorbs the change in a steep voltage and the current because of the PWM drive, as a result, there is a role to suppress the disorder of the SPVM voltage. However, the effect falls by the influence of the wiring impedance etc, if the capacitor becomes far from IC. Please examine the capacitor between SPVM and SPGND to arrange it near IC.

● Application circuit

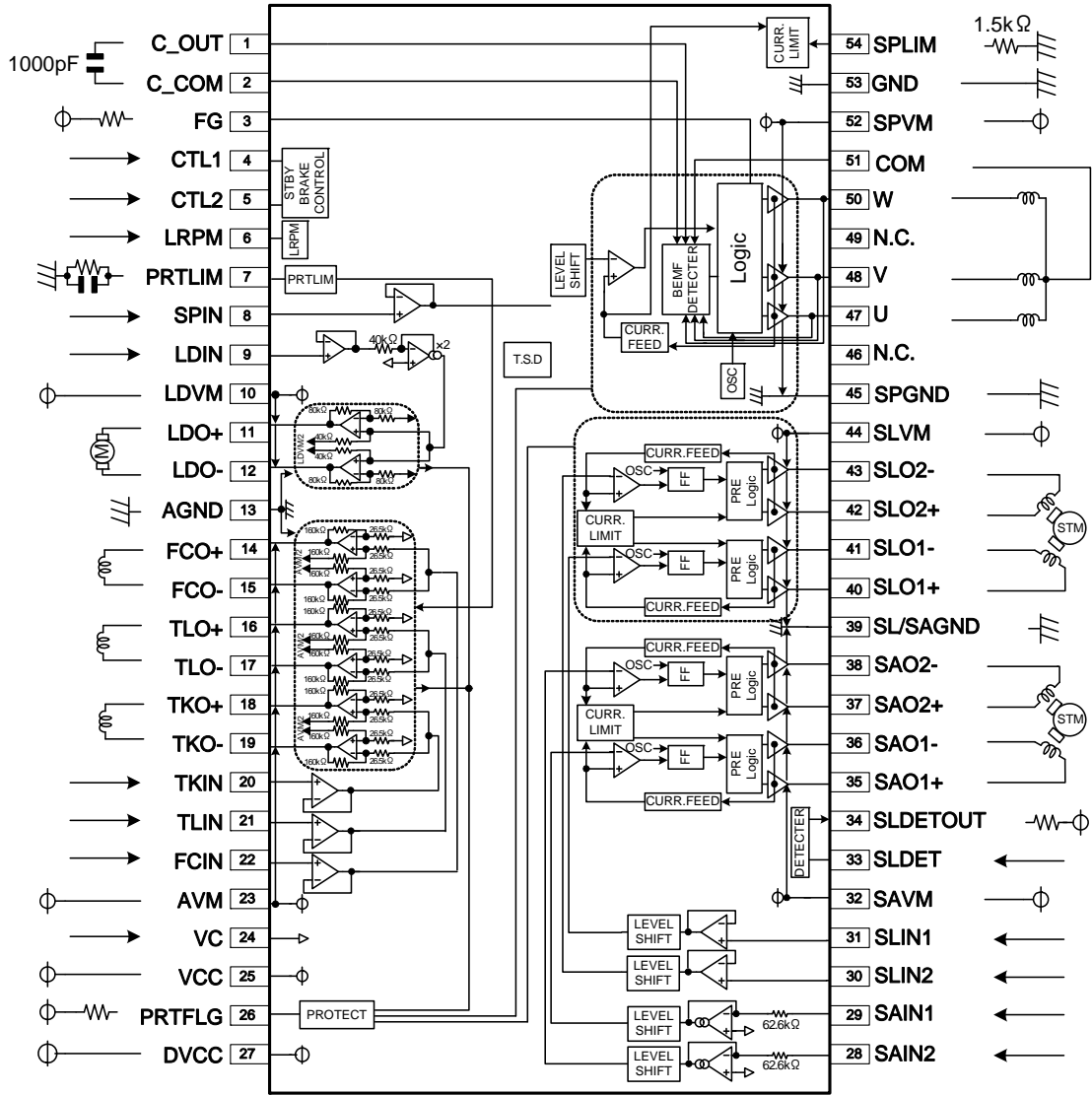

●Connecting wires of application board

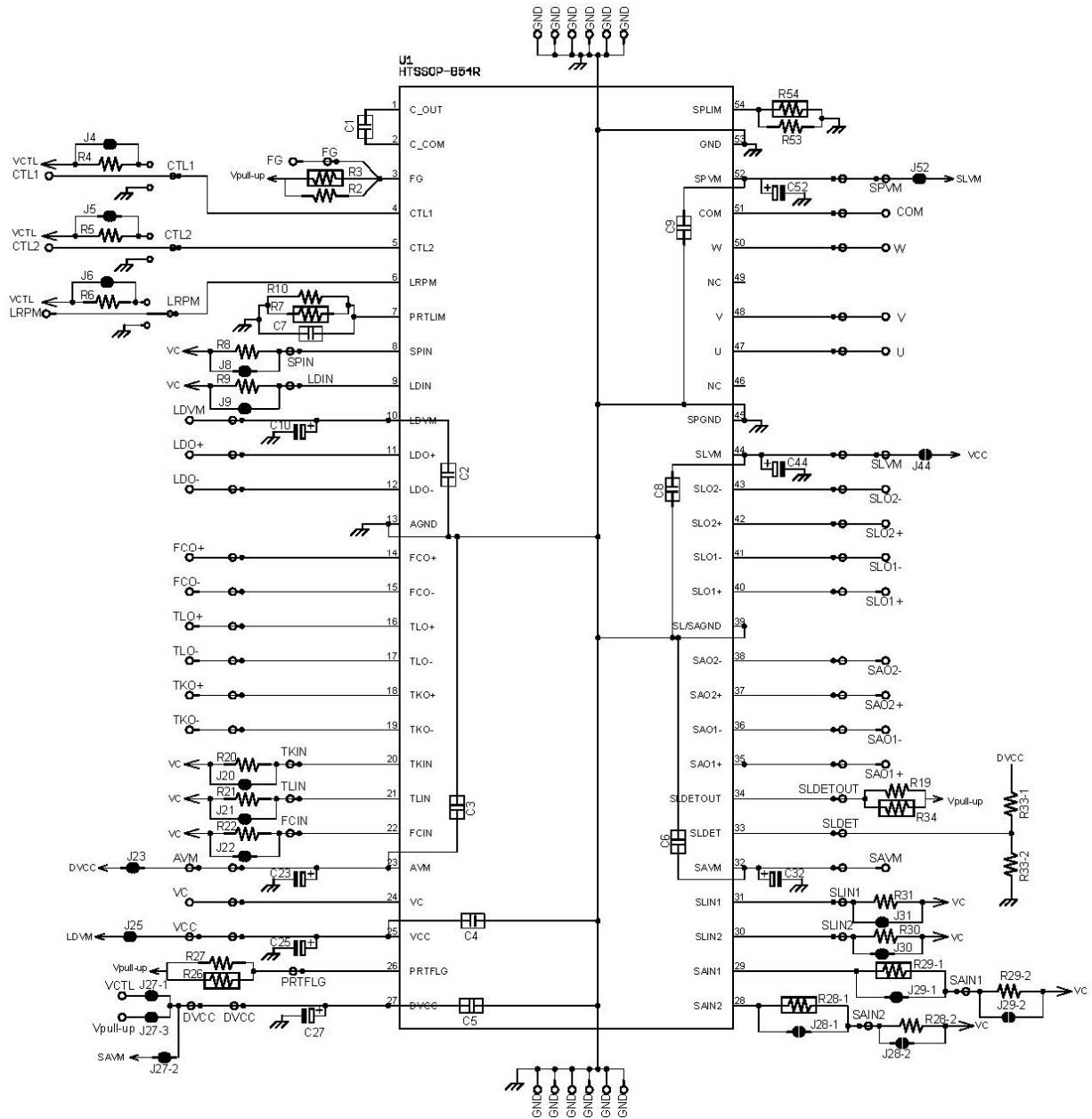

●Pattern drawing of application board

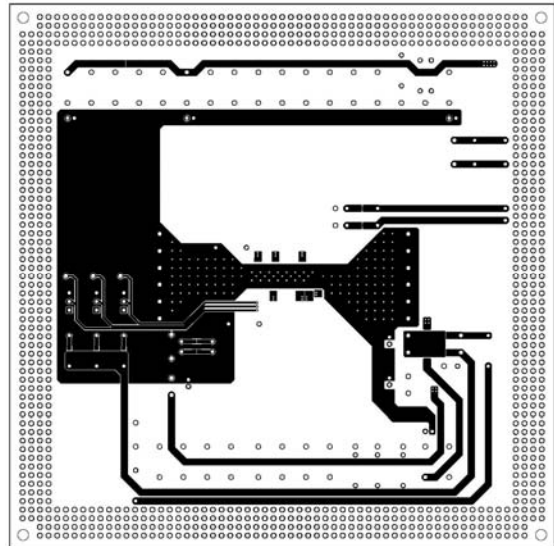
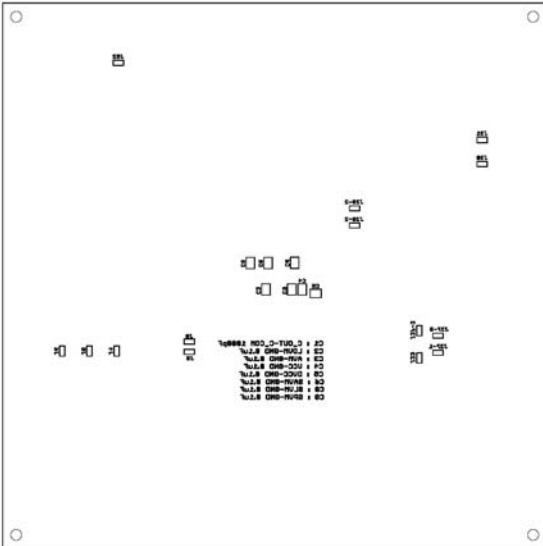
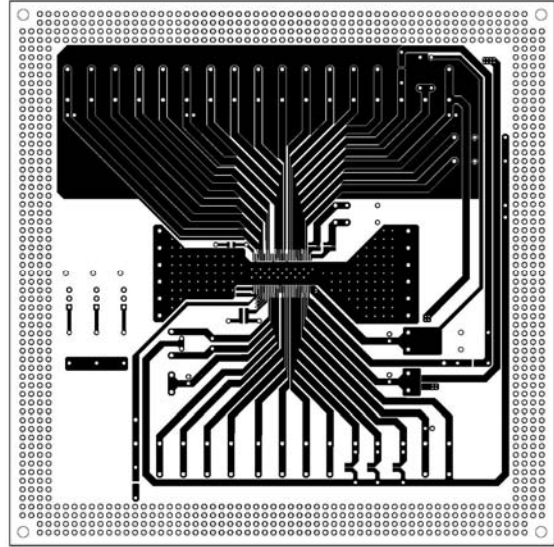
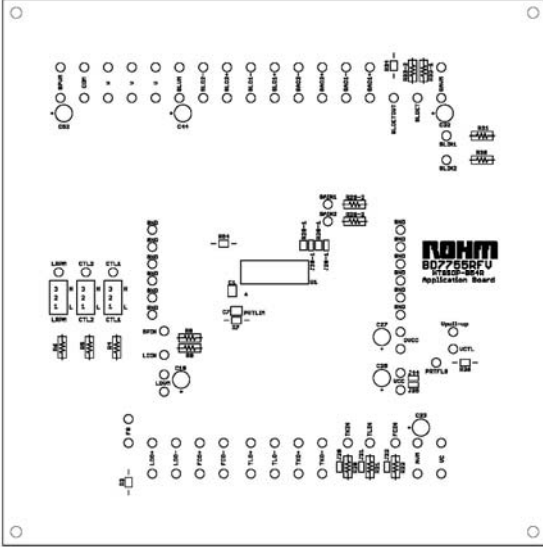

●Power dissipation reduction

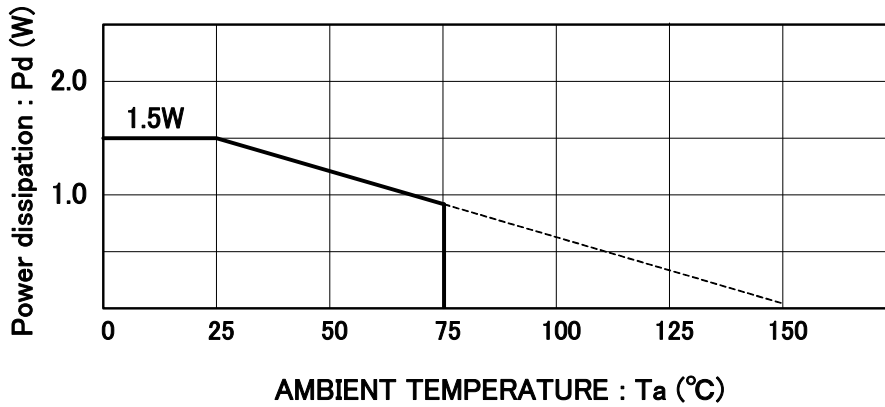

\*70mm × 70mm, t=1.6mm, occupied copper foil is less than 3%, glass epoxy mounting.

●Ordering part number

B	D
---	---

Part No.

7	7	5	5
---	---	---	---

Part No.  
7755

R	F	V
---	---	---

Package  
RFV: HTSSOP-B54R

E	2
---	---

Packaging and forming specification  
E2: Embossed tape and reel  
(HTSSOP-B54R)

HTSSOP-B54R

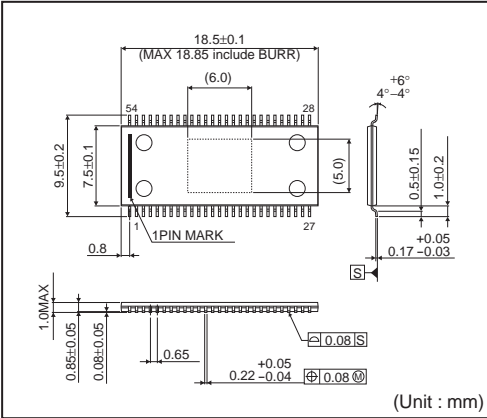

<Tape and Reel information>

Tape	Embossed carrier tape (with dry pack)
Quantity	1500pcs
Direction of feed	E2 (The direction is the 1pin of product is at the upper left when you hold reel on the left hand and you pull out the tape on the right hand)

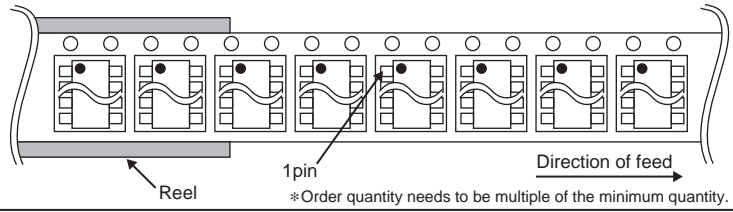

# Notice

## Precaution on using ROHM Products

- Our Products are designed and manufactured for application in ordinary electronic equipments (such as AV equipment, OA equipment, telecommunication equipment, home electronic appliances, amusement equipment, etc.). If you intend to use our Products in devices requiring extremely high reliability (such as medical equipment <sup>(Note 1)</sup>, transport equipment, traffic equipment, aircraft/spacecraft, nuclear power controllers, fuel controllers, car equipment including car accessories, safety devices, etc.) and whose malfunction or failure may cause loss of human life, bodily injury or serious damage to property ("Specific Applications"), please consult with the ROHM sales representative in advance. Unless otherwise agreed in writing by ROHM in advance, ROHM shall not be in any way responsible or liable for any damages, expenses or losses incurred by you or third parties arising from the use of any ROHM's Products for Specific Applications.

(Note1) Medical Equipment Classification of the Specific Applications

JAPAN	USA	EU	CHINA
CLASS III	CLASS III	CLASS II b	CLASS III
CLASS IV		CLASS III	

- ROHM designs and manufactures its Products subject to strict quality control system. However, semiconductor products can fail or malfunction at a certain rate. Please be sure to implement, at your own responsibilities, adequate safety measures including but not limited to fail-safe design against the physical injury, damage to any property, which a failure or malfunction of our Products may cause. The following are examples of safety measures:
  - Installation of protection circuits or other protective devices to improve system safety
  - Installation of redundant circuits to reduce the impact of single or multiple circuit failure
- Our Products are designed and manufactured for use under standard conditions and not under any special or extraordinary environments or conditions, as exemplified below. Accordingly, ROHM shall not be in any way responsible or liable for any damages, expenses or losses arising from the use of any ROHM's Products under any special or extraordinary environments or conditions. If you intend to use our Products under any special or extraordinary environments or conditions (as exemplified below), your independent verification and confirmation of product performance, reliability, etc. prior to use, must be necessary:
  - Use of our Products in any types of liquid, including water, oils, chemicals, and organic solvents
  - Use of our Products outdoors or in places where the Products are exposed to direct sunlight or dust
  - Use of our Products in places where the Products are exposed to sea wind or corrosive gases, including Cl<sub>2</sub>, H<sub>2</sub>S, NH<sub>3</sub>, SO<sub>2</sub>, and NO<sub>2</sub>
  - Use of our Products in places where the Products are exposed to static electricity or electromagnetic waves
  - Use of our Products in proximity to heat-producing components, plastic cords, or other flammable items
  - Sealing or coating our Products with resin or other coating materials
  - Use of our Products without cleaning residue of flux (even if you use no-clean type fluxes, cleaning residue of flux is recommended); or Washing our Products by using water or water-soluble cleaning agents for cleaning residue after soldering
  - Use of the Products in places subject to dew condensation
- The Products are not subject to radiation-proof design.
- Please verify and confirm characteristics of the final or mounted products in using the Products.
- In particular, if a transient load (a large amount of load applied in a short period of time, such as pulse. is applied, confirmation of performance characteristics after on-board mounting is strongly recommended. Avoid applying power exceeding normal rated power; exceeding the power rating under steady-state loading condition may negatively affect product performance and reliability.
- De-rate Power Dissipation (Pd) depending on Ambient temperature (Ta). When used in sealed area, confirm the actual ambient temperature.
- Confirm that operation temperature is within the specified range described in the product specification.
- ROHM shall not be in any way responsible or liable for failure induced under deviant condition from what is defined in this document.

## Precaution for Mounting / Circuit board design

- When a highly active halogenous (chlorine, bromine, etc.) flux is used, the residue of flux may negatively affect product performance and reliability.
- In principle, the reflow soldering method must be used; if flow soldering method is preferred, please consult with the ROHM representative in advance.

For details, please refer to ROHM Mounting specification

### Precautions Regarding Application Examples and External Circuits

1. If change is made to the constant of an external circuit, please allow a sufficient margin considering variations of the characteristics of the Products and external components, including transient characteristics, as well as static characteristics.
2. You agree that application notes, reference designs, and associated data and information contained in this document are presented only as guidance for Products use. Therefore, in case you use such information, you are solely responsible for it and you must exercise your own independent verification and judgment in the use of such information contained in this document. ROHM shall not be in any way responsible or liable for any damages, expenses or losses incurred by you or third parties arising from the use of such information.

### Precaution for Electrostatic

This Product is electrostatic sensitive product, which may be damaged due to electrostatic discharge. Please take proper caution in your manufacturing process and storage so that voltage exceeding the Products maximum rating will not be applied to Products. Please take special care under dry condition (e.g. Grounding of human body / equipment / solder iron, isolation from charged objects, setting of ionizer, friction prevention and temperature / humidity control).

### Precaution for Storage / Transportation

1. Product performance and soldered connections may deteriorate if the Products are stored in the places where:
  - [a] the Products are exposed to sea winds or corrosive gases, including Cl<sub>2</sub>, H<sub>2</sub>S, NH<sub>3</sub>, SO<sub>2</sub>, and NO<sub>2</sub>
  - [b] the temperature or humidity exceeds those recommended by ROHM
  - [c] the Products are exposed to direct sunshine or condensation
  - [d] the Products are exposed to high Electrostatic
2. Even under ROHM recommended storage condition, solderability of products out of recommended storage time period may be degraded. It is strongly recommended to confirm solderability before using Products of which storage time is exceeding the recommended storage time period.
3. Store / transport cartons in the correct direction, which is indicated on a carton with a symbol. Otherwise bent leads may occur due to excessive stress applied when dropping of a carton.
4. Use Products within the specified time after opening a humidity barrier bag. Baking is required before using Products of which storage time is exceeding the recommended storage time period.

### Precaution for Product Label

QR code printed on ROHM Products label is for ROHM's internal use only.

### Precaution for Disposition

When disposing Products please dispose them properly using an authorized industry waste company.

### Precaution for Foreign Exchange and Foreign Trade act

Since our Products might fall under controlled goods prescribed by the applicable foreign exchange and foreign trade act, please consult with ROHM representative in case of export.

### Precaution Regarding Intellectual Property Rights

1. All information and data including but not limited to application example contained in this document is for reference only. ROHM does not warrant that foregoing information or data will not infringe any intellectual property rights or any other rights of any third party regarding such information or data. ROHM shall not be in any way responsible or liable for infringement of any intellectual property rights or other damages arising from use of such information or data.:
2. No license, expressly or implied, is granted hereby under any intellectual property rights or other rights of ROHM or any third parties with respect to the information contained in this document.

### Other Precaution



1. This document may not be reprinted or reproduced, in whole or in part, without prior written consent of ROHM.
2. The Products may not be disassembled, converted, modified, reproduced or otherwise changed without prior written consent of ROHM.
3. In no event shall you use in any way whatsoever the Products and the related technical information contained in the Products or this document for any military purposes, including but not limited to, the development of mass-destruction weapons.
4. The proper names of companies or products described in this document are trademarks or registered trademarks of ROHM, its affiliated companies or third parties.

**General Precaution**

1. Before you use our Products, you are requested to carefully read this document and fully understand its contents. ROHM shall not be in any way responsible or liable for failure, malfunction or accident arising from the use of any ROHM's Products against warning, caution or note contained in this document.
2. All information contained in this document is current as of the issuing date and subject to change without any prior notice. Before purchasing or using ROHM's Products, please confirm the latest information with a ROHM sales representative.
3. The information contained in this document is provided on an "as is" basis and ROHM does not warrant that all information contained in this document is accurate and/or error-free. ROHM shall not be in any way responsible or liable for any damages, expenses or losses incurred by you or third parties resulting from inaccuracy or errors of or concerning such information.

## Looking for pricing, stock, or lifecycle information?

Click below to explore more details on WIN SOURCE:

-  [View BD7755RFV-E2 on WIN SOURCE](#)
-  [Rohm Semiconductor](#) Information

## Optimize Your Supply Chain with WIN SOURCE Solutions

-  Global Sourcing Solution
-  Obsolete Management
-  Cost Control Management
-  Shortage Management
-  Alternative Solution
-  Excess Inventory Management