

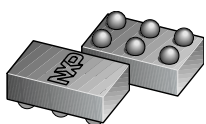

**THE DATASHEET OF
LD6938CX6/1833PLJ**





LD6938 series

Dual low-dropout regulators, low noise, 300 mA

Rev. 1 — 11 July 2013

Objective data sheet

1. Product profile

1.1 General description

The LD6938 series consists of small-size dual Low DropOut regulators (LDO). Each device delivers two times 300 mA with a typical voltage drop of 240 mV at full output load. The devices offer two separate fixed nominal output voltages ($V_{O(nom)}$) in the range of 1.2 V to 3.3 V.

The LDO has an integrated Soft start to control the inrush current during start-up. The output mode, when disabled, can be high-ohmic 3-state or auto discharge. Optionally a delayed start-up circuit is available for the second output. The devices are available in a 6-bump Wafer-Level Chip-Scale Package (WLCSP) with a height of 0.47 mm.

1.2 Features and benefits

- High Power Supply Rejection Ratio (PSRR)
- Low output noise
- Low quiescent current
- Extremely low standby current ($\leq 0.1 \mu\text{A}$)
- Soft start circuit to limit inrush current
- Output current limiter with foldback circuit
- Overtemperature protection
- Delayed output circuit for second LDO (optional)
- Auto discharge or high-ohmic mode for output when disabled
- WLCSP6 with 0.4 mm pitch and package size of 1.2 mm \times 0.8 mm \times 0.47 mm

1.3 Applications

- Smartphones
- Mobile handsets
- Digital still cameras
- Tablet PCs
- Mobile internet devices
- Portable media players

1.4 Quick reference data

- $I_O = 300 \text{ mA}$ for each LDO
- PSRR = 80 dB at 1 kHz
- RMS noise $V_{n(o)RMS} = 70 \mu\text{V}$ at 10 Hz to 100 kHz
- $t_{startup(reg)} \leq 200 \mu\text{s}$
- $V_I = 1.7 \text{ V to } 5.5 \text{ V}$
- $V_O = 1.2 \text{ V to } 3.3 \text{ V}$ (fixed value)
- Drop voltage $V_{do} = 240 \text{ mV}$ at $I_O = 300 \text{ mA}$
- Quiescent current $I_q = 30 \mu\text{A}$ for each LDO at $I_O = 0 \text{ mA}$



2. Pinning information

2.1 Pinning

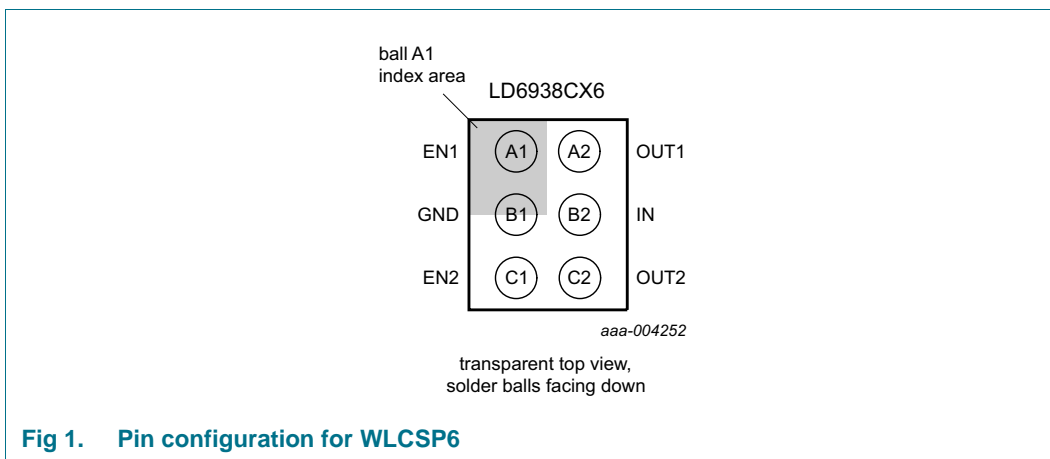

Fig 1. Pin configuration for WLCSP6

2.2 Pin description

Table 1. Pin description for WLCSP6

Symbol	Pin	Description
EN1	A1	regulator 1 enable input
OUT1	A2	regulator 1 output voltage
GND	B1	supply ground
IN	B2	supply voltage input
EN2	C1	regulator 2 enable input
OUT2	C2	regulator 2 output voltage

3. Ordering information

Table 2. Ordering information

Type number	Package		
	Name	Description	Version
LD6938CX6	WLCSP6	wafer level chip-size package; 6 bumps (2 × 3)	-

3.1 Ordering options

Further output voltage versions and optional delay circuit for the second LDO are available on request; see [Section 15 "Contact information"](#).

Table 3. Type number extension of high ohmic output

Type number	Nominal output voltage $V_{O(nom)}$	
	OUT1	OUT2
LD6938CX6/1818H	1.8 V	1.8 V

Table 4. Type number extension for auto discharge

Type number	Nominal output voltage $V_{O(nom)}$	
	OUT1	OUT2
LD6938CX6/1215PL	1.2 V	1.5 V
LD6938CX6/1218PL	1.2 V	1.8 V
LD6938CX6/18125PL	1.8 V	1.25 V
LD6938CX6/1818PL	1.8 V	1.8 V
LD6938CX6/1833PL	1.8 V	3.3 V
LD6938CX6/285285PL	2.85 V	2.85 V
LD6938CX6/3018PL	3.0 V	1.8 V
LD6938CX6/3030PL	3.0 V	3.0 V
LD6938CX6/33285PL	3.3 V	2.85 V
LD6938CX6/3333PL	3.3 V	3.3 V

4. Block diagram

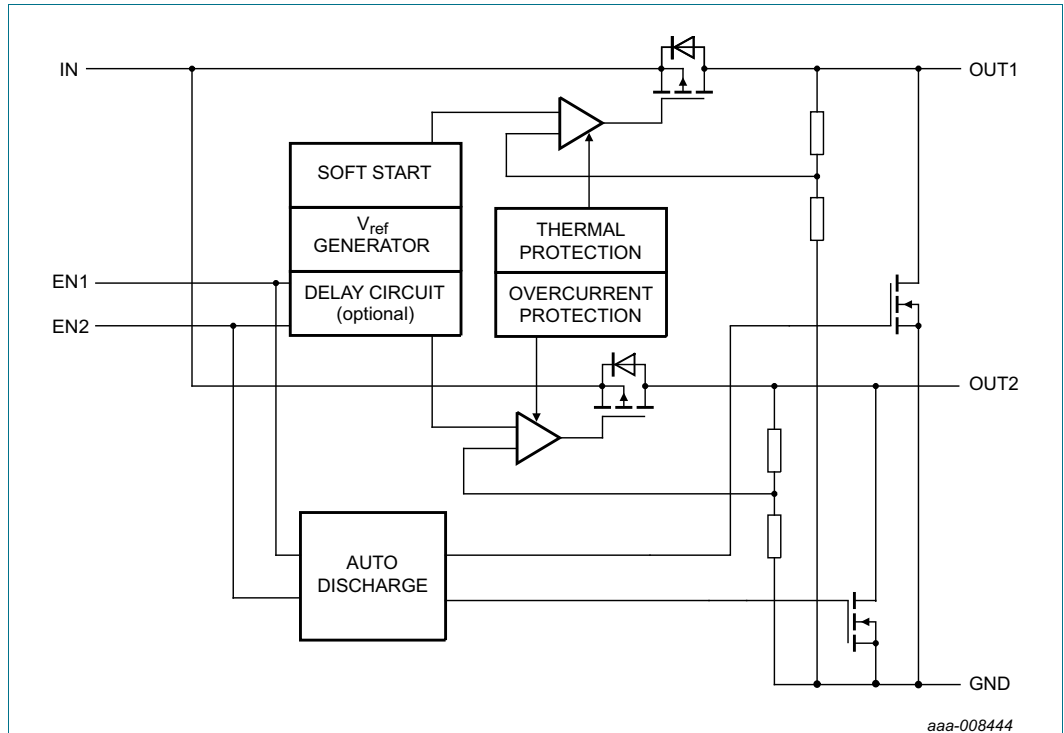

Fig 2. Block diagram dual LDO with auto discharge function (-PL version)

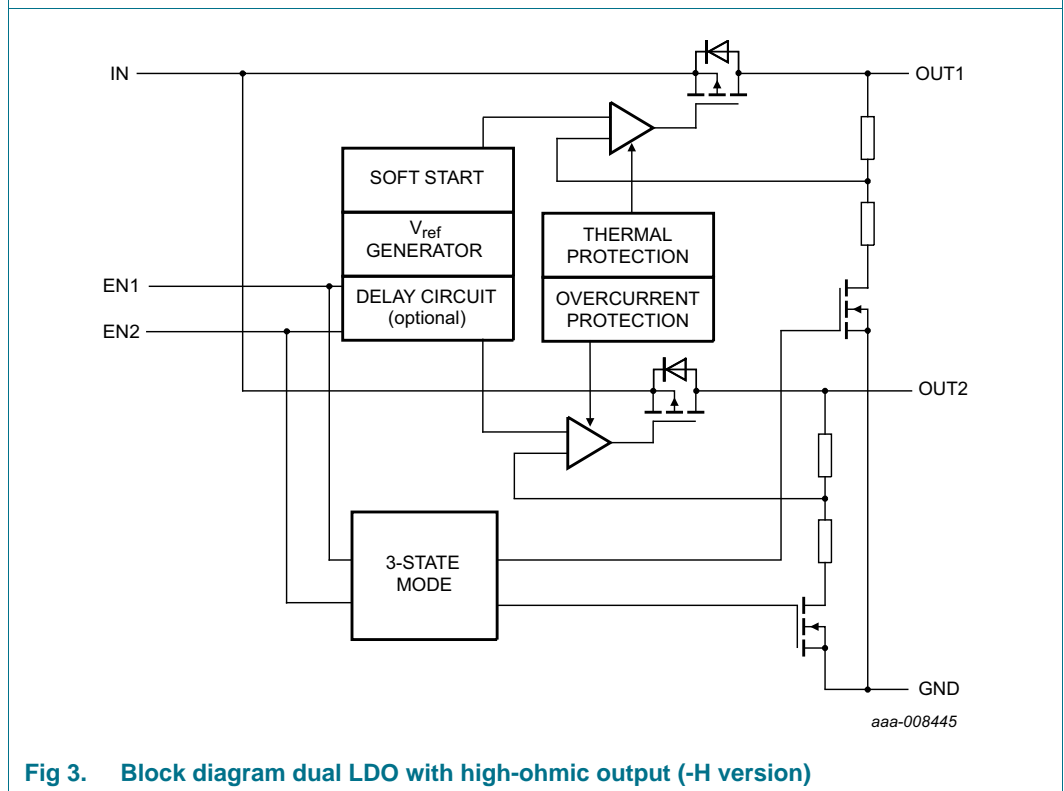

Fig 3. Block diagram dual LDO with high-ohmic output (-H version)

5. Limiting values

Table 5. Limiting values

In accordance with the Absolute Maximum Rating System (IEC 60134). Voltages are referenced to GND (ground = 0 V).

Symbol	Parameter	Conditions	Min	Max	Unit
T_{stg}	storage temperature		-55	+150	°C
T_j	junction temperature		-40	+125	°C
T_{amb}	ambient temperature		-40	+85	°C
P_{tot}	total power dissipation		[1] -	1000	mW
V_{ESD}	electrostatic discharge voltage	human body model level 4	[2] -	±2	kV
		machine model class 3	[3] -	±200	V
Pin IN, EN1 and EN2					
V_I	input voltage	4 ms transient	-0.5	+6.0	V
V_{EN}	voltage on pin EN	4 ms transient	-0.5	+6.0	V
Pin OUT1 and OUT2					
V_O	output voltage	4 ms transient	-0.5	+6.0	V
I_O	output current		0	500	mA

[1] The (absolute) maximum power dissipation depends on the junction temperature T_j . Higher power dissipation is allowed with lower ambient temperatures. The conditions to determine the specified values are $T_{amb} = 25$ °C and the use of a two-layer Printed-Circuit Board (PCB).

[2] According to IEC 61340-3-1.

[3] According to JESD22-A115C.

6. Recommended operating conditions

Table 6. Operating conditions

Voltages are referenced to GND (ground = 0 V).

Symbol	Parameter	Conditions	Min	Max	Unit
T_{amb}	ambient temperature		-40	+85	°C
T_j	junction temperature		-	+125	°C
Pin IN					
V_I	input voltage		1.7	5.5	V
$C_{ext(IN)}$	external capacitance on pin IN		[1] 1.0	-	µF
Pin EN1 and EN2					
V_{EN}	voltage on pin EN		0	V_I	V
Pin OUT1 and OUT2					
V_O	output voltage		0	5.5	V
$C_{L(ext)}$	external load capacitance		[1] 1.0	-	µF

[1] See [Section 9.1 "Input and output capacitor values"](#).

7. Thermal characteristics

Table 7. Thermal characteristics

Symbol	Parameter	Conditions	Typ	Unit
$R_{th(j-a)}$	thermal resistance from junction to ambient		[1][2] 100	K/W

- [1] The overall $R_{th(j-a)}$ can vary depending on the board layout. To minimize the effective $R_{th(j-a)}$, all pins must have a solid connection to larger Cu layer areas for example to the power and ground layer. In multi-layer PCB applications, the second layer should be used to create a large heat spreader area directly below the LDO. If this layer is either ground or power, it should be connected with several vias to the top layer connecting to the device ground or supply. Avoid the use of solder-stop varnish under the chip.
- [2] Use the measurement data given for a rough estimation of the $R_{th(j-a)}$ in your application. The actual $R_{th(j-a)}$ value can vary in applications using different layer stacks and layouts.

8. Characteristics

Table 8. Electrical characteristics

At recommended input voltages and $T_{amb} = -40\text{ °C}$ to $+85\text{ °C}$; voltages are referenced to GND (ground = 0 V); unless otherwise specified.

Symbol	Parameter	Conditions	Min	Typ	Max	Unit
Output voltage (pin OUT1 and OUT2)						
V_{do}	dropout voltage	$I_O = 300\text{ mA}; V_{IN} \leq V_{O(nom)}$	-	240	400	mV
ΔV_O	output voltage variation	$V_O \geq 1.5\text{ V}; I_O = 1\text{ mA}$				
		$T_{amb} = +25\text{ °C}$	-2	-	+2	%
		$-30\text{ °C} \leq T_{amb} \leq +85\text{ °C}$	-3	-	+3	%
		$V_O < 1.5\text{ V}; I_O = 1\text{ mA}$				
		$T_{amb} = +25\text{ °C}$	-3	-	+3	%
		$-30\text{ °C} \leq T_{amb} \leq +85\text{ °C}$	-4	-	+4	%
Line regulation error						
$\Delta V_O / (V_O \times \Delta V_I)$	relative output voltage variation with input voltage	$V_I = (V_{O(nom)} + 1\text{ V})$ to $5.5\text{ V}; I_O = 1\text{ mA}$	-0.1	-	+0.1	%/V
$\Delta V_O / V_O$	relative output voltage variation	$V_I = (V_{O(nom)} + 1\text{ V})$ to $5.5\text{ V}; I_O = 1\text{ mA}$	-0.33	-	+0.33	%
Load regulation error						
$\Delta V_O / (V_O \times \Delta I_O)$	relative output voltage variation with output current	$V_I = V_{O(nom)} + 1\text{ V}; 1\text{ mA} \leq I_O \leq 300\text{ mA}$	-	0.0025	0.0065	%/mA
$\Delta V_O / V_O$	relative output voltage variation	$V_I = V_{O(nom)} + 1\text{ V}$	-	-	2	%

Table 8. Electrical characteristics ...continued

At recommended input voltages and $T_{amb} = -40\text{ }^{\circ}\text{C}$ to $+85\text{ }^{\circ}\text{C}$; voltages are referenced to GND (ground = 0 V); unless otherwise specified.

Symbol	Parameter	Conditions	Min	Typ	Max	Unit
Output current (pin OUT1 and OUT2)						
I_O	output current		300	-	-	mA
$I_{act(fold)}$	foldback activation current	$V_O = 0.9 \times V_{O(nom)}$	-	750	-	mA
I_{sc}	short-circuit current	$V_O = 0\text{ V}$	-	100	-	mA
I_q	quiescent current	(EN1 or EN2) = HIGH; $I_O = 0\text{ mA}$ at OUT1 and OUT2; $V_I = V_{O(nom)} + 1\text{ V}$	-	30	-	μA
		(EN1 and EN2) = HIGH; $I_O = 0\text{ mA}$ at OUT1 and OUT2; $V_I = V_{O(nom)} + 1\text{ V}$	-	58	75	μA
		(EN1 or EN2) = HIGH; $1\text{ mA} \leq I_O \leq 300\text{ mA}$ at OUT1 and OUT2; $V_I = V_{O(nom)} + 1\text{ V}$	-	400	-	μA
		(EN1 and EN2) = LOW	-	-	1.0	μA
Ripple rejection and output noise						
PSRR	power supply rejection ratio	$V_I = V_{O(nom)} + 1\text{ V}$; $I_O = 50\text{ mA}$; $f_{ripple} = 1\text{ kHz}$; $C_{L(ext)} = 1\text{ }\mu\text{F}$	-	80	-	dB
$V_{n(o)(RMS)}$	RMS output noise voltage	bandwidth = 10 Hz to 100 kHz; $C_{L(ext)} = 1\text{ }\mu\text{F}$; $V_O = 1.8\text{ V}$	-	70	-	μV
Enable input and timing (pin EN1 and EN2)						
V_{IL}	LOW-level input voltage		0	-	0.4	V
V_{IH}	HIGH-level input voltage		1.1	-	5.5	V
I_{en}	enable current	-H version	-	250	-	nA
		-PL version; $V_{EN} = 1.8\text{ V}$	-	12	-	μA
R_{pd}	pull-down resistance	-PL version	100	150	200	k Ω
$t_{startup(reg)}$	regulator start-up time	$V_I = 5.5\text{ V}$; $V_O = 0.95 \times V_{O(nom)}$; $I_O = 300\text{ mA}$; $C_{L(ext)} = 1\text{ }\mu\text{F}$	-	110	200	μs
Automatic discharge function (-PL version)						
R_{pd}	pull-down resistance		-	100	-	Ω
$t_{sd(reg)}$	regulator shutdown time	$V_I = 5.5\text{ V}$; $C_{L(ext)} = 1\text{ }\mu\text{F}$; $I_O = 0\text{ A}$; $V_O = 0.1 \times V_{O(nom)}$	[1]	-	300	μs
Thermal protection						
T_{sd}	shutdown temperature		-	160	-	$^{\circ}\text{C}$
$T_{sd(hys)}$	shutdown temperature hysteresis		[1]	-	20	K

[1] After T_{sd} was reached and after the device was disabled, the junction temperature must decrease by $T_{sd(hys)}$ to enable the device.

9. Application information

9.1 Input and output capacitor values

The devices require external capacitors at the output to guarantee a stable regulator behavior. Also an input capacitor is recommended to keep the input voltage stable. These capacitors should not under-run the specified minimum Equivalent Series Resistance (ESR).

The absolute value of the total capacitance attached to the output pin OUT influences the shutdown time ($t_{sd(reg)}$) of the devices.

Table 9. External load capacitor

Symbol	Parameter	Conditions	Min	Typ	Max	Unit
$C_{ext(IN)}$	external capacitance on pin IN		0.7	1.0	-	μF
$C_{L(ext)}$	external load capacitance	[1]	0.7	1.0	-	μF
ESR	equivalent series resistance		5	-	500	$\text{m}\Omega$

[1] The minimum value of capacitance for stability and correct operation is 0.7 μF . The capacitor tolerance should be $\pm 30\%$ or better over the temperature range. The full range of operating conditions for the capacitor in the application should be considered during device selection to ensure that this minimum capacitance specification is met. The recommended capacitor type is X7R to meet the full device temperature specification of $-40\text{ }^\circ\text{C}$ to $+125\text{ }^\circ\text{C}$.

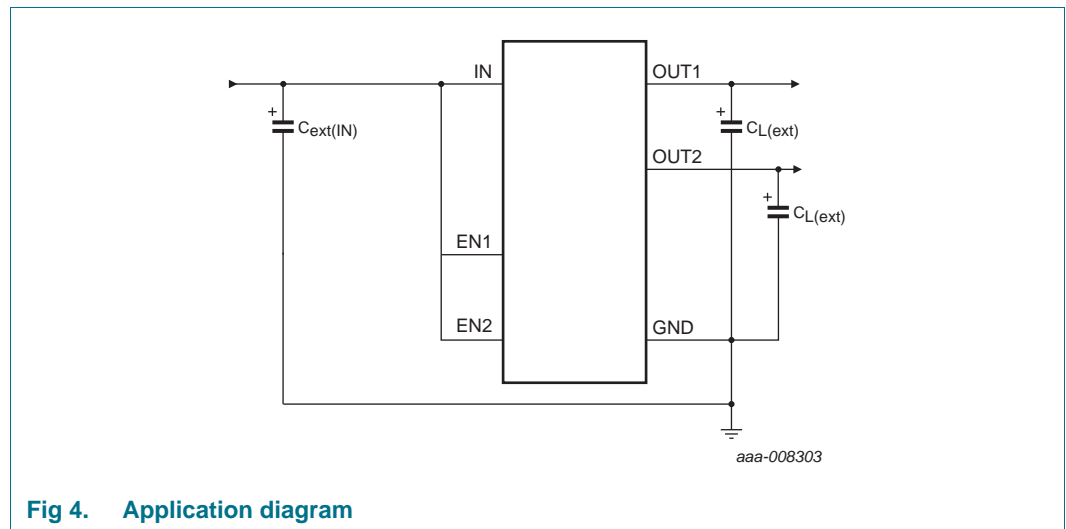

Fig 4. Application diagram

10. Test information

10.1 Quality information

This product has been qualified in accordance with *NX1-00023 NXP Semiconductors Quality and Reliability Specification* and is suitable for use in consumer applications

11. Package outline

WLCSP6: wafer level chip-size package; 6 bumps (2 x 3)

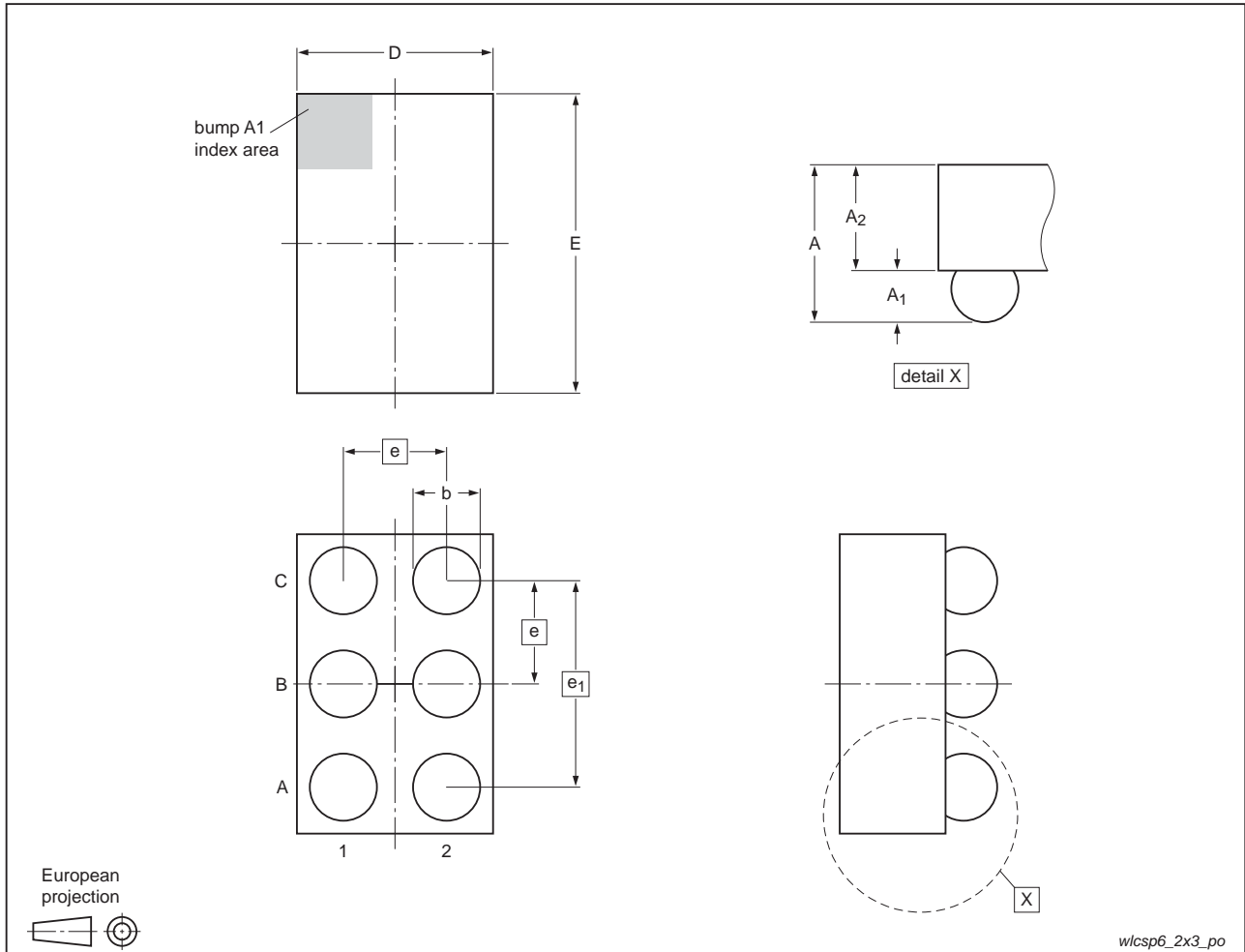

Fig 5. Package outline WLCSP6

Table 10. Dimensions of LD6938 series in WLCSP6 (Figure 5)

Symbol	Min	Typ	Max	Unit
A	0.440	0.470	0.500	mm
A ₁	0.180	0.200	0.220	mm
A ₂	0.260	0.270	0.280	mm
b	0.210	0.260	0.310	mm
D	0.710	0.760	0.810	mm
E	1.110	1.160	1.210	mm
e	-	0.400	-	mm
e ₁	-	0.800	-	mm

12. PCB assembly guidelines for Pb-free soldering

Table 11. Assembly recommendations

Parameter	Value or specification
Solder screen thickness	100 μm (0.004 inch)
Solder paste: Pb-free	SnAg (3 % to 4 %); Cu (0.5 % to 0.9 %)
Solder to flux ratio	50 : 50
Solder reflow profile	see Figure 6

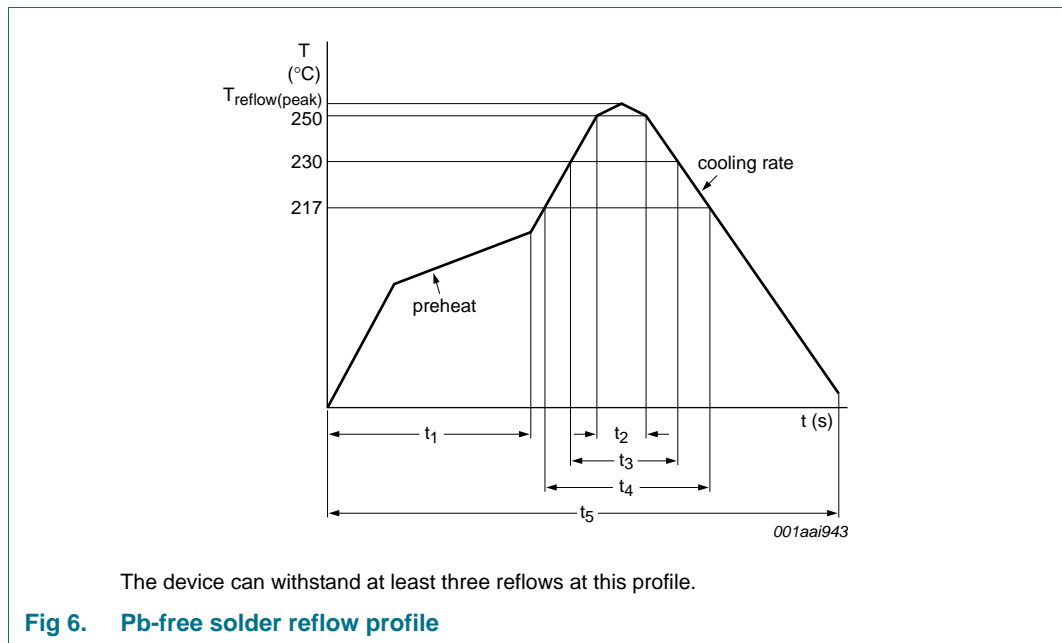

Fig 6. Pb-free solder reflow profile

Table 12. Characteristics

Symbol	Parameter	Conditions	Min	Typ	Max	Unit
$T_{\text{reflow(peak)}}$	peak reflow temperature		230	-	260	°C
t_1	time 1	soak time	60	-	180	s
t_2	time 2	time during $T \geq 250\text{ °C}$	-	-	30	s
t_3	time 3	time during $T \geq 230\text{ °C}$	10	-	50	s
t_4	time 4	time during $T > 217\text{ °C}$	30	-	150	s
t_5	time 5		-	-	540	s
dT/dt	rate of change of temperature	cooling rate	-	-	-6	°C/s
		preheat	2.5	-	4.0	°C/s

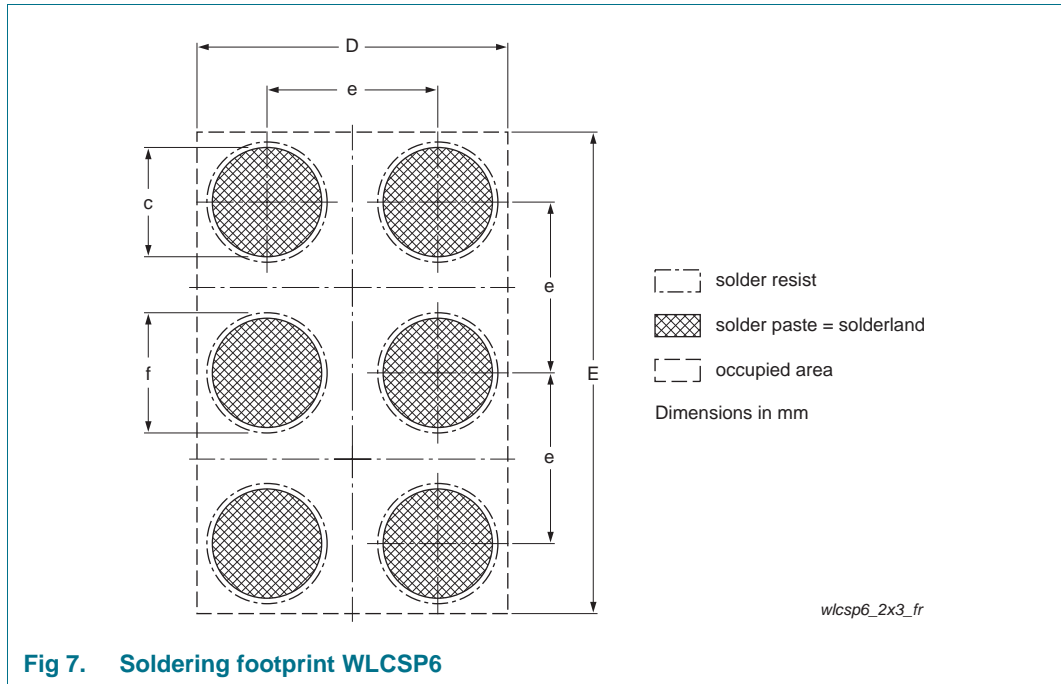

Table 13. Dimensions of soldering footprint WLCSP6 (Figure 7)

Symbol	Min	Typ	Max	Unit
c	-	0.25	-	mm
D	0.71	0.76	0.81	mm
E	1.11	1.16	1.21	mm
e	-	0.4	-	mm
f	-	0.325	-	mm

13. Revision history

Table 14. Revision history

Document ID	Release date	Data sheet status	Change notice	Supersedes
LD6938_SER v.1	20130711	Objective data sheet	-	-

14. Legal information

14.1 Data sheet status

Document status ^{[1][2]}	Product status ^[3]	Definition
Objective [short] data sheet	Development	This document contains data from the objective specification for product development.
Preliminary [short] data sheet	Qualification	This document contains data from the preliminary specification.
Product [short] data sheet	Production	This document contains the product specification.

[1] Please consult the most recently issued document before initiating or completing a design.

[2] The term 'short data sheet' is explained in section "Definitions".

[3] The product status of device(s) described in this document may have changed since this document was published and may differ in case of multiple devices. The latest product status information is available on the Internet at URL <http://www.nxp.com>.

14.2 Definitions

Draft — The document is a draft version only. The content is still under internal review and subject to formal approval, which may result in modifications or additions. NXP Semiconductors does not give any representations or warranties as to the accuracy or completeness of information included herein and shall have no liability for the consequences of use of such information.

Short data sheet — A short data sheet is an extract from a full data sheet with the same product type number(s) and title. A short data sheet is intended for quick reference only and should not be relied upon to contain detailed and full information. For detailed and full information see the relevant full data sheet, which is available on request via the local NXP Semiconductors sales office. In case of any inconsistency or conflict with the short data sheet, the full data sheet shall prevail.

Product specification — The information and data provided in a Product data sheet shall define the specification of the product as agreed between NXP Semiconductors and its customer, unless NXP Semiconductors and customer have explicitly agreed otherwise in writing. In no event however, shall an agreement be valid in which the NXP Semiconductors product is deemed to offer functions and qualities beyond those described in the Product data sheet.

14.3 Disclaimers

Limited warranty and liability — Information in this document is believed to be accurate and reliable. However, NXP Semiconductors does not give any representations or warranties, expressed or implied, as to the accuracy or completeness of such information and shall have no liability for the consequences of use of such information. NXP Semiconductors takes no responsibility for the content in this document if provided by an information source outside of NXP Semiconductors.

In no event shall NXP Semiconductors be liable for any indirect, incidental, punitive, special or consequential damages (including - without limitation - lost profits, lost savings, business interruption, costs related to the removal or replacement of any products or rework charges) whether or not such damages are based on tort (including negligence), warranty, breach of contract or any other legal theory.

Notwithstanding any damages that customer might incur for any reason whatsoever, NXP Semiconductors' aggregate and cumulative liability towards customer for the products described herein shall be limited in accordance with the *Terms and conditions of commercial sale* of NXP Semiconductors.

Right to make changes — NXP Semiconductors reserves the right to make changes to information published in this document, including without limitation specifications and product descriptions, at any time and without notice. This document supersedes and replaces all information supplied prior to the publication hereof.

Suitability for use — NXP Semiconductors products are not designed, authorized or warranted to be suitable for use in life support, life-critical or safety-critical systems or equipment, nor in applications where failure or malfunction of an NXP Semiconductors product can reasonably be expected to result in personal injury, death or severe property or environmental damage. NXP Semiconductors and its suppliers accept no liability for inclusion and/or use of NXP Semiconductors products in such equipment or applications and therefore such inclusion and/or use is at the customer's own risk.

Applications — Applications that are described herein for any of these products are for illustrative purposes only. NXP Semiconductors makes no representation or warranty that such applications will be suitable for the specified use without further testing or modification.

Customers are responsible for the design and operation of their applications and products using NXP Semiconductors products, and NXP Semiconductors accepts no liability for any assistance with applications or customer product design. It is customer's sole responsibility to determine whether the NXP Semiconductors product is suitable and fit for the customer's applications and products planned, as well as for the planned application and use of customer's third party customer(s). Customers should provide appropriate design and operating safeguards to minimize the risks associated with their applications and products.

NXP Semiconductors does not accept any liability related to any default, damage, costs or problem which is based on any weakness or default in the customer's applications or products, or the application or use by customer's third party customer(s). Customer is responsible for doing all necessary testing for the customer's applications and products using NXP Semiconductors products in order to avoid a default of the applications and the products or of the application or use by customer's third party customer(s). NXP does not accept any liability in this respect.

Limiting values — Stress above one or more limiting values (as defined in the Absolute Maximum Ratings System of IEC 60134) will cause permanent damage to the device. Limiting values are stress ratings only and (proper) operation of the device at these or any other conditions above those given in the Recommended operating conditions section (if present) or the Characteristics sections of this document is not warranted. Constant or repeated exposure to limiting values will permanently and irreversibly affect the quality and reliability of the device.

Terms and conditions of commercial sale — NXP Semiconductors products are sold subject to the general terms and conditions of commercial sale, as published at <http://www.nxp.com/profile/terms>, unless otherwise agreed in a valid written individual agreement. In case an individual agreement is concluded only the terms and conditions of the respective agreement shall apply. NXP Semiconductors hereby expressly objects to applying the customer's general terms and conditions with regard to the purchase of NXP Semiconductors products by customer.

No offer to sell or license — Nothing in this document may be interpreted or construed as an offer to sell products that is open for acceptance or the grant, conveyance or implication of any license under any copyrights, patents or other industrial or intellectual property rights.

Export control — This document as well as the item(s) described herein may be subject to export control regulations. Export might require a prior authorization from competent authorities.

Quick reference data — The Quick reference data is an extract of the product data given in the Limiting values and Characteristics sections of this document, and as such is not complete, exhaustive or legally binding.

Non-automotive qualified products — Unless this data sheet expressly states that this specific NXP Semiconductors product is automotive qualified, the product is not suitable for automotive use. It is neither qualified nor tested in accordance with automotive testing or application requirements. NXP Semiconductors accepts no liability for inclusion and/or use of non-automotive qualified products in automotive equipment or applications.

In the event that customer uses the product for design-in and use in automotive applications to automotive specifications and standards, customer (a) shall use the product without NXP Semiconductors' warranty of the product for such automotive applications, use and specifications, and (b) whenever customer uses the product for automotive applications beyond NXP Semiconductors' specifications such use shall be solely at customer's own risk, and (c) customer fully indemnifies NXP Semiconductors for any liability, damages or failed product claims resulting from customer design and use of the product for automotive applications beyond NXP Semiconductors' standard warranty and NXP Semiconductors' product specifications.

14.4 Trademarks

Notice: All referenced brands, product names, service names and trademarks are the property of their respective owners.

15. Contact information

For more information, please visit: <http://www.nxp.com>

For sales office addresses, please send an email to: salesaddresses@nxp.com

16. Contents

1 Product profile 1

1.1 General description 1

1.2 Features and benefits 1

1.3 Applications 1

1.4 Quick reference data 1

2 Pinning information 2

2.1 Pinning 2

2.2 Pin description 2

3 Ordering information 3

3.1 Ordering options 3

4 Block diagram 4

5 Limiting values 5

6 Recommended operating conditions 5

7 Thermal characteristics 6

8 Characteristics 6

9 Application information 8

9.1 Input and output capacitor values 8

10 Test information 8

10.1 Quality information 8

11 Package outline 9

12 PCB assembly guidelines for Pb-free soldering 10

13 Revision history 12

14 Legal information 13

14.1 Data sheet status 13

14.2 Definitions 13

14.3 Disclaimers 13

14.4 Trademarks 14



15 Contact information 14

16 Contents 15

Please be aware that important notices concerning this document and the product(s) described herein, have been included in section 'Legal information'.

Looking for pricing, stock, or lifecycle information?

Click below to explore more details on WIN SOURCE:

-  [View LD6938CX6/1833PLJ on WIN SOURCE](#)
-  [NXP / Nexperia Information](#)

Optimize Your Supply Chain with WIN SOURCE Solutions

-  Global Sourcing Solution
-  Obsolete Management
-  Cost Control Management
-  Shortage Management
-  Alternative Solution
-  Excess Inventory Management