



**THE DATASHEET OF
LMV358QPW**



AN-1298 LM5007 Evaluation Board

1 Introduction

The LM5007 evaluation board is designed to provide the design engineer with a fully functional step down switching regulator to evaluate LM5007 regulator IC, in a typical environment.

The performance of evaluation board is as follows:

- Input range: 12V to 75V
- Output voltage: 10V
- Output current: 400mA
- Measured efficiency: 90% at 300mA and $V_{IN} = 30V$
- Board size: 31.9mm x 44.4mm

2 Theory of Operation

The LM5007 Step down switching regulator features all of the functions needed to implement low cost, efficient, Buck bias regulators. This high voltage regulator contains an 80V, 0.7A N-channel Buck switch. The regulator is based on hysteretic control scheme using an on-time inversely proportional to input voltage (V_{IN}). This feature allows the operating frequency to remain relatively constant with load and input voltage variations. The hysteretic control requires no control loop compensation, while providing fast load transient response. Additional protection features include : Thermal Shutdown, V_{CC} undervoltage lockout and maximum duty-cycle limiter. LM5007 can be used in numerous applications to efficiently regulate step down higher voltage inputs. This regulator is well suited for 48V telecom and the new 42V automotive power bus ranges.

The LM5007 operates in discontinuous conduction mode at light load currents or continuous conduction mode at heavier load currents. In discontinuous conduction mode, current through the output inductor starts at zero and ramps up to the peak value during the buck switch on time, and then back to zero during buck switch off time. In discontinuous conduction mode, the operating frequency can be relatively low and will vary with load. Therefore at light loads the conversion efficiency is maintained , since switching losses decrease with reduction in switching frequency.

The evaluation board just needs one high voltage power-supply (up to 75V and current rating of 1A). The maximum output power is 4 watts. Either an electronic load or resistor bank can be used for testing evaluation board.

3 Start-up Feature

There is no soft-start feature in LM5007, and it normally comes up with full load current to supply the power demanded by the load within a short time. The LM5007 contains an intelligent current limit OFF timer intended to reduce the foldback characteristic inherent with fixed off-time over-current protection. If the current in the Buck FET exceeds 725mA the present cycle is immediately terminated (cycle by cycle current limit). Following the termination of the cycle a non-resetable current limit off timer is initiated. The duration of off time is a function of the external setting resistor (R_{cl}) and the FB pin voltage. When FB pin voltage = 0V the current limit off time is internally preset to 15 μ s. This condition occurs in short circuit operation when a maximum amount of off time is required.

In cases of overload (not complete short circuit) the current limit off time can be reduced as a function of the output voltage (measured at the FB pin). Reducing the off time during smaller overloads reduces the amount of foldback and also reduces the initial start-up time.

All trademarks are the property of their respective owners.

4 Low Ripple Configuration

For applications where lower output voltage ripple is required the output load can be connected directly to the low ESR output capacitor, as shown in Figure 1. The evaluation board is laid out in such a way that, user can use either (high ripple or low ripple) options by simply shifting the output connector. The series resistor (R) will degrade the load regulation however. Another technique for enhancing the ripple voltage at the FB pin is to place a capacitor in parallel with the feedback divider resistor R1. The addition of the capacitor reduces the attenuation of the ripple voltage from the feedback divider.

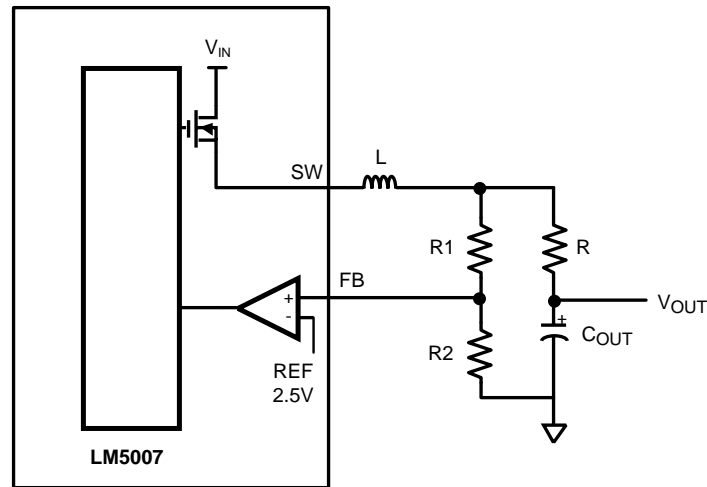

Figure 1. Low Ripple Configuration

5 Schematic

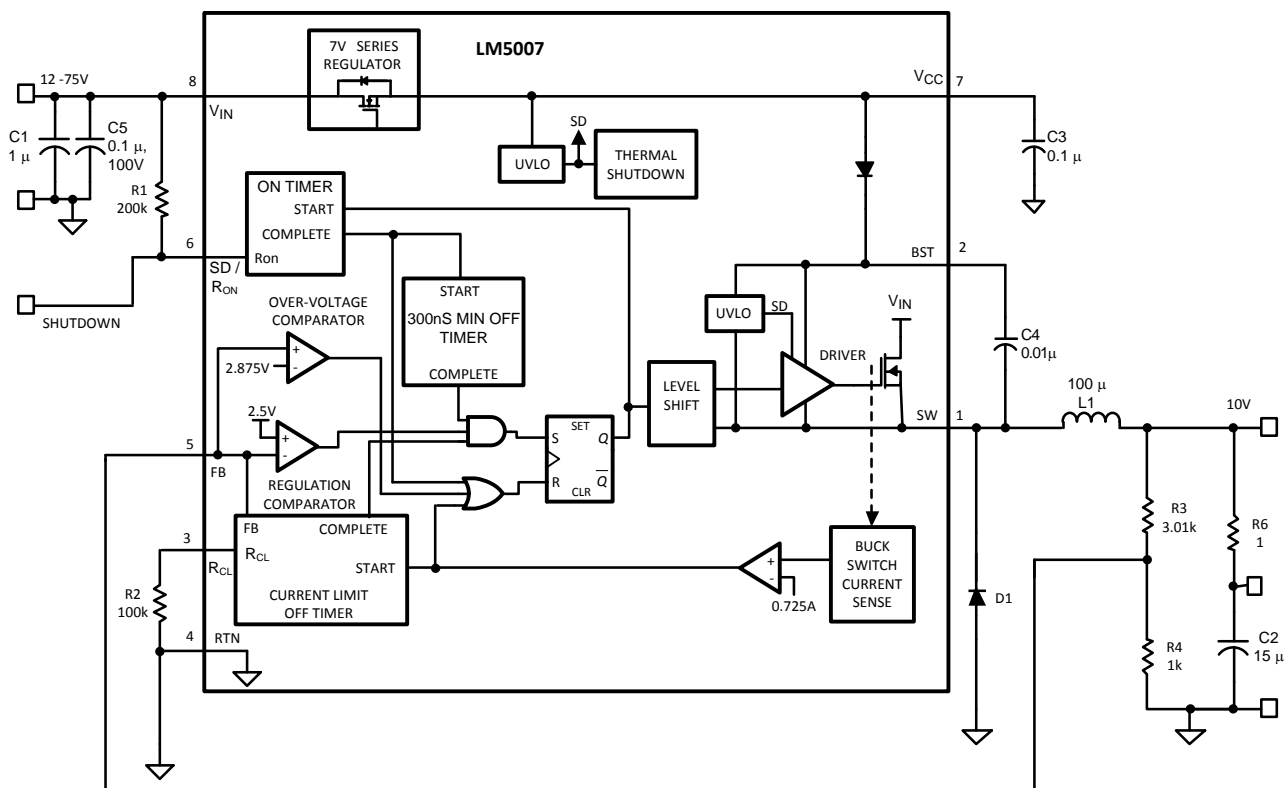

Figure 2. Evaluation Board Schematic Diagram

6 Bill of Materials

Table 1. Bill of Materials

Item	Qty	Part Number	Description	Value
C	1	C4532X7R2A105M	CAPACITOR, CER, TDK	1 μ , 100V
C	2	C4532X7R1E156M	CAPACITOR, CER, TDK	15 μ , 25V
C	3	C1206C104K5RAC	CAPACITOR, CER, KEMET	0.1 μ , 50V
C	4	C1206C103K5RAC	CAPACITOR, CER, KEMET	0.01 μ , 50V
C	5	C3216X7R2A104KT	CAPACITOR, CER, TDK	0.1 μ , 100V
D	1	MURA110T3	DIODE, 100V, ON SEMI	
L	1	SLF7045T-101MR60-1	BUCK INDUCTOR, TDK	100 μ H
R	1	CRCW12062003F	RESISTOR	200K
R	2	CRCW12061003F	RESISTOR	100K
R	3	CRCW12063011F	RESISTOR	3.01K
R	4	CRCW12061001F	RESISTOR	1K
R	5	CRCW12061R00F	RESISTOR	1
U	1	LM5007	REGULATOR, TEXAS INSTRUMENTS	

7 Efficiency Measurements

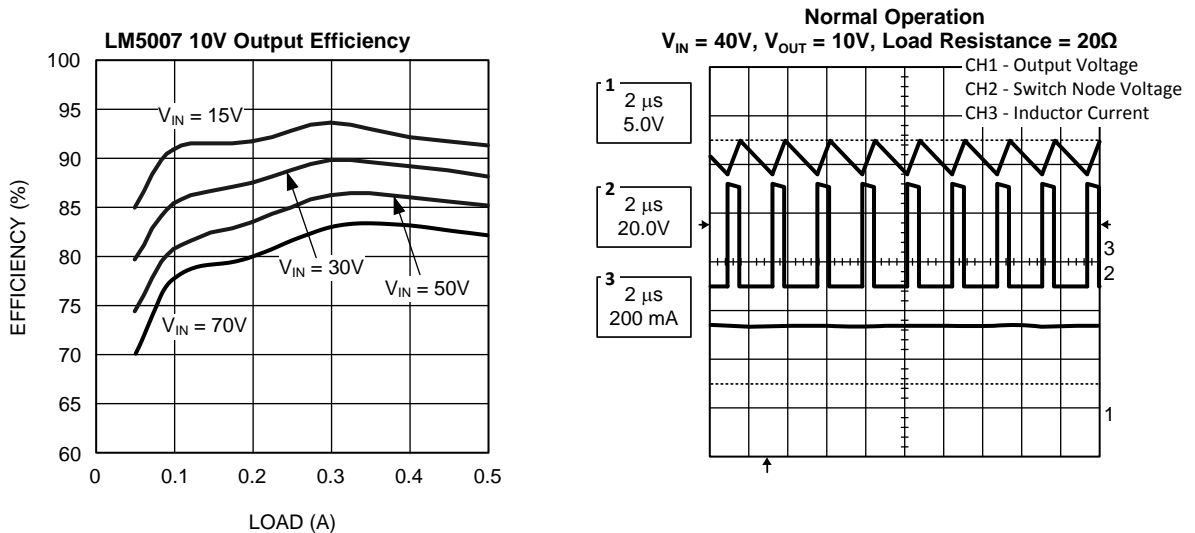

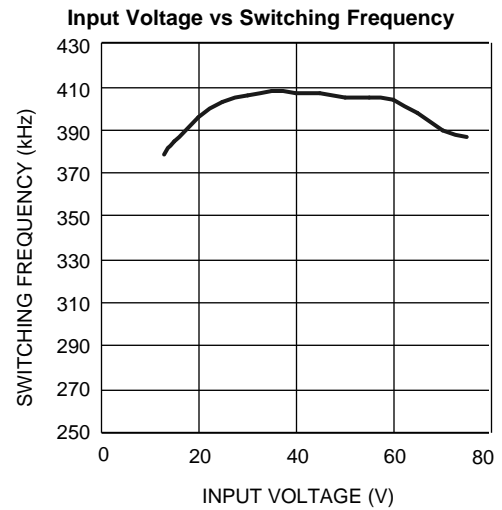
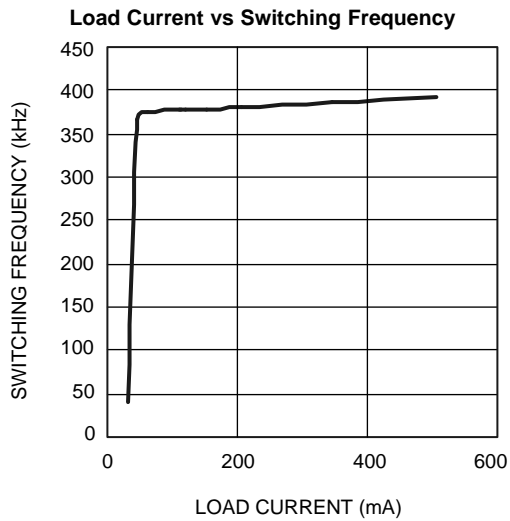
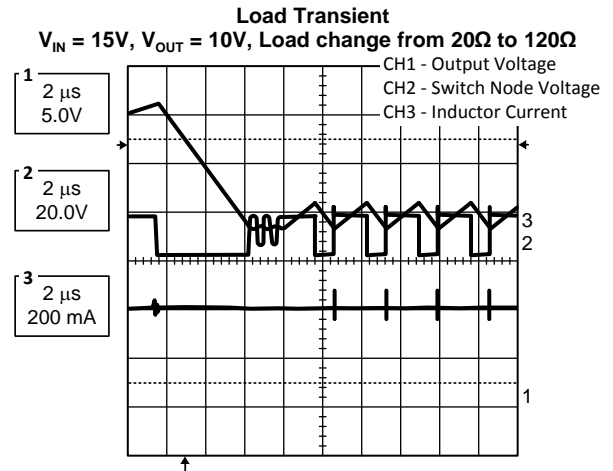
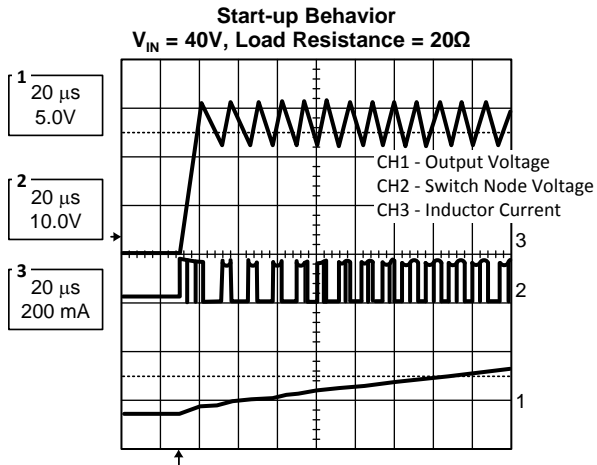

8 PCB Layouts

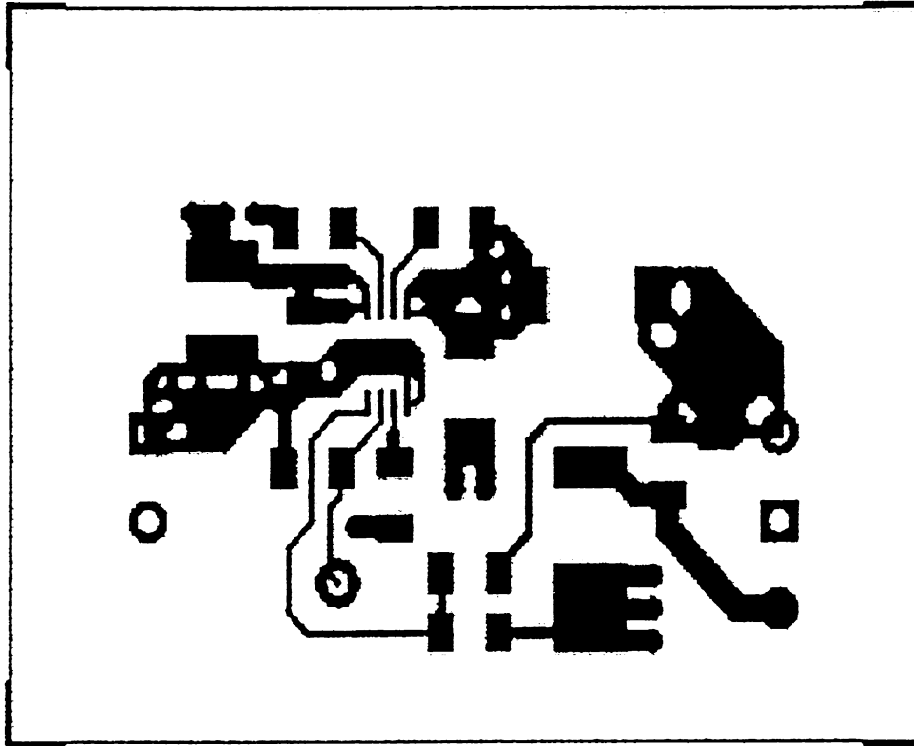

Figure 3. Top Layer

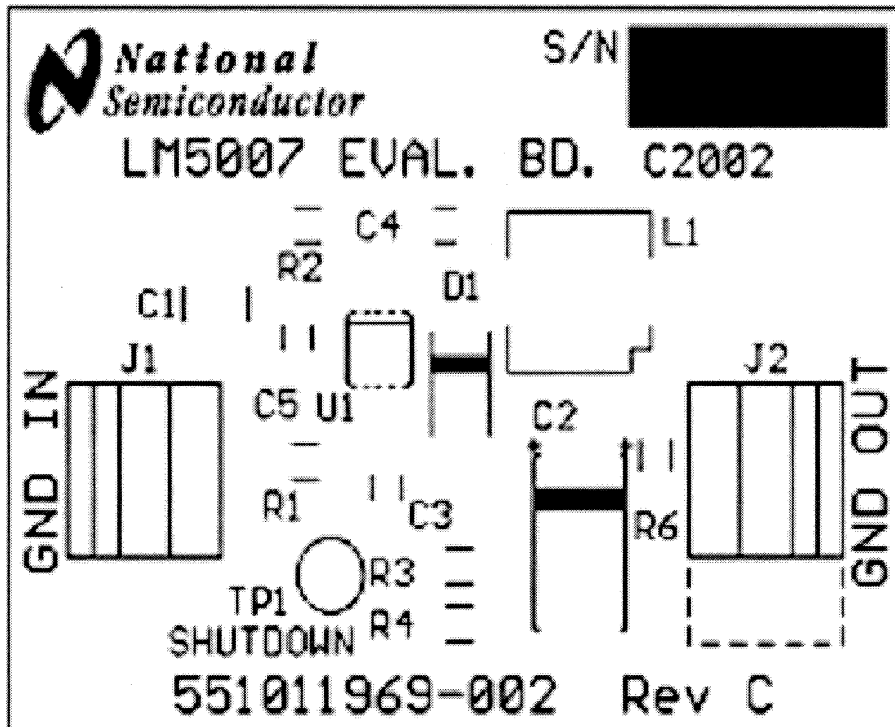

Figure 4. Silk Screen

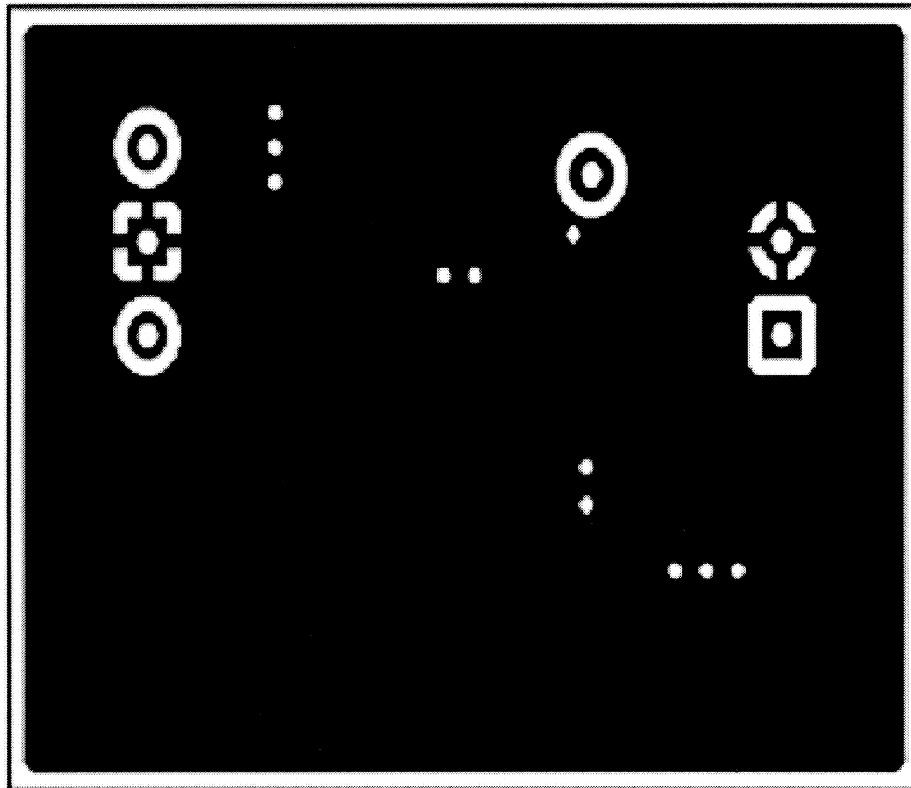

Figure 5. Bottom Layer

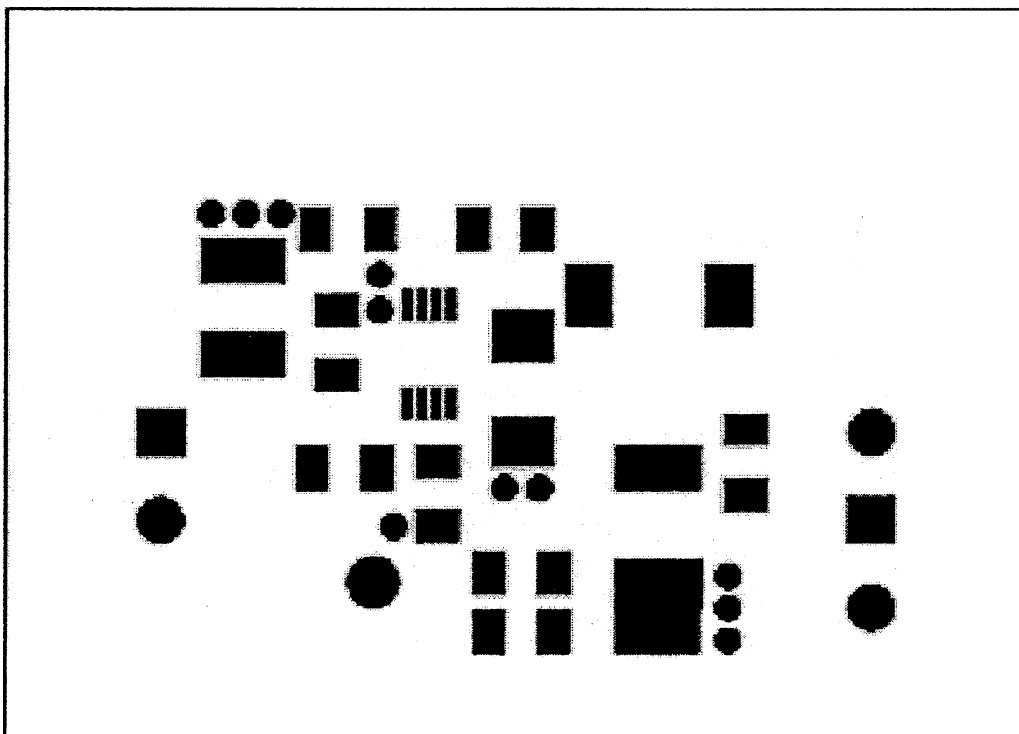

Figure 6. Top Soldermask

IMPORTANT NOTICE

Texas Instruments Incorporated and its subsidiaries (TI) reserve the right to make corrections, enhancements, improvements and other changes to its semiconductor products and services per JESD46, latest issue, and to discontinue any product or service per JESD48, latest issue. Buyers should obtain the latest relevant information before placing orders and should verify that such information is current and complete. All semiconductor products (also referred to herein as "components") are sold subject to TI's terms and conditions of sale supplied at the time of order acknowledgment.

TI warrants performance of its components to the specifications applicable at the time of sale, in accordance with the warranty in TI's terms and conditions of sale of semiconductor products. Testing and other quality control techniques are used to the extent TI deems necessary to support this warranty. Except where mandated by applicable law, testing of all parameters of each component is not necessarily performed.

TI assumes no liability for applications assistance or the design of Buyers' products. Buyers are responsible for their products and applications using TI components. To minimize the risks associated with Buyers' products and applications, Buyers should provide adequate design and operating safeguards.

TI does not warrant or represent that any license, either express or implied, is granted under any patent right, copyright, mask work right, or other intellectual property right relating to any combination, machine, or process in which TI components or services are used. Information published by TI regarding third-party products or services does not constitute a license to use such products or services or a warranty or endorsement thereof. Use of such information may require a license from a third party under the patents or other intellectual property of the third party, or a license from TI under the patents or other intellectual property of TI.

Reproduction of significant portions of TI information in TI data books or data sheets is permissible only if reproduction is without alteration and is accompanied by all associated warranties, conditions, limitations, and notices. TI is not responsible or liable for such altered documentation. Information of third parties may be subject to additional restrictions.

Resale of TI components or services with statements different from or beyond the parameters stated by TI for that component or service voids all express and any implied warranties for the associated TI component or service and is an unfair and deceptive business practice. TI is not responsible or liable for any such statements.

Buyer acknowledges and agrees that it is solely responsible for compliance with all legal, regulatory and safety-related requirements concerning its products, and any use of TI components in its applications, notwithstanding any applications-related information or support that may be provided by TI. Buyer represents and agrees that it has all the necessary expertise to create and implement safeguards which anticipate dangerous consequences of failures, monitor failures and their consequences, lessen the likelihood of failures that might cause harm and take appropriate remedial actions. Buyer will fully indemnify TI and its representatives against any damages arising out of the use of any TI components in safety-critical applications.

In some cases, TI components may be promoted specifically to facilitate safety-related applications. With such components, TI's goal is to help enable customers to design and create their own end-product solutions that meet applicable functional safety standards and requirements. Nonetheless, such components are subject to these terms.

No TI components are authorized for use in FDA Class III (or similar life-critical medical equipment) unless authorized officers of the parties have executed a special agreement specifically governing such use.

Only those TI components which TI has specifically designated as military grade or "enhanced plastic" are designed and intended for use in military/aerospace applications or environments. Buyer acknowledges and agrees that any military or aerospace use of TI components which have **not** been so designated is solely at the Buyer's risk, and that Buyer is solely responsible for compliance with all legal and regulatory requirements in connection with such use.

TI has specifically designated certain components as meeting ISO/TS16949 requirements, mainly for automotive use. In any case of use of non-designated products, TI will not be responsible for any failure to meet ISO/TS16949.

Products

Audio	www.ti.com/audio
Amplifiers	amplifier.ti.com
Data Converters	dataconverter.ti.com
DLP® Products	www.dlp.com
DSP	dsp.ti.com
Clocks and Timers	www.ti.com/clocks
Interface	interface.ti.com
Logic	logic.ti.com
Power Mgmt	power.ti.com
Microcontrollers	microcontroller.ti.com
RFID	www.ti-rfid.com
OMAP Applications Processors	www.ti.com/omap
Wireless Connectivity	www.ti.com/wirelessconnectivity

Applications

Automotive and Transportation	www.ti.com/automotive
Communications and Telecom	www.ti.com/communications
Computers and Peripherals	www.ti.com/computers
Consumer Electronics	www.ti.com/consumer-apps
Energy and Lighting	www.ti.com/energy
Industrial	www.ti.com/industrial
Medical	www.ti.com/medical
Security	www.ti.com/security
Space, Avionics and Defense	www.ti.com/space-avionics-defense
Video and Imaging	www.ti.com/video

TI E2E Community

e2e.ti.com

Looking for pricing, stock, or lifecycle information?

Click below to explore more details on WIN SOURCE:

 [View LMV358QPW](#) on WIN SOURCE

 [Texas Instruments](#) Information

Optimize Your Supply Chain with WIN SOURCE Solutions

-  Global Sourcing Solution
-  Obsolete Management
-  Cost Control Management
-  Shortage Management
-  Alternative Solution
-  Excess Inventory Management