

Power Supply IC Series for TFT-LCD Panels

5V Input Multi-channel System Power Supply IC

BD8179MUV

No.09035EBT04

●Description

The BD8179MUV is a system power supply IC for TFT panels.

A 1-chip IC providing a total of three voltages required for TFT panels, i.e., source voltage, gate high-level, and gate low-level voltage, thus constructing a TFT panel power supply with minimal components required.

●Features

- 1) Step Up DC/DC Converter.
- 2) Incorporates 18V, 3.0A N-channel FET
- 3) Linear-Regulator Controllers for VGON and VGOFF
- 4) 5 channel Operational Amplifiers/ $\pm 150\text{mA}$ Output Short-Circuit Current 40V / μs Slew Rate
- 5) Switching Frequency: 1200 kHz.
- 6) Gate Shading Function Included.
- 7) Protection Circuits
- 8) Over Current Protection
- 9) Timer Latch Mode Short Current Protection.
- 10) Thermal Shut Down.
- 11) Under Voltage Protection.
- 12) Over Voltage Protection
- 13) VQFN032V5050 Package

●Applications

Liquid crystal TV, PC monitor, and TFT-LCD panel

●Absolute maximum ratings (Ta = 25°C)

Parameter	Symbol	Limit	Unit
Power Supply Voltage	VIN	7	V
VMAIN Voltage	VMAIN	20	V
SUP Voltage	VSUP	20	V
DRVP Voltage	VDRVP	40	V
DRVN Voltage	VDRVN	-30	V
SRC Voltage	VSRC	40	V
CTL Voltage	VCTL	7	V
Junction Temperature	Tjmax	150	°C
Power Dissipation	Pd	4560	mW
Operating Temperature Range	Topr	-40~85	°C
Storage Temperature Range	Tstg	-55~150	°C

* Reduced by 19.52 mW/°C over 25°C, when mounted on a glass epoxy board.
 (4-layer 74.2 mm × 74.2 mm × 1.6 mm).

●Operating Condition

Parameter	Symbol	Limit		Unit
		Min.	Max.	
Power Supply Voltage	VIN	2.6	5.5	V
VMAIN Voltage	VMAIN	8	18	V
SUP Voltage	VSUP	-	18	V
DRVP Voltage	VDRVP	-	38	V
DRVN Voltage	VDRVN	-	-20	V
SRC Voltage	VSRC	-	38	V

● **Electrical Characteristics** (Unless otherwise specified, $V_{IN} = 3.3V$; $V_{SUP} = 12V$; $V_{GON} = 25V$; $V_{GOFF} = -6V$; $T_a = 25^\circ C$)

1 DC/DC CONVERTER CONTROLLER BLOCK

Parameter	Symbol	Limit			Unit	Conditions
		Min.	Typ.	Max.		
[ERROR AMPLIFIER BLOCK]						
FB Input Bias Current	IFB	-	0.1	-	μA	
Feed Back Voltage	VFB	1.221	1.233	1.245	V	Buffer, No load
Comp Sink Current	loi	1	5	10	μA	VFB=1.5V VCOMP=0.5V
Comp Source Current	loo	-10	-5	-1	μA	VFB=1.0V VCOMP=0.5V
[LX BLOCK]						
LX ON-Resistance	Ron	-	200	-	m Ω	
LX Leak Current	lieak	-	0	10	μA	VLX=18V
MAX Duty Cycle	DMAX	-	90	-	%	
LX Current Limit	ILX	2.5	-	-	A	
[INTERNAL SOFT START BLOCK]						
Soft Start Delay Time	tss	-	3.25	-	ms	

2. GATE-ON LINEAR REGULATOR CONTROLLER

Parameter	Symbol	Limit			Unit	Conditions
		Min.	Typ.	Max.		
FBP Voltage	VFBP	1.225	1.25	1.275	V	
FBP Input Bias Current	IFBP	-	0.1	-	μA	
DRVP Current Limit	IDRVP	1	5	10	mA	

3. GATE-OFF LINEAR REGULATOR CONTROLLER

Parameter	Symbol	Limit			Unit	Conditions
		Min.	Typ.	Max.		
FBN Voltage	VFBN	0.235	0.25	0.265	V	
FBN Input Bias Current	IFBN	-	0.1	-	μA	
DRVN Current Limit	IDRVN	1	5	10	mA	

4. OPERATIONAL AMPLIFIERS

Parameter	Symbol	Limit			Unit	Conditions
		Min.	Typ.	Max.		
Input Offset Voltage	Voff	-	0	-	mV	VPOS1 ~ 5 = 6V
Input Range	VRANGE	0		V _{SUP}	V	
DRIVE Current	Idrv	50	-	-	mA	
Slew Rate	SR	-	40	-	V/us	

5. GATE SHADING CONTROLLER BLOCK

Parameter	Symbol	Limit			Unit	Conditions
		Min.	Typ.	Max.		
DEL Start Period	tdd	-	15	-	ms	
DEL Source Current	Idls	-8	-5	-2	μA	
DEL Threshold Voltage	Vdls	1.2	1.25	1.3	V	
CTL Input Low Voltage	VctlL	-	-	$V_{IN} \times 0.3$	V	
CTL Input High Voltage	VctlH	$V_{IN} \times 0.7$	-	-	V	
CTL Input Current	Ictl	8	16.5	25	μA	V _{CTL} =3.3V
SRC ON Resistance	RonsRC	-	5	-	Ω	
DRN ON Resistance	RonDRV	-	30	-	Ω	

○ This product is not designed for protection against radioactive rays.

● **Electrical Characteristics** (Unless otherwise specified, $V_{IN} = 3.3V$; $V_{SUP} = 12V$; $V_{GON} = 25V$; $V_{GOFF} = -6V$; $T_a = 25^\circ C$)

6. WHOLE DEVICE

Parameter	Symbol	Limit			Unit	Conditions
		Min.	Typ.	Max.		
[REFERENCE BLOCK]						
Reference Voltage	VREF	1.231	1.25	1.269	V	
[OSCILLATION BLOCK]						
Oscillation Frequency	Fosc	1020	1200	1380	kHz	
[VIN UNDER VOLTAGE LOCK OUT BLOCK]						
Detect Voltage	Vuvlo	2.25	2.4	2.55	V	
[SUP OVER VOLTAGE LOCK OUT BLOCK]						
Detect Voltage	Vovp	18	19	20	V	
[SHORT CURRENT PROTECTION BLOCK]						
Fault Delay Time	Tscp	-	150	-	ms	
[DETECTOR BLOCK]						
VFB OFF Threshold Voltage	Vthfb	0.9	1.0	1.1	V	
VFBP OFF Threshold Voltage	Vthfbp	0.9	1.0	1.1	V	
VFBN OFF Threshold Voltage	Vthfpn	0.4	0.5	0.6	V	

○ This product is not designed for protection against radio active rays.

●Reference Data (Unless otherwise specified, Ta = 25°C, VIN=5V)

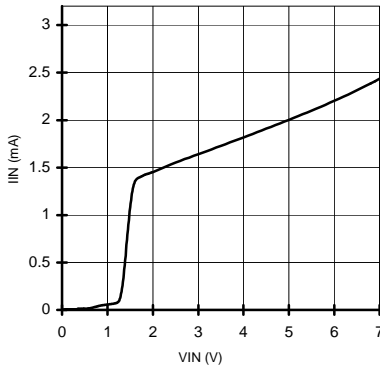

Fig.1 Supply Current (No switching)

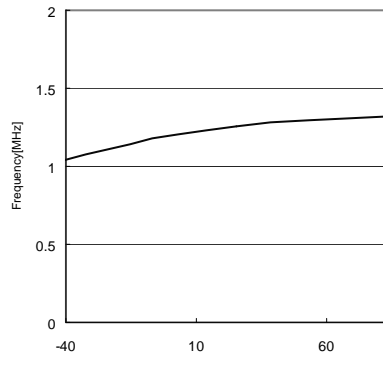

Fig.2 Switching Frequency vs Temperature

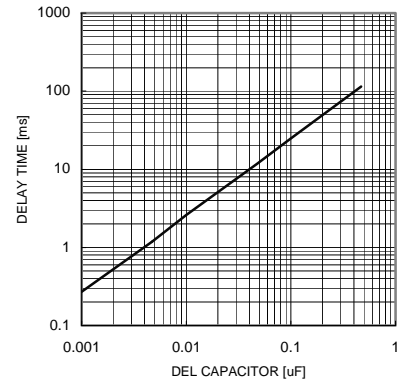

Fig.3 Delay Time vs Capacitor

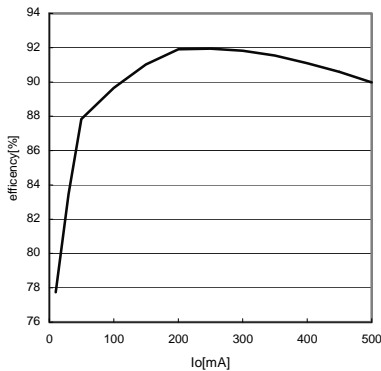

Fig.4 Efficiency vs Output Current (VMAIN)

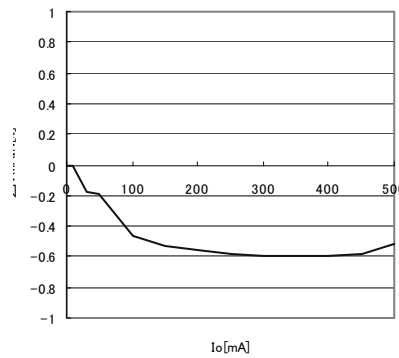

Fig.5 VMAIN Voltage Load Regulation

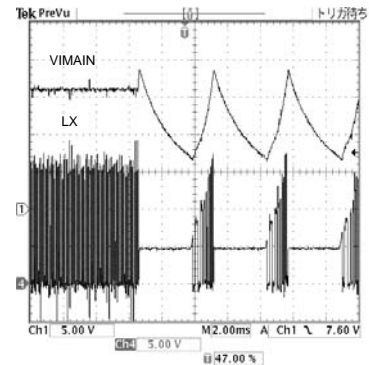

Fig.6 Over Voltage Protect waveform

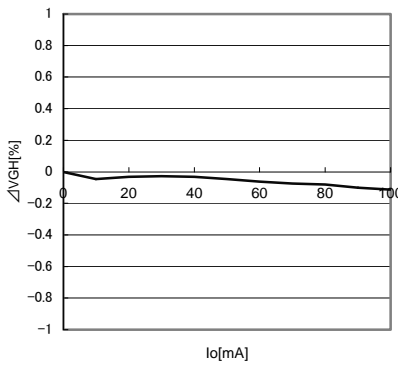

Fig.7 Gate-ON Voltage Load Regulation

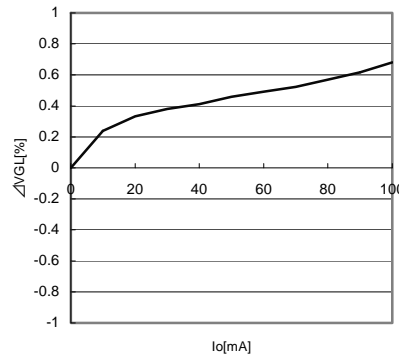

Fig.8 Gate-OFF Voltage Load Regulation

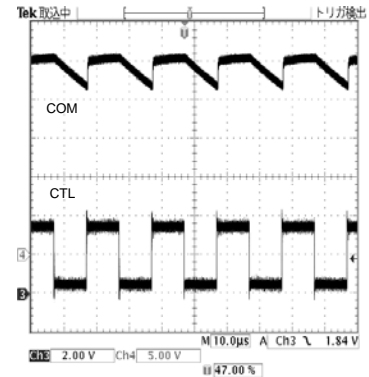

Fig.9 Gate Shading Output waveform

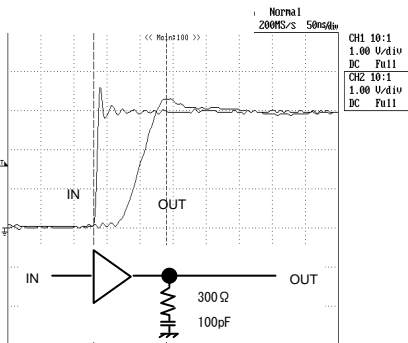

Fig.10 AMP Slew Rate (Rise)

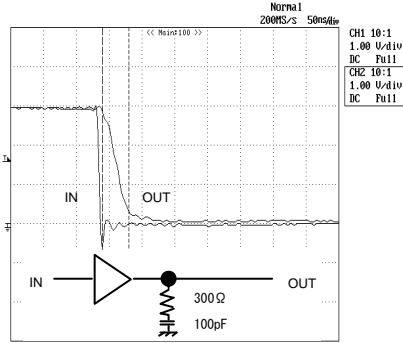

Fig.11 AMP Slew Rate (Fall)

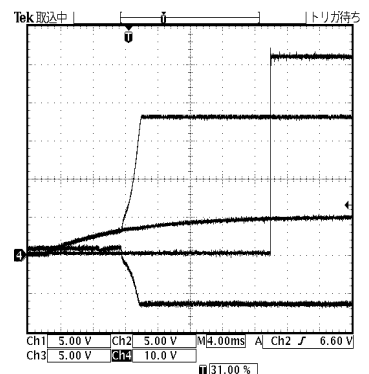
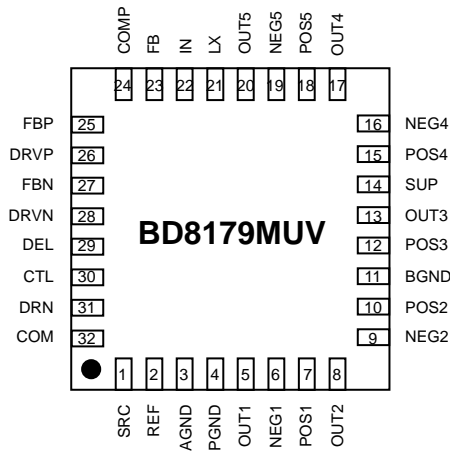
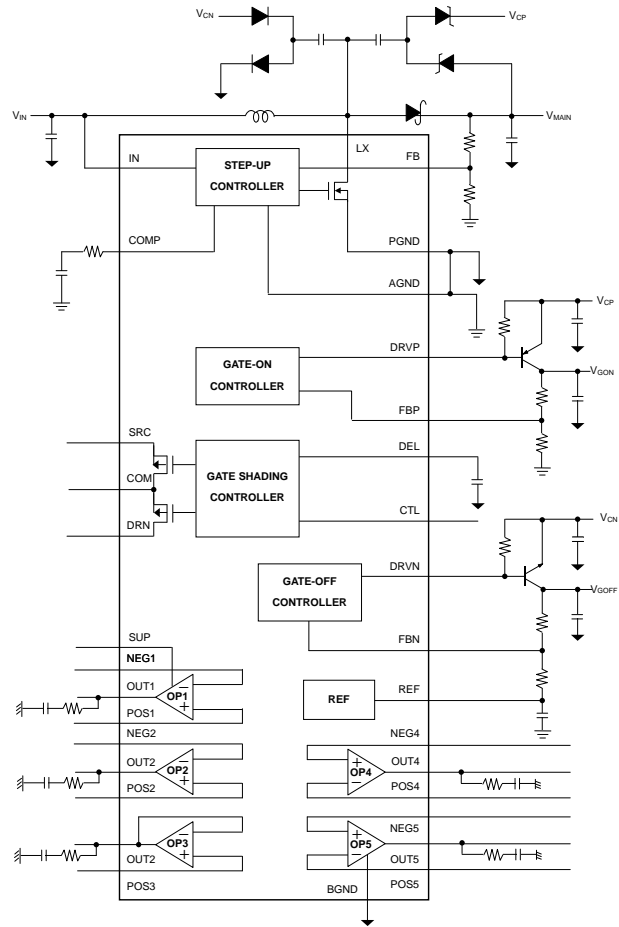

Fig.12 Start Up Sequence waveform

● Pin Assignments Diagram



● Block Diagram



● Pin Assignments

PIN NO.	Pin Name	Function	PIN NO.	Pin Name	Function
1	SRC	Highside Input for Gate Shading switch	17	OUT4	Operational Amplifier 4 Output
2	REF	Reference for VG OFF	18	POS5	Operational Amplifier 5 Noninverting Input
3	AGND	Ground	19	NEG5	Operational Amplifier 5 Inverting Input
4	PGND	Power Ground	20	OUT5	Operational Amplifier 5 Output
5	OUT1	Operational Amplifier 1 Output	21	LX	Nch Power MOS FET Drain and Switching Node
6	NEG1	Operational Amplifier 1 Inverting Input	22	IN	Power Supply voltage Input
7	POS1	Operational Amplifier 1 Noninverting Input	23	FB	Feedback Input for step up DC/DC
8	OUT2	Operational Amplifier 2 Output	24	COMP	Error Amplifier Compensation Point for step up DC/DC
9	NEG2	Operational Amplifier 2 Inverting Input	25	FBP	Feedback Input for Gate-ON Linear-Regulator
10	POS2	Operational Amplifier 2 Noninverting Input	26	DRVP	Gate-ON Linear-Regulator Base Drive
11	BGND	Ground	27	FBN	Feedback Input for Gate-OFF Linear-Regulator
12	POS3	Operational Amplifier 3 Noninverting Input	28	DRVN	Gate-OFF Linear-Regulator Base Drive
13	OUT3	Operational Amplifier 3 Output	29	DEL	Delay Input for Gate Shading
14	SUP	Power Supply voltage Input for operational Amplifier	30	CTL	Switch Control Input for Gate Shading
15	POS4	Operational Amplifier 4 Noninverting Input	31	DRN	Lowside Input for Gate Shading switch
16	NEG4	Operational Amplifier 4 Inverting Input	32	COM	Gate Shading Output

●Block Function

- Step-up Controller
A controller circuit for DC/DC boosting.
The switching duty is controlled so that the feedback voltage FB is set to 1.233 V (typ.).
A soft start operates at the time of starting.
- Gate-on Controller
A controller circuit for the positive-side charge pump.
The liner regulator controls so that the feedback voltage FBP will be set to 1.25 V (typ.).
- Gate-off Controller
A controller circuit for the negative-side charge pump.
The liner regulator controls so that the feedback voltage FBN will be set to 0.25 V (Typ.).
- Gate Shading Controller
A controller circuit for MOS FET Switch
The COM switching synchronize with CTL input.
- Start-up Controller
A control circuit for the starting sequence.
Controls to start in order of $V_{CC} \rightarrow V_{MAIN} \rightarrow V_{GOFF}/V_{GON} \rightarrow V_{COM}$
- REF
A block that generates internal reference voltage. 1.25V (Typ.) is output.
- TSD/UVLO/OVP
Thermal shutdown/Under-voltage lockout protection/circuit blocks.
The thermal shutdown circuit is shut down at an IC internal temperature of 175°C and reactivate at 160°C.
The under-voltage lockout protection circuit shuts down the IC when the V_{IN} is 2.4 V (typ.) or below.
The over-voltage lockout protection circuit shuts down the IC when the SUP is 19.0 V (typ.) or over.
- OP1~OP5
Operational amplifier block

●Starting sequence

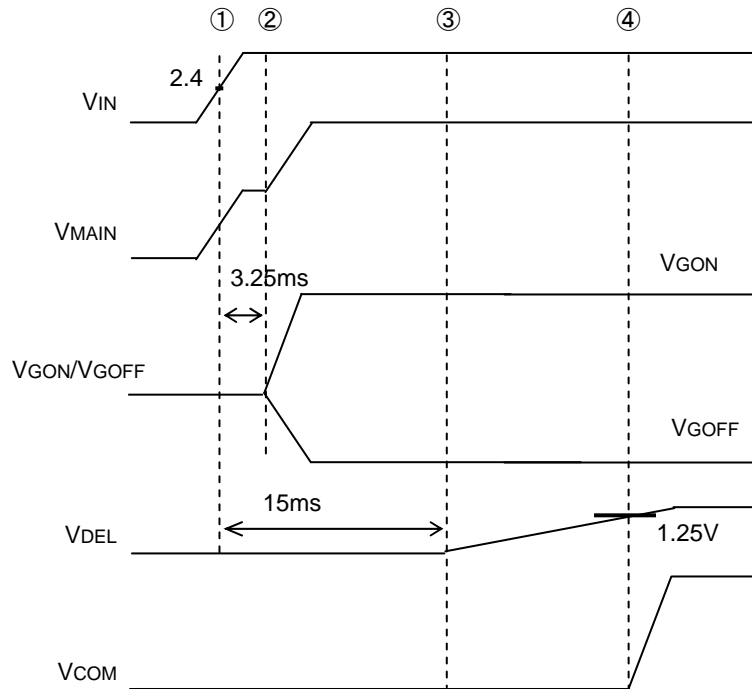

- ①UVLO released when V_{IN} voltage reaches 2.4V
- ②Step up DCDC converter starts switching, and V_{GON} and V_{GOFF} starts.
- ③ V_{DEL} starts.
- ④ V_{COM} ON when V_{DEL} reaches 1.25V

● Under Voltage Lock Out (UVLO)

The UVLO circuit compares the input voltage at IN with the UVLO threshold (2.4V rising, 2.2V falling, typ) to ensure the input voltage is high enough for reliable operation.

The 200mV (typ) hysteresis prevents supply transients from causing a restart. Once the input voltage exceeds the UVLO rising threshold, startup begins. When the input voltage falls below the UVLO falling threshold, the controller turns off the main step-up regulator, turns off the linear-regulator outputs, and disables the Gate Shading controller.

● Thermal Shut Down (TSD)

The TSD prevents excessive power dissipation from overheating the BD8179MUV. When the junction temperature exceeds $T_j=175^{\circ}\text{C}$ (Typ), a thermal sensor immediately activates. The fault protection, which shuts down all outputs except the reference, allowing the device to cool down. Once the device cools down by approximately 15°C reactivate the device.

● Over Voltage Protection (OVP)

The Step up DC/DC converter has OVP circuit.

The OVP circuit compares the input Voltage at SUP with the OVP threshold (19V rising, 18.5V falling, Typ) to protect the step up DC/DC output exceed the absolute maximum voltage. Once the SUP Voltage exceeds the OVP rising threshold, turn off the main Step-up regulator.

Then, the SUP Voltage falls below the OVP falling threshold,reactivate the main Step-Up regulator.

● Over Current Protection (OCP)

The Step-Up DC/DC converter, linear-regulator and Operational Amplifier have OCP circuit respectively.

The OCP circuit restricts to load current, when an OCP activated, one's own output only restricted.

However, if the output continue to overload, the device is possible to activate thermal shutdown or short current protection.

● Timer Latch Mode Short Current Protection (SCP)

BD8179MUV has SCP circuit feature to prevent the large current flowing when the output is shorted to GND.

This function is monitoring VMAIN, VGON, and VGOFF Voltage and starts the timer when at least one of the outputs operating properly (when the output voltage was lower than expected).

After 150ms (Typ.) of this abnormal state, the device will shutdown the all outputs and latch the state.

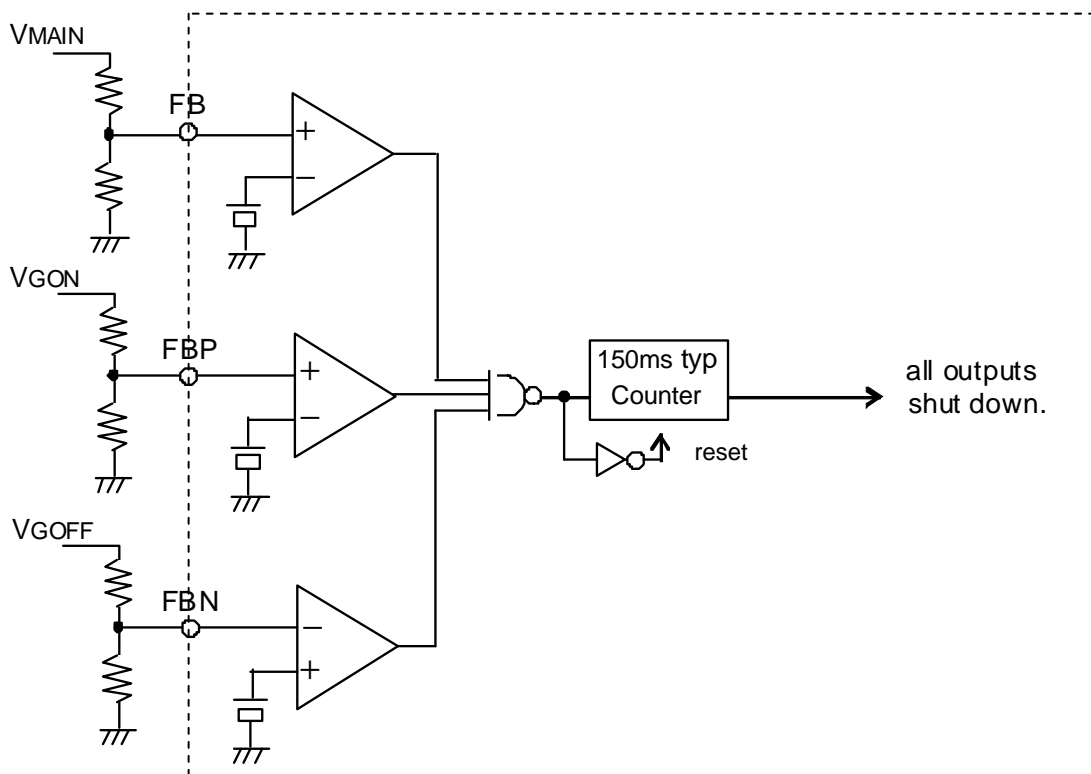

Fig.13 SCP Block Diagram

●Selecting Application Components

(1) Setting the Output L Constant

The coil to use for output is decided by the rating current I_{LR} and input current maximum value I_{INMAX} of the coil.

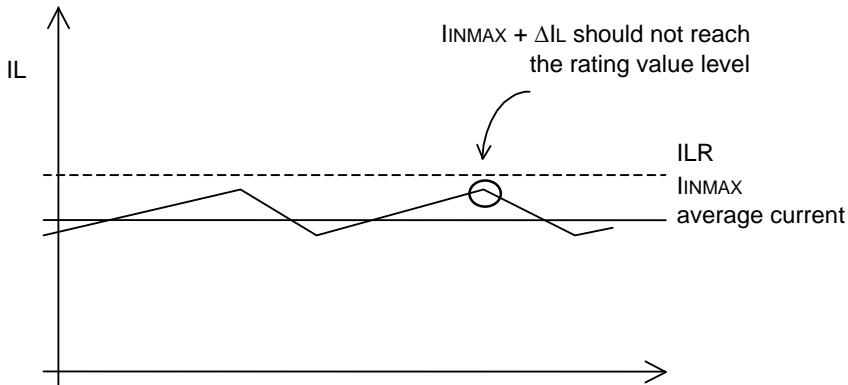

Fig. 14 Coil Current Waveform

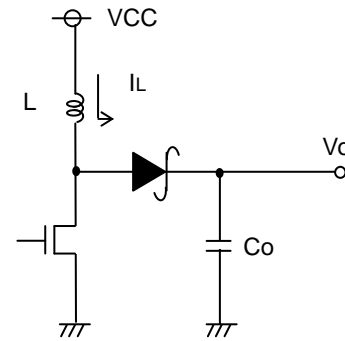

Fig. 15 Output Application Circuit Diagram

Adjust so that $I_{INMAX} + \Delta I_L$ does not reach the rating current value I_{LR} . At this time, ΔI_L can be obtained by the following equation.

$$\Delta I_L = \frac{1}{L} \times \frac{V_{CC}}{f} \times \frac{V_o - V_{CC}}{V_{CC}} \times \frac{1}{f} \text{ [A]} \quad \text{Here, } f \text{ is the switching frequency.}$$

Set with sufficient margin because the coil value may have the dispersion of $\pm 30\%$. If the coil current exceeds the rating current I_{LR} of the coil, it may damage the IC internal element.

BD8179MUV uses the current mode DC/DC converter control and has the optimized design at the coil value. A coil inductance (L) of 4.7 μH to 15 μH is recommended from viewpoints of electric power efficiency, response, and stability.

(2) Output Capacity Settings

For the capacitor to use for the output, select the capacitor which has the larger value in the ripple voltage V_{PP} allowance value and the drop voltage allowance value at the time of sudden load change. Output ripple voltage is decided by the following equation.

$$\Delta V_{PP} = I_{LMAX} \times \text{RESR} + \frac{1}{f C_o} \times \frac{V_{CC}}{V_o} \times \left(I_{LMAX} - \frac{\Delta I_L}{2} \right) \text{ [V]} \quad \text{Here, } f \text{ is the switching frequency.}$$

Perform setting so that the voltage is within the allowable ripple voltage range. For the drop voltage during sudden load change; V_{DR} , please perform the rough calculation by the following equation.

$$V_{DR} = \frac{\Delta I}{C_o} \times 10 \text{ us} \quad \text{[V]}$$

However, 10 μs is the rough calculation value of the DC/DC response speed. Please set the capacitance considering the sufficient margin so that these two values are within the standard value range.

(3) Selecting the Input Capacitor

Since the peak current flows between the input and output at the DC/DC converter, a capacitor is required to install at the input side. For the reason, the low ESR capacitor is recommended as an input capacitor which has the value more than 10 μF and less than 100 m Ω . If a capacitor out of this range is selected, the excessive ripple voltage is superposed on the input voltage, accordingly it may cause the malfunction of IC.

However these conditions may vary according to the load current, input voltage, output voltage, inductance and switching frequency. Be sure to perform the margin check using the actual product.

(4) Setting RC, Cc of the Phase Compensation Circuit

In the current mode control, since the coil current is controlled, a pole (phase lag) made by the CR filter composed of the output capacitor and load resistor will be created in the low frequency range, and a zero (phase lead) by the output capacitor and ESR of capacitor will be created in the high frequency range. In this case, to cancel the pole of the power amplifier, it is easy to compensate by adding the zero point with Cc and Rc to the output from the error amp as shown in the illustration.

Open loop gain characteristics

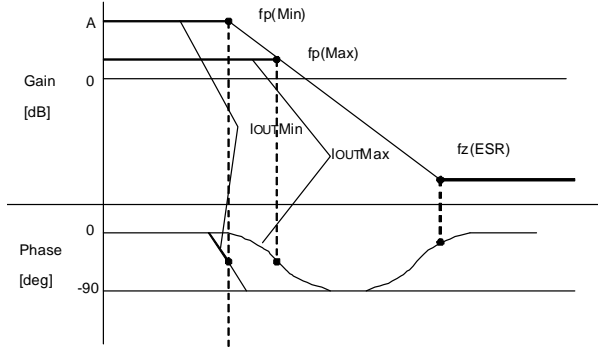

$$F_p = \frac{1}{2 \pi \times R_O \times C_O} \quad [\text{Hz}]$$

$$f_z(\text{ESR}) = \frac{1}{2 \pi \times \text{ESR} \times C_O} \quad [\text{Hz}]$$

Pole at the power amplification stage

When the output current reduces, the load resistance R_o increases and the pole frequency lowers.

$$f_p(\text{Min}) = \frac{1}{2 \pi \times R_{O\text{Max}} \times C_O} \quad [\text{Hz}] \leftarrow \text{at light load}$$

$$f_z(\text{Max}) = \frac{1}{2 \pi \times R_{O\text{Min}} \times C_O} \quad [\text{Hz}] \leftarrow \text{at heavy load}$$

Error amp phase compensation characteristics

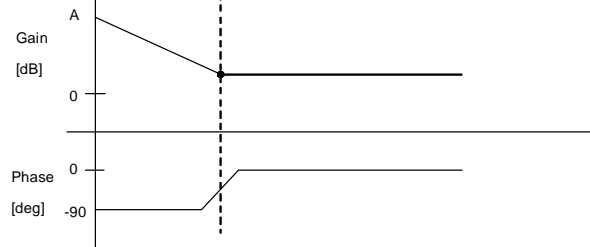

Zero at the power amplification stage

When the output capacitor is set larger, the pole frequency lowers but the zero frequency will not change. (This is because the capacitor ESR becomes 1/2 when the capacitor becomes 2 times.)

$$f_p(\text{Amp.}) = \frac{1}{2 \pi \times R_c \times C_c} \quad [\text{Hz}]$$

Fig. 16 Gain vs Phase

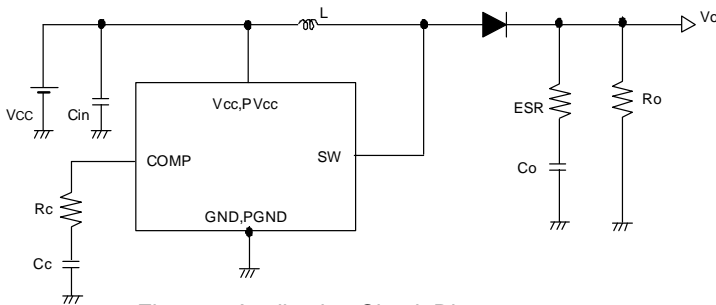

Fig. 17 Application Circuit Diagram

It is possible to realize the stable feedback loop by canceling the pole $f_p(\text{Min.})$, which is created by the output capacitor and load resistor, with CR zero compensation of the error amp as shown below.

$$f_z(\text{Amp.}) = f_p(\text{Min.})$$

$$\longrightarrow \frac{1}{2 \pi \times R_c \times C_c} = \frac{1}{2 \pi \times R_{o\text{max}} \times C} \quad [\text{Hz}]$$

(5) Design of the Feedback Resistor Constant

Refer to the following equation to set the feedback resistor. As the setting range, 10 kΩ to 330 kΩ is recommended. If the resistor is set lower than a 10 kΩ, it causes the reduction of power efficiency. If it is set more than 330 kΩ, the offset voltage becomes larger by the input bias current 0.4 μA(Typ.) in the internal error amplifier.

$$V_{MAIN} = \frac{R1 + R2}{R2} \times 1.233 \quad [V]$$

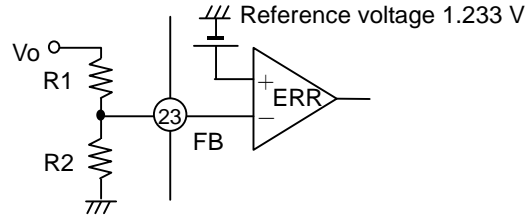

(6) Positive-side Charge Pump Settings

BD8179MUV incorporates a charge pump controller, thus making it possible to generate stable gate voltage.

The output voltage is determined by the following formula. As the setting range, 10 kΩ to 330 kΩ is recommended. If the resistor is set lower than a 10kΩ, it causes the reduction of power efficiency. If it is set more than 330 kΩ, the offset voltage becomes larger by the input bias current 0.4 μA (Typ.) in the internal error amp.

$$V_{GON} = \frac{R3 + R4}{R4} \times 1.25 \quad [V]$$

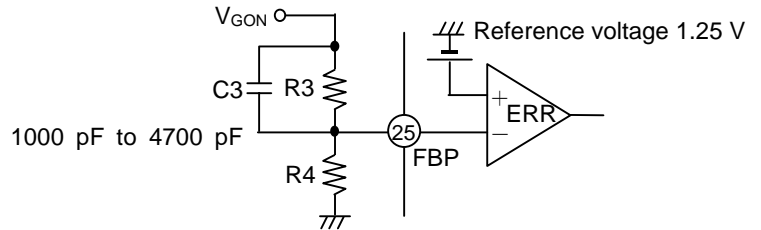

In order to prevent output voltage overshooting, add capacitor C3 in parallel with R3. The recommended capacitance is 1000 pF to 4700 pF. If a capacitor outside this range is inserted, the output voltage may oscillate.

By connecting capacitance to the DEL, a rising delay time can be set for the positive-side charge pump.

The delay time is determined by the following formula.

- Delay time of charge pump block t_{DELAY}

$$t_{DELAY} = (C_{DEL} \times 1.25) / 5 \mu A [s]$$

Where, C_{DEL} is the external capacitance.

(7) Negative-side Charge Pump Settings

BD8179MUV incorporates a charge pump controller for negative voltage, thus making it possible to generate stable gate voltage.

The output voltage is determined by the following formula. As the setting range, 10 kΩ to 330 kΩ is recommended. If the resistor is set lower than a 10 kΩ, it causes the reduction of power efficiency. If it is set more than 330 kΩ, the offset voltage becomes larger by the input bias current 0.4 μA (Typ.) in the internal error amp.

$$V_{GOFF} = - \frac{R5}{R6} \times 1.0 + 0.25 \quad [V]$$

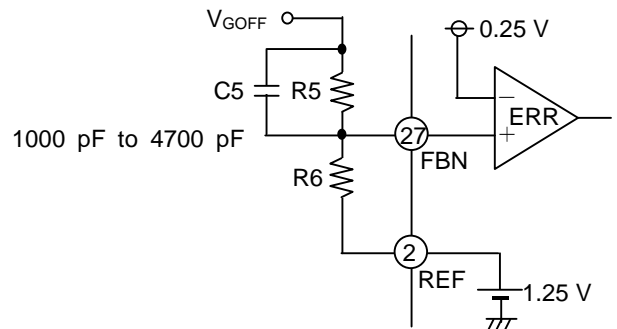

The delay time is internally fixed at 200 us.

In order to prevent output voltage overshooting, insert capacitor C5 in parallel with R5. The recommended capacitance is 1000 pF to 4700 pF. If a capacitor outside this range is inserted, the output voltage may oscillate.

●Notes for use

1) Absolute maximum ratings

Use of the IC in excess of absolute maximum ratings such as the applied voltage or operating temperature range may result in IC damage. Assumptions should not be made regarding the state of the IC (short mode or open mode) when such damage is suffered. A physical safety measure such as a fuse should be implemented when use of the IC in a special mode where the absolute maximum ratings may be exceeded is anticipated.

2) GND potential

Ensure a minimum GND pin potential in all operating conditions.

3) Setting of heat

Use a thermal design that allows for a sufficient margin in light of the power dissipation (P_d) in actual operating conditions.

4) Pin short and mistake fitting

Use caution when orienting and positioning the IC for mounting on printed circuit boards. Improper mounting may result in damage to the IC. Shorts between output pins or between output pins and the power supply and GND pins caused by the presence of a foreign object may result in damage to the IC.

5) Actions in strong magnetic field

Use caution when using the IC in the presence of a strong magnetic field as doing so may cause the IC to malfunction.

6) Testing on application boards

When testing the IC on an application board, connecting a capacitor to a pin with low impedance subjects the IC to stress. Always discharge capacitors after each process or step. Ground the IC during assembly steps as an antistatic measure, and use similar caution when transporting or storing the IC. Always turn the IC's power supply off before connecting it to or removing it from a jig or fixture during the inspection process.

7) Ground wiring patterns

When using both small signal and large current GND patterns, it is recommended to isolate the two ground patterns, placing a single ground point at the application's reference point so that the pattern wiring resistance and voltage variations caused by large currents do not cause variations in the small signal ground voltage. Be careful not to change the GND wiring patterns of any external components.

8) This monolithic IC contains P+ isolation and P substrate layers between adjacent elements in order to keep them isolated. P/N junctions are formed at the intersection of these P layers with the N layers of other elements to create a variety of parasitic elements. For example, when the resistors and transistors are connected to the pins as shown in Fig. 18, a parasitic diode or a transistor operates by inverting the pin voltage and GND voltage.

The formation of parasitic elements as a result of the relationships of the potentials of different pins is an inevitable result of the IC's architecture. The operation of parasitic elements can cause interference with circuit operation as well as IC malfunction and damage. For these reasons, it is necessary to use caution so that the IC is not used in a way that will trigger the operation of parasitic elements, such as the application of voltages lower than the GND (P board) voltage to input and output pins.

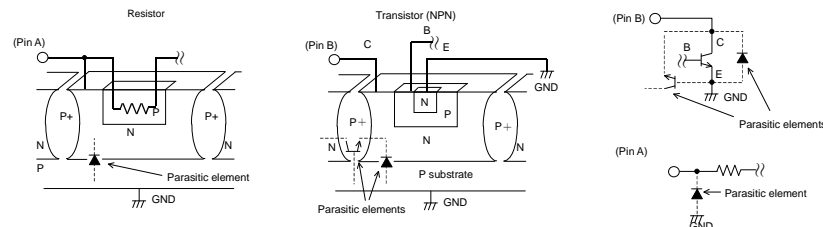

Fig.18 Example of a Simple Monolithic IC Architecture

9) Overcurrent protection circuits

An overcurrent protection circuit designed according to the output current is incorporated for the prevention of IC destruction that may result in the event of load shorting. This protection circuit is effective in preventing damage due to sudden and unexpected accidents. However, the IC should not be used in applications characterized by the continuous operation or transitioning of the protection circuits. At the time of thermal designing, keep in mind that the current capability has negative characteristics to temperatures.

10) Thermal shutdown circuit

This IC incorporates a built-in thermal shutdown circuit for the protection from thermal destruction. The IC should be used within the specified power dissipation range. However, in the event that the IC continues to be operated in excess of its power dissipation limits, the attendant rise in the chip's temperature T_j will trigger the thermal shutdown circuit to turn off all output power elements. The circuit automatically resets once the chip's temperature T_j drops.

Operation of the thermal shutdown circuit presumes that the IC's absolute maximum ratings have been exceeded. Application designs should never make use of the thermal shutdown circuit.

11) Testing on application boards

At the time of inspection of the installation boards, when the capacitor is connected to the pin with low impedance, be sure to discharge electricity per process because it may load stresses to the IC. Always turn the IC's power supply off before connecting it to or removing it from a jig or fixture during the inspection process. Ground the IC during assembly steps as an antistatic measure, and use similar caution when transporting or storing the IC.

Notice

Precaution on using ROHM Products

- Our Products are designed and manufactured for application in ordinary electronic equipments (such as AV equipment, OA equipment, telecommunication equipment, home electronic appliances, amusement equipment, etc.). If you intend to use our Products in devices requiring extremely high reliability (such as medical equipment ^(Note 1), transport equipment, traffic equipment, aircraft/spacecraft, nuclear power controllers, fuel controllers, car equipment including car accessories, safety devices, etc.) and whose malfunction or failure may cause loss of human life, bodily injury or serious damage to property ("Specific Applications"), please consult with the ROHM sales representative in advance. Unless otherwise agreed in writing by ROHM in advance, ROHM shall not be in any way responsible or liable for any damages, expenses or losses incurred by you or third parties arising from the use of any ROHM's Products for Specific Applications.

(Note1) Medical Equipment Classification of the Specific Applications

JAPAN	USA	EU	CHINA
CLASS III	CLASS III	CLASS II b	CLASS III
CLASS IV		CLASS III	

- ROHM designs and manufactures its Products subject to strict quality control system. However, semiconductor products can fail or malfunction at a certain rate. Please be sure to implement, at your own responsibilities, adequate safety measures including but not limited to fail-safe design against the physical injury, damage to any property, which a failure or malfunction of our Products may cause. The following are examples of safety measures:
 - Installation of protection circuits or other protective devices to improve system safety
 - Installation of redundant circuits to reduce the impact of single or multiple circuit failure
- Our Products are designed and manufactured for use under standard conditions and not under any special or extraordinary environments or conditions, as exemplified below. Accordingly, ROHM shall not be in any way responsible or liable for any damages, expenses or losses arising from the use of any ROHM's Products under any special or extraordinary environments or conditions. If you intend to use our Products under any special or extraordinary environments or conditions (as exemplified below), your independent verification and confirmation of product performance, reliability, etc. prior to use, must be necessary:
 - Use of our Products in any types of liquid, including water, oils, chemicals, and organic solvents
 - Use of our Products outdoors or in places where the Products are exposed to direct sunlight or dust
 - Use of our Products in places where the Products are exposed to sea wind or corrosive gases, including Cl₂, H₂S, NH₃, SO₂, and NO₂
 - Use of our Products in places where the Products are exposed to static electricity or electromagnetic waves
 - Use of our Products in proximity to heat-producing components, plastic cords, or other flammable items
 - Sealing or coating our Products with resin or other coating materials
 - Use of our Products without cleaning residue of flux (even if you use no-clean type fluxes, cleaning residue of flux is recommended); or Washing our Products by using water or water-soluble cleaning agents for cleaning residue after soldering
 - Use of the Products in places subject to dew condensation
- The Products are not subject to radiation-proof design.
- Please verify and confirm characteristics of the final or mounted products in using the Products.
- In particular, if a transient load (a large amount of load applied in a short period of time, such as pulse. is applied, confirmation of performance characteristics after on-board mounting is strongly recommended. Avoid applying power exceeding normal rated power; exceeding the power rating under steady-state loading condition may negatively affect product performance and reliability.
- De-rate Power Dissipation (Pd) depending on Ambient temperature (Ta). When used in sealed area, confirm the actual ambient temperature.
- Confirm that operation temperature is within the specified range described in the product specification.
- ROHM shall not be in any way responsible or liable for failure induced under deviant condition from what is defined in this document.

Precaution for Mounting / Circuit board design

- When a highly active halogenous (chlorine, bromine, etc.) flux is used, the residue of flux may negatively affect product performance and reliability.
- In principle, the reflow soldering method must be used; if flow soldering method is preferred, please consult with the ROHM representative in advance.

For details, please refer to ROHM Mounting specification

Precautions Regarding Application Examples and External Circuits

1. If change is made to the constant of an external circuit, please allow a sufficient margin considering variations of the characteristics of the Products and external components, including transient characteristics, as well as static characteristics.
2. You agree that application notes, reference designs, and associated data and information contained in this document are presented only as guidance for Products use. Therefore, in case you use such information, you are solely responsible for it and you must exercise your own independent verification and judgment in the use of such information contained in this document. ROHM shall not be in any way responsible or liable for any damages, expenses or losses incurred by you or third parties arising from the use of such information.

Precaution for Electrostatic

This Product is electrostatic sensitive product, which may be damaged due to electrostatic discharge. Please take proper caution in your manufacturing process and storage so that voltage exceeding the Products maximum rating will not be applied to Products. Please take special care under dry condition (e.g. Grounding of human body / equipment / solder iron, isolation from charged objects, setting of ionizer, friction prevention and temperature / humidity control).

Precaution for Storage / Transportation

1. Product performance and soldered connections may deteriorate if the Products are stored in the places where:
 - [a] the Products are exposed to sea winds or corrosive gases, including Cl₂, H₂S, NH₃, SO₂, and NO₂
 - [b] the temperature or humidity exceeds those recommended by ROHM
 - [c] the Products are exposed to direct sunshine or condensation
 - [d] the Products are exposed to high Electrostatic
2. Even under ROHM recommended storage condition, solderability of products out of recommended storage time period may be degraded. It is strongly recommended to confirm solderability before using Products of which storage time is exceeding the recommended storage time period.
3. Store / transport cartons in the correct direction, which is indicated on a carton with a symbol. Otherwise bent leads may occur due to excessive stress applied when dropping of a carton.
4. Use Products within the specified time after opening a humidity barrier bag. Baking is required before using Products of which storage time is exceeding the recommended storage time period.

Precaution for Product Label

QR code printed on ROHM Products label is for ROHM's internal use only.

Precaution for Disposition

When disposing Products please dispose them properly using an authorized industry waste company.

Precaution for Foreign Exchange and Foreign Trade act

Since our Products might fall under controlled goods prescribed by the applicable foreign exchange and foreign trade act, please consult with ROHM representative in case of export.

Precaution Regarding Intellectual Property Rights

1. All information and data including but not limited to application example contained in this document is for reference only. ROHM does not warrant that foregoing information or data will not infringe any intellectual property rights or any other rights of any third party regarding such information or data. ROHM shall not be in any way responsible or liable for infringement of any intellectual property rights or other damages arising from use of such information or data.:
2. No license, expressly or implied, is granted hereby under any intellectual property rights or other rights of ROHM or any third parties with respect to the information contained in this document.

Other Precaution

1. This document may not be reprinted or reproduced, in whole or in part, without prior written consent of ROHM.
2. The Products may not be disassembled, converted, modified, reproduced or otherwise changed without prior written consent of ROHM.
3. In no event shall you use in any way whatsoever the Products and the related technical information contained in the Products or this document for any military purposes, including but not limited to, the development of mass-destruction weapons.
4. The proper names of companies or products described in this document are trademarks or registered trademarks of ROHM, its affiliated companies or third parties.

General Precaution

1. Before you use our Products, you are requested to carefully read this document and fully understand its contents. ROHM shall not be in any way responsible or liable for failure, malfunction or accident arising from the use of any ROHM's Products against warning, caution or note contained in this document.
2. All information contained in this document is current as of the issuing date and subject to change without any prior notice. Before purchasing or using ROHM's Products, please confirm the latest information with a ROHM sales representative.
3. The information contained in this document is provided on an "as is" basis and ROHM does not warrant that all information contained in this document is accurate and/or error-free. ROHM shall not be in any way responsible or liable for any damages, expenses or losses incurred by you or third parties resulting from inaccuracy or errors of or concerning such information.

Looking for pricing, stock, or lifecycle information?

Click below to explore more details on WIN SOURCE:

- [View BD8179MUV-E2 on WIN SOURCE](#)
- [Rohm Semiconductor Information](#)

Optimize Your Supply Chain with WIN SOURCE Solutions

- ✓ Global Sourcing Solution
- ✓ Obsolete Management
- ✓ Cost Control Management
- ✓ Shortage Management
- ✓ Alternative Solution
- ✓ Excess Inventory Management