



**THE DATASHEET OF  
LT1031BCH**



## FEATURES

- Pin Compatible with LH0070 and AD581\*
- Ultralow Drift—5ppm/°C Max Slope
- Trimmed Output Voltage
- Operates in Series or Shunt Mode
- Output Sinks and Sources in Series Mode
- Very Low Noise < 1ppm<sub>P-P</sub> 0.1Hz to 10Hz
- > 100dB Ripple Rejection
- Minimum Input Voltage of 11V

## APPLICATIONS

- A-to-D and D-to-A Converters
- Precision Regulators
- Digital Voltmeters
- Inertial Navigation Systems
- Precision Scales
- Portable Reference Standard

## DESCRIPTION

The LT<sup>®</sup>1031 is a precision 10V reference with ultralow drift and noise, extremely good long term stability, and almost total immunity to input voltage variations. The reference output will both source and sink up to 10mA and can be used as a shunt regulator (two terminal Zener) with the same precision characteristics as the three terminal connection. Special care has been taken to minimize thermal regulation effects and temperature induced hysteresis.

The LT1031 reference is based on a buried Zener diode structure which eliminates noise and stability problems associated with surface breakdown devices. Further, a subsurface Zener exhibits better temperature drift and time stability than even the best band-gap references.

Unique circuit design makes the LT1031 the first three terminal IC reference to offer ultralow drift without the use of high power on-chip heaters. Output voltage is pretrimmed to 0.05% accuracy.

The LT1031 can be used as a plug-in replacement for the AD581 and LH0070,\* with improved electrical and thermal performance.

LT, LTC and LT are registered trademarks of Linear Technology Corporation. All other trademarks are the property of their respective owners. \*See LH0070 Electrical Characteristics table and AD581 cross reference guide.

## TYPICAL APPLICATION

**Basic Positive and Negative Connections**

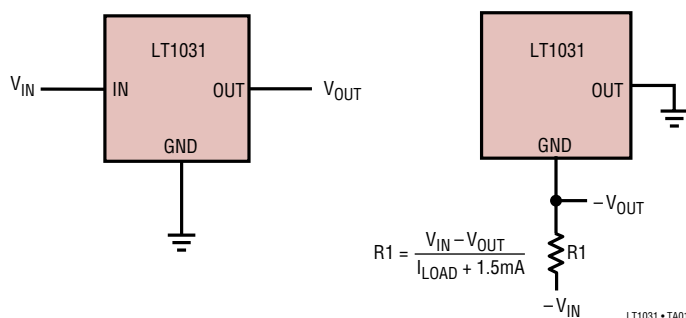

**Distribution of Output Accuracy**

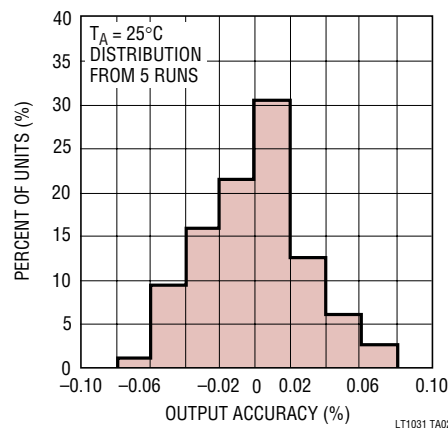

**ABSOLUTE MAXIMUM RATINGS**

(Note 1)

Input Voltage .....	40V
Input-Output Voltage Differential .....	35V
Output to Ground Voltage (Shunt Mode Current Limit) .....	16V
Trim Pin to Ground Voltage	
Positive .....	Equal to $V_{OUT}$
Negative .....	-20V
Output Short-Circuit Duration	
$V_{IN} = 35V$ .....	10 sec
$V_{IN} \leq 20V$ .....	Indefinite
Operating Temperature Range	
LT1031M .....	-55°C to 125°C
LT1031C .....	0°C to 70°C
Lead Temperature (Soldering, 10 sec) .....	300°C

**PACKAGE/ORDER INFORMATION**

BOTTOM VIEW  
INPUT

GROUND  
H PACKAGE  
3-LEAD TO-39 METAL CAN

$T_{JMAX} = 150^{\circ}C, \theta_{JA} = 150^{\circ}C/W, \theta_{JC} = 45^{\circ}C/W$  (LH0070)  
 $T_{JMAX} = 150^{\circ}C, \theta_{JA} = 150^{\circ}C/W, \theta_{JC} = 45^{\circ}C/W$  (LT1031M)  
 $T_{JMAX} = 85^{\circ}C, \theta_{JA} = 150^{\circ}C/W, \theta_{JC} = 45^{\circ}C/W$  (LT1031C)

ORDER PART NUMBER		
LH0070-0H	LT1031BMH	LT1031CCH
LH0070-1H	LT1031DMH	LT1031DCH
LH0070-2H	LT1031BCH	

**ELECTRICAL CHARACTERISTICS**

(LT1031) The ● denotes the specifications which apply over the full operating temperature range, otherwise specifications are at  $T_A = 25^{\circ}C$ .  $V_{IN} = 15V, I_{OUT} = 0$ , Mil or Comm version, unless noted.

SYMBOL	PARAMETER	CONDITIONS	LT1031			UNITS
			MIN	TYP	MAX	
$V_R$	Output Voltage (Note 2)	LT1031B	9.995	10.000	10.005	V
		LT1031C	9.990	10.000	10.010	V
		LT1031D	9.980	10.000	10.020	V
$\frac{\Delta V_R}{\Delta T}$	Output Voltage Temperature Coefficient (Note 3)	$T_{MIN} \leq T_J \leq T_{MAX}$ LT1031B ●		3	5	ppm/°C
		LT1031C ●		6	15	ppm/°C
		LT1031D ●		10	25	ppm/°C
$\frac{\Delta V_R}{\Delta V_{IN}}$	Line Regulation (Note 4)	$11.5V \leq V_{IN} \leq 14.5V$ ●		1	4	ppm/V
		$4.5V \leq V_{IN} \leq 40V$ ●		0.5	2	ppm/V
$\frac{\Delta V_R}{\Delta I_O}$	Load Regulation (Sourcing Current)	$0 \leq I_{OUT} \leq 10mA$ (Note 4) ●		12	25	ppm/mA
					40	ppm/mA
$\frac{\Delta V_R}{\Delta I_O}$	Load Regulation (Shunt Mode)	$1.7mA \leq I_{SHUNT} \leq 10mA$ (Notes 4, 5) ●		50	100	ppm/mA
					150	ppm/mA
$I_Q$	Series Mode Supply Current	●		1.2	1.7	mA
					2.0	mA
$I_{MIN}$	Shunt Mode Minimum Current	$V_{IN}$ is Open		1.1	1.5	mA
	Output Short-Circuit Current	$11V \leq V_{IN} \leq 35V$		30		mA
	Minimum Input Voltage (Note 7)	$I_{OUT} \leq 1mA$		10.8	11.0	V
$e_n$	Output Voltage Noise	$0.1Hz \leq f \leq 10Hz$		6		$\mu V_{P-P}$
		$10Hz \leq f \leq 10kHz$		11		$\mu V_{RMS}$
$\frac{\Delta V_R}{\Delta Time}$	Long Term Stability of Output Voltage	$\Delta t = 1000$ Hrs Non-Cumulative		15		ppm
	Temperature Hysteresis of Output	$\Delta T = 50^{\circ}C$		5		ppm

1031fb

**ELECTRICAL CHARACTERISTICS** (LH0070) The ● denotes the specifications which apply over the full operating temperature range.  $V_{IN} = 15V$ ,  $R_L = 10k\Omega$ ,  $-55^\circ C \leq T_A \leq 125^\circ C$ , unless noted.

SYMBOL	PARAMETER	CONDITIONS	LH0070			UNITS
			MIN	TYP	MAX	
$V_R$	Output Voltage	$T_A = 25^\circ C$		10.000		V
$\Delta V_R$	Output Accuracy -0, -1 -2	$T_A = 25^\circ C$		$\pm 0.03$	$\pm 0.1$	%
				$\pm 0.02$	$\pm 0.05$	%
$\Delta V_R$	Output Accuracy -0, -1 -2	$T_A = -55^\circ C, 125^\circ C$	●		0.3	%
					0.2	%
$\frac{\Delta V_R}{\Delta T}$	Output Voltage Change with Temperature -0 -1 -2	Note 6	●		$\pm 0.2$	%
			●	$\pm 0.02$	$\pm 0.1$	%
			●	$\pm 0.01$	$\pm 0.04$	%
$\frac{\Delta V_R}{\Delta V_{IN}}$	Line Regulation -0, -1 -2	$13V \leq V_{IN} \leq 33V, T_A = 25^\circ C$		0.006	0.1	%
				0.006	0.03	%
	Input Voltage Range		●	11.4	40	V
$\frac{\Delta V_R}{\Delta I_O}$	Load Regulation	$0mA \leq I_{OUT} \leq 5mA$	●	0.01	0.03	%
$I_Q$	Quiescent Current	$13V \leq V_{IN} \leq 33V$	●	1.2	5	mA
$\frac{\Delta I_Q}{\Delta V_{IN}}$	Change in Quiescent Current	$\Delta V_{IN} = 20V$ from 13V TO 33V	●	0.1	1.5	mA
$e_n$	Output Noise Voltage			6		$\mu V_{P-P}$
		Ripple Rejection	$f = 120Hz$	●	0.001	
$r_o$	Output Resistance		●	0.2	0.6	$\Omega$
$\frac{\Delta V_Z}{\Delta Time}$	Long Term Stability -0, -1 -2	$T_A = 25^\circ C$ (Note 8)			$\pm 0.2$	$\%/Yr$
					$\pm 0.05$	$\%/Yr$

**Note 1:** Absolute Maximum Ratings are those values beyond which the life of a device may be impaired.

**Note 2:** Output voltage is measured immediately after turn-on. Changes due to chip warm-up are typically less than 0.005%.

**Note 3:** Temperature coefficient is measured by dividing the change in output voltage over the temperature range by the change in temperature. Separate tests are done for hot and cold:  $T_{MIN}$  to  $25^\circ C$  and  $25^\circ C$  to  $T_{MAX}$ .

**Incremental slope is also measured at  $25^\circ C$ .** For LT1031BMH, the 5ppm/ $^\circ C$  drift specification is for  $-25^\circ C$  to  $85^\circ C$ . Drift over the full  $-55^\circ C$  to  $125^\circ C$  range is guaranteed to 7ppm/ $^\circ C$ .

**Note 4:** Line and load regulation are measured on a pulse basis. Output changes due to die temperature change must be taken into account separately. Package thermal resistance is 150 $^\circ C/W$ .

**Note 5:** Shunt mode regulation is measured with the input open. With the input connected, shunt mode current can be reduced to 0mA. Load regulation will remain the same.

**Note 6:** Temperature drift is guaranteed from  $-25^\circ C$  to  $85^\circ C$  on LH0070.

**Note 7:** See curve for guaranteed minimum  $V_{IN}$  versus  $I_{OUT}$ .

**Note 8:** Guaranteed by design.

## CROSS REFERENCE

The following cross reference guide may be used to select LT1031 grades which meet or exceed output voltage, temperature drift, load and line regulation, and output current specifications of the AD581 reference. Parameters such as noise, hysteresis, and long term stability will be significantly better for all LT1031 grades compared to the AD581.

CROSS REFERENCE GUIDE/LT1031 TO AD581	
AD581J	order LT1031DCH
AD581K	order LT1031CCH
AD581L	order LT1031BCH
A0581S	order LT1031DMH
A0581U	order LT1031BMH

## TYPICAL PERFORMANCE CHARACTERISTICS

**Ripple Rejection**

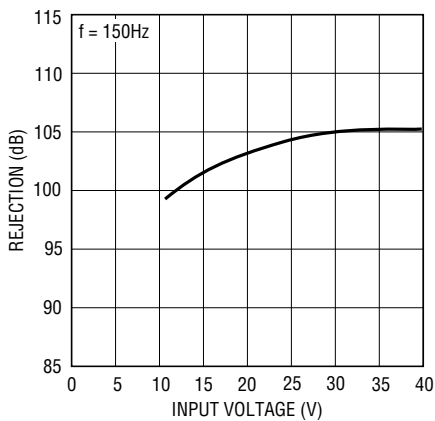

LT1031 • TPC01

**Ripple Rejection**

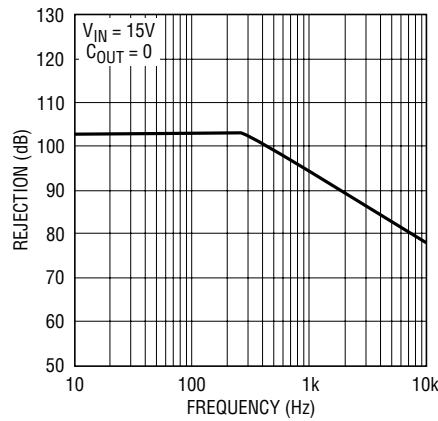

LT1031 • TPC02

**Minimum Input Voltage**

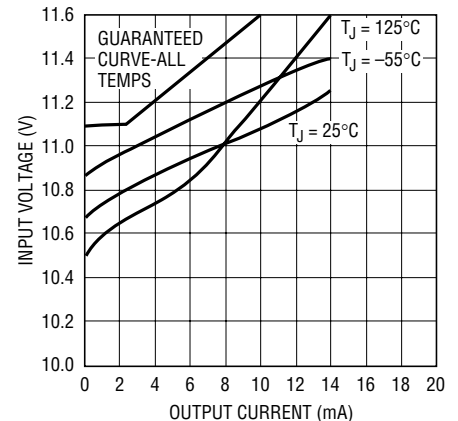

LT1031 • TPC03

**Start-Up (Series Mode)**

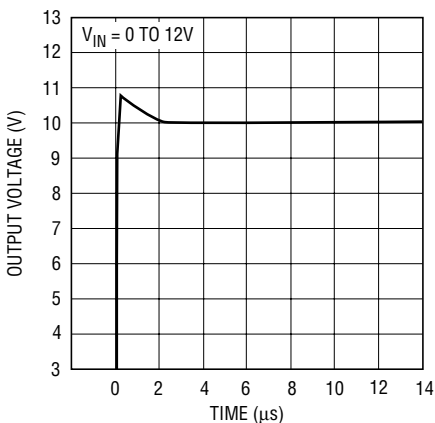

LT1031 • TPC04

**Start-Up (Shunt Mode)**

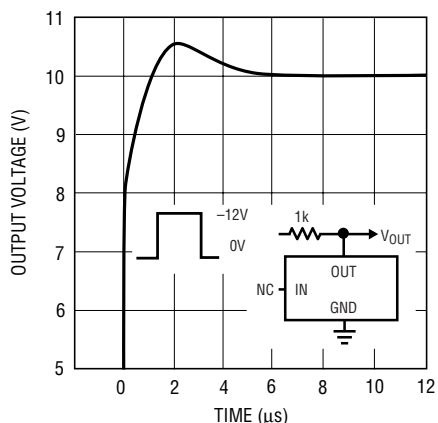

LT1031 • TPC05

**Output Voltage Noise Spectrum**

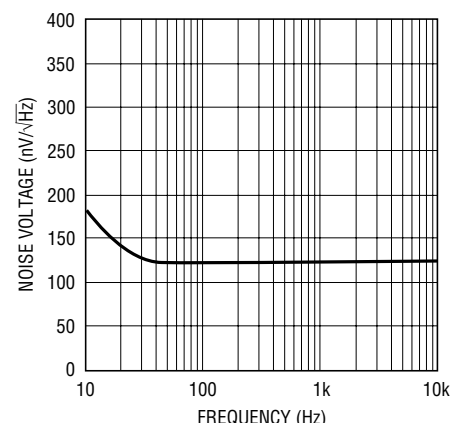

LT1031 • TPC06

# TYPICAL PERFORMANCE CHARACTERISTICS

**Output Voltage Noise**

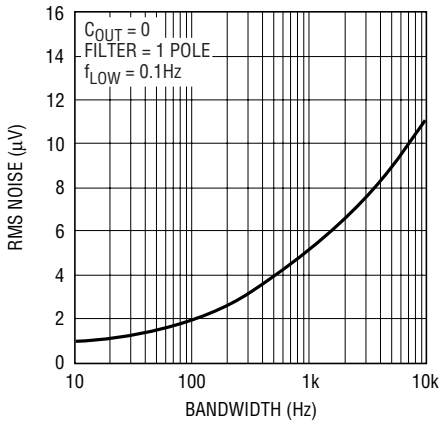

**Load Regulation**

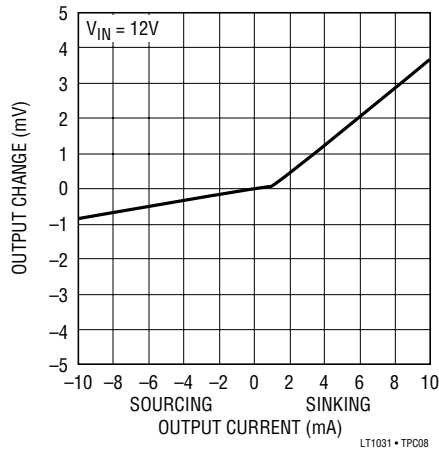

**Output Voltage Temperature**

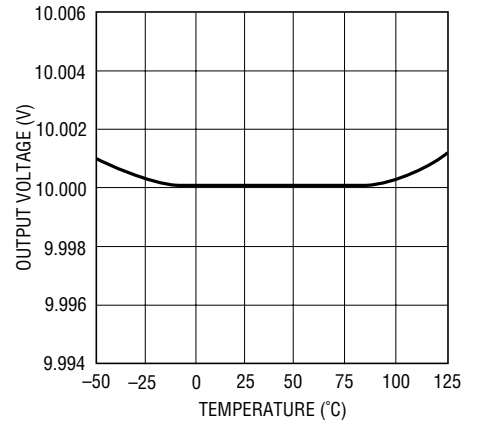

**Input Supply Current**

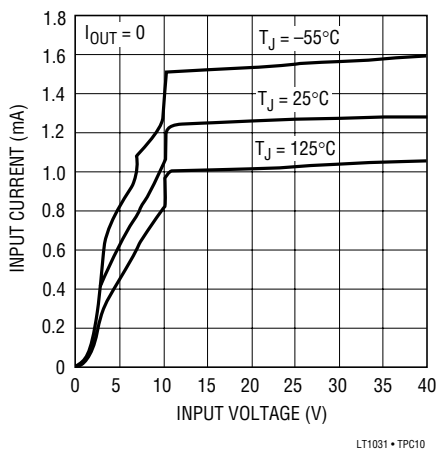

**Shunt Characteristics**

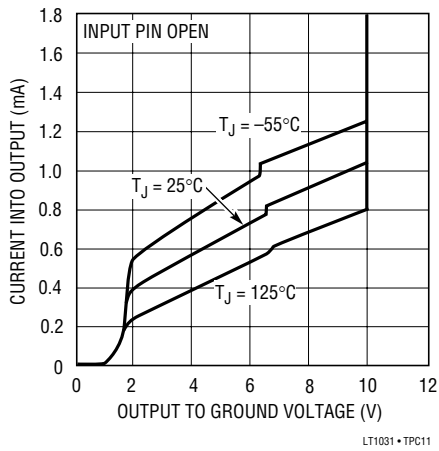

**Shunt Mode Current Limit**

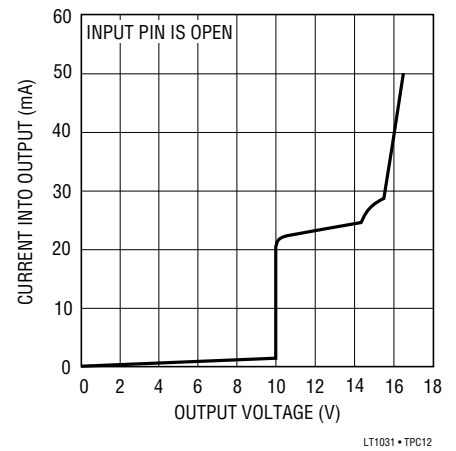

**Thermal Regulation**

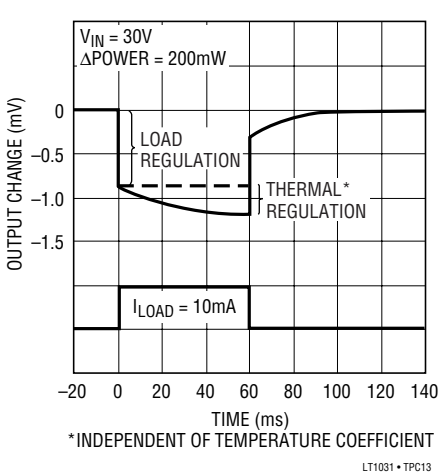

**Load Transient Response**  
 $C_{\text{LOAD}} = 0$

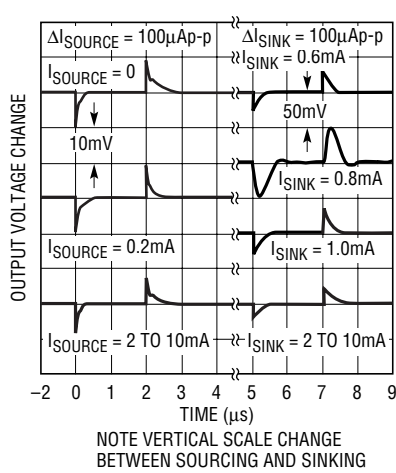

**Load Transient Response**  
 $C_{\text{LOAD}} = 1000\text{pF}$

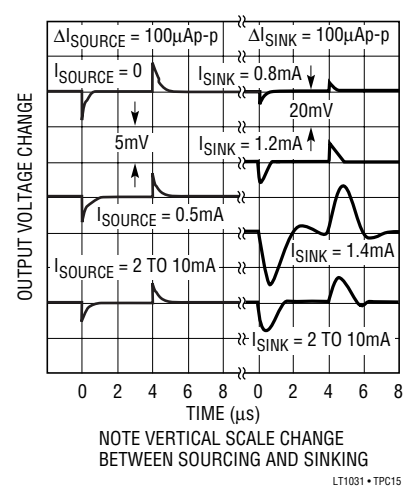

## TYPICAL PERFORMANCE CHARACTERISTICS

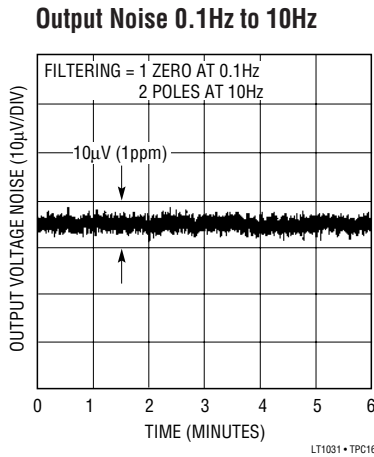

## APPLICATIONS INFORMATION

### Trimming Output Voltage

The LT1031 output can be trimmed by driving the ground pin. The suggested method is shown in the illustration below. A 5Ω resistor is inserted in series with the ground pin. The top of the resistor is supplied current from a trim potentiometer. This technique requires fairly high trim current of up to 1.5mA from the LT1031 or 3.5mA from the -15V supply; however it is necessary to maintain low drift in the reference. Ground pin current changes in the LT1031, with temperature, could be as high as 4µA/°C. This, coupled with the 5Ω external resistor, creates up to 2ppm/°C drift in the reference ( $5\Omega \cdot 4\mu\text{A}/^\circ\text{C} = 20\mu\text{V}/^\circ\text{C} = 2\text{ppm}/^\circ\text{C}$ ). If induced drift higher than this can be tolerated, all resistor values in the trim circuit can be raised proportionately to reduce current drain.

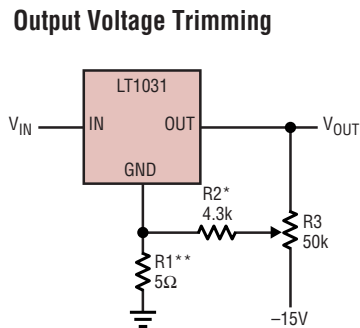

\* CAN BE INCREASED TO 5.6k FOR  
LT1031B AND LH0070-2

\*\* INCREASE TO 10Ω FOR LT1031D

LT1031 • TA04

### Effect of Reference Drift on System Accuracy

A large portion of the temperature drift error budget in many systems is the system reference voltage. The graph below indicates the maximum temperature coefficient allowable if the reference is to contribute no more than 1/2LSB error to the overall system performance. The example shown is a 12-bit system designed to operate over a temperature range from 25°C to 65°C. Assuming the system calibration is performed at 25°C, the temperature span is 40°C. The graph shows that the temperature coefficient of the reference must be no worse than 3ppm/°C if it is to contribute less than 1/2LSB error. For this reason, the LT1031 has been optimized for low drift.

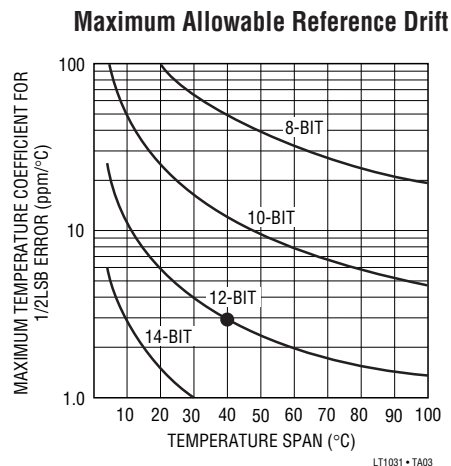

## APPLICATIONS INFORMATION

### Capacitive Loading and Transient Response

The LT1031 is stable with all capacitive loads, but for optimum settling with load transients, output capacitance should be under 1000pF. The output stage of the reference is class AB with a fairly low idling current. This makes transient response worst-case at light load currents. Because of internal current drain on the output, actual worst-case occurs at  $I_{LOAD} = 1.4\text{mA}$  (sinking). Significantly better load transient response is obtained by moving slightly away from these points. See Load Transient Response curves for details. In general, best transient response is obtained when the output is sourcing current. In critical applications, a 10 $\mu\text{F}$  solid tantalum capacitor with several ohms in series provides optimum output bypass.

### Kelvin Connections

Although the LT1031 does not have true force/sense capability at its outputs, significant improvements in ground loop and line loss problems can be achieved with proper hook-up. In series mode operation, the ground pin of the LT1031 carries only  $\approx 1\text{mA}$  and can be used as a sense line, greatly reducing ground loop and loss problems on the low side of the reference. The high side supplies load current so line resistance must be kept low. Twelve feet of #22 gauge hook up wire or 1 foot of 0.025 inch printed circuit trace will create 2mV loss at 10mA output current. This is equivalent to 1LSB in a 10V, 12-bit system.

The following circuits show proper hook-up to minimize errors due to ground loops and line losses. Losses in the output lead can be greatly reduced by adding a PNP boost transistor if load currents are 5mA or higher. R2 can be added to further reduce current in the output sense lead.

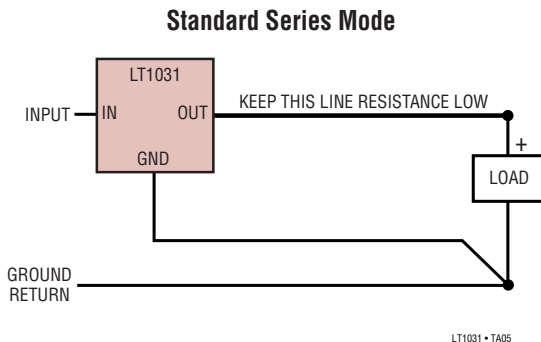

### Series Mode with Boost Transistor

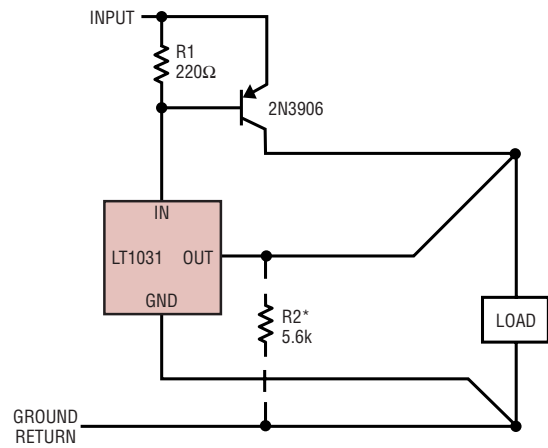

\*OPTIONAL—REDUCES CURRENT IN OUTPUT SENSE LEAD

LT1031 • TA06

### Effects of Air Movement on Low Frequency Noise

The LT1031 has very low noise because of the buried zener used in its design. In the 0.1Hz to 10Hz band, peak-to-peak noise is about 0.5ppm of the DC output. To achieve this low noise, however, care must be taken to shield the reference from ambient air turbulence. Air movement can create noise because of thermoelectric differences between IC package leads (especially kovar lead TO-5) and printed circuit board materials and/or sockets. Power dissipation in the reference, even though it rarely exceeds 20mW, is enough to cause small temperature gradients in the package leads. Variations in thermal resistance, caused by uneven airflow, create differential lead temperatures, thereby causing thermoelectric voltage noise at the output of the reference. The XY plotter trace shown on the following page dramatically illustrates this effect. The first half of the plot was done with the LT1031 shielded from ambient air with a small foam cup. The cup was then removed for the second half of the trace. Ambient in both cases was a lab environment with no excessive air turbulence from air conditioners, opening/closing doors, etc. Removing the foam cup increases the output noise by almost an order of magnitude in the 0.01Hz to 1Hz band! The kovar leads of the TO-5 (H) package are the primary culprit. Alloy 42 and copper lead frames used on dual-in-line packages are not nearly as sensitive to thermally generated noise because they are intrinsically matched.

## APPLICATIONS INFORMATION

There is nothing magical about foam cups—any enclosure which blocks air flow from the reference will do. Smaller enclosures are better since they do not allow the build-up of internally generated air movement. Naturally, heat generating components external to the reference itself should not be included inside the enclosure.

Noise Induced by Air Turbulence (TO-5 Package)

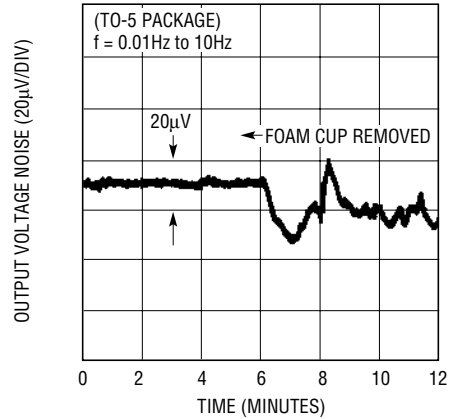

LT1031 • TA07

## APPLICATION CIRCUITS

Negative Series Reference

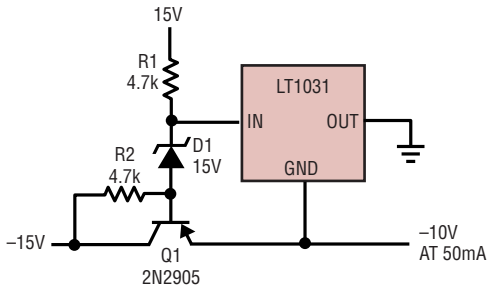

Boosted Output Current with No Current Limit

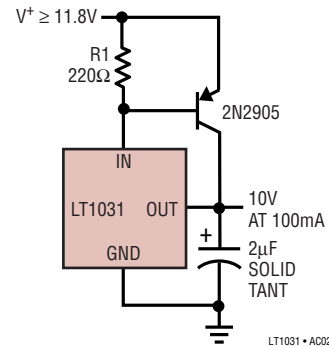

Boosted Output Current with Current Limit

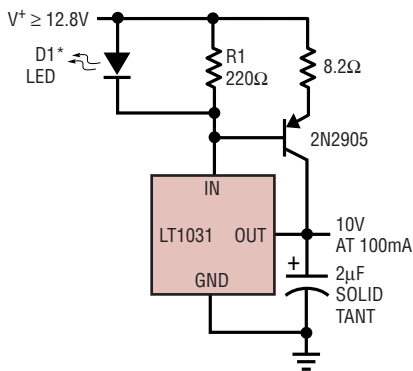

\*GLOWS IN CURRENT LIMIT  
DO NOT OMIT

LT1031 • AC03

Handling Higher Load Currents

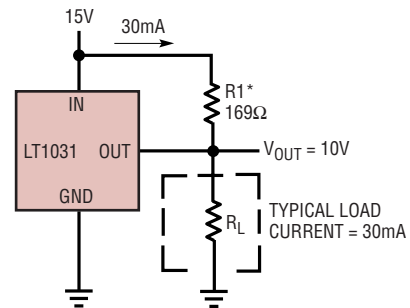

\*SELECT R1 TO DELIVER TYPICAL LOAD CURRENT  
LT1031 WILL THEN SOURCE OR SINK AS NECESSARY  
TO MAINTAIN PROPER OUTPUT. DO NOT REMOVE LOAD,  
AS OUTPUT WILL BE DRIVEN (UNREGULATED) HIGH. LINE  
REGULATION IS DEGRADED IN THIS APPLICATION

LT1031 • AC04

APPLICATION CIRCUITS

Strain Gauge Conditioner for 350Ω Bridge

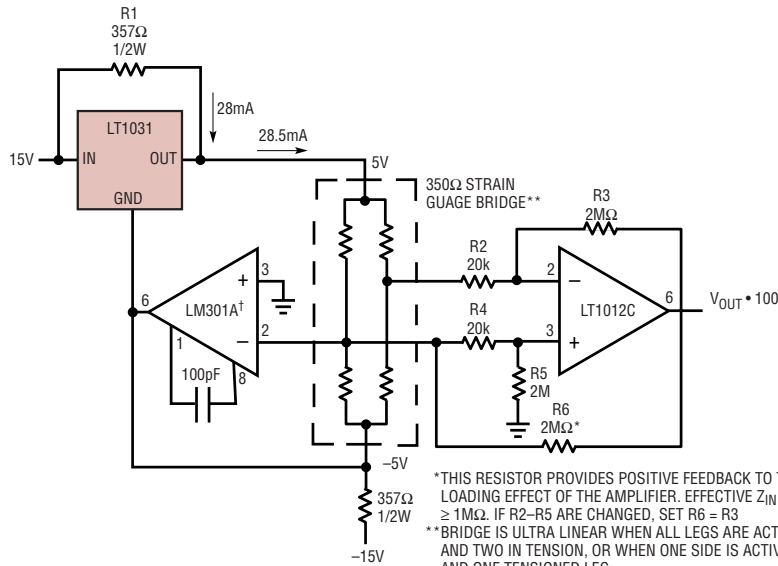

\* THIS RESISTOR PROVIDES POSITIVE FEEDBACK TO THE BRIDGE TO ELIMINATE LOADING EFFECT OF THE AMPLIFIER. EFFECTIVE  $Z_{IN}$  OF AMPLIFIER STAGE IS  $\geq 1M\Omega$ . IF R2-R5 ARE CHANGED, SET R6 = R3  
 \*\* BRIDGE IS ULTRA LINEAR WHEN ALL LEGS ARE ACTIVE, TWO IN COMPRESSION AND TWO IN TENSION, OR WHEN ONE SIDE IS ACTIVE WITH ONE COMPRESSED AND ONE TENSIONED LEG  
 † OFFSET AND DRIFT OF LM301A ARE VIRTUALLY ELIMINATED BY DIFFERENTIAL CONNECTION OF LT1012C

LT1031 • AC05

Ultralinear Platinum Temperature Sensor\*

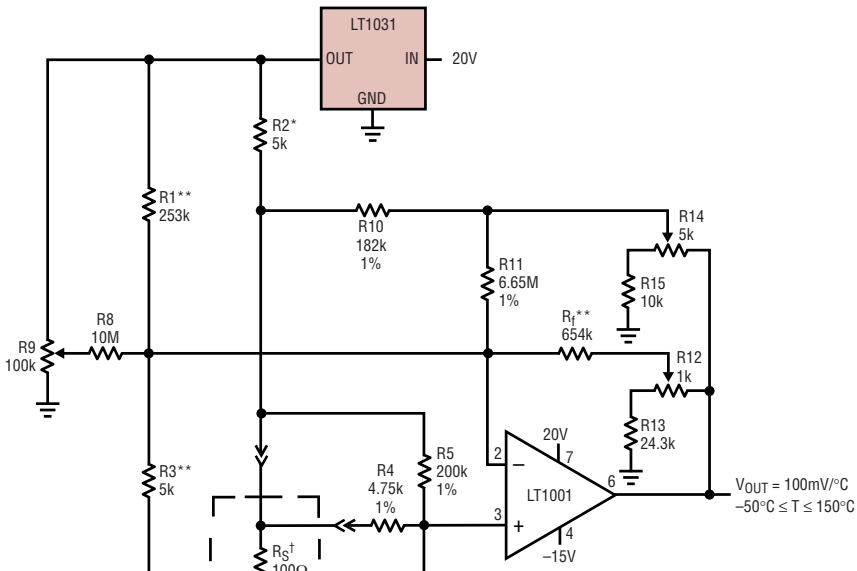

† STANDARD INDUSTRIAL 100Ω PLATINUM 4-WIRE SENSOR, ROSEMOUNT 78S, OR EQUIVALENT.  $\alpha = 0.00385$   
 TRIM R9 FOR  $V_{OUT} = 0$  AT 0°C  
 TRIM R12 FOR  $V_{OUT} = 10V$  AT 100°C  
 TRIM R14 FOR  $V_{OUT} = 5V$  AT 50°C  
 USE TRIM SEQUENCE AS SHOWN. TRIMS ARE NON-INTERACTIVE SO THAT ONLY ONE TRIM SEQUENCE IS NORMALLY REQUIRED.  
 \* FEEDBACK LINEARIZES OUTPUT TO  $\pm 0.005^\circ C$  FROM  $-50^\circ C$  TO  $150^\circ C$   
 \*\* WIREWOUND RESISTORS WITH LOW TC

LT1031 • AC06

**APPLICATION CIRCUITS**

**2-Pole Lowpass Filtered Reference**

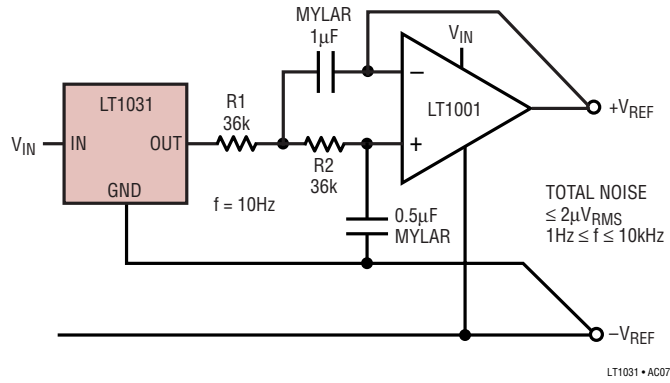

**Negative Shunt Reference Driven by Current Source**

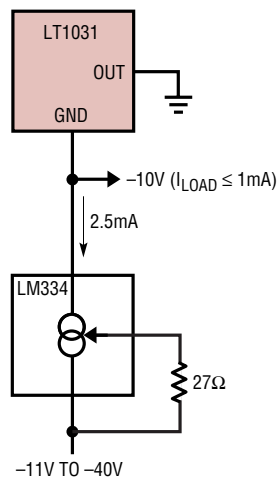



**PACKAGE DESCRIPTION**

**H Package**  
**3-Lead TO-39 Metal Can**  
 (Reference LTC DWG # 05-08-1330)

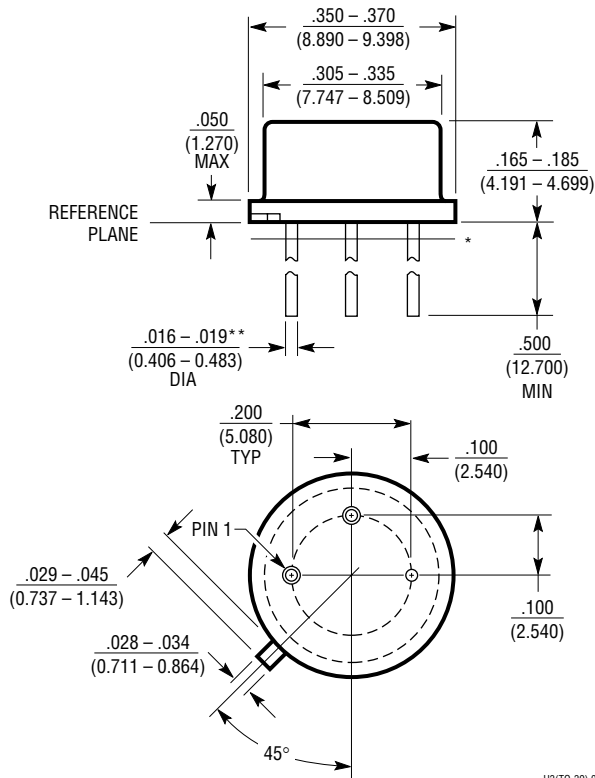

H3(TO-39) 0801

\* LEAD DIAMETER IS UNCONTROLLED BETWEEN THE REFERENCE PLANE AND .050" BELOW THE REFERENCE PLANE

\*\* FOR SOLDER DIP LEAD FINISH, LEAD DIAMETER IS .016 - .024 (0.406 - 0.610)

## Looking for pricing, stock, or lifecycle information?

Click below to explore more details on WIN SOURCE:

 [View LT1031BCH on WIN SOURCE](#)

 [Analog Devices Inc. Information](#)

## Optimize Your Supply Chain with WIN SOURCE Solutions

-  Global Sourcing Solution
-  Obsolete Management
-  Cost Control Management
-  Shortage Management
-  Alternative Solution
-  Excess Inventory Management