

# Single-chip Type with Built-in FET Switching Regulator Series

## High-efficiency Step-up/down Switching Regulator with Built-in Power MOSFET

**BD8301MUV**

No.09027ECT07

### ●General Description

ROHM's highly-efficient step-up/down switching regulator BD8301MUV produces step-up/down output including 3.3 V from 1 cell of lithium battery with just one coil.

This IC adopts an original step-up/down drive system and creates a higher efficient power supply than conventional Sepic-system or H-bridge system switching regulators.

### ●Features

- 1) Highly-efficient step-up/down DC/DC converter to be constructed just with one inductor.
- 2) Input voltage                    2.5 V - 5.5 V
- 3) Output current                1 A at 3.3 V  
                                          800 mA at 5.0 V
- 4) Incorporates soft-start function.
- 5) Incorporates timer latch system short protecting function.
- 6) High heat radiation surface mounted package                    VQFN020V4040

### ●Application

General portable equipment like portable audio or DSC/DVC

### ●Absolute Maximum Ratings

Parameter	Symbol	Ratings	Unit
Maximum applied power voltage	Vcc,PVcc	7.0	V
Maximum input current	Iinmax	2.0	A
Maximum input voltage	Lx1	7.0	V
	Lx2	7.0	V
Power dissipation	Pd	700	mW
Operating temperature range	Topr	-25 to +85	°C
Storage temperature range	Tstg	-55 to +150	°C
Junction temperature	Tjmax	150	°C

\*1 When installed on a 70.0 mm x 70.0 mm x 1.6 mm glass epoxy board. The rating is reduced by 5.6 mW/°C at Ta = 25°C or more.

### ●Operating Conditions (Ta = 25°C)

Parameter	Symbol	Voltage range	Unit
Power supply voltage	Vcc	2.5 to 5.5	V
Output voltage	OUT	2.8 to 5.2	V

## ●Electrical Characteristics

(Unless otherwise specified, Ta = 25 °C, Vcc = 3.7 V)

Parameter	Symbol	Target Value			Unit	Conditions	
		Min	Typ	Max			
[Low voltage input malfunction preventing circuit]							
Detection threshold voltage	VUV	-	2.25	2.45	V	Vcc monitor	
Hysteresis range	$\Delta VUV_{hy}$	50	100	150	mV		
[Oscillator]							
Oscillation frequency	fosc	0.8	1.0	1.2	MHz	RT=47k $\Omega$	
[Error AMP]							
INV threshold voltage	VINV	0.790	0.800	0.810	V		
Input bias current	IINV	-50	0	50	nA	Vcc=7.0V , VINV=3.5V	
Soft-start time	Tss	0.6	1.00	1.4	msec	RT=47k $\Omega$	
Output source current	IEO	10	20	30	$\mu$ A	VINV=0.5V , VFB =1.5V	
Output sink current	IEI	0.7	1.5	3.0	mA	VINV=1.1V , VFB =1.5V	
[PWM comparator]							
LX1 Max Duty	Dmax1	-	-	100	%		
LX2 Max Duty	Dmax2	77	85	93	%		
[Output]							
LX1 PMOS ON resistance	RON1p	-	120	200	m $\Omega$	VGS=3.0V	
LX1 NMOS ON resistance	RON1n	-	100	160	m $\Omega$	VGS=3.0V	
LX2 PMOS ON resistance	RON2p	-	120	200	m $\Omega$	VGS=3.0V	
LX2 NMOS ON resistance	RON2n	-	100	160	m $\Omega$	VGS=3.0V	
LX1 leak current	I leak1	-1	0	1	$\mu$ A		
LX2 leak current	I leak2	-1	0	1	$\mu$ A		
[STB]							
STB pin ontrl voltage	Operation	VSTBH	1.5	-	5.5	V	
	No-operation	VSTBL	-0.3	-	0.3	V	
STB pin pull-down resistance	RSTB	250	400	700	k $\Omega$		
[Circuit current]							
Standby current	VCC pin	ISTB1	-	-	1	$\mu$ A	
	PVCC pin	ISTB2	-	-	1	$\mu$ A	
	VOOUT pin	ISTB3	-	-	1	$\mu$ A	
Circuit current at operation VCC	Icc1	-	500	750	$\mu$ A	VINV=1.2V	
Circuit current at operation PVCC	Icc2	-	10	20	$\mu$ A	VINV=1.2V	

●Description of Pins

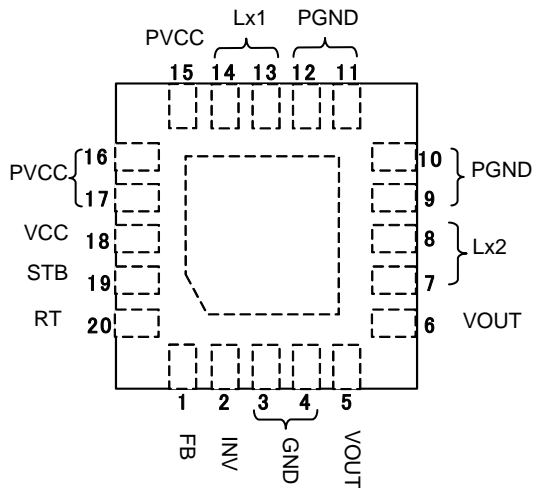

Pin No.	Pin Name	Function
1	FB	Error AMP output terminal
2	INV	Error AMP input terminal
3~4	GND	Ground terminal
5~6	VOUT	Output voltage terminal
7~8	Lx2	Output side coil connecting terminal
9~12	PGND	Power transistor ground terminal
13~14	Lx1	Input side coil connecting terminal
15~17	PVCC	DC/DC converter input terminal
18	VCC	Control part power supply input terminal
19	STB	ON/OFF terminal
20	RT	Oscillation frequency set terminal

Fig.1 Pin layout

●Block Diagram

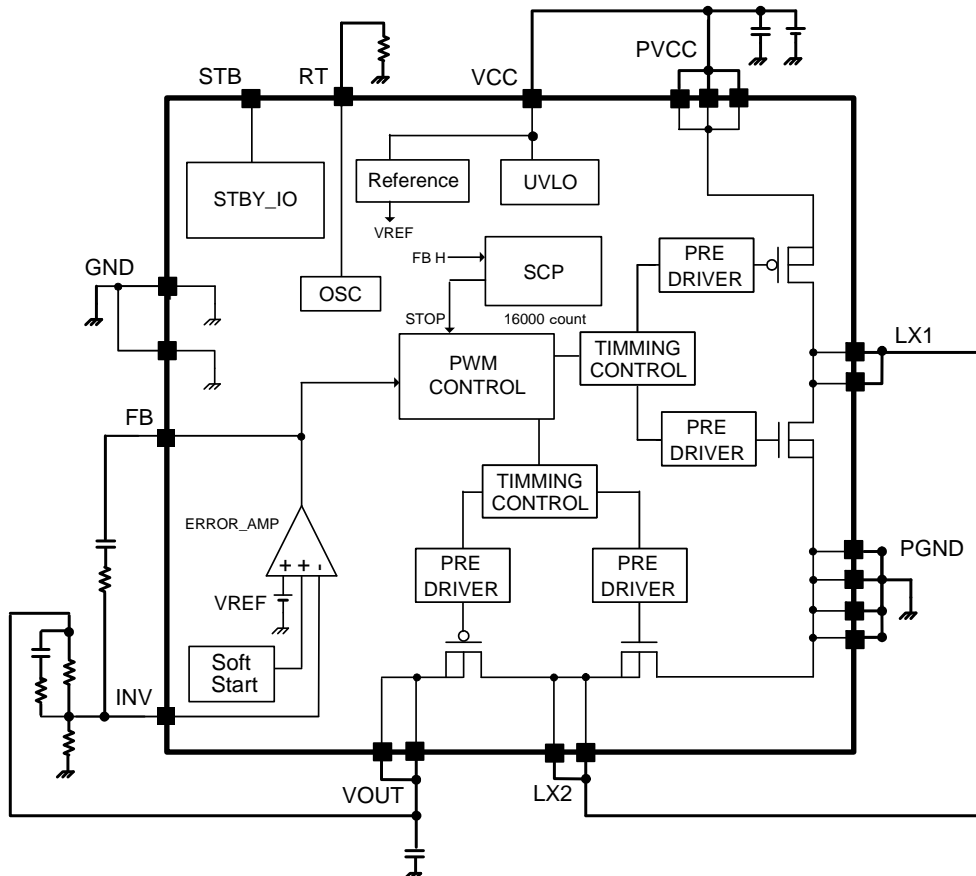

Fig.2 Block diagram

## ●Description of Blocks

### 1.VREF

This block generates ERROR AMP reference voltage.  
The reference voltage is 0.8 V.

### 2.UVLO

Circuit for preventing low voltage malfunction  
Prevents malfunction of the internal circuit at activation of the power supply voltage or at low power supply voltage.  
Monitors VCC pin voltage to turn off all output FET and DC/DC converter output when VCC voltage is lower than 2.2 V, and reset the timer latch of the internal SCP circuit and soft-start circuit.

### 3.SCP

Timer latch system short-circuit protection circuit  
When the INV pin is the set 0.8 V or lower voltage, the internal SCP circuit starts counting.  
The internal counter is in synch with OSC; the latch circuit activates after the counter counts about 16000 oscillations to turn off DC/DC converter output (about 16 msec when  $RT = 47k\Omega$ ).  
To reset the latch circuit, turn off the STB pin once. Then, turn it on again or turn on the power supply voltage again.

### 4.OSC

Oscillation circuit to change frequency by external resistance of the RT pin (20 pin).  
When  $RT = 47 k\Omega$ , operation frequency is set at 1 MHz.

### 5.ERROR AMP

Error amplifier for detecting output signals and output PWM control signals  
The internal reference voltage is set at 0.8 V.

### 6.PWM COMP

Voltage-pulse width converter for controlling output voltage corresponding to input voltage  
Comparing the internal SLOPE waveform with the ERROR AMP output voltage, PWM COMP controls the pulse width and outputs to the driver.  
Max Duty and Min Duty are set at the primary side and the secondary side of the inductor respectively, which are as follows:

Primary side (Lx1)	Max Duty : 100 %,
	Min Duty : 0 %
Secondary side (Lx2)	Max Duty : 100 %,
	Min Duty : About 15 %

### 7.SOFT START

Circuit for preventing in-rush current at startup by bringing the output voltage of the DC/DC converter into a soft-start  
Soft-start time is in synch with the internal OSC, and the output voltage of the DC/DC converter reaches the set voltage after about 1000 oscillations (About 1 msec when  $RT = 47 k\Omega$ ).

### 8.PRE DRIVER

CMOS inverter circuit for driving the built-in Pch/Nch FET  
Dead time is provided for preventing feedthrough during switching.  
The dead time is set at about 15 nsec for each individual SWs.

### 9. STBY\_IO

Voltage applied on STB pin (19 pin) to control ON/OFF of IC  
Turned ON when a voltage of 1.5 V or higher is applied and turned OFF when the terminal is open or 0 V is applied.  
Incorporates approximately 400 k $\Omega$  pull-down resistance.

### 10. Pch/Nch FET SW

Built-in SW for switching the coil current of the DC/DC converter. Pch FET is about 120 m $\Omega$  and Nch is 100 m $\Omega$ .  
Since the current rating of this FET is 2 A, it should be used within 2 A in total including the DC current and ripple current of the coil.

●Reference Data

(Unless otherwise specified, Ta = 25°C, VCC = 3.7 V)

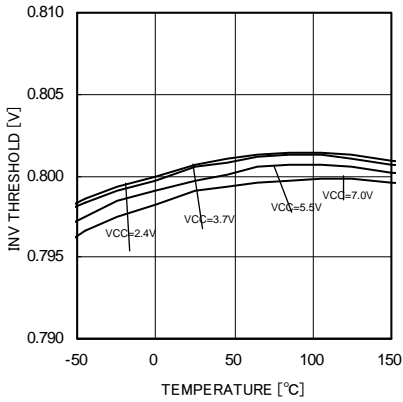

Fig.3 INV threshold

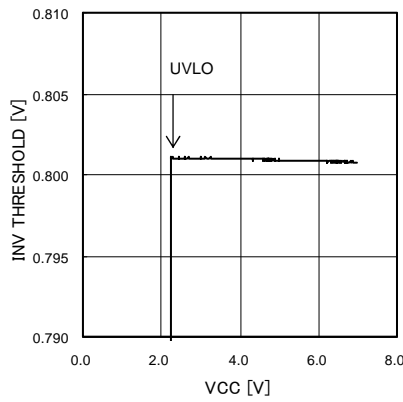

Fig.4. INV threshold (power supply property)

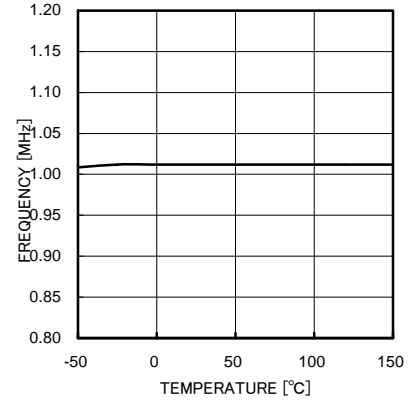

Fig.5 Oscillation frequency

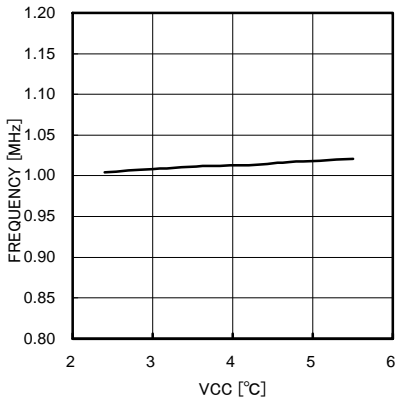

Fig.6 Oscillation frequency (power supply property)

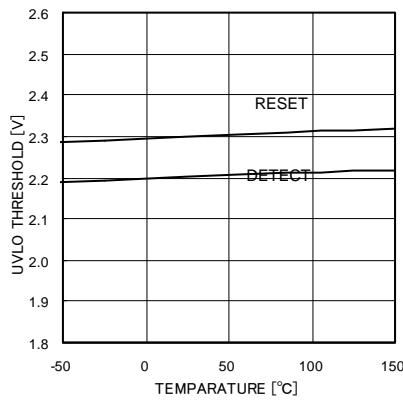

Fig.7 UVLO threshold

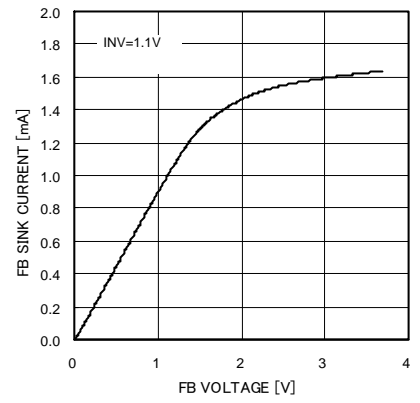

Fig.8 FB sink current

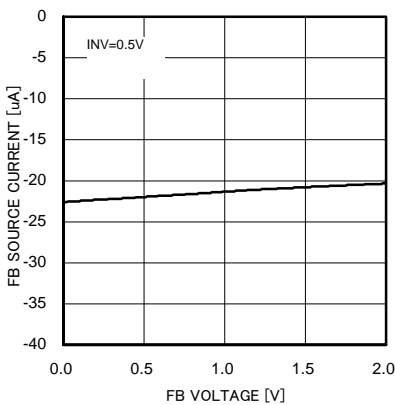

Fig.9 FB source current

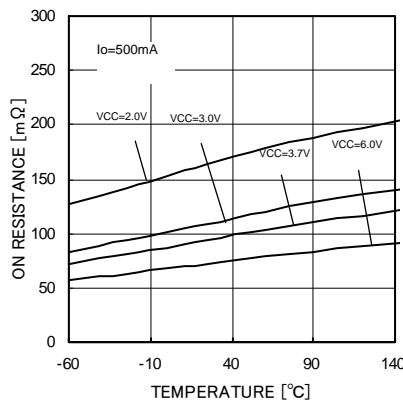

Fig.10 Lx1 Pch FET ON resistance

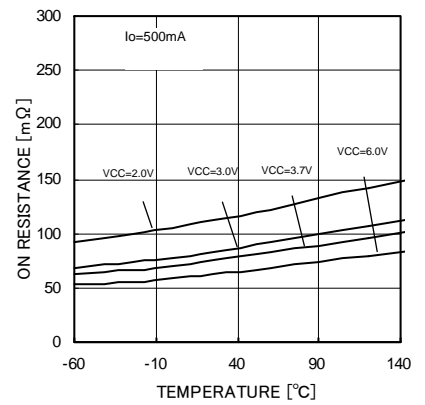

Fig.11 Lx1 Nch FET ON resistance

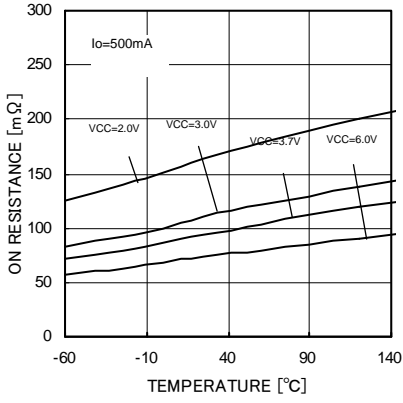

Fig.12 Lx2 Pch FET ON resistance

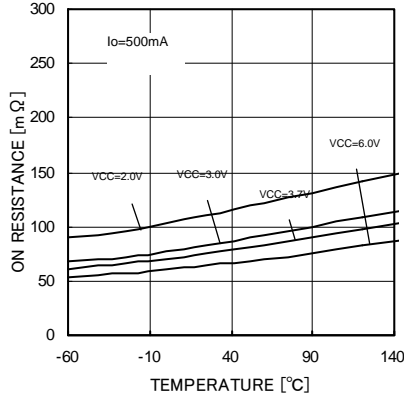

Fig.13 Lx2 Nch FET ON resistance

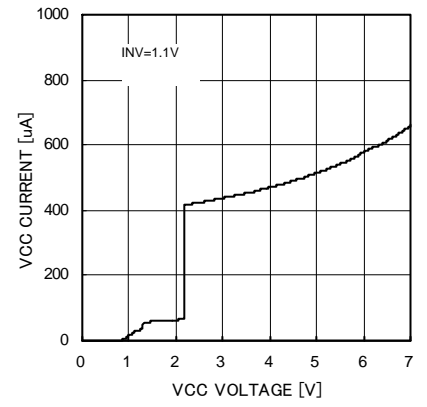

Fig.14 VCC input current

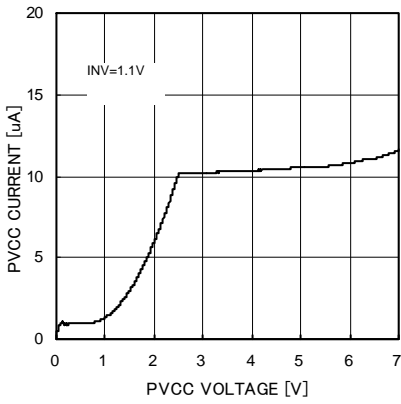

Fig.15 PVCC input current

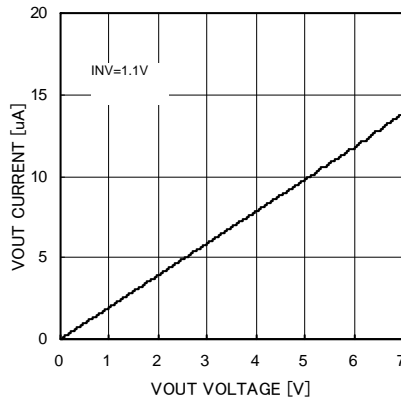

Fig.16 VOUT input current

● Example of Application Input: 2.8 to 5.5 V, output: 3.3 V / 1.0 A, frequency 600 kHz

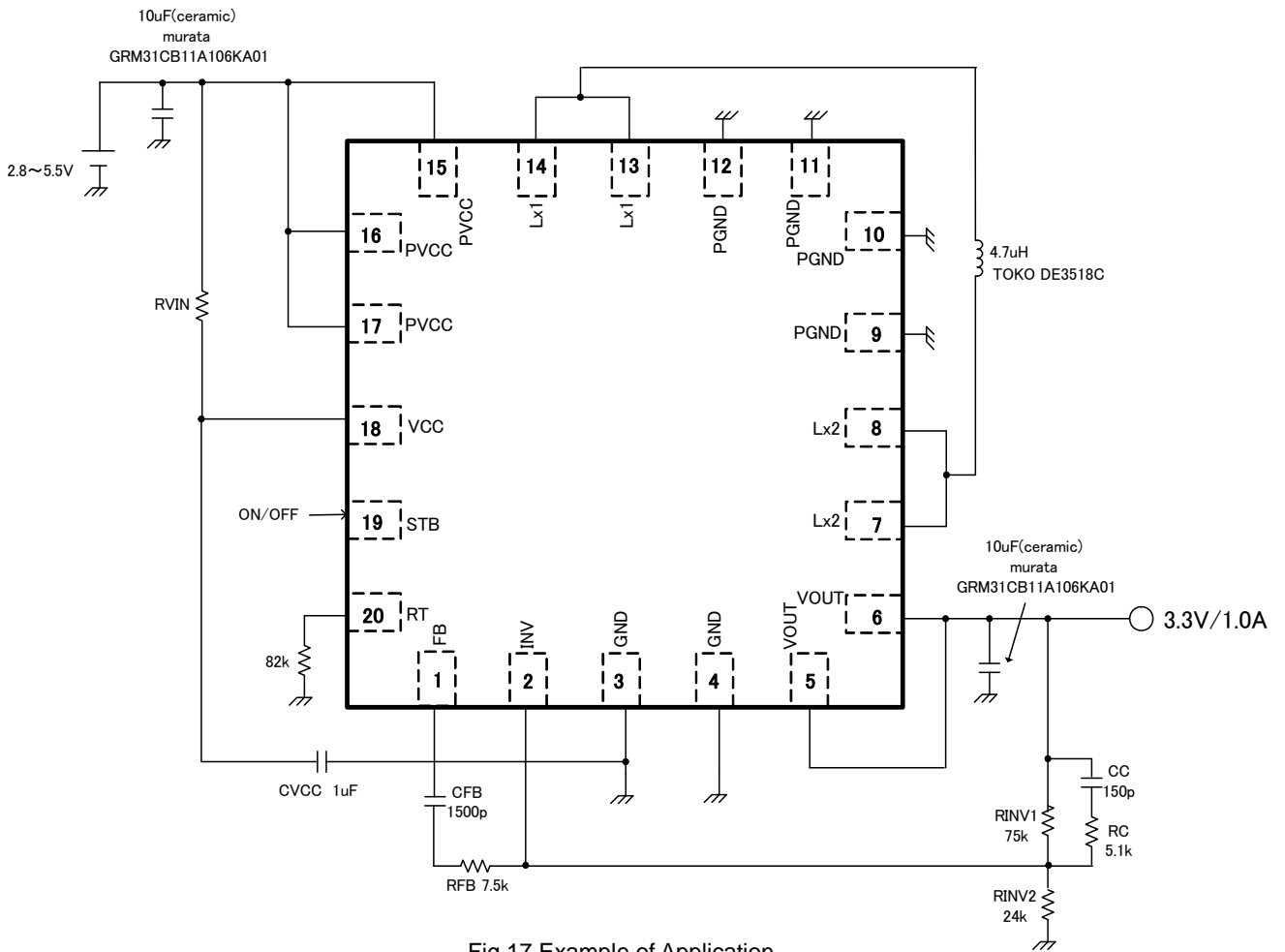

Fig.17 Example of Application

● Example of Board Layout

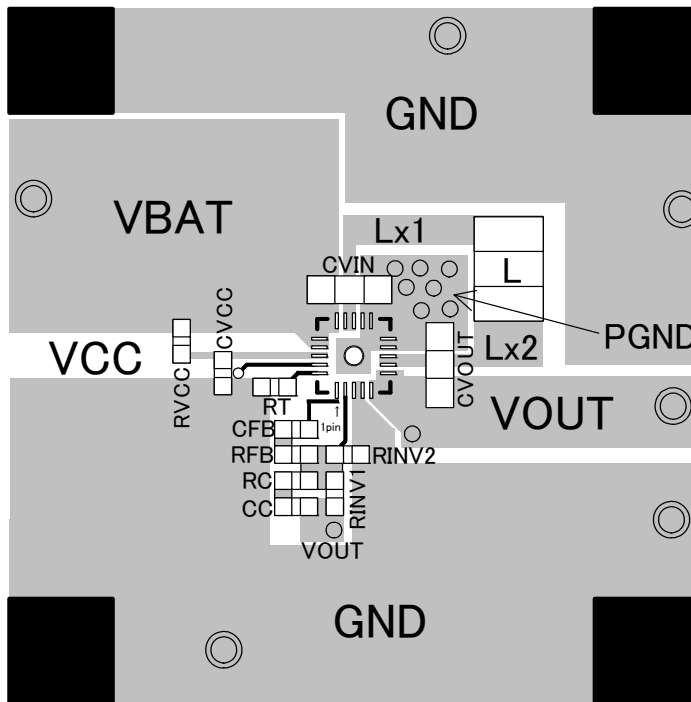

Fig.18 Example of Board Layout

●Reference Application Data

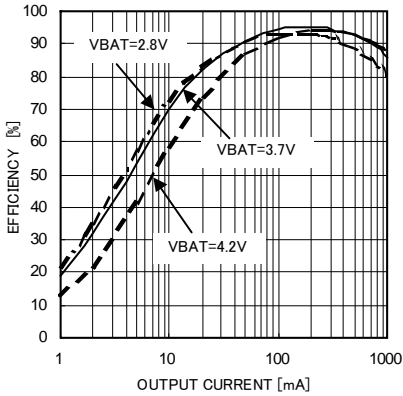

Fig.19 Power conversion efficiency

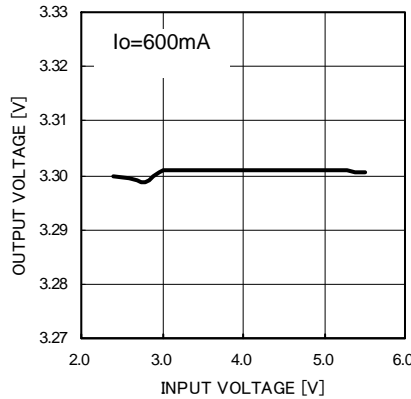

Fig.20 Line regulation

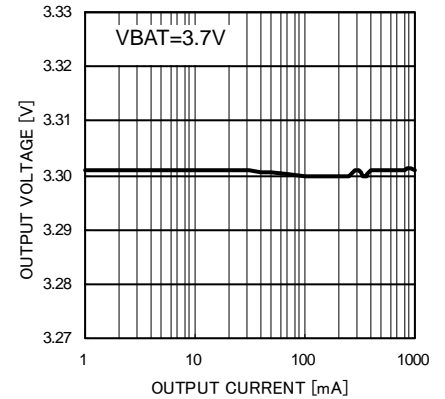

Fig.21 Load regulation

●Selection of Parts for Applications

(1) Output inductor

A shielded inductor that satisfies the current rating (current value, Ipeak as shown in the drawing below) and has a low DCR (direct current resistance component) is recommended.

Inductor values affect output ripple current greatly.

Ripple current can be reduced as the coil L value becomes larger and the switching frequency becomes higher as the equations shown below.

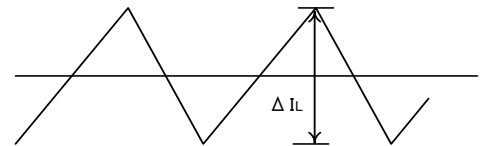

Fig. 22 Ripple current

$$I_{peak} = I_{out} \times (V_{out}/V_{in}) / \eta + \Delta I_L / 2 \text{ [A]} \quad (1)$$

$$\Delta I_L = \frac{(V_{in} - V_{out})}{L} \times \frac{V_{out}}{V_{in}} \times \frac{1}{f} \text{ [A]} \text{ (in step-down mode)} \quad (2)$$

$$\Delta I_L = \frac{|(V_{in} - V_{out})|}{L} \times \frac{V_{out} \times 2 \times 0.85}{(V_{in} + V_{out})} \times \frac{1}{f} \text{ [A]} \text{ (in step-up/down mode)} \quad (3)$$

$$\Delta I_L = \frac{(V_{out} - V_{in})}{L} \times \frac{V_{in}}{V_{out}} \times \frac{1}{f} \text{ [A]} \text{ (in step-up mode)} \quad (4)$$

(η: Efficiency, ΔIL: Output ripple current, f: Switching frequency)

As a guide, output ripple current should be set at about 20 to 50% of the maximum output current.

\* Current over the coil rating flowing in the coil brings the coil into magnetic saturation, which may lead to lower efficiency or output oscillation. Select an inductor with an adequate margin so that the peak current does not exceed the rated current of the coil.

(2) Output capacitor

A ceramic capacitor with low ESR is recommended for output in order to reduce output ripple.

There must be an adequate margin between the maximum rating and output voltage of the capacitor, taking the DC bias property into consideration.

Output ripple voltage when ceramic capacitor is used is obtained by the following equation.

$$V_{pp} = \Delta I_L \times \frac{1}{2\pi \times f \times C_o} + \Delta I_L \times R_{ESR} \quad [V] \quad \dots (5)$$

Setting must be performed so that output ripple is within the allowable ripple voltage.

(3) Setting of oscillation frequency

Oscillation frequency can be set using a resistance value connected to the RT pin (1 pin).

Oscillation frequency is set at 1 MHz when RT = 47 kΩ, and frequency is inversely proportional to RT value.

See Fig. 23 for the relationship between RT and frequency.

Soft-start time changes along with oscillation frequency.

See Fig. 24 for the relationship between RT and soft-start time.

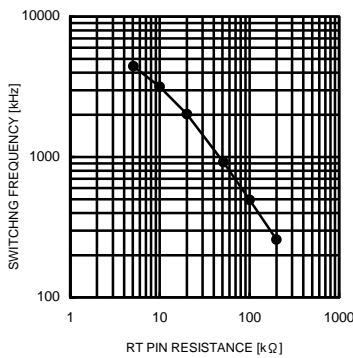

Fig. 23 Oscillation frequency – RT pin resistance

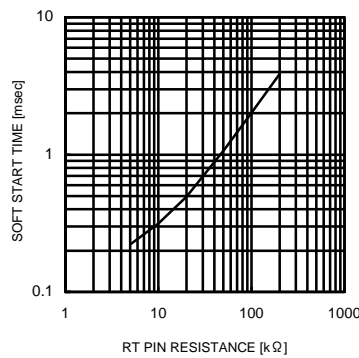
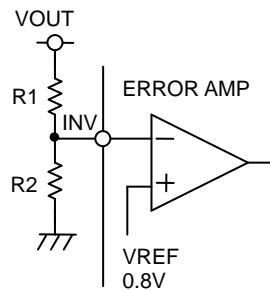

Fig. 24 Soft-start time – RT pin resistance

\* Note that the above example of frequency setting is just a design target value, and may differ from the actual equipment.

(4) Output voltage setting

The internal reference voltage of the ERROR AMP is 0.8 V. Output voltage should be obtained by referring to Equation (8) of Fig. 25.



$$V_o = \frac{(R1+R2)}{R2} \times 0.8 [V] \quad \dots (8)$$

Fig. 25 Setting of feedback resistance

(5) Determination of phase compensation

Condition for stable application

The condition for feedback system stability under negative feedback is as follows:

- Phase delay is 135° or less when gain is 1 (0 dB) (Phase margin is 45° or higher)

Since DC/DC converter application is sampled according to the switching frequency, the GBW of the whole system (frequency at which gain is 0 dB) must be set to be equal to or lower than 1/5 of the switching frequency.

In summary, target property of applications is as follows:

- Phase delay must be 135° or lower when gain is 1 (0 dB) (Phase margin is 45° or higher).
- The GBW at that time (frequency when gain is 0 dB) must be equal to or lower than 1/5 of the switching frequency.

For this reason, switching frequency must be increased to improve responsiveness.

One of the points to secure stability by phase compensation is to cancel secondary phase delay (-180°) generated by LC resonance by the secondary phase lead (i.e. put two phase leads).

Since GBW is determined by the phase compensation capacitor attached to the error amplifier, when it is necessary to reduce GBW, the capacitor should be made larger.

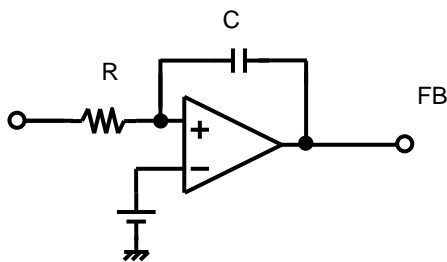
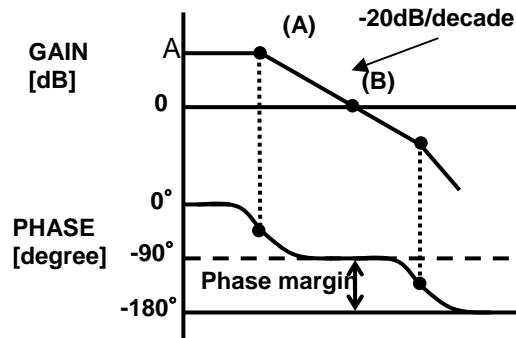

Fig.26 General integrator

Error AMP is a low-pass filter because phase compensation such as (1) and (2) is performed. For DC/DC converter application, R is a parallel feedback resistance.



$$\text{Point (A) } f_p = \frac{1}{2\pi R C A} \quad [\text{Hz}] \quad (9)$$

$$\text{Point (B) } f_{GBW} = \frac{1}{2\pi R C} \quad [\text{Hz}] \quad (10)$$

Fig.27 Frequency property of integrator

Phase compensation when output capacitor with low ESR such as ceramic capacitor is used is as follows:

When output capacitor with low ESR (several tens of mΩ) is used for output, secondary phase lead (two phase leads) must be put to cancel secondary phase lead caused by LC.

One of the examples of phase compensation methods is as follows:

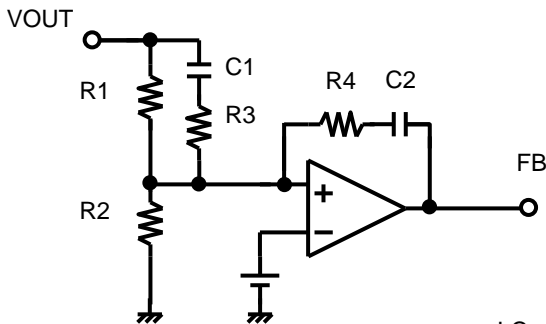

$$\text{Phase lead } f_{z1} = \frac{1}{2\pi R1 C1} \quad [\text{Hz}] \quad (11)$$

$$\text{Phase lead } f_{z2} = \frac{1}{2\pi R4 C2} \quad [\text{Hz}] \quad (12)$$

$$\text{Phase delay } f_{p1} = \frac{1}{2\pi R3 C1} \quad [\text{Hz}] \quad (13)$$

$$\text{LC resonance frequency} = \frac{1}{2\pi \sqrt{LC}} \quad [\text{Hz}] \quad (14)$$

Fig.28 Example of setting of phase compensation

For setting of phase-lead frequency, both of them should be put near LC resonance frequency.

When GBW frequency becomes too high due to the secondary phase lead, it may get stabilized by setting the primary phase delay to a frequency slightly higher than the LC resonance frequency by R3 to compensate it.

● I/O Equivalence Circuit

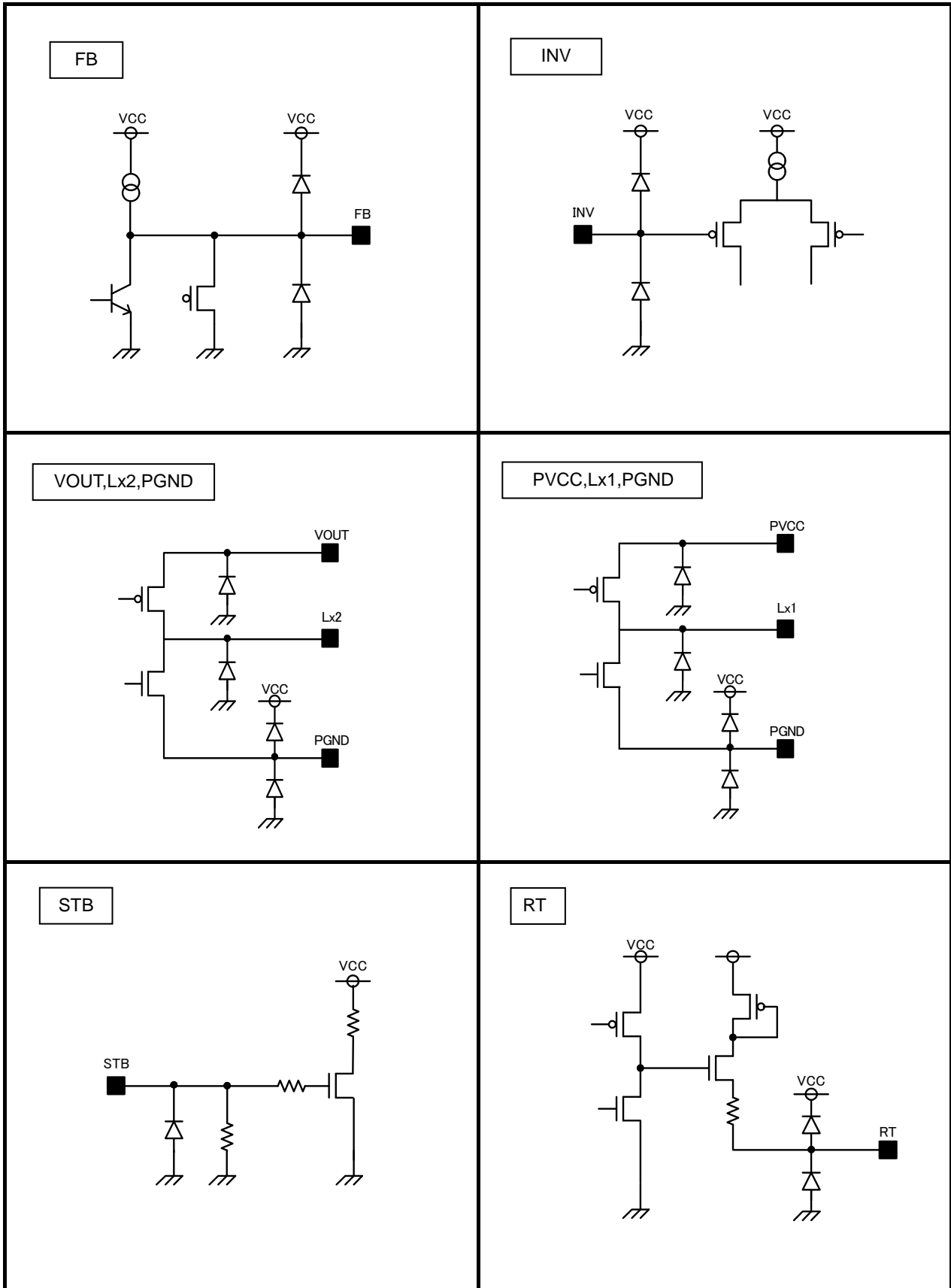

Fig.29 I/O Equivalence Circuit

●Precautions for Use

1) Absolute Maximum Rating

We dedicate much attention to the quality control of these products, however the possibility of deterioration or destruction exists if the impressed voltage, operating temperature range, etc., exceed the absolute maximum ratings. In addition, it is impossible to predict all destructive situations such as short-circuit modes, open circuit modes, etc. If a special mode exceeding the absolute maximum rating is expected, please review matters and provide physical safety means such as fuses, etc.

2) GND Potential

Keep the potential of the GND pin below the minimum potential at all times.

3) Thermal Design

Work out the thermal design with sufficient margin taking power dissipation (Pd) in the actual operation condition into account.

4) Short Circuit between Pins and Incorrect Mounting

Attention to IC direction or displacement is required when installing the IC on a PCB. If the IC is installed in the wrong way, it may break. Also, the threat of destruction from short-circuits exists if foreign matter invades between outputs or the output and GND of the power supply.

5) Operation under Strong Electromagnetic Field

Be careful of possible malfunctions under strong electromagnetic fields.

6) Common Impedance

When providing a power supply and GND wirings, show sufficient consideration for lowering common impedance and reducing ripple (i.e., using thick short wiring, cutting ripple down by LC, etc.) as much as you can.

7) Thermal Protection Circuit (TSD Circuit)

This IC contains a thermal protection circuit (TSD circuit). The TSD circuit serves to shut off the IC from thermal runaway and does not aim to protect or assure operation of the IC itself. Therefore, do not use the TSD circuit for continuous use or operation after the circuit has tripped.

8) Rush Current at the Time of Power Activation

Be careful of the power supply coupling capacity and the width of the power supply and GND pattern wiring and routing since rush current flows instantaneously at the time of power activation in the case of CMOS IC or ICs with multiple power supplies.

9) IC Terminal Input

This is a monolithic IC and has P+ isolation and a P substrate for element isolation between each element. P-N junctions are formed and various parasitic elements are configured using these P layers and N layers of the individual elements. For example, if a resistor and transistor are connected to a terminal as shown on Fig.30:

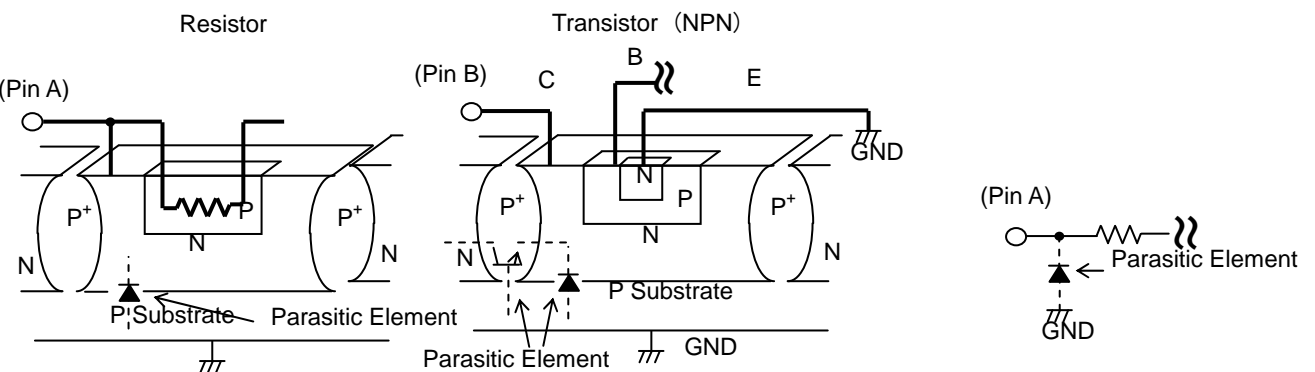

Fig.30 Example of simple structure of Bipolar IC

●Ordering part number

B	D
---	---

Part No.

8	3	0	1
---	---	---	---

Part No.

M	U	V
---	---	---

Package  
MUV: VQFN020V4040

E	2
---	---

Packaging and forming specification  
E2: Embossed tape and reel

VQFN020V4040

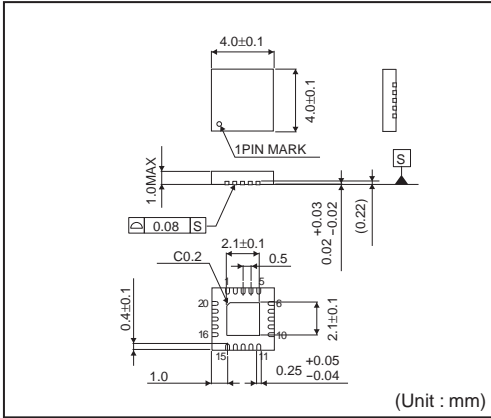

<Tape and Reel information>

Tape	Embossed carrier tape
Quantity	2500pcs
Direction of feed	E2 ( The direction is the 1pin of product is at the upper left when you hold reel on the left hand and you pull out the tape on the right hand )

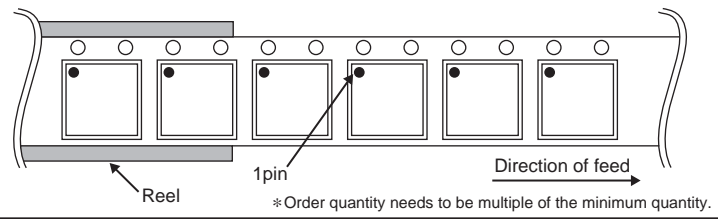

# Notice

## Precaution on using ROHM Products

- Our Products are designed and manufactured for application in ordinary electronic equipments (such as AV equipment, OA equipment, telecommunication equipment, home electronic appliances, amusement equipment, etc.). If you intend to use our Products in devices requiring extremely high reliability (such as medical equipment <sup>(Note 1)</sup>, transport equipment, traffic equipment, aircraft/spacecraft, nuclear power controllers, fuel controllers, car equipment including car accessories, safety devices, etc.) and whose malfunction or failure may cause loss of human life, bodily injury or serious damage to property ("Specific Applications"), please consult with the ROHM sales representative in advance. Unless otherwise agreed in writing by ROHM in advance, ROHM shall not be in any way responsible or liable for any damages, expenses or losses incurred by you or third parties arising from the use of any ROHM's Products for Specific Applications.

(Note1) Medical Equipment Classification of the Specific Applications

JAPAN	USA	EU	CHINA
CLASS III	CLASS III	CLASS II b	CLASS III
CLASS IV		CLASS III	

- ROHM designs and manufactures its Products subject to strict quality control system. However, semiconductor products can fail or malfunction at a certain rate. Please be sure to implement, at your own responsibilities, adequate safety measures including but not limited to fail-safe design against the physical injury, damage to any property, which a failure or malfunction of our Products may cause. The following are examples of safety measures:
  - Installation of protection circuits or other protective devices to improve system safety
  - Installation of redundant circuits to reduce the impact of single or multiple circuit failure
- Our Products are designed and manufactured for use under standard conditions and not under any special or extraordinary environments or conditions, as exemplified below. Accordingly, ROHM shall not be in any way responsible or liable for any damages, expenses or losses arising from the use of any ROHM's Products under any special or extraordinary environments or conditions. If you intend to use our Products under any special or extraordinary environments or conditions (as exemplified below), your independent verification and confirmation of product performance, reliability, etc. prior to use, must be necessary:
  - Use of our Products in any types of liquid, including water, oils, chemicals, and organic solvents
  - Use of our Products outdoors or in places where the Products are exposed to direct sunlight or dust
  - Use of our Products in places where the Products are exposed to sea wind or corrosive gases, including Cl<sub>2</sub>, H<sub>2</sub>S, NH<sub>3</sub>, SO<sub>2</sub>, and NO<sub>2</sub>
  - Use of our Products in places where the Products are exposed to static electricity or electromagnetic waves
  - Use of our Products in proximity to heat-producing components, plastic cords, or other flammable items
  - Sealing or coating our Products with resin or other coating materials
  - Use of our Products without cleaning residue of flux (even if you use no-clean type fluxes, cleaning residue of flux is recommended); or Washing our Products by using water or water-soluble cleaning agents for cleaning residue after soldering
  - Use of the Products in places subject to dew condensation
- The Products are not subject to radiation-proof design.
- Please verify and confirm characteristics of the final or mounted products in using the Products.
- In particular, if a transient load (a large amount of load applied in a short period of time, such as pulse. is applied, confirmation of performance characteristics after on-board mounting is strongly recommended. Avoid applying power exceeding normal rated power; exceeding the power rating under steady-state loading condition may negatively affect product performance and reliability.
- De-rate Power Dissipation (Pd) depending on Ambient temperature (Ta). When used in sealed area, confirm the actual ambient temperature.
- Confirm that operation temperature is within the specified range described in the product specification.
- ROHM shall not be in any way responsible or liable for failure induced under deviant condition from what is defined in this document.

## Precaution for Mounting / Circuit board design

- When a highly active halogenous (chlorine, bromine, etc.) flux is used, the residue of flux may negatively affect product performance and reliability.
- In principle, the reflow soldering method must be used; if flow soldering method is preferred, please consult with the ROHM representative in advance.

For details, please refer to ROHM Mounting specification

### Precautions Regarding Application Examples and External Circuits

1. If change is made to the constant of an external circuit, please allow a sufficient margin considering variations of the characteristics of the Products and external components, including transient characteristics, as well as static characteristics.
2. You agree that application notes, reference designs, and associated data and information contained in this document are presented only as guidance for Products use. Therefore, in case you use such information, you are solely responsible for it and you must exercise your own independent verification and judgment in the use of such information contained in this document. ROHM shall not be in any way responsible or liable for any damages, expenses or losses incurred by you or third parties arising from the use of such information.

### Precaution for Electrostatic

This Product is electrostatic sensitive product, which may be damaged due to electrostatic discharge. Please take proper caution in your manufacturing process and storage so that voltage exceeding the Products maximum rating will not be applied to Products. Please take special care under dry condition (e.g. Grounding of human body / equipment / solder iron, isolation from charged objects, setting of ionizer, friction prevention and temperature / humidity control).

### Precaution for Storage / Transportation

1. Product performance and soldered connections may deteriorate if the Products are stored in the places where:
  - [a] the Products are exposed to sea winds or corrosive gases, including Cl<sub>2</sub>, H<sub>2</sub>S, NH<sub>3</sub>, SO<sub>2</sub>, and NO<sub>2</sub>
  - [b] the temperature or humidity exceeds those recommended by ROHM
  - [c] the Products are exposed to direct sunshine or condensation
  - [d] the Products are exposed to high Electrostatic
2. Even under ROHM recommended storage condition, solderability of products out of recommended storage time period may be degraded. It is strongly recommended to confirm solderability before using Products of which storage time is exceeding the recommended storage time period.
3. Store / transport cartons in the correct direction, which is indicated on a carton with a symbol. Otherwise bent leads may occur due to excessive stress applied when dropping of a carton.
4. Use Products within the specified time after opening a humidity barrier bag. Baking is required before using Products of which storage time is exceeding the recommended storage time period.

### Precaution for Product Label

QR code printed on ROHM Products label is for ROHM's internal use only.

### Precaution for Disposition

When disposing Products please dispose them properly using an authorized industry waste company.

### Precaution for Foreign Exchange and Foreign Trade act

Since our Products might fall under controlled goods prescribed by the applicable foreign exchange and foreign trade act, please consult with ROHM representative in case of export.

### Precaution Regarding Intellectual Property Rights

1. All information and data including but not limited to application example contained in this document is for reference only. ROHM does not warrant that foregoing information or data will not infringe any intellectual property rights or any other rights of any third party regarding such information or data. ROHM shall not be in any way responsible or liable for infringement of any intellectual property rights or other damages arising from use of such information or data.:
2. No license, expressly or implied, is granted hereby under any intellectual property rights or other rights of ROHM or any third parties with respect to the information contained in this document.

### Other Precaution



1. This document may not be reprinted or reproduced, in whole or in part, without prior written consent of ROHM.
2. The Products may not be disassembled, converted, modified, reproduced or otherwise changed without prior written consent of ROHM.
3. In no event shall you use in any way whatsoever the Products and the related technical information contained in the Products or this document for any military purposes, including but not limited to, the development of mass-destruction weapons.
4. The proper names of companies or products described in this document are trademarks or registered trademarks of ROHM, its affiliated companies or third parties.

**General Precaution**

1. Before you use our Products, you are requested to carefully read this document and fully understand its contents. ROHM shall not be in any way responsible or liable for failure, malfunction or accident arising from the use of any ROHM's Products against warning, caution or note contained in this document.
2. All information contained in this document is current as of the issuing date and subject to change without any prior notice. Before purchasing or using ROHM's Products, please confirm the latest information with a ROHM sales representative.
3. The information contained in this document is provided on an "as is" basis and ROHM does not warrant that all information contained in this document is accurate and/or error-free. ROHM shall not be in any way responsible or liable for any damages, expenses or losses incurred by you or third parties resulting from inaccuracy or errors of or concerning such information.

## Looking for pricing, stock, or lifecycle information?

Click below to explore more details on WIN SOURCE:

-  [View BD8301MUV-E2 on WIN SOURCE](#)
-  [Rohm Semiconductor](#) Information

## Optimize Your Supply Chain with WIN SOURCE Solutions

-  Global Sourcing Solution
-  Obsolete Management
-  Cost Control Management
-  Shortage Management
-  Alternative Solution
-  Excess Inventory Management