



**THE DATASHEET OF
LTC2309IUF#PBF**



FEATURES

- **12-Bit Resolution**
- **Low Power: 1.5mW at 1ksps, 35µW Sleep Mode**
- **14ksps Throughput Rate**
- **Low Noise: SNR = 73.4dB**
- Guaranteed No Missing Codes
- Single 5V Supply
- 2-Wire I²C Compatible Serial Interface with Nine Addresses Plus One Global for Synchronization
- Fast Conversion Time: 1.3µs
- Internal Reference
- Internal 8-Channel Multiplexer
- Internal Conversion Clock
- Unipolar or Bipolar Input Ranges (Software Selectable)
- Guaranteed Operation from -40°C to 125°C (TSSOP Package)
- 24-Pin 4mm × 4mm QFN and 20-Pin TSSOP Packages

APPLICATIONS

- Industrial Process Control
- Motor Control
- Accelerometer Measurements
- Battery-Operated Instruments
- Isolated and/or Remote Data Acquisition
- Power Supply Monitoring

DESCRIPTION

The LTC[®]2309 is a low noise, low power, 8-channel, 12-bit successive approximation ADC with an I²C compatible serial interface. This ADC includes an internal reference and a fully differential sample-and-hold circuit to reduce common mode noise. The LTC2309 operates from an internal clock to achieve a fast 1.3µs conversion time.

The LTC2309 operates from a single 5V supply and draws just 300µA at a throughput rate of 1ksps. The ADC enters nap mode when not converting, reducing the power dissipation.

The LTC2309 is available in both a small 24-pin 4mm × 4mm QFN and a 20-pin TSSOP package. The internal 2.5V reference and 8-channel multiplexer further reduce PCB board space requirements.

The low power consumption and small size make the LTC2309 ideal for battery-operated and portable applications, while the 2-wire I²C compatible serial interface makes this ADC a good match for space-constrained systems.

LT, LTC, LTM, Linear Technology and the Linear logo are registered trademarks and Easy Drive is a trademark of Linear Technology Corporation. All other trademarks are the property of their respective owners.

BLOCK DIAGRAM

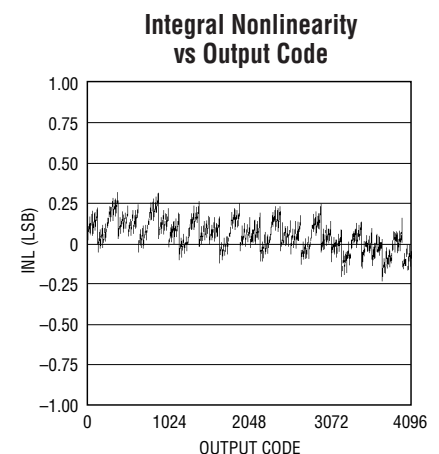
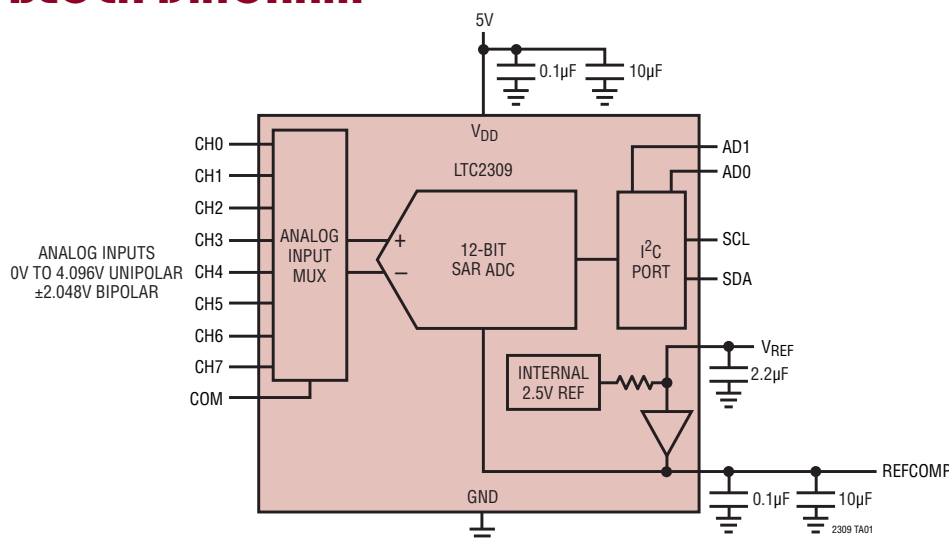

2309 G01
2309fd

LTC2309

ABSOLUTE MAXIMUM RATINGS (Notes 1, 2)

Supply Voltage		Power Dissipation	500mW
V_{DD}	-0.3V to 6V	Operating Temperature Range	
Analog Input Voltage (Note 3)		LTC2309C	0°C to 70°C
CH0-CH7, COM, V_{REF} ,		LTC2309I	-40°C to 85°C
REFCOMP	(GND - 0.3V) to (V_{DD} + 0.3V)	LTC2309H	-40°C to 125°C
Digital Input Voltage		Storage Temperature Range	-65°C to 150°C
(Note 3)	(GND - 0.3V) to (V_{DD} + 0.3V)	Lead Temperature (Soldering, 10 sec)	
Digital Output Voltage	(GND - 0.3V) to (V_{DD} + 0.3V)	TSSOP	300°C

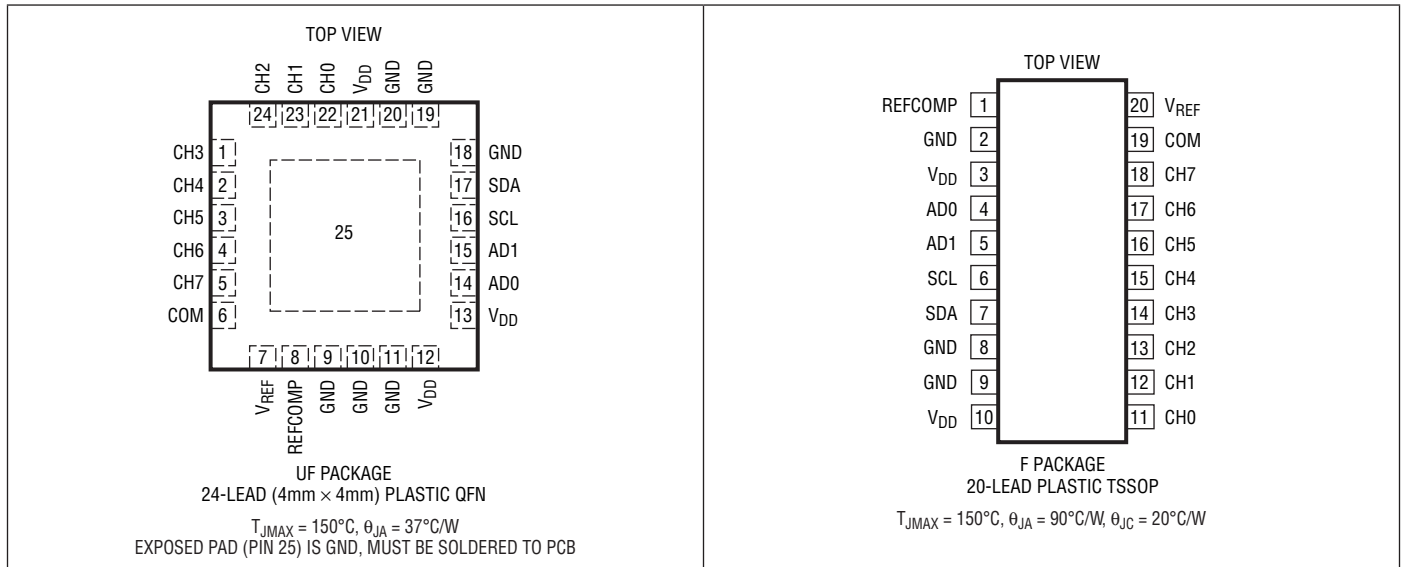
PIN CONFIGURATION



ORDER INFORMATION

LEAD FREE FINISH	TAPE AND REEL	PART MARKING*	PACKAGE DESCRIPTION	TEMPERATURE RANGE
LTC2309CUF#PBF	LTC2309CUF#TRPBF	2309	24-Lead (4mm × 4mm) Plastic QFN	0°C to 70°C
LTC2309IUF#PBF	LTC2309IUF#TRPBF	2309	24-Lead (4mm × 4mm) Plastic QFN	-40°C to 85°C
LTC2309CF#PBF	LTC2309CF#TRPBF	LTC2309F	20-Lead Plastic TSSOP	0°C to 70°C
LTC2309IF#PBF	LTC2309IF#TRPBF	LTC2309F	20-Lead Plastic TSSOP	-40°C to 85°C
LTC2309HF#PBF	LTC2309HF#TRPBF	LTC2309F	20-Lead Plastic TSSOP	-40°C to 125°C

Consult LTC Marketing for parts specified with wider operating temperature ranges. *The temperature grade is identified by a label on the shipping container. Consult LTC Marketing for information on non-standard lead based finish parts.

For more information on lead free part marking, go to: <http://www.linear.com/leadfree/>

For more information on tape and reel specifications, go to: <http://www.linear.com/tapeandreel/>

CONVERTER AND MULTIPLEXER CHARACTERISTICS

The ● denotes the specifications which apply over the full operating temperature range, otherwise specifications are at $T_A = 25^\circ\text{C}$. (Notes 4, 5)

PARAMETER	CONDITIONS	MIN	TYP	MAX	UNITS
Resolution (No Missing Codes)		●	12		Bits
Integral Linearity Error	(Note 6)	●	±0.45	±1	LSB
Differential Linearity Error		●	±0.35	±1	LSB
Bipolar Zero Error	(Note 7)	●	±1	±8	LSB
Bipolar Zero Error Drift			0.002		LSB/°C
Bipolar Zero Error Match			±0.1	±3	LSB
Unipolar Zero Error	(Note 7)	●	±0.4	±6	LSB
Unipolar Zero Error Drift			0.002		LSB/°C
Unipolar Zero Error Match			±0.2	±1	LSB
Bipolar Full-Scale Error	External Reference (Note 8) REFCOMP = 4.096V	●	±0.5	±10	LSB
		●	±0.4	±9	LSB
Bipolar Full-Scale Error Drift	External Reference		0.05		LSB/°C
Bipolar Full-Scale Error Match			±0.4	±3	LSB
Unipolar Full-Scale Error	QFN External Reference (Note 8) TSSOP External Reference (Note 8) REFCOMP = 4.096V	●	±0.4	±10	LSB
		●	±0.5	±12	LSB
		●	±0.3	±6	LSB
Unipolar Full-Scale Error Drift	External Reference		0.05		LSB/°C
Unipolar Full-Scale Error Match			±0.3	±2	LSB

ANALOG INPUT

The ● denotes the specifications which apply over the full operating temperature range, otherwise specifications are at $T_A = 25^\circ\text{C}$. (Note 4)

SYMBOL	PARAMETER	CONDITIONS	MIN	TYP	MAX	UNITS
V_{IN}^+	Absolute Input Range (CH0 to CH7)	(Note 9)	●	-0.05	REFCOMP	V
V_{IN}^-	Absolute Input Range (CH0 to CH7, COM)	Unipolar (Note 9)	●	-0.05	$0.25 \cdot \text{REFCOMP}$	V
		Bipolar (Note 9)	●	-0.05	$0.75 \cdot \text{REFCOMP}$	V
$V_{IN}^+ - V_{IN}^-$	Input Differential Voltage Range	$V_{IN} = V_{IN}^+ - V_{IN}^-$ (Unipolar) $V_{IN} = V_{IN}^+ - V_{IN}^-$ (Bipolar)	●	0 to REFCOMP		V
			●	$\pm \text{REFCOMP}/2$		V
I_{IN}	Analog Input Leakage Current		●		±1	μA
C_{IN}	Analog Input Capacitance	Sample Mode		55		pF
		Hold Mode		5		pF
CMRR	Input Common Mode Rejection Ratio			70		dB

DYNAMIC ACCURACY

The ● denotes the specifications which apply over the full operating temperature range, otherwise specifications are at $T_A = 25^\circ\text{C}$. $A_{IN} = -1\text{dBFS}$. (Notes 4, 10)

SYMBOL	PARAMETER	CONDITIONS	MIN	TYP	MAX	UNITS
SINAD	Signal-to-(Noise + Distortion) Ratio	$f_{IN} = 1\text{kHz}$	●	71	73.3	dB
SNR	Signal-to-Noise Ratio	$f_{IN} = 1\text{kHz}$	●	71	73.4	dB
THD	Total Harmonic Distortion	$f_{IN} = 1\text{kHz}$, First 5 Harmonics	●		-88	dB
SFDR	Spurious Free Dynamic Range	$f_{IN} = 1\text{kHz}$	●	79	90	dB
	Channel-to-Channel Isolation	$f_{IN} = 1\text{kHz}$			-109	dB
	Full Linear Bandwidth	(Note 11)		700		kHz
	-3dB Input Linear Bandwidth			25		MHz
	Aperture Delay			13		ns
	Transient Response	Full-Scale Step		240		ns

INTERNAL REFERENCE CHARACTERISTICS

The ● denotes the specifications which apply over the full operating temperature range, otherwise specifications are at $T_A = 25^\circ\text{C}$. (Note 4)

PARAMETER	CONDITIONS	MIN	TYP	MAX	UNITS
V_{REF} Output Voltage	$I_{OUT} = 0$ (QFN)	● 2.47	2.50	2.53	V
	$I_{OUT} = 0$ (TSSOP)	● 2.46	2.50	2.54	V
V_{REF} Output Tempco	$I_{OUT} = 0$		±25		ppm/°C
V_{REF} Output Impedance	$-0.1\text{mA} \leq I_{OUT} \leq 0.1\text{mA}$		8		k Ω
$V_{REFCOMP}$ Output Voltage	$I_{OUT} = 0$		4.096		V
V_{REF} Line Regulation	$V_{DD} = 4.75\text{V}$ to 5.25V		0.8		mV/V

I²C INPUTS AND DIGITAL OUTPUTS

The ● denotes the specifications which apply over the full operating temperature range, otherwise specifications are at $T_A = 25^\circ\text{C}$. (Note 4)

SYMBOL	PARAMETER	CONDITIONS	MIN	TYP	MAX	UNITS
V_{IH}	High Level Input Voltage		● 2.85			V
V_{IL}	Low Level Input Voltage				1.5	V
V_{IHA}	High Level Input Voltage for Address Pins A1, A0		● 4.75			V
V_{ILA}	Low Level Input Voltage for Address Pins A1, A0				0.25	V
R_{INH}	Resistance from A1, A0, to V_{DD} to Set Chip Address Bit to 1				10	k Ω
R_{INL}	Resistance from A1, A0 to GND to Set Chip Address Bit to 0				10	k Ω
R_{INF}	Resistance from A1, A0 to GND or V_{DD} to Set Chip Address Bit to Float		● 2			M Ω
I_I	Digital Input Current	$V_{IN} = V_{DD}$	● -10		10	μA
V_{HYS}	Hysteresis of Schmitt Trigger Inputs	(Note 9)	● 0.25			V
V_{OL}	Low Level Output Voltage (SDA)	$I = 3\text{mA}$			0.4	V
t_{OF}	Output Fall Time V_H to $V_{IL(MAX)}$	(Note 12)	● $20 + 0.1C_B$		250	ns
t_{SP}	Input Spike Suppression				50	ns
C_{CAX}	External Capacitance Load On-Chip Address Pins (A1, A0) for Valid Float				10	pF

POWER REQUIREMENTS

The ● denotes the specifications which apply over the full operating temperature range, otherwise specifications are at $T_A = 25^\circ\text{C}$. (Note 4)

SYMBOL	PARAMETER	CONDITIONS	MIN	TYP	MAX	UNITS
V_{DD}	Supply Voltage		● 4.75	5	5.25	V
I_{DD}	Supply Current	14ksps Sample Rate	●	2.3	3	mA
	Nap Mode	SLP Bit = 0, Conversion Done	●	210	350	μA
	Sleep Mode	SLP Bit = 1, Conversion Done	●	7	15	μA
P_D	Power Dissipation	14ksps Sample Rate	●	11.5	15	mW
	Nap Mode	SLP Bit = 0, Conversion Done	●	1.05	1.75	mW
	Sleep Mode	SLP Bit = 1, Conversion Done	●	35	75	μW

I²C TIMING CHARACTERISTICS

The ● denotes the specifications which apply over the full operating temperature range, otherwise specifications are at T_A = 25°C. (Note 4)

SYMBOL	PARAMETER	CONDITIONS	MIN	TYP	MAX	UNITS
f _{SCL}	SCL Clock Frequency		●		400	kHz
t _{HD(SDA)}	Hold Time (Repeated) START Condition		●	0.6		μs
t _{LOW}	LOW Period of the SCL Pin		●	1.3		μs
t _{HIGH}	HIGH Period of the SCL Pin		●	0.6		μs
t _{SU(STA)}	Set-Up Time for a Repeated START Condition		●	0.6		μs
t _{HD(DAT)}	Data Hold Time		●	0	0.9	μs
t _{SU(DAT)}	Data Set-Up Time		●	100		ns
t _r	Rise Time for SDA/SCL Signals	(Note 12)	●	20 + 0.1C _B	300	ns
t _f	Fall Time for SDA/SCL Signals	(Note 12)	●	20 + 0.1C _B	300	ns
t _{SU(STO)}	Set-Up Time for STOP Condition		●	0.6		μs
t _{BUF}	Bus Free Time Between a STOP and START Condition		●	1.3		μs

ADC TIMING CHARACTERISTICS

The ● denotes the specifications which apply over the full operating temperature range, otherwise specifications are at T_A = 25°C. (Note 4)

SYMBOL	PARAMETER	CONDITIONS	MIN	TYP	MAX	UNITS
f _{SMPL}	Throughput Rate (Successive Reads)		●		14	ksps
t _{CONV}	Conversion Time	(Note 9)	●	1.3	1.8	μs
t _{ACQ}	Acquisition Time	(Note 9)	●		240	ns
t _{REFWAKE}	REFCOMP Wake-Up Time (Note 13)	C _{REFCOMP} = 10μF, C _{REF} = 2.2μF		200		ms

Note 1: Stresses beyond those listed under Absolute Maximum Ratings may cause permanent damage to the device. Exposure to any Absolute Maximum Rating condition for extended periods may affect device reliability and lifetime.

Note 2: All voltage values are with respect to ground.

Note 3: When these pin voltages are taken below ground or above V_{DD}, they will be clamped by internal diodes. These products can handle input currents greater than 100mA below ground or above V_{DD} without latchup.

Note 4: V_{DD} = 5V, f_{SMPL} = 14ksps internal reference unless otherwise noted.

Note 5: Linearity, offset and full-scale specifications apply for a single-ended analog input with respect to COM.

Note 6: Integral nonlinearity is defined as the deviation of a code from a straight line passing through the actual endpoints of the transfer curve. The deviation is measured from the center of the quantization band.

Note 7: Bipolar zero error is the offset voltage measured from -0.5LSB when the output code flickers between 0000 0000 0000 and 1111 1111

1111. Unipolar zero error is the offset voltage measured from +0.5LSB when the output code flickers between 0000 0000 0000 and 0000 0000 0001.

Note 8: Full-scale bipolar error is the worst-case of -FS or +FS untrimmed deviation from ideal first and last code transitions and includes the effect of offset error. Unipolar full-scale error is the deviation of the last code transition from ideal and includes the effect of offset error.

Note 9: Guaranteed by design, not subject to test.

Note 10: All specifications in dB are referred to a full-scale ±2.048V input with a 2.5V reference voltage.

Note 11: Full linear bandwidth is defined as the full-scale input frequency at which the SINAD degrades to 60dB or 10 bits of accuracy.

Note 12: C_B = capacitance of one bus line in pF (10pF ≤ C_B ≤ 400pF).

Note 13: REFCOMP wake-up time is the time required for the REFCOMP pin to settle within 0.5LSB at 12-bit resolution of its final value after waking up from SLEEP mode.

TYPICAL PERFORMANCE CHARACTERISTICS

$T_A = 25^\circ\text{C}$, $V_{DD} = 5\text{V}$, $f_{\text{SAMPL}} = 14\text{kps}$, unless otherwise noted.

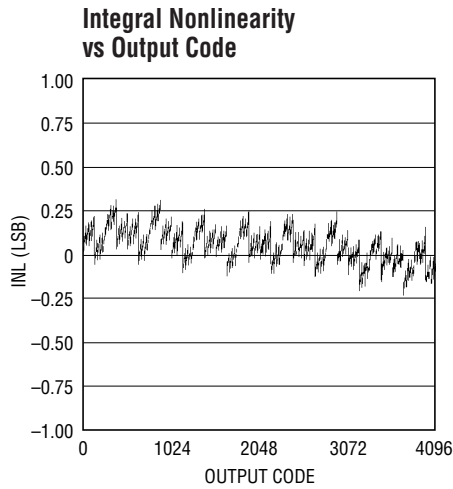

2309 G01

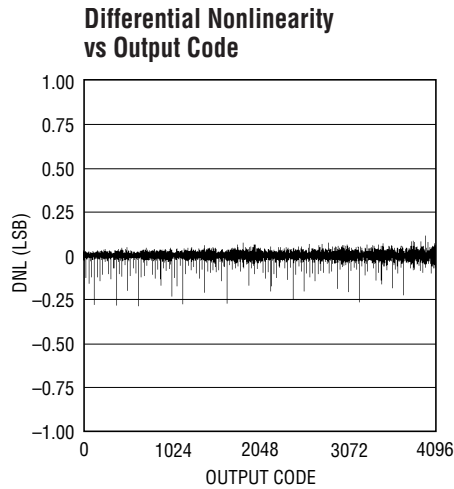

2309 G02

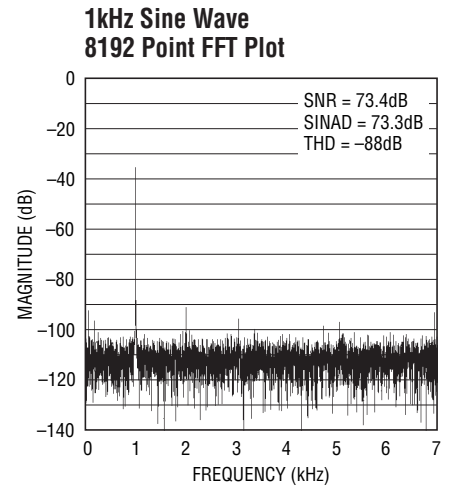

2309 G03

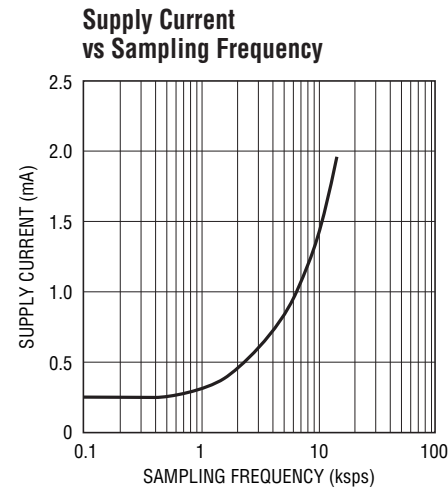

2309 G04

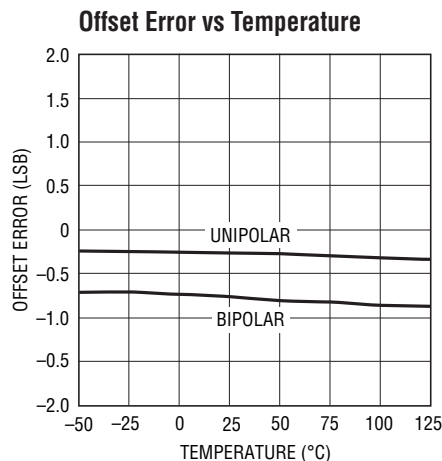

2309 G05

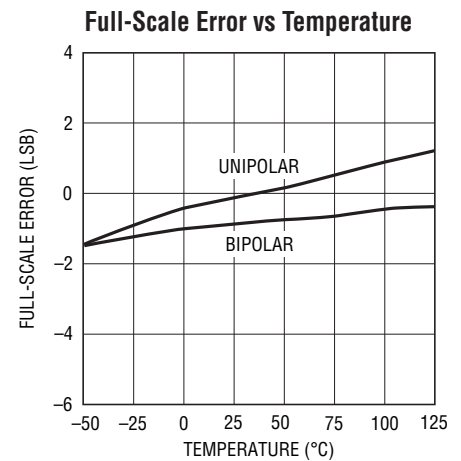

2309 G06

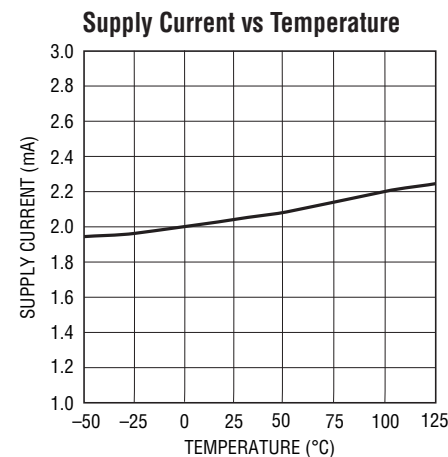

2309 G07

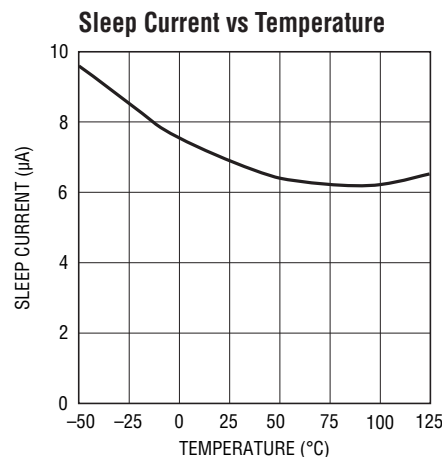

2309 G08

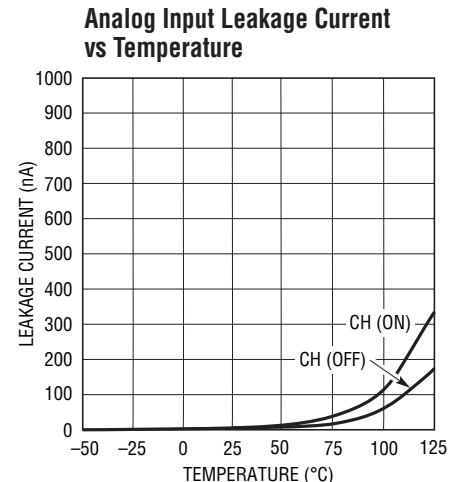

2309 G09
2309fd

PIN FUNCTIONS (QFN)

CH3-CH7 (Pins 1-5): Channel 3 to Channel 7 Analog Inputs. CH3-CH7 can be configured as single-ended or differential input channels. See the Analog Input Multiplexer section.

COM (Pin 6): Common Input. This is the reference point for all single-ended inputs. It must be free of noise and should be connected to ground for unipolar conversions and midway between GND and REFCOMP for bipolar conversions.

V_{REF} (Pin 7): 2.5V Reference Output. Bypass to GND with a minimum 2.2 μ F ceramic capacitor. The internal reference may be overdriven by an external 2.5V reference at this pin.

REFCOMP (Pin 8): Reference Buffer Output. Bypass to GND with 10 μ F and 0.1 μ F ceramic capacitors in parallel. Nominal output voltage is 4.096V. The internal reference buffer driving this pin is disabled by grounding V_{REF}, allowing REFCOMP to be overdriven by an external source.

GND (Pins 9-11, 18-20): Ground. All GND pins must be connected to a solid ground plane.

V_{DD} (Pins 12, 13, 21): 5V Supply. The range of V_{DD} is 4.75V to 5.25V. Bypass V_{DD} to GND with a 10 μ F ceramic capacitor in parallel with three 0.1 μ F ceramic capacitors, one located as close as possible to each pin.

AD0 (Pin 14): Chip Address Control Pin. This pin is configured as a three-state (LOW, HIGH, floating) address control bit for the device I²C address. See Table 2 for address selection.

AD1 (Pin 15): Chip Address Control Pin. This pin is configured as a three-state (LOW, HIGH, floating) address control bit for the device I²C address. See Table 2 for address selection.

SCL (Pin 16): Serial Clock Pin of the I²C Interface. The LTC2309 can only act as a slave and the SCL pin only accepts an external serial clock. Data is shifted into the SDA pin on the rising edges of the SCL clock and output through the SDA pin on the falling edges of the SCL clock.

SDA (Pin 17): Bidirectional Serial Data Line of the I²C Interface. In transmitter mode (read), the conversion result is output at the SDA pin, while in receiver mode (write), the D_{IN} word is input at the SDA pin to configure the ADC. The pin is high impedance during the data input mode and is an open-drain output (requires an appropriate pull-up device to V_{DD}) during the data output mode.

CH0-CH2 (Pins 22-24): Channel 0 to Channel 2 Analog Inputs. CH0-CH2 can be configured as single-ended or differential input channels. See the Analog Input Multiplexer section.

Exposed Pad (Pin 25): Ground. Must be soldered directly to ground plane.

PIN FUNCTIONS (TSSOP)

REFCOMP (Pin 1): Reference Buffer Output. Bypass to GND with 10 μ F and 0.1 μ F ceramic capacitors in parallel. Nominal output voltage is 4.096V. The internal reference buffer driving this pin is disabled by grounding V_{REF} , allowing REFCOMP to be overdriven by an external source.

GND (Pins 2, 8, 9): Ground. All GND pins must be connected to a solid ground plane.

V_{DD} (Pins 3, 10): 5V Supply. The range of V_{DD} is 4.75V to 5.25V. Bypass V_{DD} to GND with a 10 μ F ceramic capacitor in parallel with two 0.1 μ F ceramic capacitors, one located as close as possible to each pin.

AD0 (Pin 4): Chip Address Control Pin. This pin is configured as a three-state (LOW, HIGH, floating) address control bit for the device I²C address. See Table 2 for address selection.

AD1 (Pin 5): Chip Address Control Pin. This pin is configured as a three-state (LOW, HIGH, floating) address control bit for the device I²C address. See Table 2 for address selection.

SCL (Pin 6): Serial Clock Pin of the I²C Interface. The LTC2309 can only act as a slave and the SCL pin only accepts an external serial clock. Data is shifted into the SDA pin on the rising edges of the SCL clock and output through the SDA pin on the falling edges of the SCL clock.

SDA (Pin 7): Bidirectional Serial Data Line of the I²C Interface. In transmitter mode (read), the conversion result is output at the SDA pin, while in receiver mode (write), the D_{IN} word is input at the SDA pin to configure the ADC. The pin is high impedance during the data input mode and is an open-drain output (requires an appropriate pull-up device to V_{DD}) during the data output mode.

CH0-CH7 (Pins 11-18): Channel 0 to Channel 7 Analog Inputs. CH0-CH7 can be configured as single-ended or differential input channels. See the Analog Input Multiplexer section.

COM (Pin 19): Common Input. This is the reference point for all single-ended inputs. It must be free of noise and should be connected to ground for unipolar conversions and midway between GND and REFCOMP for bipolar conversions.

V_{REF} (Pin 20): 2.5V Reference Output. Bypass to GND with a minimum 2.2 μ F ceramic capacitor. The internal reference may be overdriven by an external 2.5V reference at this pin.

FUNCTIONAL BLOCK DIAGRAM

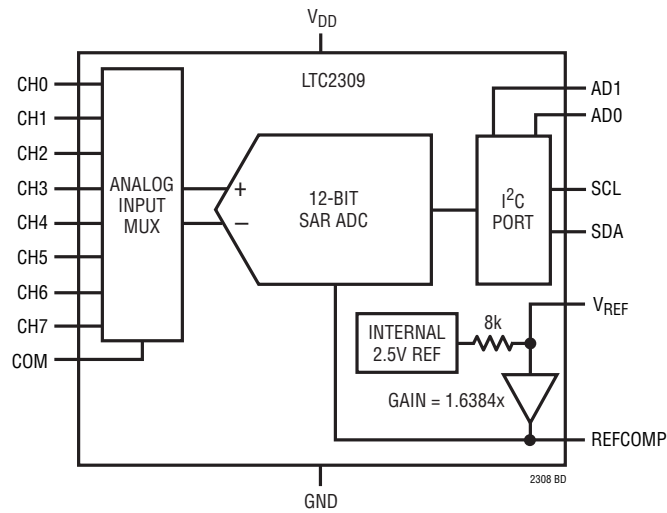

TIMING DIAGRAM

Definition of Timing for Fast/Standard Mode Devices on the I²C Bus

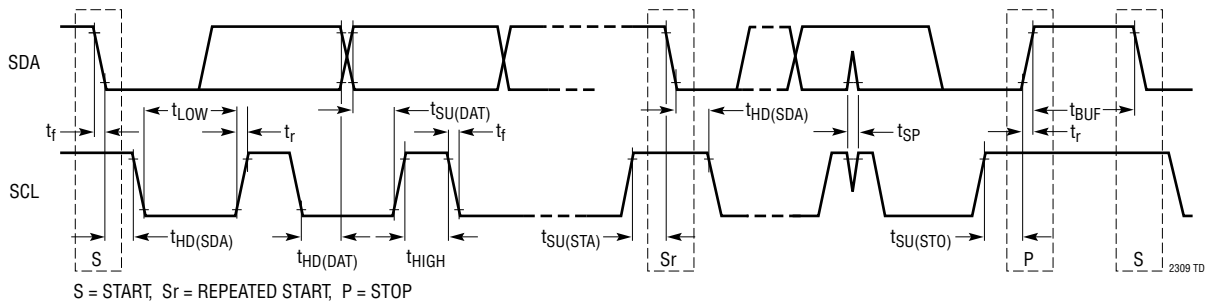

APPLICATIONS INFORMATION

Overview

The LTC2309 is a low noise, 8-channel, 12-bit successive approximation register (SAR) A/D converter with an I²C compatible serial interface. The LTC2309 includes a precision internal reference and a configurable 8-channel analog input multiplexer (MUX). The ADC may be configured to accept single-ended or differential signals and can operate in either unipolar or bipolar mode. A sleep mode option is also provided to further reduce power during inactive periods.

The LTC2309 communicates through a 2-wire I²C compatible serial interface. Conversions are initiated by signaling a STOP condition after the part has been successfully addressed for a read/write operation. The device will not acknowledge (NACK) an external request until the conversion is finished. After a conversion is finished, the device is ready to accept a read/write request. Once the LTC2309 is addressed for a read operation, the device begins outputting the conversion result under the control of the serial clock (SCL). There is no latency in the conversion result. There are 12 bits of output data followed by 4 trailing zeros. Data is updated on the falling edges of SCL, allowing the user to reliably latch data on the rising edge of SCL. A write operation may follow the read operation by using a repeat START or a STOP condition may be given to start a new conversion. By selecting a write operation, the ADC can be programmed with a 6-bit D_{IN} word. The D_{IN} word configures the MUX and programs various modes of operation of the ADC.

During a conversion, the internal 12-bit capacitive charge redistribution DAC output is sequenced through a successive approximation algorithm by the SAR starting from the most significant bit (MSB) to the least significant bit (LSB). The sampled input is successively compared with binary weighted charges supplied by the capacitive DAC using a differential comparator. At the end of a conversion, the DAC output balances the analog input. The SAR contents (a 12-bit data word) that represent the sampled analog input are loaded into 12 output latches that allow the data to be shifted out via the I²C interface.

Programming the LTC2309

The various modes of operation of the LTC2309 are programmed by a 6-bit D_{IN} word. The SDI input data bits are loaded on the rising edge of SCL during a write operation, with the S/D bit loaded on the first rising edge and the SLP bit on the sixth rising edge (see Figure 8b in the I²C Interface section). The input data word is defined as follows:

S/D	O/S	S1	S0	UNI	SLP
-----	-----	----	----	-----	-----

S/D = SINGLE-ENDED/DIFFERENTIAL BIT

O/S = ODD/SIGN BIT

S1 = CHANNEL SELECT BIT 1

S0 = CHANNEL SELECT BIT 0

UNI = UNIPOLAR/BIPOLAR BIT

SLP = SLEEP MODE BIT

Analog Input Multiplexer

The analog input MUX is programmed by the S/D, O/S, S1 and S0 bits of the D_{IN} word. Table 1 lists the MUX configurations for all combinations of the configuration bits. Figure 1a shows several possible MUX configurations and Figure 1b shows how the MUX can be reconfigured from one conversion to the next.

Driving the Analog Inputs

The analog inputs of the LTC2309 are easy to drive. Each of the analog inputs can be used as a single-ended input relative to the COM pin (CH0-COM, CH1-COM, etc.) or in differential input pairs (CH0 and CH1, CH2 and CH3, CH4 and CH5, CH6 and CH7). Figure 2 shows how to drive COM for single-ended inputs in unipolar and bipolar modes. Regardless of the MUX configuration, the “+” and “-” inputs are sampled at the same instant. Any unwanted signal that is common to both inputs will be reduced by the common mode rejection of the sample-and-hold circuit. The inputs draw only one small current spike while charging the sample-and-hold capacitors during the acquire mode. In conversion

APPLICATIONS INFORMATION

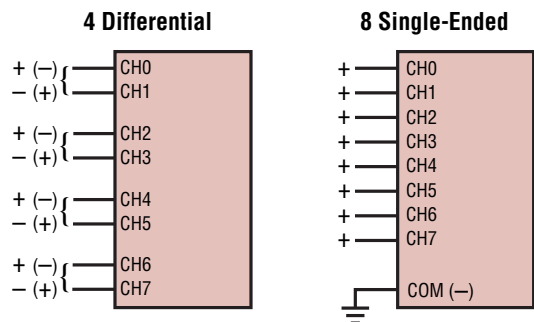

Combinations of Differential and Single-Ended

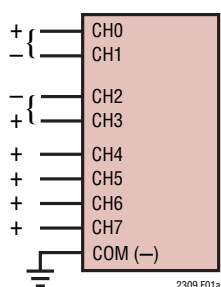

Figure 1a. Example of MUX Configurations

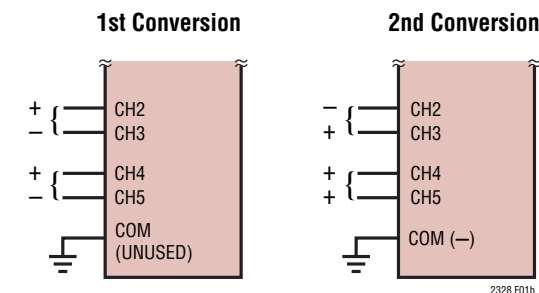

Figure 1b. Changing the MUX Assignments "On the Fly"

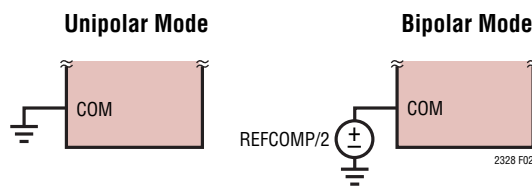

Figure 2. Driving COM in Unipolar and Bipolar Modes

Table 1. Channel Configuration

S/D	O/S	S1	S0	0	1	2	3	4	5	6	7	COM
0	0	0	0	+	-							
0	0	0	1			+	-					
0	0	1	0					+	-			
0	0	1	1							+	-	
0	1	0	0	-	+							
0	1	0	1			-	+					
0	1	1	0					-	+			
0	1	1	1							-	+	
1	0	0	0	+								-
1	0	0	1			+						-
1	0	1	0					+				-
1	0	1	1							+		-
1	1	0	0		+							-
1	1	0	1				+					-
1	1	1	0						+			-
1	1	1	1								+	-

mode, the analog inputs draw only a small leakage current. If the source impedance of the driving circuit is low, the ADC inputs can be driven directly. Otherwise, more acquisition time should be allowed for a source with higher impedance.

Input Filtering

The noise and distortion of the input amplifier and other circuitry must be considered since they will add to the ADC noise and distortion. Therefore, noisy input circuitry should be filtered prior to the analog inputs to minimize noise. A simple 1-pole RC filter is sufficient for many applications.

The analog inputs of the LTC2309 can be modeled as a 55pF capacitor (C_{IN}) in series with a 100Ω resistor (R_{ON}), as shown in Figure 3a. C_{IN} gets switched to the selected input once during each conversion. Large filter RC time constants will slow the settling of the inputs. It is important that the overall RC time constants be short enough to allow the analog inputs to completely settle to 12-bit resolution within the acquisition time (t_{ACQ}) if DC accuracy is important.

APPLICATIONS INFORMATION

When using a filter with a large C_{FILTER} value (e.g. $1\mu\text{F}$), the inputs do not completely settle and the capacitive input switching currents are averaged into a net DC current (I_{DC}). In this case, the analog input can be modeled by an equivalent resistance ($R_{\text{EQ}} = 1/(f_{\text{SMPL}} \cdot C_{\text{IN}})$) in series with an ideal voltage source ($V_{\text{REFCOMP}}/2$), as shown in Figure 3b. The magnitude of the DC current is then approximately $I_{\text{DC}} = (V_{\text{IN}} - V_{\text{REFCOMP}}/2)/R_{\text{EQ}}$, which is roughly proportional to V_{IN} . To prevent large DC drops across the resistor R_{FILTER} , a filter with a small resistor and large capacitor should be chosen. When running at the maximum throughput rate of 14ksps, the input current equals $1.5\mu\text{A}$ at $V_{\text{IN}} = 4.096\text{V}$, which amounts to a full-scale error of 0.5LSB when using a filter resistor (R_{FILTER}) of 333Ω . Applications requiring lower sample rates can tolerate a larger filter resistor for the same amount of full-scale error.

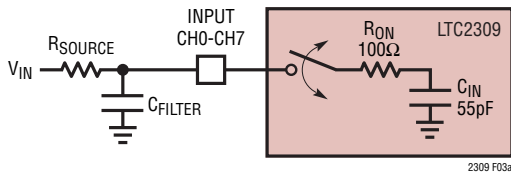

Figure 3a. Analog Input Equivalent Circuit

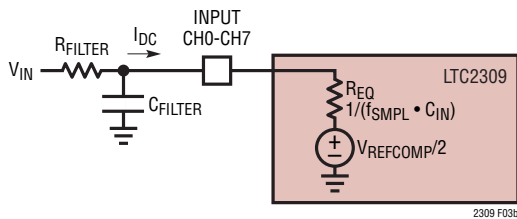

Figure 3b. Analog Input Equivalent Circuit for Large Filter Capacitances

Figures 4a and 4b show examples of input filtering for single-ended and differential inputs. For the single-ended case in Figure 4a, a 50Ω source resistor and a 2000pF capacitor to ground on the input will limit the input bandwidth to 1.6MHz . High quality capacitors and resistors should be used in the RC filter since these components can add distortion. NPO and silver mica type dielectric capacitors have excellent linearity. Carbon surface mount resistors can generate distortion from

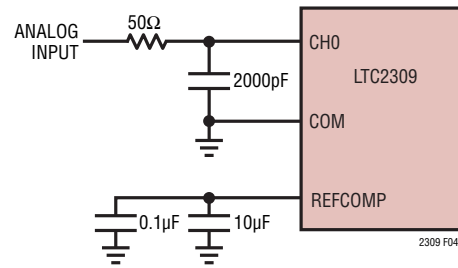

Figure 4a. Optional RC Input Filtering for Single-Ended Input

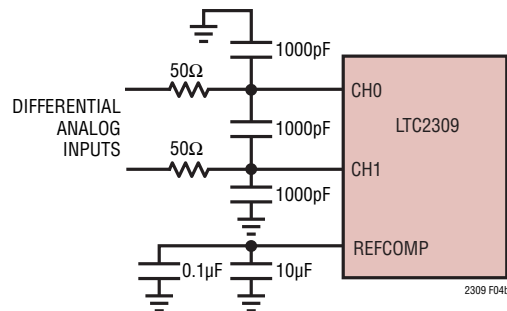

Figure 4b. Optional RC Input Filtering for Differential Inputs

self heating and from damage that may occur during soldering. Metal film surface mount resistors are much less susceptible to both problems.

Dynamic Performance

Fast Fourier Transform (FFT) test techniques are used to test the ADC's frequency response, distortion and noise at the rated throughput. By applying a low distortion sine wave and analyzing the digital output using an FFT algorithm, the ADC's spectral content can be examined for frequencies outside the fundamental.

Signal-to-Noise and Distortion Ratio (SINAD)

The signal-to-noise and distortion ratio (SINAD) is the ratio between the RMS amplitude of the fundamental input frequency to the RMS amplitude of all other frequency components at the A/D output. The output is band-limited to frequencies from above DC and below half the sampling frequency. Figure 5 shows a typical SINAD of 73.3dB with a 14kHz sampling rate and a 1kHz input. An SNR of 73.4dB can be achieved with the LTC2309.

APPLICATIONS INFORMATION

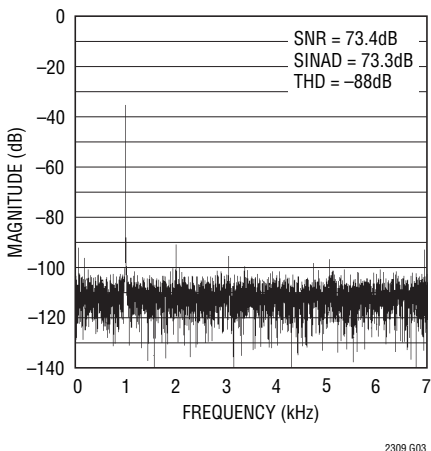

Figure 5. 1kHz Sine Wave 8192 Point FFT Plot

Total Harmonic Distortion (THD)

Total harmonic distortion (THD) is the ratio of the RMS sum of all harmonics of the input signal to the fundamental itself. The out-of-band harmonics alias into the frequency band between DC and half the sampling frequency ($f_{\text{SAMPL}}/2$). THD is expressed as:

$$\text{THD} = 20 \log \frac{\sqrt{V_2^2 + V_3^2 + V_4^2 \dots + V_N^2}}{V_1}$$

where V_1 is the RMS amplitude of the fundamental frequency and V_2 through V_N are the amplitudes of the second through Nth harmonics.

Internal Reference

The LTC2309 has an on-chip, temperature compensated bandgap reference that is factory trimmed to 2.5V (Refer to Figure 6a). It is internally connected to a reference amplifier and is available at V_{REF} . V_{REF} should be bypassed to GND with a $2.2\mu\text{F}$ ceramic capacitor to minimize noise. An $8\text{k}\Omega$ resistor is in series with the output so that it can be easily overdriven by an external reference if more accuracy and/or lower drift are required, as shown in Figure 6b. The reference amplifier gains the V_{REF} voltage by 1.638 to 4.096V at REFCOMP. To compensate the reference amplifier, bypass REFCOMP with a $10\mu\text{F}$ ceramic capacitor in parallel with a $0.1\mu\text{F}$ ceramic capacitor for best noise performance. The

internal reference buffer can also be overdriven from 1V to V_{DD} , as shown in Figure 6c. To do so, V_{REF} must be grounded to disable the reference buffer.

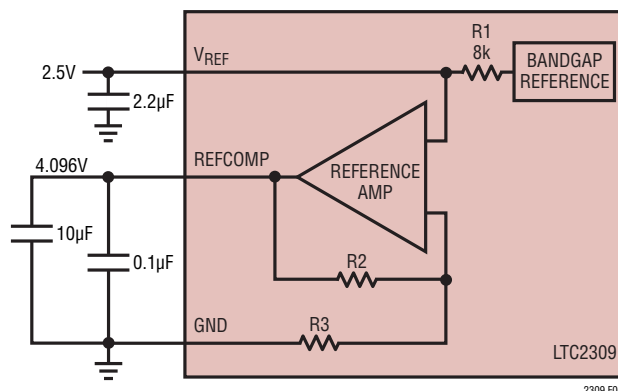

Figure 6a. LTC2309 Reference Circuit

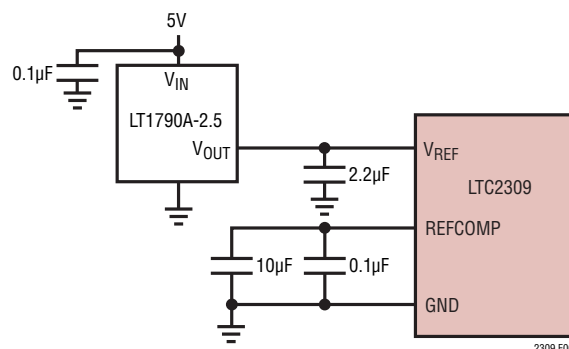

Figure 6b. Using the LT[®]1790A-2.5 as an External Reference

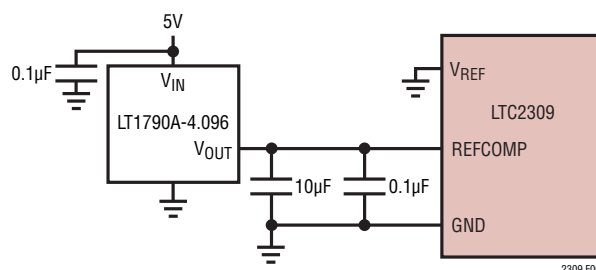

Figure 6c. Overdriving REFCOMP Using the LT1790A-4.096

APPLICATIONS INFORMATION

Internal Conversion Clock

The internal conversion clock is factory trimmed to achieve a typical conversion time (t_{CONV}) of 1.3 μ s and a maximum conversion time of 1.8 μ s over the full operating temperature range.

I²C Interface

The LTC2309 communicates through an I²C interface. The I²C interface is a 2-wire open-drain interface supporting multiple devices and multiple masters on a single bus. The connected devices can only pull the serial data line (SDA) LOW and can never drive it HIGH. SDA is required to be externally connected to the supply through a pull-up resistor. When the data line is not being driven LOW, it is HIGH. Data on the I²C bus can be transferred at rates up to 100kbits/s in the standard mode and up to 400kbits/s in the fast mode. The V_{DD} power should not be removed from the LTC2309 when the I²C bus is active to avoid loading the I²C bus lines through the internal ESD protection diodes.

Each device on the I²C bus is recognized by a unique address stored in the device and can only operate either as a transmitter or receiver, depending on the function of the device. A device can also be considered as a master or a slave when performing data transfers. A master is the device which initiates a data transfer on the bus and generates the clock signals to permit the transfer. Devices addressed by the master are considered slaves.

The LTC2309 can only be addressed as a slave (see Table 2). Once addressed, it can receive configuration bits (D_{IN} word) or transmit the last conversion result. The serial clock line (SCL) is always an input to the LTC2309 and the serial data line (SDA) is bidirectional. The device supports the standard mode and the fast mode for data transfer speeds up to 400kbits/s (see the Timing Diagram section for definition of the I²C timing).

The START and STOP Conditions

Referring to Figure 7, a START (S) condition is generated by transitioning SDA from HIGH to LOW while SCL is HIGH. The bus is considered to be busy after the START condition. When the data transfer is finished, a STOP (P) condition is generated by transitioning SDA from LOW to HIGH while SCL is HIGH. The bus is free after a STOP condition is generated. START and STOP conditions are always generated by the master.

When the bus is in use, it stays busy if a repeated START (Sr) is generated instead of a STOP condition. The repeated START timing is functionally identical to the START and is used for writing and reading from the device before the initiation of a new conversion.

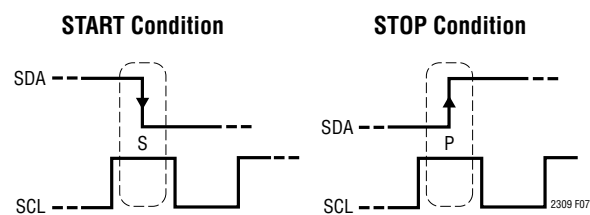

Figure 7. Timing Diagrams of START and STOP Conditions

Data Transferring

After the START condition, the I²C bus is busy and data transfer can begin between the master and the addressed slave. Data is transferred over the bus in groups of nine bits, one byte followed by one acknowledge (ACK) bit. The master releases the SDA line during the ninth SCL clock cycle. The slave device can issue an ACK by pulling SDA LOW or issue a Not Acknowledge (NACK) by leaving the SDA line high impedance (the external pull-up resistor will hold the line high). Change of data only occurs while the SCL line is LOW.

Data Format

After a START condition, the master sends a 7-bit address followed by a read/write (R/\bar{W}) bit. The R/\bar{W} bit is 1 for a read request and 0 for a write request. If the 7-bit address matches one of the LTC2309's 9 pin-selectable addresses, the ADC is selected. When

2309fd

APPLICATIONS INFORMATION

the ADC is addressed during a conversion, it will not acknowledge R/W requests and will issue a NACK by leaving the SDA line HIGH. If the conversion is complete, the LTC2309 issues an ACK by pulling the SDA line LOW. The LTC2309 has two registers. The 12-bit wide output register contains the last conversion result. The 6-bit wide input register configures the input MUX and the operating mode of the ADC.

Output Data Format

The output register contains the last conversion result. After each conversion is completed, the device automatically enters either nap or sleep mode depending on the setting of the SLP bit (see Nap Mode and Sleep Mode sections). When the LTC2309 is addressed for

a read operation, it acknowledges by pulling SDA LOW and acts as a transmitter. The master/receiver can read up to two bytes from the LTC2309. After a complete read operation of 2 bytes, a STOP condition is needed to initiate a new conversion. The device will NACK subsequent read operations while a conversion is being performed.

The data output stream is 16 bits long and is shifted out on the falling edges of SCL (see Figure 8a). The first bit is the MSB and the 12th bit is the LSB of the conversion result. The remaining four bits are zero. Figures 14 and 15 are the transfer characteristics for the bipolar and unipolar modes. Data is output on the SDA line in 2's complement format for bipolar readings or in straight binary for unipolar readings.

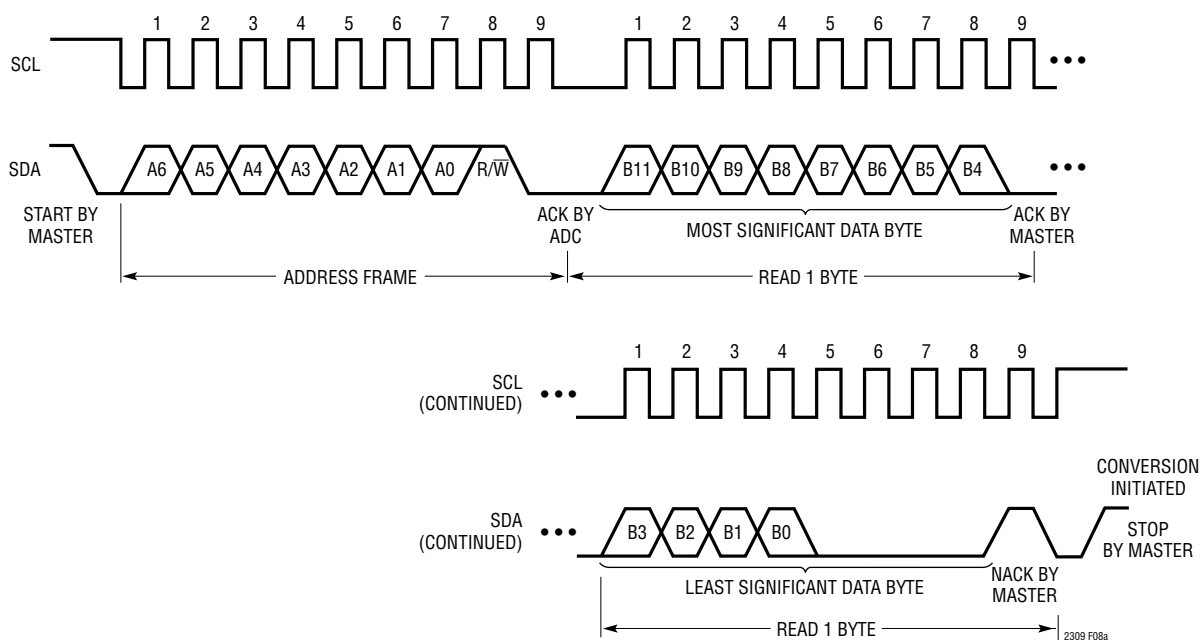

Figure 8a. Timing Diagram for Reading from the LTC2309

APPLICATIONS INFORMATION

Input Data Format

When the LTC2309 is addressed for a write operation, it acknowledges by pulling SDA LOW during the LOW period before the 9th cycle and acts as a receiver. The master/transmitter can then send 1 byte to program the device. The input byte consists of the 6-bit D_{IN} word followed by two bits that are ignored by the ADC and are considered don't cares (X) (see Figure 8b). The input bits are latched on the rising edge of SCL during the write operation.

After power-up, the ADC initiates an internal reset cycle which sets the D_{IN} word to all 0s ($S/D = 0/S = S0 = S1 = UNI = SLP = 0$). A write operation may be performed if the default state of the ADC's configuration is not desired. Otherwise, the ADC must be properly addressed and followed by a STOP condition to initiate a conversion.

Initiating a New Conversion

The LTC2309 awakens from either nap or sleep when properly addressed for a read/write operation. A STOP command may then be issued after performing the read/write operation to trigger a new conversion.

Issuing a STOP command after the 8th SCL clock pulse of the address frame and before the completion of a

read/write operation will also initiate new conversion, but the output result may not be valid due to lack of adequate acquisition time (see Acquisition section).

LTC2309 Address

The LTC2309 has two address pins (AD0 and AD1) that may be tied HIGH, LOW, or left floating to enable one of 9 possible addresses (see Table 2).

In addition to the configurable addresses listed in Table 2, the LTC2309 also contains a global address (1101011) which may be used for synchronizing multiple LTC2309s or other I²C LTC230X SAR ADCs (see Synchronizing Multiple LTC2309s with Global Address Call section).

Table 2. Address Assignment

AD1	AD0	ADDRESS
LOW	LOW	0001000
LOW	Float	0001001
LOW	HIGH	0001010
Float	HIGH	0001011
Float	Float	0011000
Float	LOW	0011001
HIGH	LOW	0011010
HIGH	Float	0011011
HIGH	HIGH	0101000

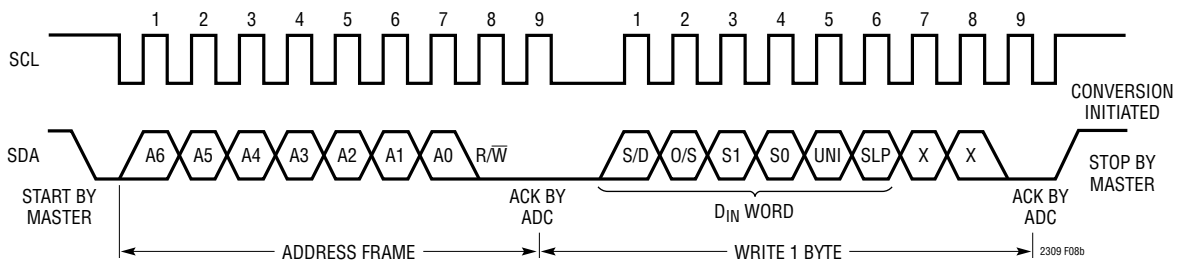

Figure 8b. Timing Diagram for Writing to the LTC2309

APPLICATIONS INFORMATION

Continuous Read

In applications where the same input channel is sampled each cycle, conversions can be continuously performed and read without a write cycle (see Figure 9). The D_{IN} word remains unchanged from the last value written into the device. If the device has not been written to since power-up, the D_{IN} word defaults to all 0s ($S/D = 0/S = S0 = S1 = UNI = SLP = 0$). At the end of a read operation, a STOP condition may be given to start a new conversion. At the conclusion of the conversion cycle, the next result may be read using the method described above. If the conversion cycle is not concluded and a valid address selects the device, the LTC2309 gener-

ates a NACK signal indicating the conversion cycle is in progress.

Continuous Read/Write

Once the conversion cycle is complete, the LTC2309 can be written to and then read from using the repeated START (Sr) command. Figure 10 shows a cycle which begins with a data write, a repeated START, followed by a read and concluded with a STOP command. After all 16 bits are read out, a conversion may be initiated by issuing a STOP command. The following conversion will be performed using the newly programmed data.

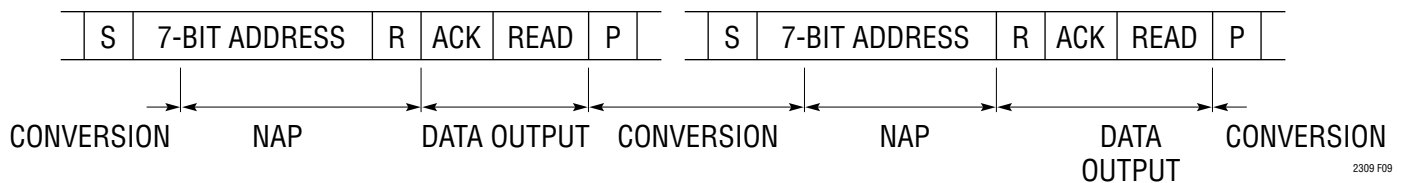

Figure 9. Consecutive Reading with the Same Configuration

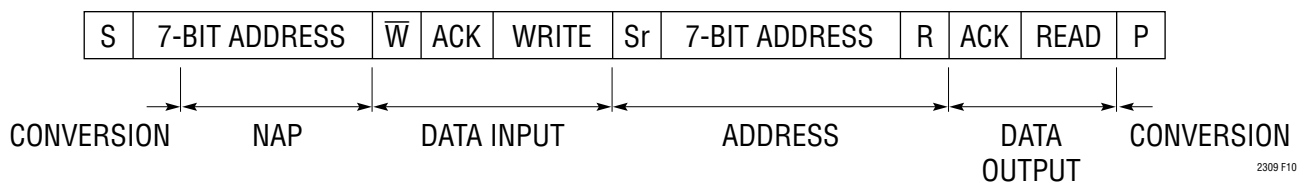

Figure 10. Write, Read, START Conversion

APPLICATIONS INFORMATION

Synchronizing Multiple LTC2309s with a Global Address Call

In applications where several LTC2309s or other I²C SAR ADCs from Linear Technology Corporation are used on the same I²C bus, all converters can be synchronized through the use of a global address call. Prior to issuing the global address call, all converters must have completed a conversion cycle. The master then issues a START, followed by the global address 1101011, and a write request. All converters will be selected and acknowledge the request. The master then sends a write byte (optional) followed by the STOP command. This will update the channel selection (optional) and simultaneously initiate a conversion for all ADCs on the bus (see Figure 11). In order to synchronize multiple converters without changing the channel, a STOP command may be issued after acknowledgement of the global write command. Global read commands are not allowed and the converters will NACK a global read request.

Nap Mode

The ADC enters nap mode after a conversion is complete (t_{CONV}) if the SLP bit is set to a logic 0. The supply current decreases to 210 μ A in nap mode between conversions, thereby reducing the average power dissipation as the sample rate decreases. For example, the LTC2309 draws an average of 300 μ A at a 1ksp/s sampling rate. The LTC2309 keeps only the reference (V_{REF}) and reference buffer (REFCOMP) circuitry active when in nap mode.

Sleep Mode

The ADC enters sleep mode after a conversion is complete (t_{CONV}) if the SLP bit is set to a logic 1. The ADC draws only 7 μ A in sleep mode, provided that none of the digital inputs are switching. When the LTC2309 is properly addressed, the ADC is released from sleep mode and requires 200ms ($t_{REFWAKE}$) to wake up and charge the respective 2.2 μ F and 10 μ F bypass capacitors on the V_{REF} and REFCOMP pins. A new conversion should not be initiated before this time, as shown in Figure 12.

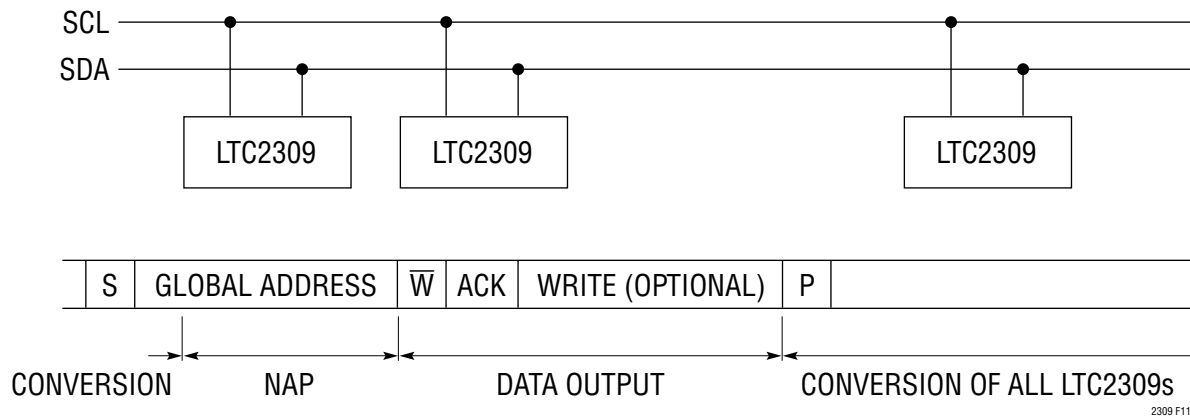

Figure 11. Synchronous Multiple LTC2309s with a Global Address Call

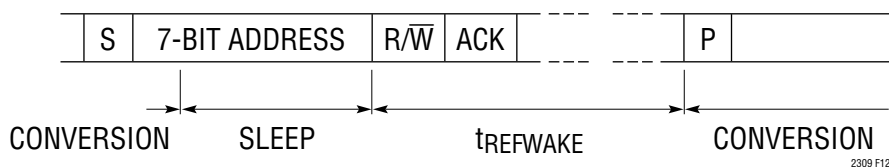

Figure 12. Exiting Sleep Mode and Starting a New Conversion

APPLICATIONS INFORMATION

Acquisition

The LTC2309 begins acquiring the input signal at different instances depending on whether a read or write operation is being performed. If a read operation is being performed, acquisition of the input signal begins on the rising edge of the 9th clock pulse following the address frame, as shown in Figure 13a.

If a write operation is being performed, acquisition of the input signal begins on the falling edge of the sixth clock cycle after the D_{IN} word has been shifted in, as shown in Figure 13b. The LTC2309 will acquire the signal from the input channel that was most recently programmed by the D_{IN} word. A minimum of 240ns is required to acquire the input signal before initiating a new conversion.

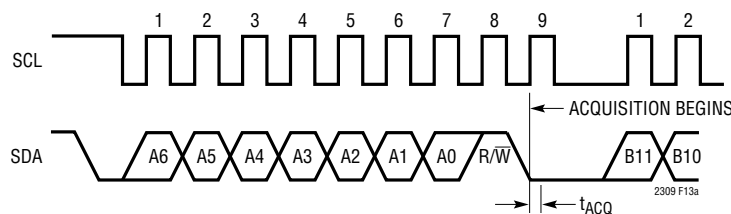

Figure 13a. Timing Diagram Showing Acquisition During a Read Operation

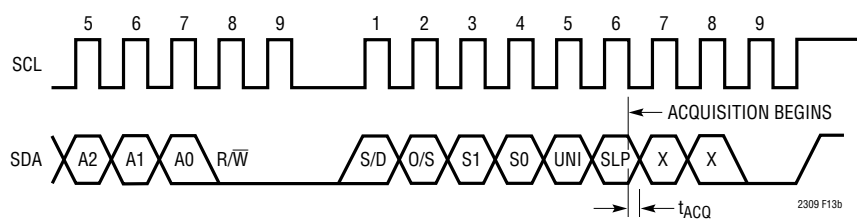

Figure 13b. Timing Diagram Showing Acquisition During a Write Operation

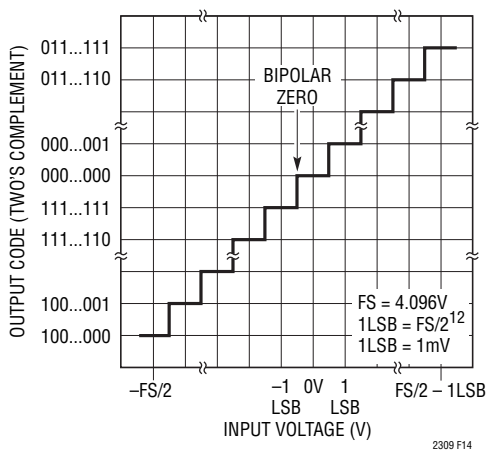

Figure 14. Bipolar Transfer Characteristics (2's Complement)

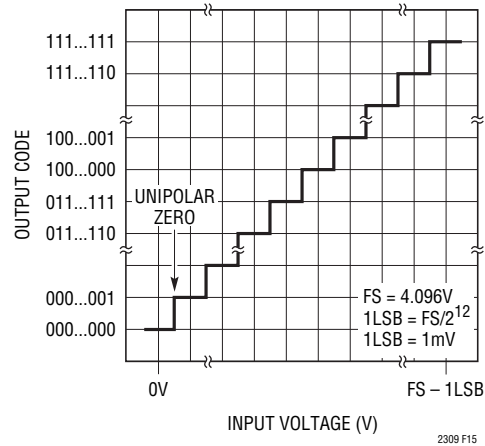

Figure 15. Unipolar Transfer Characteristics (Straight Binary)

APPLICATIONS INFORMATION

Board Layout and Bypassing

To obtain the best performance, a printed circuit board with a solid ground plane is required. Layout for the printed board should ensure digital and analog signal lines are separated as much as possible. Care should be taken not to run any digital signals alongside an analog signal. All analog inputs should be shielded by GND. V_{REF} , REFCOMP

and V_{DD} should be bypassed to the ground plane as close to the pin as possible. Maintaining a low impedance path for the common return of these bypass capacitors is essential to the low noise operation of the ADC. These traces should be as wide as possible. See Figures 16a-e for a suggested layout.

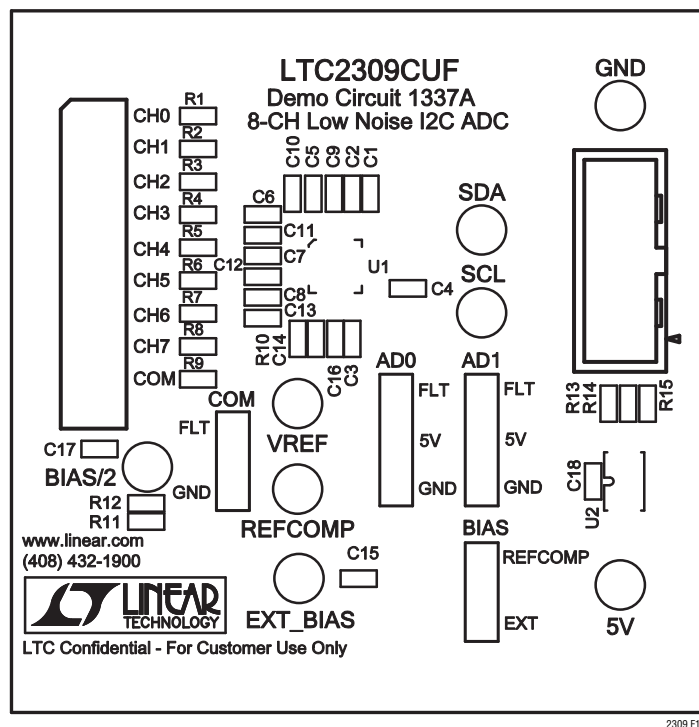
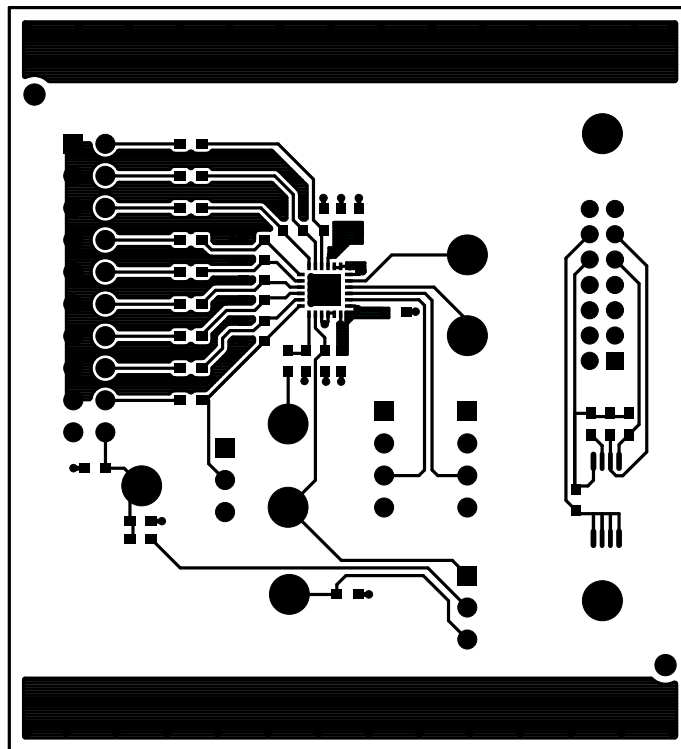

Figure 16a. Top Silkscreen

APPLICATIONS INFORMATION



2309 F16b

Figure 16b. Layer 1 Component Side

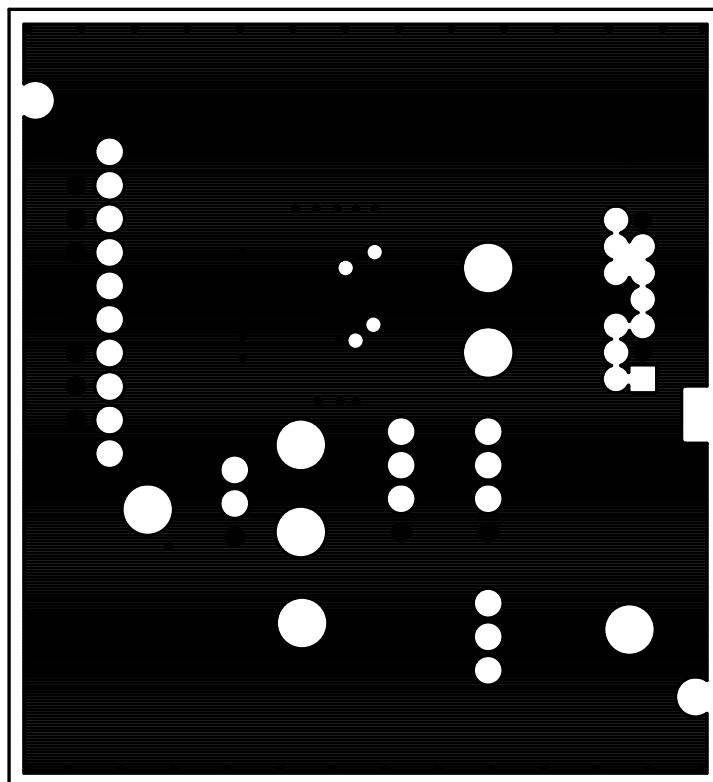

2309 F16c

Figure 16c. Layer 2 Ground Plane

2309fd

APPLICATIONS INFORMATION

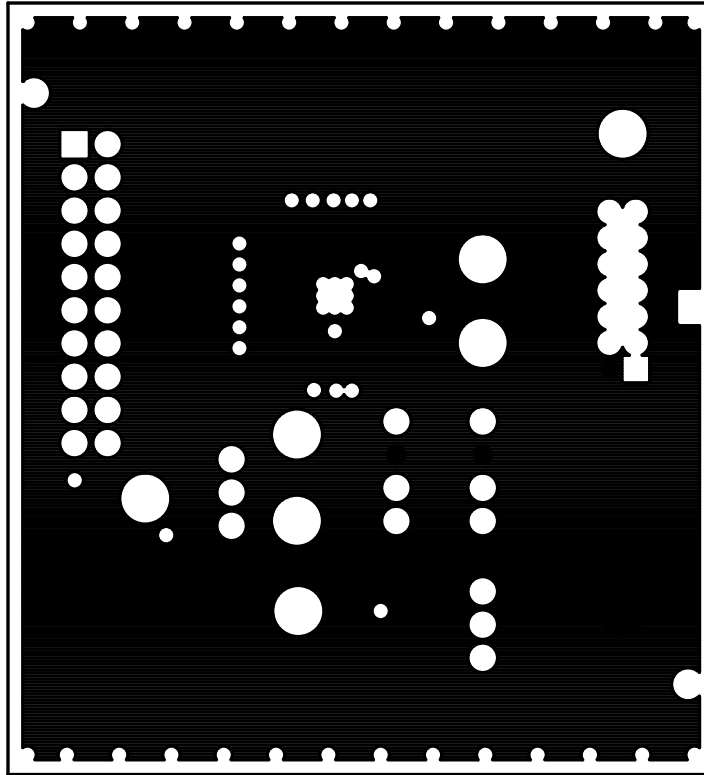

Figure 16d. Layer 3 Power Plane

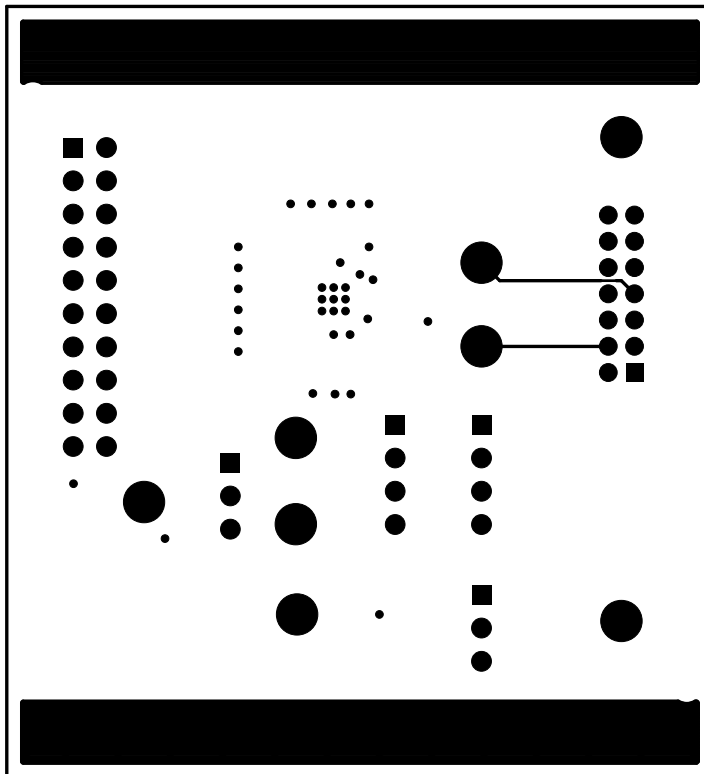
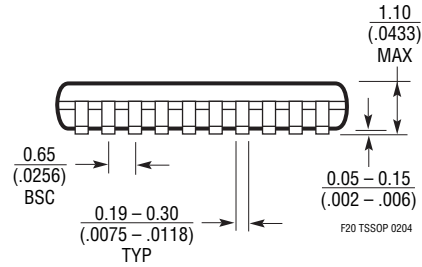
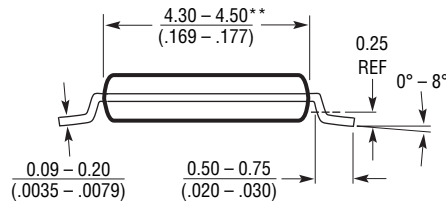
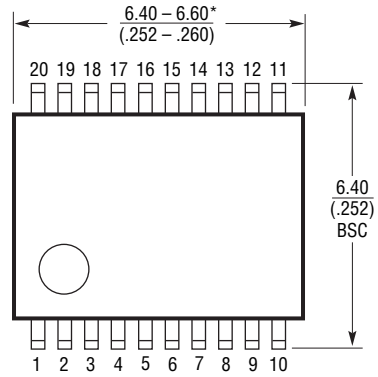
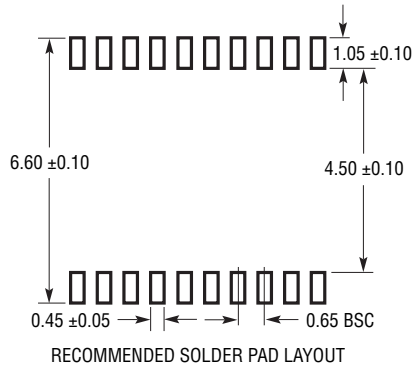

Figure 16e. Layer Back Solder Side

PACKAGE DESCRIPTION

F Package
20-Lead Plastic TSSOP (4.4mm)
 (Reference LTC DWG # 05-08-1650)



- NOTE:
1. CONTROLLING DIMENSION: MILLIMETERS
 2. DIMENSIONS ARE IN MILLIMETERS (INCHES)
 3. DRAWING NOT TO SCALE
- *DIMENSIONS DO NOT INCLUDE MOLD FLASH. MOLD FLASH SHALL NOT EXCEED .152mm (.006") PER SIDE
- **DIMENSIONS DO NOT INCLUDE INTERLEAD FLASH. INTERLEAD FLASH SHALL NOT EXCEED .254mm (.010") PER SIDE

REVISION HISTORY (Revision history begins at Rev D)

REV	DATE	DESCRIPTION	PAGE NUMBER
D	7/10	Revised Block Diagram	1
		Changed AV _{DD} and DV _{DD} pins to V _{DD} only	2, 4-9, 20
		Revised Note 2	5
		Consolidated AV _{DD} and DV _{DD} into V _{DD} and revised V _{REF} and REFCOMP pin descriptions in Pin Functions section	7, 8
		Revised Figures 6b and 6c and Internal Reference paragraph, and added text to I ² C Interface in Applications Information section	13, 14
		Changed NAK to NACK in Figure 8a	15
		Revised Typical Application	26

TYPICAL APPLICATION

Driving the LTC2309 with $\pm 10V$ Input Signals Using a Precision Attenuator

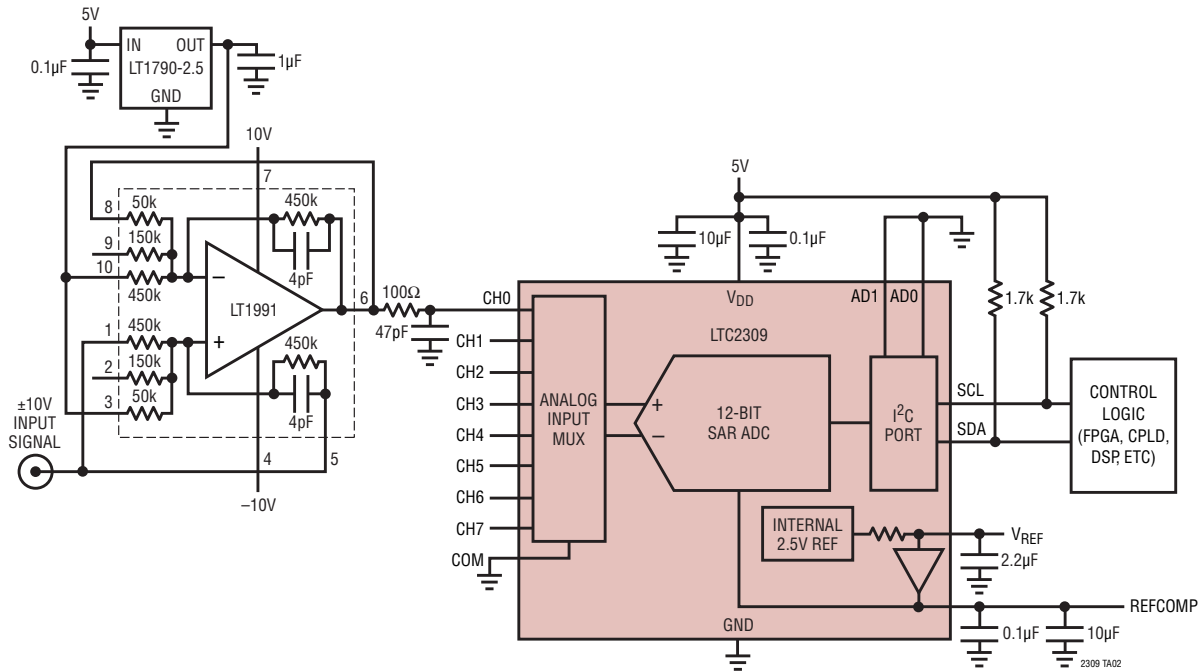

RELATED PARTS

PART NUMBER	DESCRIPTION	COMMENTS
LTC1417	14-Bit, 400ksps Serial ADC	20mW, Unipolar or Bipolar, Internal Reference, SSOP-16 Package
LTC1468/LTC1469	Single/Dual 90MHz, 22V/ μ s, 16-Bit Accurate Op Amps	Low Input Offset: 75 μ V/125 μ V
LTC1609	16-Bit, 200ksps Serial ADC	65mW, Configurable Bipolar and Unipolar Input Ranges, 5V Supply
LTC1790	Micropower Low Dropout Reference	60 μ A Supply Current, 10ppm/ $^{\circ}$ C, SOT-23 Package
LTC1850/LTC1851	10-Bit/12-Bit, 8-Channel, 1.25Msps ADCs	Parallel Output, Programmable MUX and Sequencer, 5V Supply
LTC1852/LTC1853	10-Bit/12-Bit, 8-Channel, 400ksps ADCs	Parallel Output, Programmable MUX and Sequencer, 3V or 5V Supply
LTC1860/LTC1861	12-Bit, 1-/2-Channel 250ksps ADCs in MSOP	850 μ A at 250ksps, 2 μ A at 1ksps, SO-8 and MSOP Packages
LTC1860L/LTC1861L	3V, 12-bit, 1-/2-Channel 150ksps ADCs	450 μ A at 150ksps, 10 μ A at 1ksps, SO-8 and MSOP Packages
LTC1863/LTC1867	12-/16-Bit, 8-Channel 200ksps ADCs	6.5mW, Unipolar or Bipolar, Internal Reference, SSOP-16 Package
LTC1863L/LTC1867L	3V, 12-/16-bit, 8-Channel 175ksps ADCs	2mW, Unipolar or Bipolar, Internal Reference, SSOP-16 Package
LTC1864/LTC1865	16-Bit, 1-/2-Channel 250ksps ADCs in MSOP	850 μ A at 250ksps, 2 μ A at 1ksps, SO-8 and MSOP Packages
LTC1864L/LTC1865L	3V, 16-Bit, 1-/2-Channel 150ksps ADCs in MSOP	450 μ A at 150ksps, 10 μ A at 1ksps, SO-8 and MSOP Packages
LTC2302/LTC2306	12-Bit, 1-/2-Channel 500ksps SPI ADCs in 3mm \times 3mm DFN	14mW at 500ksps, Single 5V Supply, Software Compatible with LTC2308
LTC2308	12-Bit, 8-Channel 500ksps SPI ADC	5V, Internal Reference, 4mm \times 4mm QFN Package, Software Compatible with LTC2302/LTC2306
LTC2453	Easy-to-Use, Ultratiny 16-Bit I ² C Delta Sigma ADC	2LSB INL, 50nA Sleep Current, 60Hz Output Rate, 3mm \times 2mm DFN Package
LTC2487/LTC2489/ LTC2493	2-/4-Channel Easy Drive™ I ² C Delta Sigma ADCs	16-/24 Bits, PGA and Temperature Sensor, 15Hz Output Rate, 4mm \times 3mm DFN Packages
LTC2495/LTC2497/ LTC2499	8-/16-Channel Easy Drive I ² C Delta Sigma ADCs	16-/24-Bits, PGA and Temperature Sensor, 15Hz Output Rate, 5mm \times 7mm QFN Packages

2309fd

Looking for pricing, stock, or lifecycle information?

Click below to explore more details on WIN SOURCE:

 [View LTC2309IUF#PBF on WIN SOURCE](#)

 [Analog Devices Inc. Information](#)

Optimize Your Supply Chain with WIN SOURCE Solutions

-  Global Sourcing Solution
-  Obsolete Management
-  Cost Control Management
-  Shortage Management
-  Alternative Solution
-  Excess Inventory Management