



**THE DATASHEET OF
LTC2418IGN#PBF**



FEATURES

- **8-/16-Channel Single-Ended or 4-/8-Channel Differential Inputs (LTC2414/LTC2418)**
- **Low Supply Current (200 μ A, 4 μ A in Autosleep)**
- **Differential Input and Differential Reference with GND to V_{CC} Common Mode Range**
- **2ppm INL, No Missing Codes**
- **2.5ppm Full-Scale Error and 0.5ppm Offset**
- **0.2ppm Noise**
- **No Latency: Digital Filter Settles in a Single Cycle Each Conversion Is Accurate, Even After a New Channel Is Selected**
- **Single Supply 2.7V to 5.5V Operation**
- **Internal Oscillator—No External Components Required**
- **110dB Min, 50Hz/60Hz Notch Filter**

APPLICATIONS

- Direct Sensor Digitizer
- Weight Scales
- Direct Temperature Measurement
- Gas Analyzers
- Strain Gauge Transducers
- Instrumentation
- Data Acquisition
- Industrial Process Control

DESCRIPTION

The **LTC[®]2414/LTC2418** are 8-/16-channel (4-/8-differential) micropower 24-bit $\Delta\Sigma$ analog-to-digital converters. They operate from 2.7V to 5.5V and include an integrated oscillator, 2ppm INL and 0.2ppm RMS noise. They use delta-sigma technology and provide single cycle settling time for multiplexed applications. Through a single pin, the LTC2414/LTC2418 can be configured for better than 110dB differential mode rejection at 50Hz or 60Hz \pm 2%, or they can be driven by an external oscillator for a user-defined rejection frequency. The internal oscillator requires no external frequency setting components.

The LTC2414/LTC2418 accept any external differential reference voltage from 0.1V to V_{CC} for flexible ratiometric and remote sensing measurement applications. They can be configured to take 4/8 differential channels or 8/16 single-ended channels. The full-scale bipolar input range is from $-0.5V_{REF}$ to $0.5V_{REF}$. The reference common mode voltage, V_{REFCM} , and the input common mode voltage, V_{INCM} , may be independently set within GND to V_{CC} . The DC common mode input rejection is better than 140dB.

The LTC2414/LTC2418 communicate through a flexible 4-wire digital interface that is compatible with SPI and MICROWIRE protocols.

LT, LT, LTC, LTM, Linear Technology and the Linear logo are registered trademarks and No Latency $\Delta\Sigma$ is a trademark of Linear Technology Corporation. All other trademarks are the property of their respective owners.

TYPICAL APPLICATION

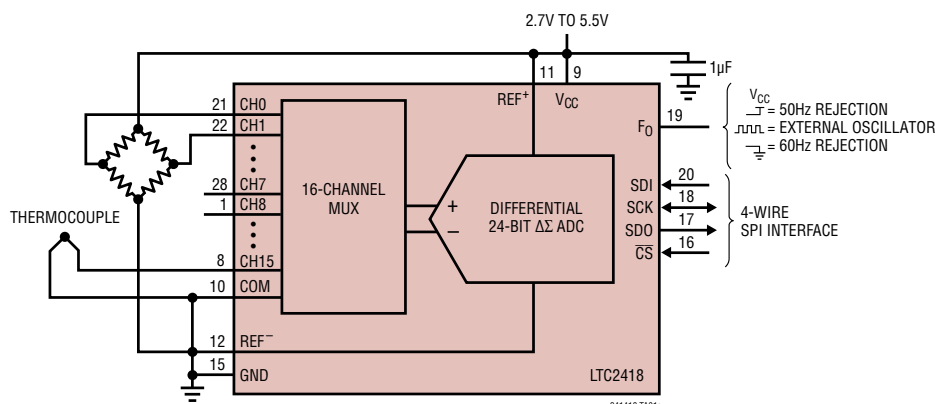

Total Unadjusted Error vs Input Voltage

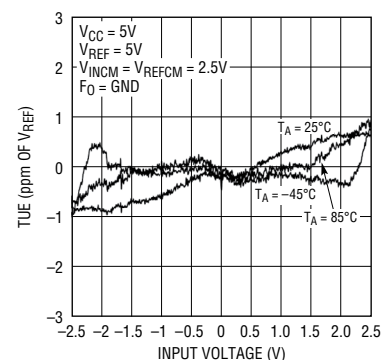

LTC2414/LTC2418

ABSOLUTE MAXIMUM RATINGS (Notes 1, 2)

Supply Voltage (V_{CC}) to GND	-0.3V to 7V	Operating Temperature Range	
Analog Input Voltage to GND	-0.3V to ($V_{CC} + 0.3V$)	LTC2414/LTC2418C	0°C to 70°C
Reference Input Voltage to GND ...	-0.3V to ($V_{CC} + 0.3V$)	LTC2414/LTC2418I	-40°C to 85°C
Digital Input Voltage to GND	-0.3V to ($V_{CC} + 0.3V$)	Storage Temperature Range	-65°C to 150°C
Digital Output Voltage to GND	-0.3V to ($V_{CC} + 0.3V$)	Lead Temperature (Soldering, 10 sec)	300°C

PIN CONFIGURATION

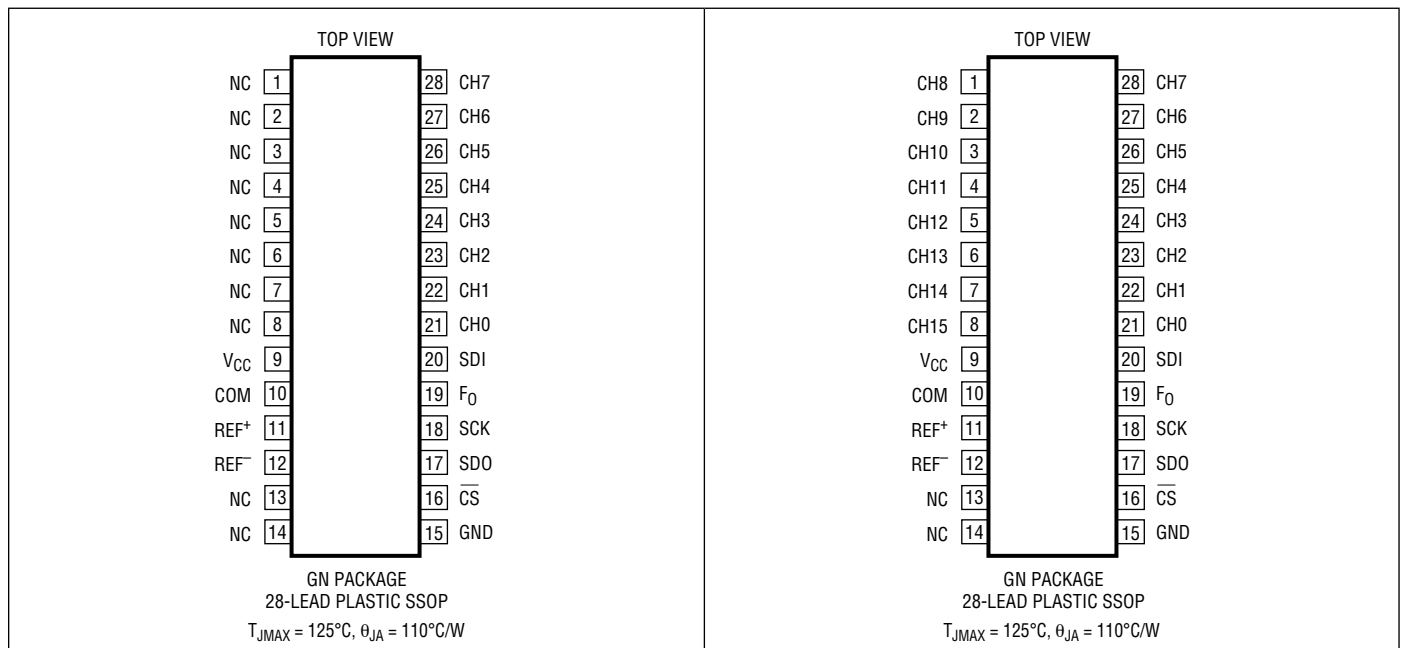

ORDER INFORMATION

LEAD FREE FINISH	TAPE AND REEL	PART MARKING*	PACKAGE DESCRIPTION	TEMPERATURE RANGE
LTC2414CGN#PBF	LTC2414CGN#TRPBF	2414	28-Lead Plastic SSOP	0°C to 70°C
LTC2414IGN#PBF	LTC2414IGN#TRPBF	2414	28-Lead Plastic SSOP	-40°C to 85°C
LTC2418CGN#PBF	LTC2418CGN#TRPBF	2418	28-Lead Plastic SSOP	0°C to 70°C
LTC2418IGN#PBF	LTC2418IGN#TRPBF	2418	28-Lead Plastic SSOP	-40°C to 85°C

Consult LTC Marketing for parts specified with wider operating temperature ranges. *The temperature grade is identified by a label on the shipping container. Consult LTC Marketing for information on nonstandard lead based finish parts.

For more information on lead free part marking, go to: <http://www.linear.com/leadfree/>

For more information on tape and reel specifications, go to: <http://www.linear.com/tapeandreel/>

ELECTRICAL CHARACTERISTICS

The ● denotes specifications which apply over the full operating temperature range, otherwise specifications are at $T_A = 25^\circ\text{C}$. (Notes 3, 4)

PARAMETER	CONDITIONS	MIN	TYP	MAX	UNITS
Resolution (No Missing Codes)	$0.1\text{V} \leq V_{\text{REF}} \leq V_{\text{CC}}$, $-0.5 \cdot V_{\text{REF}} \leq V_{\text{IN}} \leq 0.5 \cdot V_{\text{REF}}$ (Note 5)	●	24		Bits
Integral Nonlinearity	$4.5\text{V} \leq V_{\text{CC}} \leq 5.5\text{V}$, $\text{REF}^+ = 2.5\text{V}$, $\text{REF}^- = \text{GND}$, $V_{\text{INCM}} = 1.25\text{V}$ (Note 6) $5\text{V} \leq V_{\text{CC}} \leq 5.5\text{V}$, $\text{REF}^+ = 5\text{V}$, $\text{REF}^- = \text{GND}$, $V_{\text{INCM}} = 2.5\text{V}$ (Note 6) $\text{REF}^+ = 2.5\text{V}$, $\text{REF}^- = \text{GND}$, $V_{\text{INCM}} = 1.25\text{V}$ (Note 6)	●	1 2 5	14	ppm of V_{REF} ppm of V_{REF} ppm of V_{REF}
Offset Error	$2.5\text{V} \leq \text{REF}^+ \leq V_{\text{CC}}$, $\text{REF}^- = \text{GND}$, $\text{GND} \leq \text{IN}^+ = \text{IN}^- \leq V_{\text{CC}}$ (Note 14)	●	2.5	10	μV
Offset Error Drift	$2.5\text{V} \leq \text{REF}^+ \leq V_{\text{CC}}$, $\text{REF}^- = \text{GND}$, $\text{GND} \leq \text{IN}^+ = \text{IN}^- \leq V_{\text{CC}}$		20		$\text{nV}/^\circ\text{C}$
Positive Full-Scale Error	$2.5\text{V} \leq \text{REF}^+ \leq V_{\text{CC}}$, $\text{REF}^- = \text{GND}$, $\text{IN}^+ = 0.75 \cdot \text{REF}^+$, $\text{IN}^- = 0.25 \cdot \text{REF}^+$	●	2.5	12	ppm of V_{REF}
Positive Full-Scale Error Drift	$2.5\text{V} \leq \text{REF}^+ \leq V_{\text{CC}}$, $\text{REF}^- = \text{GND}$, $\text{IN}^+ = 0.75 \cdot \text{REF}^+$, $\text{IN}^- = 0.25 \cdot \text{REF}^+$		0.03		ppm of $V_{\text{REF}}/^\circ\text{C}$
Negative Full-Scale Error	$2.5\text{V} \leq \text{REF}^+ \leq V_{\text{CC}}$, $\text{REF}^- = \text{GND}$, $\text{IN}^+ = 0.25 \cdot \text{REF}^+$, $\text{IN}^- = 0.75 \cdot \text{REF}^+$	●	2.5	12	ppm of V_{REF}
Negative Full-Scale Error Drift	$2.5\text{V} \leq \text{REF}^+ \leq V_{\text{CC}}$, $\text{REF}^- = \text{GND}$, $\text{IN}^+ = 0.25 \cdot \text{REF}^+$, $\text{IN}^- = 0.75 \cdot \text{REF}^+$		0.03		ppm of $V_{\text{REF}}/^\circ\text{C}$
Total Unadjusted Error	$4.5\text{V} \leq V_{\text{CC}} \leq 5.5\text{V}$, $\text{REF}^+ = 2.5\text{V}$, $\text{REF}^- = \text{GND}$, $V_{\text{INCM}} = 1.25\text{V}$ $5\text{V} \leq V_{\text{CC}} \leq 5.5\text{V}$, $\text{REF}^+ = 5\text{V}$, $\text{REF}^- = \text{GND}$, $V_{\text{INCM}} = 2.5\text{V}$ $\text{REF}^+ = 2.5\text{V}$, $\text{REF}^- = \text{GND}$, $V_{\text{INCM}} = 1.25\text{V}$		3 3 6		ppm of V_{REF} ppm of V_{REF} ppm of V_{REF}
Output Noise	$5\text{V} \leq V_{\text{CC}} \leq 5.5\text{V}$, $\text{REF}^+ = 5\text{V}$, $V_{\text{REF}^-} = \text{GND}$, $\text{GND} \leq \text{IN}^- = \text{IN}^+ \leq 5\text{V}$ (Note 13)		1		μV_{RMS}

CONVERTER CHARACTERISTICS

The ● denotes specifications which apply over the full operating temperature range, otherwise specifications are at $T_A = 25^\circ\text{C}$. (Notes 3, 4)

PARAMETER	CONDITIONS	MIN	TYP	MAX	UNITS
Input Common Mode Rejection DC	$2.5\text{V} \leq \text{REF}^+ \leq V_{\text{CC}}$, $\text{REF}^- = \text{GND}$, $\text{GND} \leq \text{IN}^- = \text{IN}^+ \leq 5\text{V}$ (Note 5)	●	130	140	dB
Input Common Mode Rejection 60Hz $\pm 2\%$	$2.5\text{V} \leq \text{REF}^+ \leq V_{\text{CC}}$, $\text{REF}^- = \text{GND}$, $\text{GND} \leq \text{IN}^- = \text{IN}^+ \leq 5\text{V}$ (Notes 5, 7)	●	140		dB
Input Common Mode Rejection 50Hz $\pm 2\%$	$2.5\text{V} \leq \text{REF}^+ \leq V_{\text{CC}}$, $\text{REF}^- = \text{GND}$, $\text{GND} \leq \text{IN}^- = \text{IN}^+ \leq 5\text{V}$ (Notes 5, 8)	●	140		dB
Input Normal Mode Rejection 60Hz $\pm 2\%$	(Notes 5, 7)	●	110	140	dB
Input Normal Mode Rejection 50Hz $\pm 2\%$	(Notes 5, 8)	●	110	140	dB
Reference Common Mode Rejection DC	$2.5\text{V} \leq \text{REF}^+ \leq V_{\text{CC}}$, $\text{GND} \leq \text{REF}^- \leq 2.5\text{V}$, $V_{\text{REF}} = 2.5\text{V}$, $\text{IN}^- = \text{IN}^+ = \text{GND}$ (Note 5)	●	130	140	dB
Power Supply Rejection, DC	$\text{REF}^+ = 2.5\text{V}$, $\text{REF}^- = \text{GND}$, $\text{IN}^- = \text{IN}^+ = \text{GND}$		110		dB
Power Supply Rejection, 60Hz $\pm 2\%$	$\text{REF}^+ = 2.5\text{V}$, $\text{REF}^- = \text{GND}$, $\text{IN}^- = \text{IN}^+ = \text{GND}$ (Note 7)		120		dB
Power Supply Rejection, 50Hz $\pm 2\%$	$\text{REF}^+ = 2.5\text{V}$, $\text{REF}^- = \text{GND}$, $\text{IN}^- = \text{IN}^+ = \text{GND}$ (Note 8)		120		dB

LTC2414/LTC2418

ANALOG INPUT AND REFERENCE

The ● denotes specifications which apply over the full operating temperature range, otherwise specifications are at $T_A = 25^\circ\text{C}$. (Note 3)

SYMBOL	PARAMETER	CONDITIONS		MIN	TYP	MAX	UNITS
IN ⁺	Absolute/Common Mode IN ⁺ Voltage		●	GND – 0.3		V _{CC} + 0.3	V
IN ⁻	Absolute/Common Mode IN ⁻ Voltage		●	GND – 0.3		V _{CC} + 0.3	V
V _{IN}	Input Differential Voltage Range (IN ⁺ – IN ⁻)		●	-V _{REF} /2		-V _{REF} /2	V
REF ⁺	Absolute/Common Mode REF ⁺ Voltage		●	0.1		V _{CC}	V
REF ⁻	Absolute/Common Mode REF ⁻ Voltage		●	GND		V _{CC} – 0.1	V
V _{REF}	Reference Differential Voltage Range (REF ⁺ – REF ⁻)		●	0.1		V _{CC}	V
C _S (IN ⁺)	IN ⁺ Sampling Capacitance				18		pF
C _S (IN ⁻)	IN ⁻ Sampling Capacitance				18		pF
C _S (REF ⁺)	REF ⁺ Sampling Capacitance				18		pF
C _S (REF ⁻)	REF ⁻ Sampling Capacitance				18		pF
I _{DC_LEAK} (IN ⁺)	IN ⁺ DC Leakage Current	$\overline{CS} = V_{CC} = 5.5\text{V}$, IN ⁺ = GND	●	-10	1	10	nA
I _{DC_LEAK} (IN ⁻)	IN ⁻ DC Leakage Current	$\overline{CS} = V_{CC} = 5.5\text{V}$, IN ⁻ = 5V	●	-10	1	10	nA
I _{DC_LEAK} (REF ⁺)	REF ⁺ DC Leakage Current	$\overline{CS} = V_{CC} = 5.5\text{V}$, REF ⁺ = 5V	●	-10	1	10	nA
I _{DC_LEAK} (REF ⁻)	REF ⁻ DC Leakage Current	$\overline{CS} = V_{CC} = 5.5\text{V}$, REF ⁻ = GND	●	-10	1	10	nA
	Off Channel to In Channel Isolation (R _{IN} = 100Ω)	DC			140		dB
		1Hz			140		dB
		f _S = 15,3600Hz			140		dB
t _{OPEN}	MUX Break-Before-Make Interval	2.7V ≤ V _{CC} ≤ 5.5V		70	100	300	ns
I _{S(OFF)}	Channel Off Leakage Current	Channel at V _{CC} and GND	●	-10	1	10	nA

DIGITAL INPUT AND DIGITAL OUTPUTS

The ● denotes specifications which apply over the full operating temperature range, otherwise specifications are at $T_A = 25^\circ\text{C}$. (Note 3)

SYMBOL	PARAMETER	CONDITIONS		MIN	TYP	MAX	UNITS
V _{IH}	High Level Input Voltage	2.7V ≤ V _{CC} ≤ 5.5V	●	2.5			V
		\overline{CS} , F ₀ , SDI		2.0			V
V _{IL}	Low Level Input Voltage	4.5V ≤ V _{CC} ≤ 5.5V	●			0.8	v
		2.7V ≤ V _{CC} ≤ 5.5V				0.6	v
V _{IH}	High Level Input Voltage	2.7V ≤ V _{CC} ≤ 5.5V (Note 9)	●	2.5			V
		2.7V ≤ V _{CC} ≤ 3.3V (Note 9)		2.0			V
V _{IL}	Low Level Input Voltage	4.5V ≤ V _{CC} ≤ 5.5V (Note 9)	●			0.8	V
		2.7V ≤ V _{CC} ≤ 5.5V (Note 9)				0.6	V
I _{IN}	Digital Input Current	0V ≤ V _{IN} ≤ V _{CC}	●	-10		10	μA
		\overline{CS} , F ₀ , SDI					
	Digital Input Current	0V ≤ V _{IN} ≤ V _{CC} (Note 9)	●	-10		10	μA
		SCK					
C _{IN}	Digital Input Capacitance				10		pF
		\overline{CS} , F ₀ , SDI					
	Digital Input Capacitance	(Note 9)			10		pF
		SCK					
V _{OH}	High Level Output Voltage	I _O = -800μA	●	V _{CC} -0.5			V
		SDO					

241418fb

DIGITAL INPUT AND DIGITAL OUTPUTS

The ● denotes specifications which apply over the full operating temperature range, otherwise specifications are at $T_A = 25^\circ\text{C}$. (Note 3)

SYMBOL	PARAMETER	CONDITIONS	MIN	TYP	MAX	UNITS
V_{OL}	Low Level Output Voltage SDO	$I_O = 1.6\text{mA}$			0.4	V
V_{OH}	High Level Output Voltage SCK	$I_O = -800\mu\text{A}$ (Note 10)	$V_{CC} - 0.5$			V
V_{OL}	Low Level Output Voltage SCK	$I_O = 1.6\text{mA}$ (Note 10)			0.4	V
I_{OZ}	Hi-Z Output Leakage SDO		-10		10	μA

POWER REQUIREMENTS

The ● denotes specifications which apply over the full operating temperature range, otherwise specifications are at $T_A = 25^\circ\text{C}$. (Note 3)

SYMBOL	PARAMETER	CONDITIONS	MIN	TYP	MAX	UNITS
V_{CC}	Supply Voltage		2.7		5.5	V
I_{CC}	Supply Current					
	Conversion Mode	$\overline{CS} = 0\text{V}$ (Note 12)		200	300	μA
	Sleep Mode	$\overline{CS} = V_{CC}$ (Note 12)		4	10	μA
	Sleep Mode	$\overline{CS} = V_{CC}$, $2.7\text{V} \leq V_{CC} \leq 3.3\text{V}$ (Note 12)		2		μA

TIMING CHARACTERISTICS

The ● denotes specifications which apply over the full operating temperature range, otherwise specifications are at $T_A = 25^\circ\text{C}$. (Note 3)

SYMBOL	PARAMETER	CONDITIONS	MIN	TYP	MAX	UNITS
f_{EOSC}	External Oscillator Frequency Range		2.56		500	kHz
t_{HEO}	External Oscillator High Period		0.25		390	μs
t_{LEO}	External Oscillator Low Period		0.25		390	μs
t_{CONV}	Conversion Time	$F_0 = 0\text{V}$	130.86	133.53	136.20	ms
		$F_0 = V_{CC}$	157.03	160.23	163.44	ms
		External Oscillator (Note 11)		$20510/f_{EOSC}$ (in kHz)		ms
f_{ISCK}	Internal SCK Frequency	Internal Oscillator (Note 10)		19.2		kHz
		External Oscillator (Notes 10, 11)		$f_{EOSC}/8$		kHz
D_{ISCK}	Internal SCK Duty Cycle	(Note 10)	45		55	%
f_{ESCK}	External SCK Frequency Range	(Note 9)			2000	kHz
t_{LESCK}	External SCK Low Period	(Note 9)	250			ns
t_{HESCK}	External SCK High Period	(Note 9)	250			ns
t_{DOUT_ISCK}	Internal SCK 32-Bit Data Output Time	Internal Oscillator (Notes 10, 12)	1.64	1.67	1.70	ms
		External Oscillator (Notes 10, 11)		$256/f_{EOSC}$ (in kHz)		ms
t_{DOUT_ESCK}	External SCK 32-Bit Data Output Time	(Note 9)		$32/f_{ESCK}$ (in kHz)		ms

TIMING CHARACTERISTICS

The ● denotes specifications which apply over the full operating temperature range, otherwise specifications are at $T_A = 25^\circ\text{C}$. (Note 3)

SYMBOL	PARAMETER	CONDITIONS		MIN	TYP	MAX	UNITS
t_1	$\overline{\text{CS}} \downarrow$ to SDO Low		●	0		200	ns
t_2	$\overline{\text{CS}} \uparrow$ to SDO High Z		●	0		200	ns
t_3	$\overline{\text{CS}} \downarrow$ to SCK \downarrow	(Note 10)	●	0		200	ns
t_4	$\overline{\text{CS}} \downarrow$ to SCK \uparrow	(Note 9)	●	50			ns
t_{KQMAX}	SCK \downarrow to SDO Valid		●			220	ns
t_{KQMIN}	SDO Hold After SCK \downarrow	(Note 5)	●	15			ns
t_5	SCK Set-Up Before $\overline{\text{CS}} \downarrow$		●	50			ns
t_6	SCK Hold After $\overline{\text{CS}} \downarrow$		●			50	ns
t_7	SDI Setup Before SCK \uparrow	(Note 5)	●	100			ns
t_8	SDI Hold After SCK \uparrow	(Note 5)	●	100			ns

Note 1: Stresses beyond those listed under Absolute Maximum Ratings may cause permanent damage to the device. Exposure to any Absolute Maximum Rating condition for extended periods may affect device reliability and lifetime.

Note 2: All voltage values are with respect to GND.

Note 3: $V_{\text{CC}} = 2.7\text{V}$ to 5.5V unless otherwise specified.
 $V_{\text{REF}} = \text{REF}^+ - \text{REF}^-$, $V_{\text{REFCM}} = (\text{REF}^+ + \text{REF}^-)/2$; $V_{\text{IN}} = \text{IN}^+ - \text{IN}^-$,
 $V_{\text{INCM}} = (\text{IN}^+ + \text{IN}^-)/2$, IN^+ and IN^- are defined as the selected positive and negative input respectively.

Note 4: F_0 pin tied to GND or to V_{CC} or to external conversion clock source with $f_{\text{EOSC}} = 153600\text{Hz}$ unless otherwise specified.

Note 5: Guaranteed by design, not subject to test.

Note 6: Integral nonlinearity is defined as the deviation of a code from a straight line passing through the actual endpoints of the transfer curve. The deviation is measured from the center of the quantization band.

Note 7: $F_0 = 0\text{V}$ (internal oscillator) or $f_{\text{EOSC}} = 153600\text{Hz} \pm 2\%$ (external oscillator).

Note 8: $F_0 = V_{\text{CC}}$ (internal oscillator) or $f_{\text{EOSC}} = 128000\text{Hz} \pm 2\%$ (external oscillator).

Note 9: The converter is in external SCK mode of operation such that the SCK pin is used as digital input. The frequency of the clock signal driving SCK during the data output is f_{ESCK} and is expressed in kHz.

Note 10: The converter is in internal SCK mode of operation such that the SCK pin is used as digital output. In this mode of operation the SCK pin has a total equivalent load capacitance $C_{\text{LOAD}} = 20\text{pF}$.

Note 11: The external oscillator is connected to the F_0 pin. The external oscillator frequency, f_{EOSC} , is expressed in kHz.

Note 12: The converter uses the internal oscillator.
 $F_0 = 0\text{V}$ or $F_0 = V_{\text{CC}}$.

Note 13: The output noise includes the contribution of the internal calibration operations.

Note 14: Guaranteed by design and test correlation.

TYPICAL PERFORMANCE CHARACTERISTICS

Total Unadjusted Error
($V_{CC} = 5V$, $V_{REF} = 5V$)

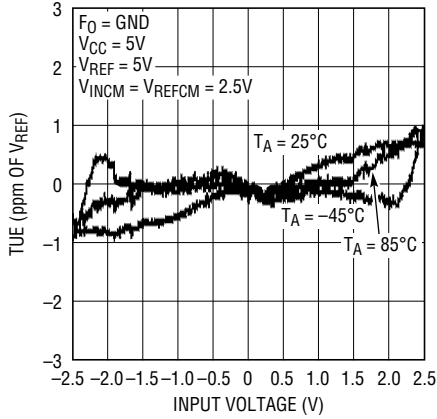

241418 G01

Total Unadjusted Error
($V_{CC} = 5V$, $V_{REF} = 2.5V$)

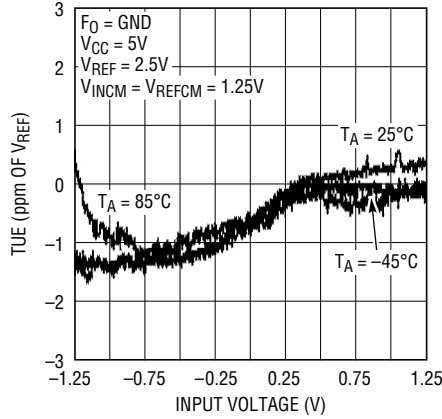

241418 G02

Total Unadjusted Error
($V_{CC} = 2.7V$, $V_{REF} = 2.5V$)

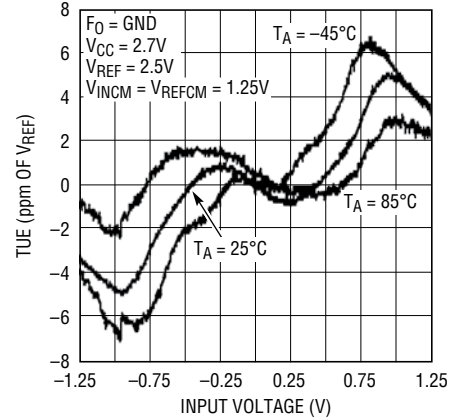

241418 G03

Integral Nonlinearity
($V_{CC} = 5V$, $V_{REF} = 5V$)

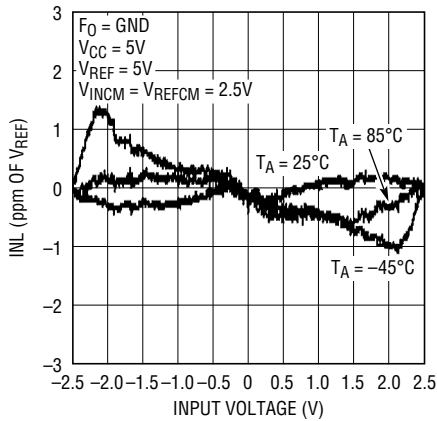

241418 G04

Integral Nonlinearity
($V_{CC} = 5V$, $V_{REF} = 2.5V$)

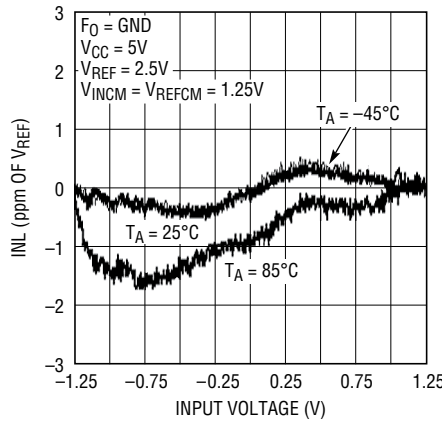

241418 G05

Integral Nonlinearity
($V_{CC} = 2.7V$, $V_{REF} = 2.5V$)

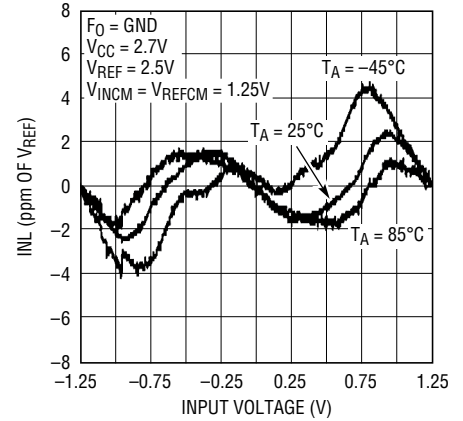

241418 G06

Noise Histogram
($V_{CC} = 5V$, $V_{REF} = 5V$)

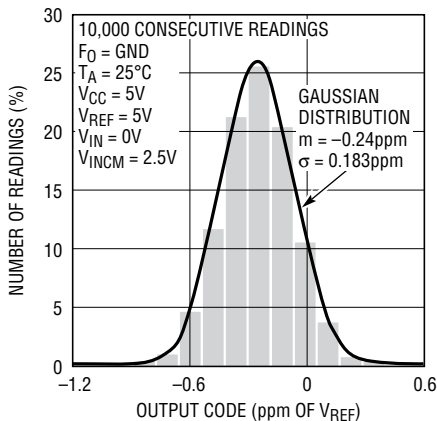

241418 G07

Noise Histogram
($V_{CC} = 2.7V$, $V_{REF} = 2.5V$)

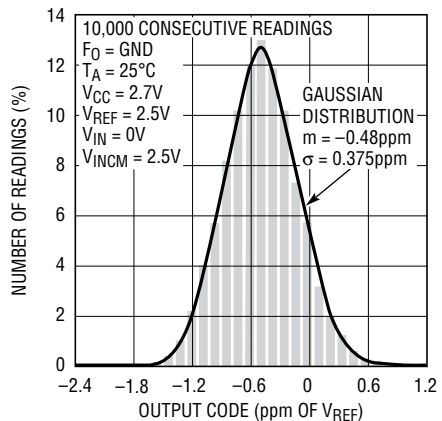

241418 G08

Long Term ADC Readings

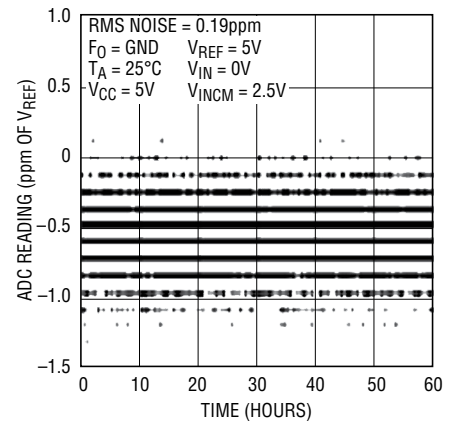

LTXXXX • TPCXX

TYPICAL PERFORMANCE CHARACTERISTICS

RMS Noise vs Input Differential Voltage

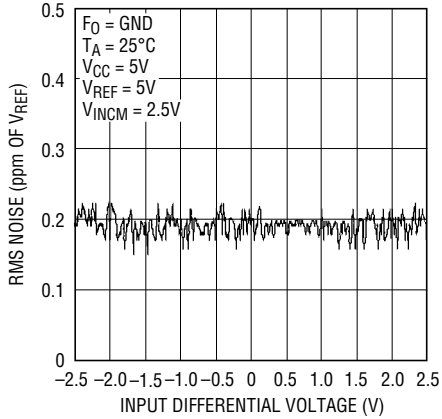

241418 G10

RMS Noise vs V_{INCM}

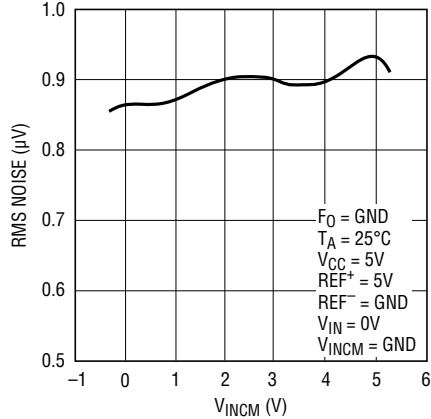

241418 G11

RMS Noise vs Temperature (T_A)

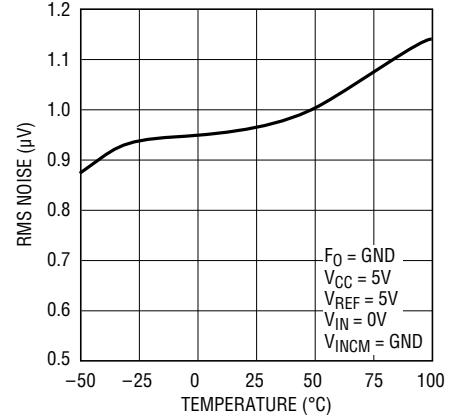

241418 G12

RMS Noise vs V_{CC}

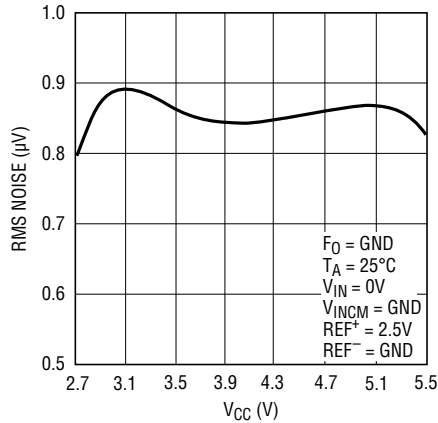

241418 G13

RMS Noise vs V_{REF}

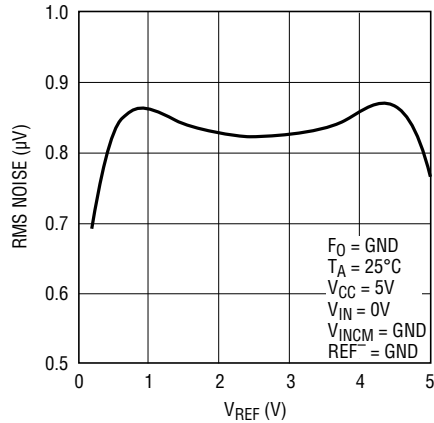

241418 G14

Offset Error vs V_{INCM}

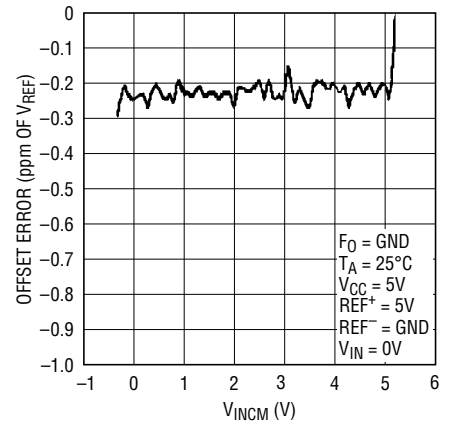

241418 G15

Offset Error vs Temperature

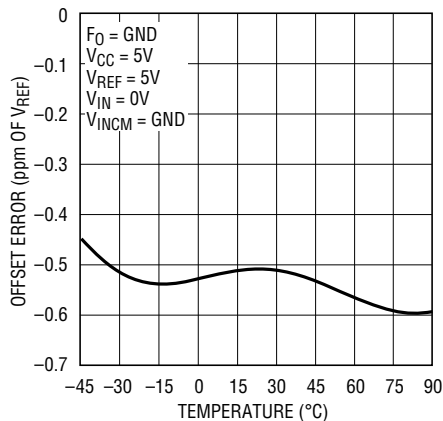

241418 G16

Offset Error vs V_{CC}

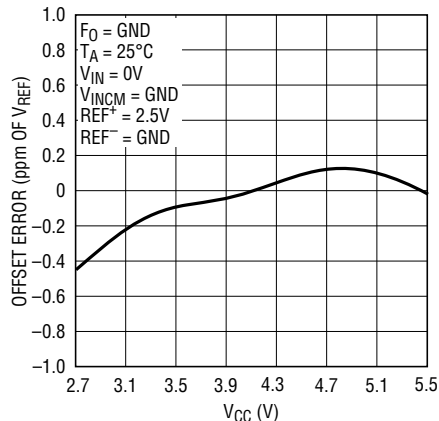

241418 G17

Offset Error vs V_{REF}

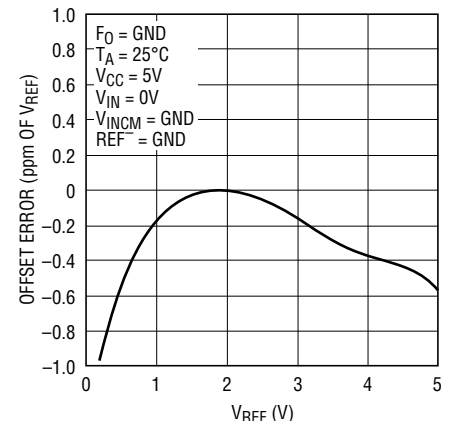

241418 G18

241418fb

TYPICAL PERFORMANCE CHARACTERISTICS

Full-Scale Error vs Temperature

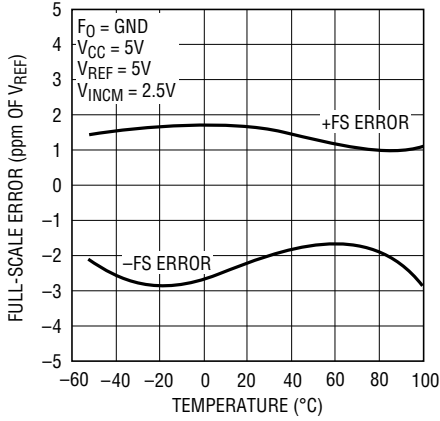

241418 G19

Full-Scale Error vs VCC

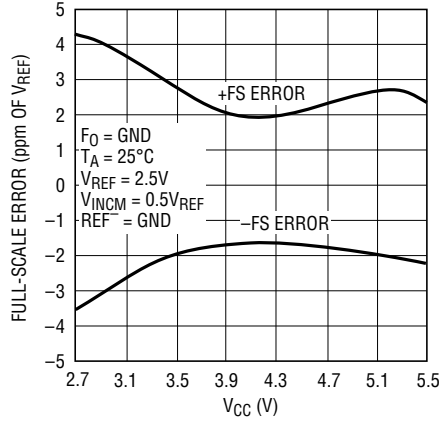

241418 G20

Full-Scale Error vs VREF

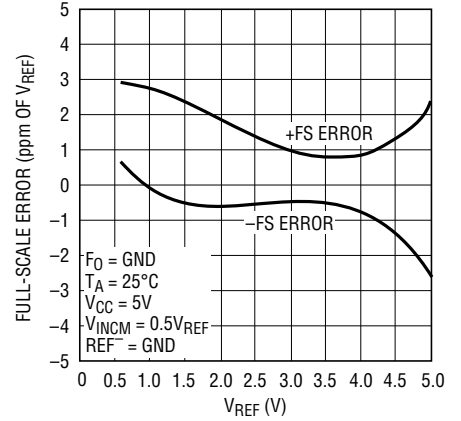

241418 G21

PSRR vs Frequency at VCC

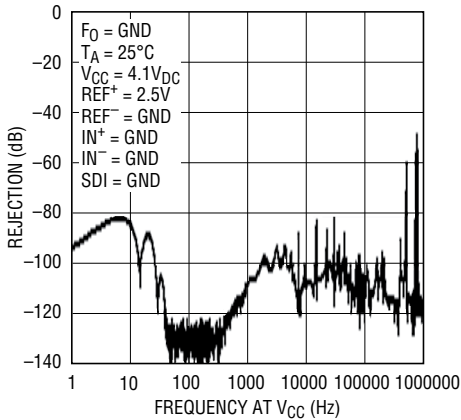

241418 G22

PSRR vs Frequency at VCC

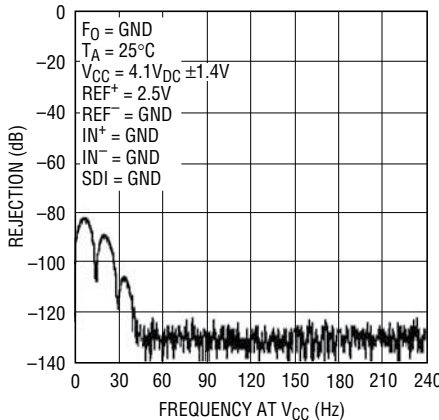

241418 G23

PSRR vs Frequency at VCC

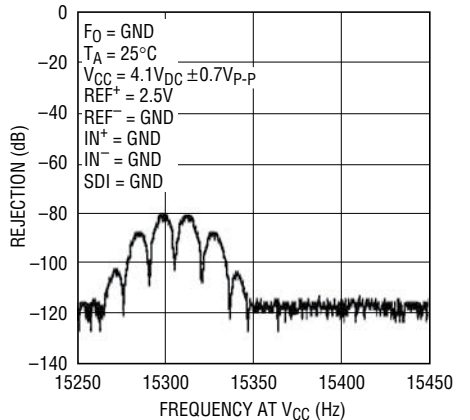

241418 G24

Conversion Current vs Temperature

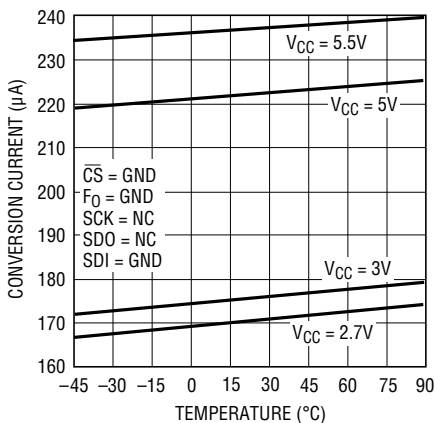

241418 G25

Supply Current at Elevated Output Rates (F0 Over Driven)

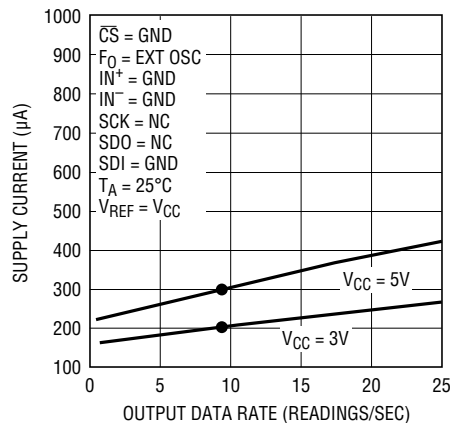

241418 G26

Sleep Mode Current vs Temperature

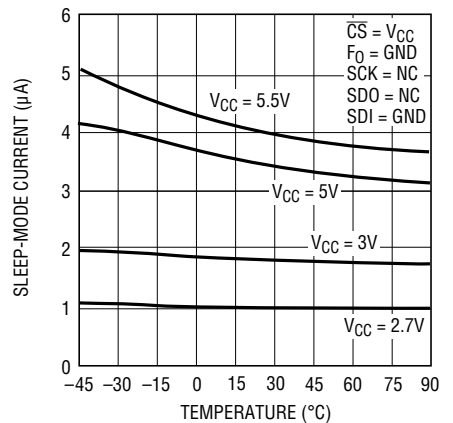

241418 G27

PIN FUNCTIONS

CH0 to CH15 (Pin 21 to Pin 28 and Pin 1 to Pin 8): Analog Inputs. May be programmed for single-ended or differential mode. CH8 to CH15 (Pin 1 to Pin 8) not connected on the LTC2414.

V_{CC} (Pin 9): Positive Supply Voltage. Bypass to GND (Pin 15) with a 10 μ F tantalum capacitor in parallel with 0.1 μ F ceramic capacitor as close to the part as possible.

COM (Pin 10): The common negative input (IN⁻) for all single-ended multiplexer configurations. The voltage on Channel 0 to 15 and COM input pins can have any value between GND – 0.3V and V_{CC} + 0.3V. Within these limits, the two selected inputs (IN⁺ and IN⁻) provide a bipolar input range ($V_{IN} = IN^+ - IN^-$) from $-0.5 \cdot V_{REF}$ to $0.5 \cdot V_{REF}$. Outside this input range, the converter produces unique overrange and underrange output codes.

REF⁺ (Pin 11), REF⁻ (Pin 12): Differential Reference Input. The voltage on these pins can have any value between GND and V_{CC} as long as the positive reference input, REF⁺, is maintained more positive than the negative reference input, REF⁻, by at least 0.1V.

GND (Pin 15): Ground. Connect this pin to a ground plane through a low impedance connection.

\overline{CS} (Pin 16): Active LOW Digital Input. A LOW on this pin enables the SDO digital output and wakes up the ADC. Following each conversion the ADC automatically enters the Sleep mode and remains in this low power state as long as \overline{CS} is HIGH. A LOW-to-HIGH transition on \overline{CS} during the Data Output transfer aborts the data transfer and starts a new conversion.

SDO (Pin 17): Three-State Digital Output. During the Data Output period, this pin is used as the serial data output. When the chip select \overline{CS} is HIGH ($\overline{CS} = V_{CC}$), the SDO pin

is in a high impedance state. During the Conversion and Sleep periods, this pin is used as the conversion status output. The conversion status can be observed by pulling \overline{CS} LOW.

SCK (Pin 18): Bidirectional Digital Clock Pin. In Internal Serial Clock Operation mode, SCK is used as the digital output for the internal serial interface clock during the Data Output period. In External Serial Clock Operation mode, SCK is used as the digital input for the external serial interface clock during the Data Output period. A weak internal pull-up is automatically activated in Internal Serial Clock Operation mode. The Serial Clock Operation mode is determined by the logic level applied to the SCK pin at power up or during the most recent falling edge of \overline{CS} .

F₀ (Pin 19): Frequency Control Pin. Digital input that controls the ADC's notch frequencies and conversion time. When the F₀ pin is connected to V_{CC} (F₀ = V_{CC}), the converter uses its internal oscillator and the digital filter first null is located at 50Hz. When the F₀ pin is connected to GND (F₀ = 0V), the converter uses its internal oscillator and the digital filter first null is located at 60Hz. When F₀ is driven by an external clock signal with a frequency f_{EOSC}, the converters use this signal as their system clock and the digital filter first null is located at a frequency f_{EOSC}/2560.

SDI (Pin 20): Serial Digital Data Input. During the Data Output period, this pin is used to shift in the multiplexer address started from the first rising SCK edge. During the Conversion and Sleep periods, this pin is in the DON'T CARE state. However, a HIGH or LOW logic level should be maintained on SDI in the DON'T CARE mode to avoid an excessive current in the SDI input buffers.

NC Pins: Do Not Connect.

FUNCTIONAL BLOCK DIAGRAM

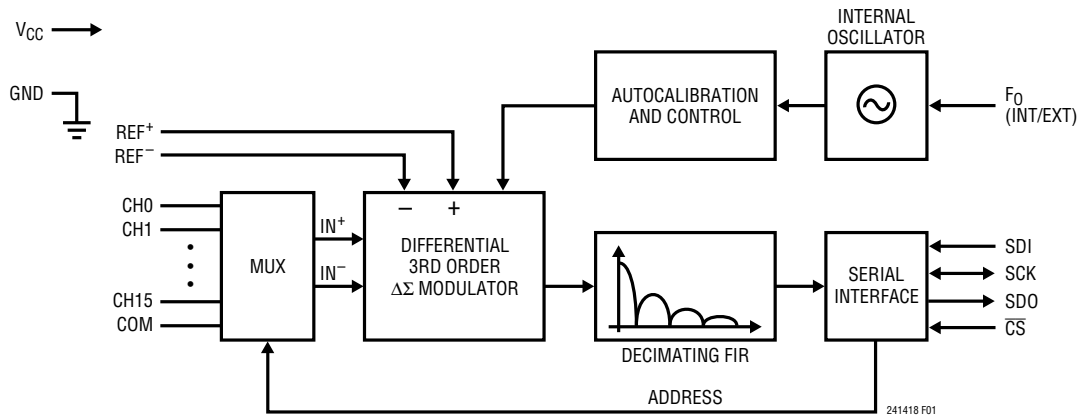
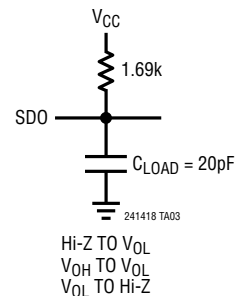
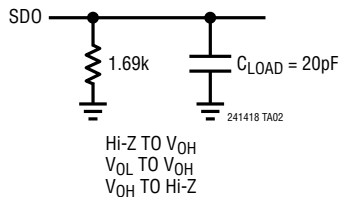

Figure 1

TEST CIRCUIT



APPLICATIONS INFORMATION

CONVERTER OPERATION

Converter Operation Cycle

The LTC2414/LTC2418 are multichannel, low power, delta-sigma analog-to-digital converters with an easy-to-use 4-wire serial interface (see Figure 1). Their operation is made up of three states. The converter operating cycle begins with the conversion, followed by the low power sleep state and ends with the data input/output (see Figure 2). The 4-wire interface consists of serial data input (SDI), serial data output (SDO), serial clock (SCK) and chip select (\overline{CS}).

Initially, the LTC2414 or LTC2418 performs a conversion. Once the conversion is complete, the device enters the sleep state. The part remains in the sleep state as long as

\overline{CS} is HIGH. While in the sleep state, power consumption is reduced by nearly two orders of magnitude. The conversion result is held indefinitely in a static shift register while the converter is in the sleep state.

Once \overline{CS} is pulled LOW, the device exits the low power mode and enters the data output state. If \overline{CS} is pulled HIGH before the first rising edge of SCK, the device returns to the low power sleep mode and the conversion result is still held in the internal static shift register. If \overline{CS} remains LOW after the first rising edge of SCK, the device begins outputting the conversion result and inputting channel selection bits. Taking \overline{CS} high at this point will terminate the data output state and start a new conversion. The channel selection control bits are shifted in through SDI from the first rising edge of SCK and depending on the

241418fb

APPLICATIONS INFORMATION

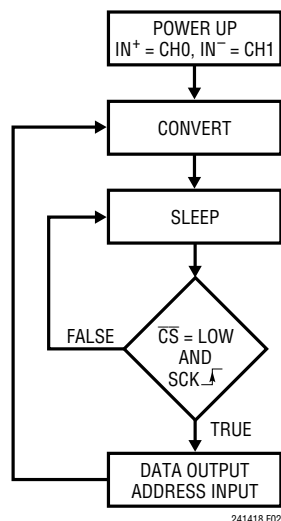

Figure 2. LTC2414/LTC2418 State Transition Diagram

control bits, the converter updates its channel selection immediately and is valid for the next conversion. The details of channel selection control bits are described in the Input Data Mode section. The output data is shifted out the SDO pin under the control of the serial clock (SCK). The output data is updated on the falling edge of SCK allowing the user to reliably latch data on the rising edge of SCK (see Figure 3). The data output state is concluded once 32 bits are read out of the ADC or when \overline{CS} is brought HIGH. The device automatically initiates a new conversion and the cycle repeats.

Through timing control of the \overline{CS} and SCK pins, the LTC2414/LTC2418 offer several flexible modes of operation (internal or external SCK and free-running conversion modes). These various modes do not require programming configuration registers; moreover, they do not disturb the cyclic operation described above. These modes of operation are described in detail in the Serial Interface Timing Modes section.

Conversion Clock

A major advantage the delta-sigma converter offers over conventional type converters is an on-chip digital filter (commonly implemented as a Sinc or Comb filter). For high resolution, low frequency applications, this filter is typically designed to reject line frequencies of 50Hz or 60Hz

plus their harmonics. The filter rejection performance is directly related to the accuracy of the converter system clock. The LTC2414/LTC2418 incorporate a highly accurate on-chip oscillator. This eliminates the need for external frequency setting components such as crystals or oscillators. Clocked by the on-chip oscillator, the LTC2414/LTC2418 achieve a minimum of 110dB rejection at the line frequency (50Hz or 60Hz $\pm 2\%$).

Ease of Use

The LTC2414/LTC2418 data output has no latency, filter settling delay or redundant data associated with the conversion cycle. There is a one-to-one correspondence between the conversion and the output data. Therefore, multiplexing multiple analog voltages is easy.

The LTC2414/LTC2418 perform offset and full-scale calibrations in every conversion cycle. This calibration is transparent to the user and has no effect on the cyclic operation described above. The advantage of continuous calibration is extreme stability of offset and full-scale readings with respect to time, supply voltage change and temperature drift.

Power-Up Sequence

The LTC2414/LTC2418 automatically enter an internal reset state when the power supply voltage V_{CC} drops below approximately 2V. This feature guarantees the integrity of the conversion result and of the serial interface mode selection. (See the 3-wire I/O sections in the Serial Interface Timing Modes section.)

When the V_{CC} voltage rises above this critical threshold, the converter creates an internal power-on-reset (POR) signal with a typical duration of 1ms. The POR signal clears all internal registers. Following the POR signal, the LTC2414/LTC2418 start a normal conversion cycle and follow the succession of states described above. The first conversion result following POR is accurate within the specifications of the device if the power supply voltage is restored within the operating range (2.7V to 5.5V) before the end of the POR time interval.

Reference Voltage Range

The LTC2414/LTC2418 accept a truly differential external reference voltage. The absolute/common mode voltage

241418fb

APPLICATIONS INFORMATION

specification for the REF⁺ and REF⁻ pins covers the entire range from GND to V_{CC}. For correct converter operation, the REF⁺ pin must always be more positive than the REF⁻ pin.

The LTC2414/LTC2418 can accept a differential reference voltage from 0.1V to V_{CC}. The converter output noise is determined by the thermal noise of the front-end circuits, and, as such, its value in nanovolts is nearly constant with reference voltage. A decrease in reference voltage will not significantly improve the converter's effective resolution. On the other hand, a reduced reference voltage will improve the converter's overall INL performance. A reduced reference voltage will also improve the converter performance when operated with an external conversion clock (external F_O signal) at substantially higher output data rates.

Input Voltage Range

The two selected pins are labeled IN⁺ and IN⁻ (see Tables 1 and 2). Once selected (either differential or single-ended multiplexing mode), the analog input is differential with a common mode range for the IN⁺ and IN⁻ input pins extending from GND - 0.3V to V_{CC} + 0.3V. Outside these limits, the ESD protection devices begin to turn on and the errors due to input leakage current increase rapidly. Within these limits, the LTC2414/LTC2418 convert the bipolar differential input signal, V_{IN} = IN⁺ - IN⁻, from -FS = -0.5 • V_{REF} to +FS = 0.5 • V_{REF} where V_{REF} = REF⁺ - REF⁻. Outside this range the converters indicate the overrange or the underrange condition using distinct output codes.

Input signals applied to IN⁺ and IN⁻ pins may extend 300mV below ground or above V_{CC}. In order to limit any fault current, resistors of up to 5k may be added in series with the IN⁺ or IN⁻ pins without affecting the performance of the device. In the physical layout, it is important to maintain the parasitic capacitance of the connection between these series resistors and the corresponding pins as low as possible; therefore, the resistors should be located as close as practical to the pins. In addition, series resistors will introduce a temperature dependent offset error due to the input leakage current.

A 1nA input leakage current will develop a 1ppm offset error on a 5k resistor if V_{REF} = 5V. This error has a very strong temperature dependency.

Input Data Format

When the LTC2414/LTC2418 are powered up, the default selection used for the first conversion is IN⁺ = CH0 and IN⁻ = CH1 (Address = 00000). In the data input/output mode following the first conversion, a channel selection can be updated using an 8-bit word. The LTC2414/LTC2418 serial input data is clocked into the SDI pin on the rising edge of SCK (see Figure 3). The input is composed of an 8-bit word with the first 3 bits acting as control bits and the remaining 5 bits as the channel address bits.

The first 2 bits are always 10 for proper updating operation. The third bit is EN. For EN = 1, the following 5 bits are used to update the input channel selection. For EN = 0, previous channel selection is kept and the following bits are ignored. Therefore, the address is updated when the 3 control bits are 101 and kept for 100. Alternatively, the 3 control bits can be all zero to keep the previous address. This alternation is intended to simplify the SDI interface allowing the user to simply connect SDI to ground if no update is needed. Combinations other than 101, 100 and 000 of the 3 control bits should be avoided.

When update operation is set (101), the following 5 bits are the channel address. The first bit, SGL, decides if the differential selection mode (SGL = 0) or the single-ended selection mode is used (SGL = 1). For SGL = 0, two adjacent channels can be selected to form a differential input; for SGL = 1, one of the 8 channels (CH0-CH7) for the LTC2414 or one of the 16 channels (CH0-CH15) for the LTC2418 is selected as the positive input and the COM pin is used as the negative input. For the LTC2414, the lower half channels (CH0-CH7) are used and the channel address bit A2 should be always 0, see Table 1. While for the LTC2418, all the 16 channels are used and the size of the corresponding selection table (Table 2) is doubled from that of the LTC2414 (Table 1). For a given channel selection, the converter will measure the voltage between the two channels indicated by IN⁺ and IN⁻ in the selected row of Tables 1 or 2.

APPLICATIONS INFORMATION

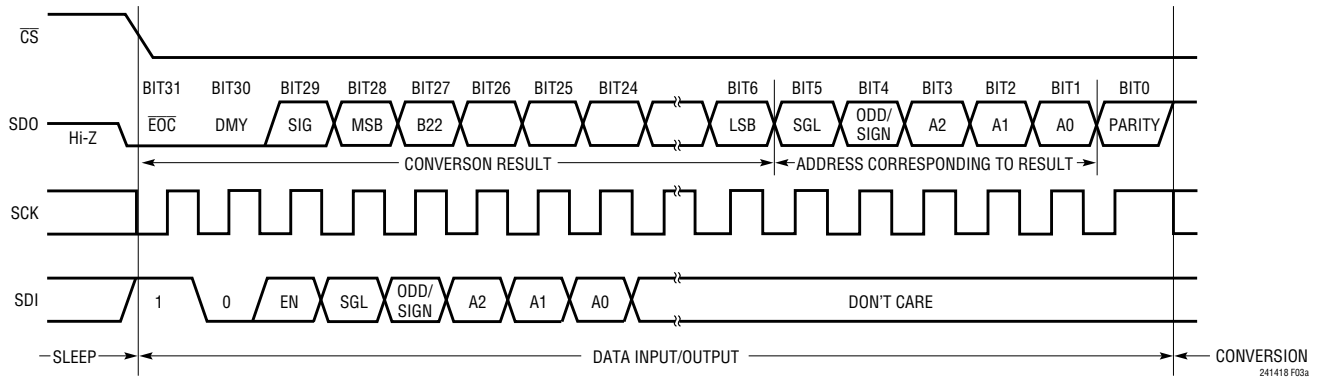

Figure 3a. Input/Output Data Timing

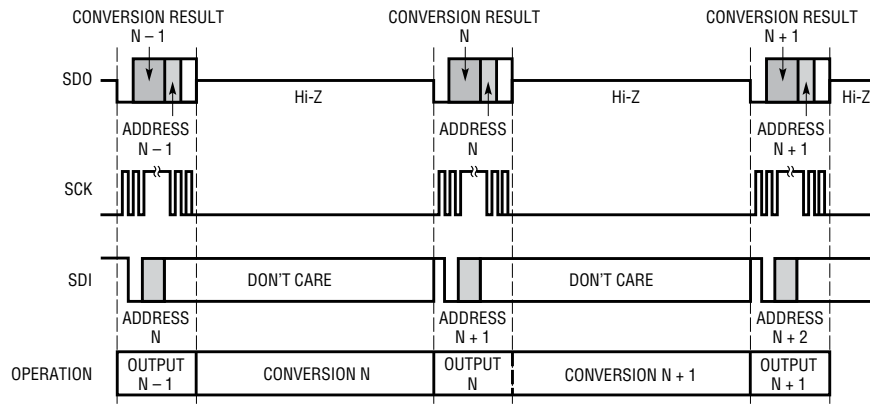

Figure 3b. Typical Operation Sequence

Table 1. Channel Selection for the LTC2414 (Bit A2 Should Always Be 0)

MUX ADDRESS				CHANNEL SELECTION									
SGL	ODD/SIGN	A2	A1	A0	0	1	2	3	4	5	6	7	COM
* 0	0	0	0	0	IN ⁺	IN ⁻							
0	0	0	0	1			IN ⁺	IN ⁻					
0	0	0	1	0					IN ⁺	IN ⁻			
0	0	0	1	1							IN ⁺	IN ⁻	
0	1	0	0	0	IN ⁻	IN ⁺							
0	1	0	0	1			IN ⁻	IN ⁺					
0	1	0	1	0					IN ⁻	IN ⁺			
0	1	0	1	1							IN ⁻	IN ⁺	
1	0	0	0	0	IN ⁺								IN ⁻
1	0	0	0	1			IN ⁺						IN ⁻
1	0	0	1	0					IN ⁺				IN ⁻
1	0	0	1	1							IN ⁺		IN ⁻
1	1	0	0	0		IN ⁺							IN ⁻
1	1	0	0	1				IN ⁺					IN ⁻
1	1	0	1	0						IN ⁺			IN ⁻
1	1	0	1	1								IN ⁺	IN ⁻

*Default at power up

APPLICATIONS INFORMATION

Table 2. Channel Selection for the LTC2418

MUX ADDRESS					CHANNEL SELECTION																	
SGL	ODD/ SIGN	A2	A1	A0	0	1	2	3	4	5	6	7	8	9	10	11	12	13	14	15	COM	
*0	0	0	0	0	IN ⁺	IN ⁻																
0	0	0	0	1			IN ⁺	IN ⁻														
0	0	0	1	0					IN ⁺	IN ⁻												
0	0	0	1	1							IN ⁺	IN ⁻										
0	0	1	0	0									IN ⁺	IN ⁻								
0	0	1	0	1											IN ⁺	IN ⁻						
0	0	1	1	0													IN ⁺	IN ⁻				
0	0	1	1	1															IN ⁺	IN ⁻		
0	1	0	0	0	IN ⁻	IN ⁺																
0	1	0	0	1			IN ⁻	IN ⁺														
0	1	0	1	0					IN ⁻	IN ⁺												
0	1	0	1	1							IN ⁻	IN ⁺										
0	1	1	0	0									IN ⁻	IN ⁺								
0	1	1	0	1											IN ⁻	IN ⁺						
0	1	1	1	0													IN ⁻	IN ⁺				
0	1	1	1	1															IN ⁻	IN ⁺		
1	0	0	0	0	IN ⁺																	IN ⁻
1	0	0	0	1			IN ⁺															IN ⁻
1	0	0	1	0					IN ⁺													IN ⁻
1	0	0	1	1						IN ⁺												IN ⁻
1	0	1	0	0								IN ⁺										IN ⁻
1	0	1	0	1										IN ⁺								IN ⁻
1	0	1	1	0												IN ⁺						IN ⁻
1	0	1	1	1													IN ⁺					IN ⁻
1	1	0	0	0		IN ⁺																IN ⁻
1	1	0	0	1				IN ⁺														IN ⁻
1	1	0	1	0					IN ⁺													IN ⁻
1	1	0	1	1						IN ⁺												IN ⁻
1	1	1	0	0									IN ⁺									IN ⁻
1	1	1	0	1											IN ⁺							IN ⁻
1	1	1	1	0													IN ⁺					IN ⁻
1	1	1	1	1																IN ⁺		IN ⁻

*Default at power up

Output Data Format

The LTC2414/LTC2418 serial output data stream is 32 bits long. The first 3 bits represent status information indicating the sign and conversion state. The next 23 bits are the conversion result, MSB first. The next 5 bits (Bit 5 to Bit 1)

indicate which channel the conversion just performed was selected. The address bits programmed during this data output phase select the input channel for the next conversion cycle. These address bits are output during the subsequent data read, as shown in Figure 3b. The last

APPLICATIONS INFORMATION

bit is a parity bit representing the parity of the previous 31 bits. The parity bit is useful to check the output data integrity especially when the output data is transmitted over a distance. The third and fourth bits together are also used to indicate an underrange condition (the differential input voltage is below $-FS$) or an overrange condition (the differential input voltage is above $+FS$).

Bit 31 (first output bit) is the end of conversion (\overline{EOC}) indicator. This bit is available at the SDO pin during the conversion and sleep states whenever the \overline{CS} pin is LOW. This bit is HIGH during the conversion and goes LOW when the conversion is complete.

Bit 30 (second output bit) is a dummy bit (DMY) and is always LOW.

Bit 29 (third output bit) is the conversion result sign indicator (SIG). If V_{IN} is >0 , this bit is HIGH. If V_{IN} is <0 , this bit is LOW.

Bit 28 (fourth output bit) is the most significant bit (MSB) of the result. This bit in conjunction with Bit 29 also provides the underrange or overrange indication. If both Bit 29 and Bit 28 are HIGH, the differential input voltage is above $+FS$. If both Bit 29 and Bit 28 are LOW, the differential input voltage is below $-FS$.

The function of these bits is summarized in Table 3.

Table 3. LTC2414/LTC2418 Status Bits

Input Range	BIT 31 \overline{EOC}	BIT 30 DMY	BIT 29 SIG	BIT 28 MSB
$V_{IN} \geq 0.5 \cdot V_{REF}$	0	0	1	1
$0V \leq V_{IN} < 0.5 \cdot V_{REF}$	0	0	1	0
$-0.5 \cdot V_{REF} \leq V_{IN} < 0V$	0	0	0	1
$V_{IN} < -0.5 \cdot V_{REF}$	0	0	0	0

Bits 28-6 are the 23-bit conversion result MSB first.

Bit 6 is the least significant bit (LSB).

Bits 5-1 are the corresponding channel selection bits for the present conversion result with bit SGL output first as shown in Figure 3.

Bit 0 is the parity bit representing the parity of the previous 31 bits. Including the parity bit, the total numbers of 1's and 0's in the output data are always even.

Data is shifted out of the SDO pin under control of the serial clock (SCK), see Figure 3. Whenever \overline{CS} is HIGH, SDO remains high impedance and any externally generated SCK clock pulses are ignored by the internal data out shift register.

In order to shift the conversion result out of the device, \overline{CS} must first be driven LOW. \overline{EOC} is seen at the SDO pin of the device once \overline{CS} is pulled LOW. \overline{EOC} changes real time from HIGH to LOW at the completion of a conversion. This signal may be used as an interrupt for an external microcontroller. Bit 31 (\overline{EOC}) can be captured on the first rising edge of SCK. Bit 30 is shifted out of the device on the first falling edge of SCK. The final data bit (Bit 0) is shifted out on the falling edge of the 31st SCK and may be latched on the rising edge of the 32nd SCK pulse. On the falling edge of the 32nd SCK pulse, SDO goes HIGH indicating the initiation of a new conversion cycle. This bit serves as \overline{EOC} (Bit 31) for the next conversion cycle. Table 4 summarizes the output data format.

As long as the voltage applied to any channel (CH0-CH15, COM) is maintained within the $-0.3V$ to $(V_{CC} + 0.3V)$ absolute maximum operating range, a conversion result is generated for any differential input voltage V_{IN} from $-FS = -0.5 \cdot V_{REF}$ to $+FS = 0.5 \cdot V_{REF}$. For differential input voltages greater than $+FS$, the conversion result is clamped to the value corresponding to the $+FS + 1LSB$. For differential input voltages below $-FS$, the conversion result is clamped to the value corresponding to $-FS - 1LSB$.

Frequency Rejection Selection (F_0)

The LTC2414/LTC2418 internal oscillator provides better than 110dB normal mode rejection at the line frequency and all its harmonics for 50Hz $\pm 2\%$ or 60Hz $\pm 2\%$. For 60Hz rejection, F_0 should be connected to GND while for 50Hz rejection the F_0 pin should be connected to V_{CC} .

The selection of 50Hz or 60Hz rejection can also be made by driving F_0 to an appropriate logic level. A selection change during the sleep or data output states will not disturb the converter operation. If the selection is made during the conversion state, the result of the conversion in progress may be outside specifications but the following conversions will not be affected.

APPLICATIONS INFORMATION

Table 4. LTC2414/LTC2418 Output Data Format

Differential Input Voltage V_{IN}^*	Bit 31 EOC	Bit 30 DMY	Bit 29 SIG	Bit 28 MSB	Bit 27	Bit 26	Bit 25	...	Bit 6 LSB
$V_{IN}^* \geq 0.5 \cdot V_{REF}^{**}$	0	0	1	1	0	0	0	...	0
$0.5 \cdot V_{REF}^{**} - 1\text{LSB}$	0	0	1	0	1	1	1	...	1
$0.25 \cdot V_{REF}^{**}$	0	0	1	0	1	0	0	...	0
$0.25 \cdot V_{REF}^{**} - 1\text{LSB}$	0	0	1	0	0	1	1	...	1
0	0	0	1	0	0	0	0	...	0
-1LSB	0	0	0	1	1	1	1	...	1
$-0.25 \cdot V_{REF}^{**}$	0	0	0	1	1	0	0	...	0
$-0.25 \cdot V_{REF}^{**} - 1\text{LSB}$	0	0	0	1	0	1	1	...	1
$-0.5 \cdot V_{REF}^{**}$	0	0	0	1	0	0	0	...	0
$V_{IN}^* < -0.5 \cdot V_{REF}^{**}$	0	0	0	0	1	1	1	...	1

*The differential input voltage $V_{IN} = IN^+ - IN^-$.

**The differential reference voltage $V_{REF} = REF^+ - REF^-$.

When a fundamental rejection frequency different from 50Hz or 60Hz is required or when the converter must be synchronized with an outside source, the LTC2414/LTC2418 can operate with an external conversion clock. The converter automatically detects the presence of an external clock signal at the F_0 pin and turns off the internal oscillator. The frequency f_{EOSC} of the external signal must be at least 2560Hz (1Hz notch frequency) to be detected. The external clock signal duty cycle is not significant as long as the minimum and maximum specifications for the high and low periods t_{HE0} and t_{LE0} are observed.

While operating with an external conversion clock of a frequency f_{EOSC} , the converter provides better than 110dB normal mode rejection in a frequency range $f_{EOSC}/2560 \pm 4\%$ and its harmonics. The normal mode rejection as a function of the input frequency deviation from $f_{EOSC}/2560$ is shown in Figure 4.

Whenever an external clock is not present at the F_0 pin, the converter automatically activates its internal oscillator and enters the Internal Conversion Clock mode. The converter operation will not be disturbed if the change of conversion clock source occurs during the sleep state or during the data output state while the converter uses an external serial clock. If the change occurs during the conversion state, the result of the conversion in progress may be outside specifications but the following conversions will not be affected. If the change occurs during the data output state and the converter is in the Internal SCK

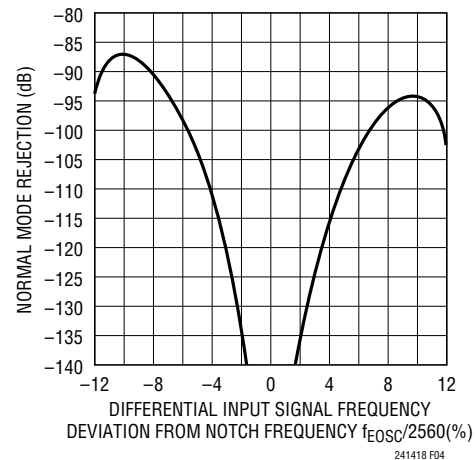

Figure 4. LTC2414/LTC2418 Normal Mode Rejection When Using an External Oscillator of Frequency f_{EOSC}

mode, the serial clock duty cycle may be affected but the serial data stream will remain valid.

Table 5 summarizes the duration of each state and the achievable output data rate as a function of F_0 .

SERIAL INTERFACE PINS

The LTC2414/LTC2418 transmit the conversion results and receive the start of conversion command through a synchronous 4-wire interface. During the conversion and sleep states, this interface can be used to assess the converter status and during the data I/O state it is used to read the conversion result and write in channel selection bits.

APPLICATIONS INFORMATION

Table 5. LTC2414/LTC2418 State Duration

State	Operating Mode		Duration
CONVERT	Internal Oscillator	$F_0 = \text{LOW}$ (60Hz Rejection)	133ms, Output Data Rate ≤ 7.5 Readings/s
		$F_0 = \text{HIGH}$ (50Hz Rejection)	160ms, Output Data Rate ≤ 6.2 Readings/s
	External Oscillator	$F_0 = \text{External Oscillator}$ with Frequency f_{EOSC} kHz ($f_{\text{EOSC}}/2560$ Rejection)	$20510/f_{\text{EOSC}}$ s, Output Data Rate $\leq f_{\text{EOSC}}/20510$ Readings/s
SLEEP			As Long As $\overline{\text{CS}} = \text{HIGH}$ Until $\overline{\text{CS}} = \text{LOW}$ and $\text{SCK} \downarrow$
DATA OUTPUT	Internal Serial Clock	$F_0 = \text{LOW/HIGH}$ (Internal Oscillator)	As Long As $\overline{\text{CS}} = \text{LOW}$ But Not Longer Than 1.67ms (32 SCK cycles)
		$F_0 = \text{External Oscillator}$ with Frequency f_{EOSC} kHz	As Long As $\overline{\text{CS}} = \text{LOW}$ But Not Longer Than $256/f_{\text{EOSC}}$ ms (32 SCK cycles)
	External Serial Clock with Frequency f_{SCK} kHz	As Long As $\overline{\text{CS}} = \text{LOW}$ But Not Longer Than $32/f_{\text{SCK}}$ ms (32 SCK cycles)	

Serial Clock Input/Output (SCK)

The serial clock signal present on SCK (Pin 18) is used to synchronize the data transfer. Each bit of data is shifted out the SDO pin on the falling edge of the serial clock and each input bit is shifted in the SDI pin on the rising edge of the serial clock.

In the Internal SCK mode of operation, the SCK pin is an output and the LTC2414/LTC2418 create their own serial clock by dividing the internal conversion clock by 8. In the External SCK mode of operation, the SCK pin is used as input. The internal or external SCK mode is selected on power-up and then reselected every time a HIGH-to-LOW transition is detected at the $\overline{\text{CS}}$ pin. If SCK is HIGH or floating at power-up or during this transition, the converter enters the internal SCK mode. If SCK is LOW at power-up or during this transition, the converter enters the external SCK mode.

Serial Data Input (SDI)

The serial data input pin, SDI (Pin 20), is used to shift in the channel control bits during the data output state to prepare the channel selection for the following conversion.

When $\overline{\text{CS}}$ (Pin 16) is HIGH or the converter is in the conversion state, the SDI input is ignored and may be driven HIGH or LOW. When $\overline{\text{CS}}$ goes LOW and the conversion is complete, SDO goes low and then SDI starts to shift in bits on the rising edge of SCK.

Serial Data Output (SDO)

The serial data output pin, SDO (Pin 17), provides the result of the last conversion as a serial bit stream (MSB first) during the data output state. In addition, the SDO pin is used as an end of conversion indicator during the conversion and sleep states.

When $\overline{\text{CS}}$ (Pin 16) is HIGH, the SDO driver is switched to a high impedance state. This allows sharing the serial interface with other devices. If $\overline{\text{CS}}$ is LOW during the convert or sleep state, SDO will output $\overline{\text{EOC}}$. If $\overline{\text{CS}}$ is LOW during the conversion phase, the $\overline{\text{EOC}}$ bit appears HIGH on the SDO pin. Once the conversion is complete, $\overline{\text{EOC}}$ goes LOW. The device remains in the sleep state until the first rising edge of SCK occurs while $\overline{\text{CS}} = \text{LOW}$.

Chip Select Input ($\overline{\text{CS}}$)

The active LOW chip select, $\overline{\text{CS}}$ (Pin 16), is used to test the conversion status and to enable the data input/output transfer as described in the previous sections.

In addition, the $\overline{\text{CS}}$ signal can be used to trigger a new conversion cycle before the entire serial data transfer has been completed. The LTC2414/LTC2418 will abort any serial data transfer in progress and start a new conversion cycle anytime a LOW-to-HIGH transition is detected at the $\overline{\text{CS}}$ pin after the converter has entered the data input/output state (i.e., after the first rising edge of SCK occurs with $\overline{\text{CS}} = \text{LOW}$). If the device has not finished loading

241418fb

APPLICATIONS INFORMATION

the last input bit A0 of SDI by the time \overline{CS} pulled HIGH, the address information is discarded and the previous address is kept.

Finally, \overline{CS} can be used to control the free-running modes of operation, see Serial Interface Timing Modes section. Grounding \overline{CS} will force the ADC to continuously convert at the maximum output rate selected by F_0 .

SERIAL INTERFACE TIMING MODES

The LTC2414/LTC2418's 4-wire interface is SPI and MICROWIRE compatible. This interface offers several flexible modes of operation. These include internal/external

serial clock, 3- or 4-wire I/O, single cycle conversion. The following sections describe each of these serial interface timing modes in detail. In all these cases, the converter can use the internal oscillator ($F_0 = \text{LOW}$ or $F_0 = \text{HIGH}$) or an external oscillator connected to the F_0 pin. Refer to Table 6 for a summary.

External Serial Clock, Single Cycle Operation (SPI/MICROWIRE Compatible)

This timing mode uses an external serial clock to shift out the conversion result and a \overline{CS} signal to monitor and control the state of the conversion cycle, see Figure 5.

Table 6. LTC2414/LTC2418 Interface Timing Modes

Configuration	SCK Source	Conversion Cycle Control	Data Output Control	Connection and Waveforms
External SCK, Single Cycle Conversion	External	\overline{CS} and SCK	\overline{CS} and SCK	Figures 5, 6
External SCK, 3-Wire I/O	External	SCK	SCK	Figure 7
Internal SCK, Single Cycle Conversion	Internal	$\overline{CS} \downarrow$	$\overline{CS} \downarrow$	Figures 8, 9
Internal SCK, 3-Wire I/O, Continuous Conversion	Internal	Continuous	Internal	Figure 10

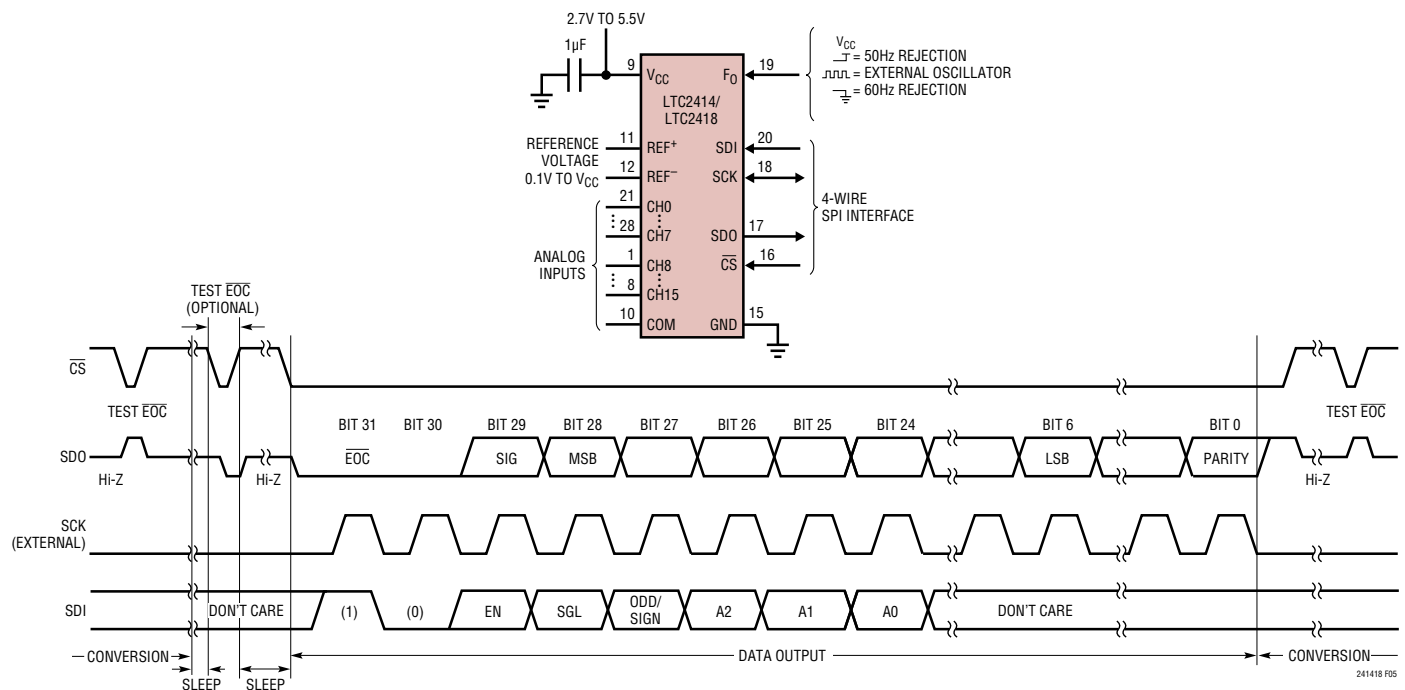

Figure 5. External Serial Clock, Single Cycle Operation

APPLICATIONS INFORMATION

The serial clock mode is selected on the falling edge of \overline{CS} . To select the external serial clock mode, the serial clock pin (SCK) must be LOW during each \overline{CS} falling edge.

The serial data output pin (SDO) is Hi-Z as long as \overline{CS} is HIGH. At any time during the conversion cycle, \overline{CS} may be pulled LOW in order to monitor the state of the converter. While \overline{CS} is pulled LOW, \overline{EOC} is output to the SDO pin. $\overline{EOC} = 1$ while a conversion is in progress and $\overline{EOC} = 0$ if the device is in the sleep state. Independent of \overline{CS} , the device automatically enters the low power sleep state once the conversion is complete.

When the device is in the sleep state, its conversion result is held in an internal static shift register. The device remains in the sleep state until the first rising edge of SCK is seen while \overline{CS} is LOW. The input data is then shifted in via the SDI pin on the rising edge of SCK (including the first rising edge) and the output data is shifted out of the SDO pin on each falling edge of SCK. This enables external circuitry to latch the output on the rising edge of SCK. \overline{EOC} can be latched on the first rising edge of SCK

and the last bit of the conversion result can be latched on the 32nd rising edge of SCK. On the 32nd falling edge of SCK, the device begins a new conversion. SDO goes HIGH ($\overline{EOC} = 1$) indicating a conversion is in progress.

At the conclusion of the data cycle, \overline{CS} may remain LOW and \overline{EOC} monitored as an end-of-conversion interrupt. Alternatively, \overline{CS} may be driven HIGH setting SDO to Hi-Z. As described above, \overline{CS} may be pulled LOW at any time in order to monitor the conversion status.

Typically, \overline{CS} remains LOW during the data output state. However, the data output state may be aborted by pulling \overline{CS} HIGH anytime between the first rising edge and the 32nd falling edge of SCK, see Figure 6. On the rising edge of \overline{CS} , the device aborts the data output state and immediately initiates a new conversion. If the device has not finished loading the last input bit A0 of SDI by the time \overline{CS} is pulled HIGH, the address information is discarded and the previous address is kept. This is useful for systems not requiring all 32 bits of output data, aborting an invalid conversion cycle or synchronizing the start of a conversion.

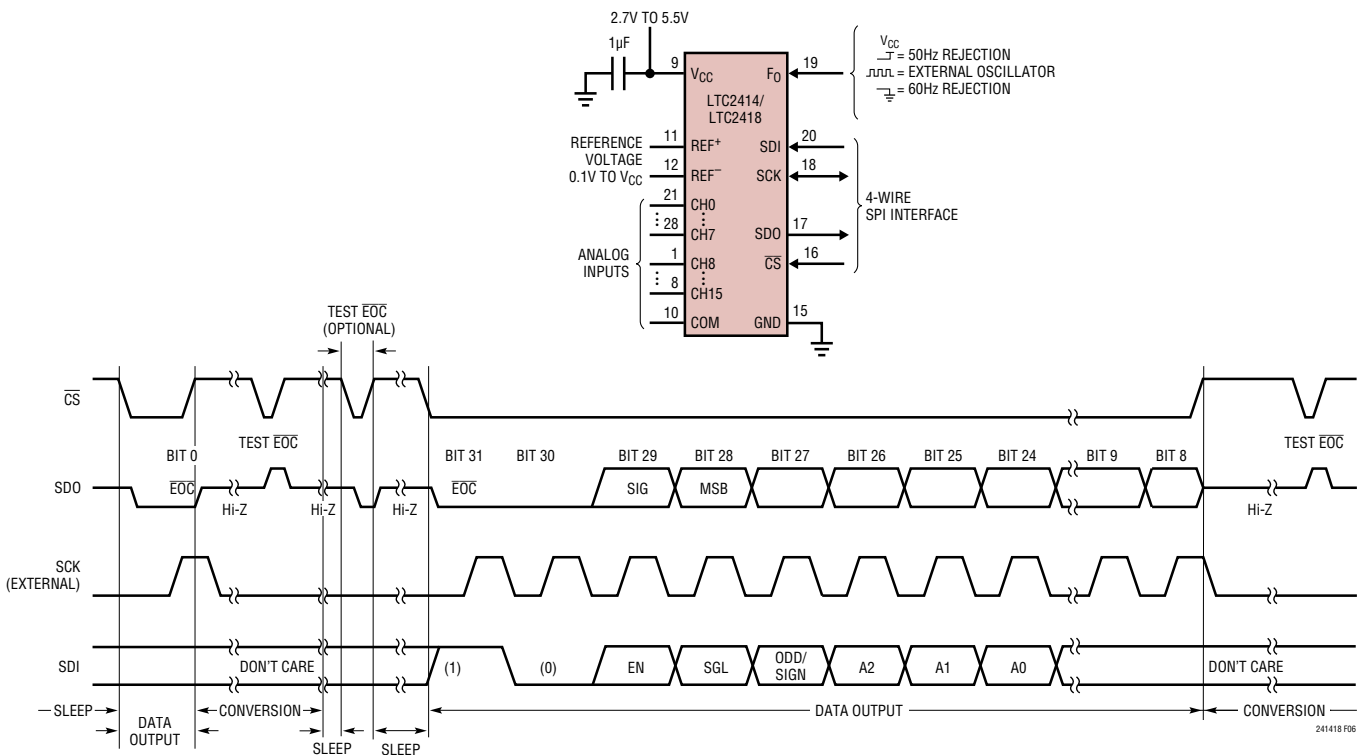

Figure 6. External Serial Clock, Reduced Data Output Length

APPLICATIONS INFORMATION

External Serial Clock, 3-Wire I/O

This timing mode utilizes a 3-wire serial I/O interface. The conversion result is shifted out of the device by an externally generated serial clock (SCK) signal, see Figure 7. \overline{CS} may be permanently tied to ground, simplifying the user interface or isolation barrier.

The external serial clock mode is selected at the end of the power-on reset (POR) cycle. The POR cycle is concluded typically 1ms after V_{CC} exceeds approximately 2V. The level applied to SCK at this time determines if SCK is internal or external. SCK must be driven LOW prior to the end of POR in order to enter the external serial clock timing mode.

Since \overline{CS} is tied LOW, the end-of-conversion (\overline{EOC}) can be continuously monitored at the SDO pin during the convert and sleep states. \overline{EOC} may be used as an interrupt to an external controller indicating the conversion result is ready. $\overline{EOC} = 1$ while the conversion is in progress and $\overline{EOC} = 0$ once the conversion ends. On the falling edge of \overline{EOC} , the conversion result is loaded into an internal static shift register. The input data is then shifted in via the SDI pin on the rising edge of SCK (including the first rising edge) and the output data is shifted out of the SDO pin on each

falling edge of SCK. EOC can be latched on the first rising edge of SCK. On the 32nd falling edge of SCK, SDO goes HIGH ($\overline{EOC} = 1$) indicating a new conversion has begun.

Internal Serial Clock, Single Cycle Operation

This timing mode uses an internal serial clock to shift out the conversion result and a \overline{CS} signal to monitor and control the state of the conversion cycle, see Figure 8.

In order to select the internal serial clock timing mode, the serial clock pin (SCK) must be floating (Hi-Z) or pulled HIGH prior to the falling edge of \overline{CS} . The device will not enter the internal serial clock mode if SCK is driven LOW on the falling edge of \overline{CS} . An internal weak pull-up resistor is active on the SCK pin during the falling edge of \overline{CS} ; therefore, the internal serial clock timing mode is automatically selected if SCK is not externally driven.

The serial data output pin (SDO) is Hi-Z as long as \overline{CS} is HIGH. At any time during the conversion cycle, \overline{CS} may be pulled LOW in order to monitor the state of the converter. Once \overline{CS} is pulled LOW, SCK goes LOW and \overline{EOC} is output to the SDO pin. $\overline{EOC} = 1$ while a conversion is in progress and $\overline{EOC} = 0$ if the device is in the sleep state.

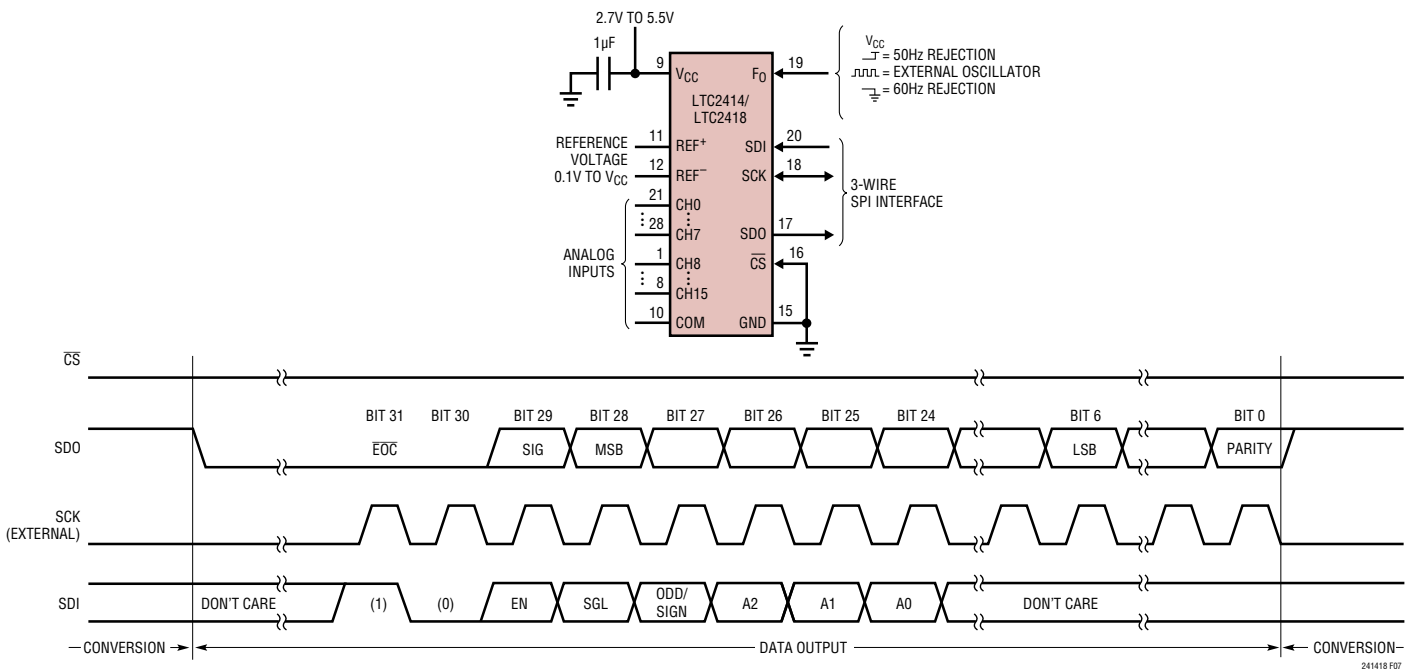

Figure 7. External Serial Clock, $\overline{CS} = 0$ Operation

APPLICATIONS INFORMATION

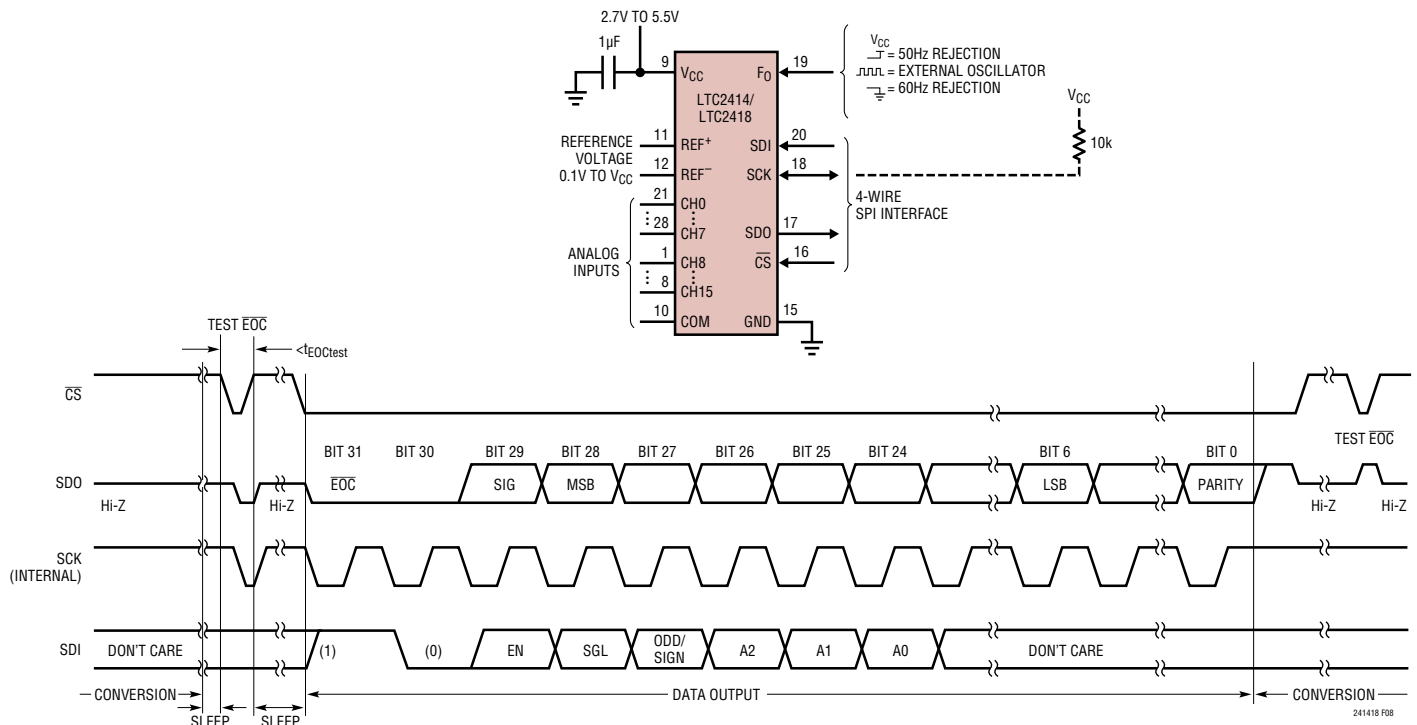

Figure 8. Internal Serial Clock, Single Cycle Operation

When testing \overline{EOC} , if the conversion is complete ($\overline{EOC} = 0$), the device will exit the low power mode during the \overline{EOC} test. In order to allow the device to return to the low power sleep state, \overline{CS} must be pulled HIGH before the first rising edge of SCK. In the internal SCK timing mode, SCK goes HIGH and the device begins outputting data at time $t_{EOCtest}$ after the falling edge of \overline{CS} (if $\overline{EOC} = 0$) or $t_{EOCtest}$ after \overline{EOC} goes LOW (if \overline{CS} is LOW during the falling edge of \overline{EOC}). The value of $t_{EOCtest}$ is $23\mu s$ if the device is using its internal oscillator ($F_0 = \text{logic LOW or HIGH}$). If F_0 is driven by an external oscillator of frequency f_{EOSC} , then $t_{EOCtest}$ is $3.6/f_{EOSC}$. If \overline{CS} is pulled HIGH before time $t_{EOCtest}$, the device returns to the sleep state and the conversion result is held in the internal static shift register.

If \overline{CS} remains LOW longer than $t_{EOCtest}$, the first rising edge of SCK will occur and the conversion result is serially shifted out of the SDO pin. The data I/O cycle concludes after the 32nd rising edge. The input data is then shifted in via the SDI pin on the rising edge of SCK (including the first rising edge) and the output data is shifted out of the SDO pin on each falling edge of SCK. The internally generated serial clock is output to the SCK pin. This signal

may be used to shift the conversion result into external circuitry. \overline{EOC} can be latched on the first rising edge of SCK and the last bit of the conversion result on the 32nd rising edge of SCK. After the 32nd rising edge, SDO goes HIGH ($\overline{EOC} = 1$), SCK stays HIGH and a new conversion starts.

Typically, \overline{CS} remains LOW during the data output state. However, the data output state may be aborted by pulling \overline{CS} HIGH anytime between the first and 32nd rising edge of SCK, see Figure 9. On the rising edge of \overline{CS} , the device aborts the data output state and immediately initiates a new conversion. If the device has not finished loading the last input bit A0 of SDI by the time \overline{CS} is pulled HIGH, the address information is discarded and the previous address is still kept. This is useful for systems not requiring all 32 bits of output data, aborting an invalid conversion cycle, or synchronizing the start of a conversion. If \overline{CS} is pulled HIGH while the converter is driving SCK LOW, the internal pull-up is not available to restore SCK to a logic HIGH state. This will cause the device to exit the internal serial clock mode on the next falling edge of \overline{CS} . This can be avoided by adding an external 10k pull-up resistor to the SCK pin or by never pulling \overline{CS} HIGH when SCK is LOW.

241418fb

APPLICATIONS INFORMATION

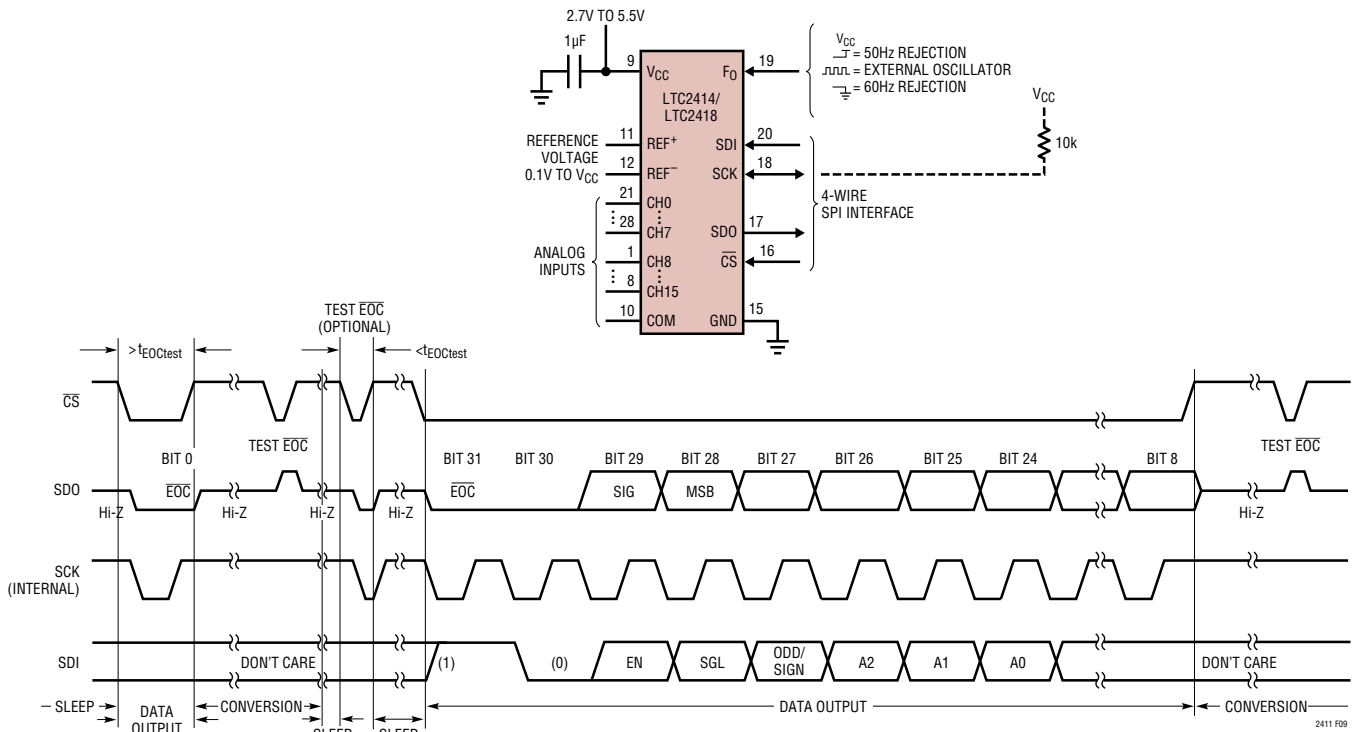

Figure 9. Internal Serial Clock, Reduced Data Output Length

Whenever SCK is LOW, the LTC2414/LTC2418's internal pull-up at pin SCK is disabled. Normally, SCK is not externally driven if the device is in the internal SCK timing mode. However, certain applications may require an external driver on SCK. If this driver goes Hi-Z after outputting a LOW signal, the LTC2414/LTC2418's internal pull-up remains disabled. Hence, SCK remains LOW. On the next falling edge of \overline{CS} , the device is switched to the external SCK timing mode. By adding an external 10k pull-up resistor to SCK, this pin goes HIGH once the external driver goes Hi-Z. On the next \overline{CS} falling edge, the device will remain in the internal SCK timing mode.

A similar situation may occur during the sleep state when \overline{CS} is pulsed HIGH-LOW-HIGH in order to test the conversion status. If the device is in the sleep state ($\overline{EOC} = 0$), SCK will go LOW. Once \overline{CS} goes HIGH (within the time period defined above as $t_{EOCtest}$), the internal pull-up is activated. For a heavy capacitive load on the SCK pin, the internal pull-up may not be adequate to return SCK to a HIGH level before \overline{CS} goes low again. This is not a concern under normal conditions where \overline{CS} remains LOW

after detecting $\overline{EOC} = 0$. This situation is easily overcome by adding an external 10k pull-up resistor to the SCK pin.

Internal Serial Clock, 3-Wire I/O, Continuous Conversion

This timing mode uses a 3-wire interface. The conversion result is shifted out of the device by an internally generated serial clock (SCK) signal, see Figure 10. \overline{CS} may be permanently tied to ground, simplifying the user interface or isolation barrier.

The internal serial clock mode is selected at the end of the power-on reset (POR) cycle. The POR cycle is concluded approximately 1ms after V_{CC} exceeds 2V. An internal weak pull-up is active during the POR cycle; therefore, the internal serial clock timing mode is automatically selected if SCK is not externally driven LOW (if SCK is loaded such that the internal pull-up cannot pull the pin HIGH, the external SCK mode will be selected).

During the conversion, the SCK and the serial data output pin (SDO) are HIGH ($\overline{EOC} = 1$). Once the conversion is

APPLICATIONS INFORMATION

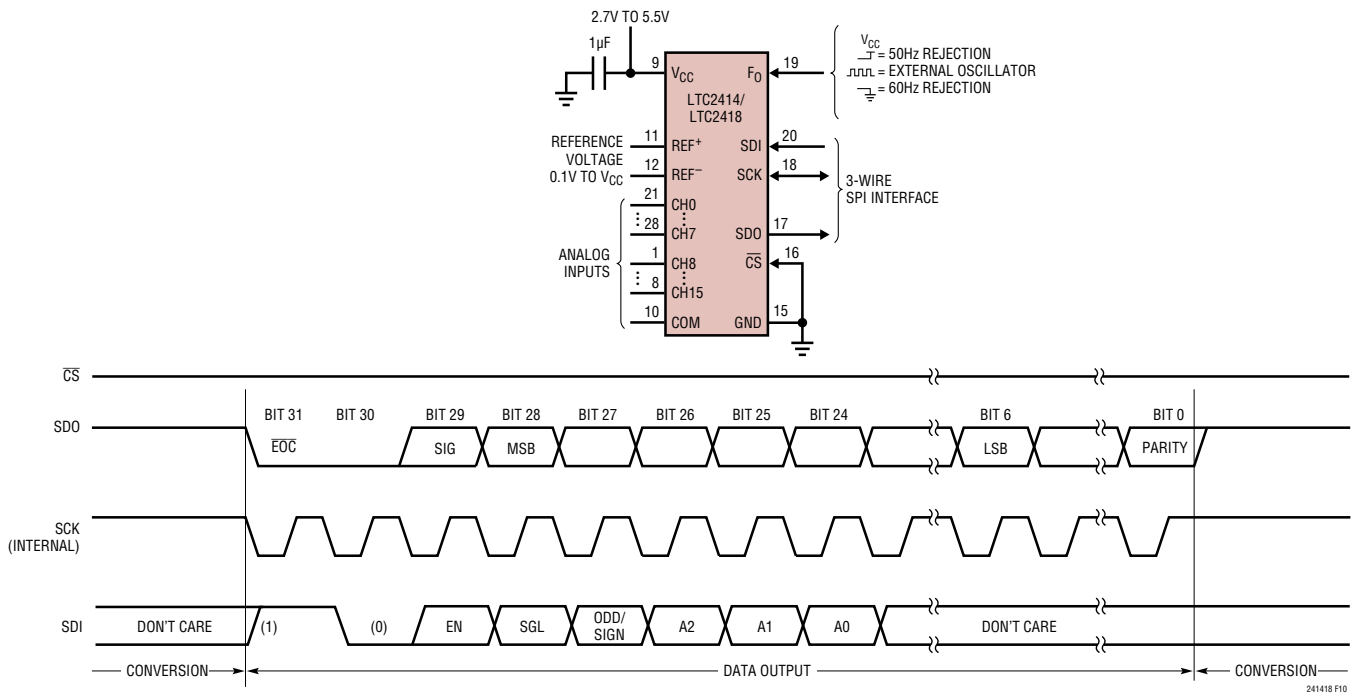

Figure 10. Internal Serial Clock, $\overline{CS} = 0$ Continuous Operation

complete, SCK and SDO go LOW ($\overline{EOC} = 0$) indicating the conversion has finished and the device has entered the low power sleep state. The part remains in the sleep state a minimum amount of time (1/2 the internal SCK period) then immediately begins outputting data. The data input/output cycle begins on the first rising edge of SCK and ends after the 32nd rising edge. The input data is then shifted in via the SDI pin on the rising edge of SCK (including the first rising edge) and the output data is shifted out of the SDO pin on each falling edge of SCK. The internally generated serial clock is output to the SCK pin. This signal may be used to shift the conversion result into external circuitry. \overline{EOC} can be latched on the first rising edge of SCK and the last bit of the conversion result can be latched on the 32nd rising edge of SCK. After the 32nd rising edge, SDO goes HIGH ($\overline{EOC} = 1$) indicating a new conversion is in progress. SCK remains HIGH during the conversion.

PRESERVING THE CONVERTER ACCURACY

The LTC2414/LTC2418 are designed to reduce as much as possible the conversion result sensitivity to device decoupling, PCB layout, antialiasing circuits, line frequency

perturbations and so on. Nevertheless, in order to preserve the extreme accuracy capability of this part, some simple precautions are desirable.

Digital Signal Levels

The LTC2414/LTC2418's digital interface is easy to use. Its digital inputs (SDI, F_0 , \overline{CS} and SCK in External SCK mode of operation) accept standard TTL/CMOS logic levels and the internal hysteresis receivers can tolerate edge rates as slow as 100µs. However, some considerations are required to take advantage of the exceptional accuracy and low supply current of this converter.

The digital output signals (SDO and SCK in Internal SCK mode of operation) are less of a concern because they are not generally active during the conversion state.

While a digital input signal is in the range 0.5V to ($V_{CC} - 0.5V$), the CMOS input receiver draws additional current from the power supply. It should be noted that, when any one of the digital input signals (SDI, F_0 , \overline{CS} and SCK in External SCK mode of operation) is within this range, the power supply current may increase even if the signal in question is at a valid logic level. For

APPLICATIONS INFORMATION

micropower operation, it is recommended to drive all digital input signals to full CMOS levels [$V_{IL} < 0.4V$ and $V_{OH} > (V_{CC} - 0.4V)$].

During the conversion period, the undershoot and/or overshoot of a fast digital signal connected to the pins may severely disturb the analog to digital conversion process. Undershoot and overshoot can occur because of the impedance mismatch at the converter pin when the transition time of an external control signal is less than twice the propagation delay from the driver to LTC2414/LTC2418. For reference, on a regular FR-4 board, signal propagation velocity is approximately 183ps/inch for internal traces and 170ps/inch for surface traces. Thus, a driver generating a control signal with a minimum transition time of 1ns must be connected to the converter pin through a trace shorter than 2.5 inches. This problem becomes particularly difficult when shared control lines are used and multiple reflections may occur. The solution is to carefully terminate all transmission lines close to their characteristic impedance.

Parallel termination near the LTC2414/LTC2418 pin will eliminate this problem but will increase the driver power dissipation. A series resistor between 27 Ω and 56 Ω placed near the driver or near the LTC2414/LTC2418 pin will also eliminate this problem without additional power dissipation. The actual resistor value depends upon the trace impedance and connection topology.

An alternate solution is to reduce the edge rate of the control signals. It should be noted that using very slow edges will increase the converter power supply current during the transition time. The differential input and reference architecture reduce substantially the converter's sensitivity to ground currents.

Particular attention must be given to the connection of the F_0 signal when the LTC2414/LTC2418 are used with an external conversion clock. This clock is active during the conversion time and the normal mode rejection provided by the internal digital filter is not very high at this frequency. A normal mode signal of this frequency at the converter reference terminals may result into DC gain and INL errors. A normal mode signal of this frequency at the converter input terminals may result into a DC offset error.

Such perturbations may occur due to asymmetric capacitive coupling between the F_0 signal trace and the converter input and/or reference connection traces. An immediate solution is to maintain maximum possible separation between the F_0 signal trace and the input/reference signals. When the F_0 signal is parallel terminated near the converter, substantial AC current is flowing in the loop formed by the F_0 connection trace, the termination and the ground return path. Thus, perturbation signals may be inductively coupled into the converter input and/or reference. In this situation, the user must reduce to a minimum the loop area for the F_0 signal as well as the loop area for the differential input and reference connections.

Driving the Input and Reference

The input and reference pins of the LTC2414/LTC2418 converters are directly connected to a network of sampling capacitors. Depending upon the relation between the differential input voltage and the differential reference voltage, these capacitors are switching between these four pins transferring small amounts of charge in the process. A simplified equivalent circuit is shown in Figure 11.

For a simple approximation, the source impedance R_S driving an analog input pin (IN^+ , IN^- , REF^+ or REF^-) can be considered to form, together with R_{SW} and C_{EQ} (see Figure 11), a first order passive network with a time constant $\tau = (R_S + R_{SW}) \cdot C_{EQ}$. The converter is able to sample the input signal with better than 1ppm accuracy if the sampling period is at least 14 times greater than the input circuit time constant τ . The sampling process on the four input analog pins is quasi-independent so each time constant should be considered by itself and, under worst-case circumstances, the errors may add.

When using the internal oscillator ($F_0 = LOW$ or $HIGH$), the LTC2414/LTC2418's front-end switched-capacitor network is clocked at 76800Hz corresponding to a 13 μs sampling period. Thus, for settling errors of less than 1ppm, the driving source impedance should be chosen such that $\tau \leq 13\mu s / 14 = 920ns$. When an external oscillator of frequency f_{EOSC} is used, the sampling period is $2/f_{EOSC}$ and, for a settling error of less than 1ppm, $\tau \leq 0.14/f_{EOSC}$.

APPLICATIONS INFORMATION

Input Current

If complete settling occurs on the input, conversion results will be unaffected by the dynamic input current. An incomplete settling of the input signal sampling process may result in gain and offset errors, but it will not degrade the INL performance of the converter. Figure 11 shows the mathematical expressions for the average bias currents flowing through the IN⁺ and IN⁻ pins as a result of the sampling charge transfers when integrated over a substantial time period (longer than 64 internal clock cycles).

The effect of this input dynamic current can be analyzed using the test circuit of Figure 12. The C_{PAR} capacitor includes the LTC2414/LTC2418 pin capacitance (5pF typical) plus the capacitance of the test fixture used to obtain the results shown in Figures 13 and 14. A careful implementation can bring the total input capacitance (C_{IN} + C_{PAR}) closer to 5pF thus achieving better performance than the one predicted by Figures 13 and 14. For simplicity, two distinct situations can be considered.

For relatively small values of input capacitance (C_{IN} < 0.01μF), the voltage on the sampling capacitor settles almost completely and relatively large values for the source

impedance result in only small errors. Such values for C_{IN} will deteriorate the converter offset and gain performance without significant benefits of signal filtering and the user is advised to avoid them. Nevertheless, when small values of C_{IN} are unavoidably present as parasitics of input multiplexers, wires, connectors or sensors, the LTC2414/LTC2418 can maintain its exceptional accuracy while operating with relative large values of source resistance as shown in Figures 13 and 14. These measured results may be slightly different from the first order approximation suggested earlier because they include the effect of the actual second order input network together with the nonlinear settling process of the input amplifiers. For small C_{IN} values, the settling on IN⁺ and IN⁻ occurs almost independently and there is little benefit in trying to match the source impedance for the two pins.

Larger values of input capacitors (C_{IN} > 0.01μF) may be required in certain configurations for antialiasing or general input signal filtering. Such capacitors will average the input sampling charge and the external source resistance will see a quasi constant input differential impedance. When F₀ = LOW (internal oscillator and 60Hz notch), the

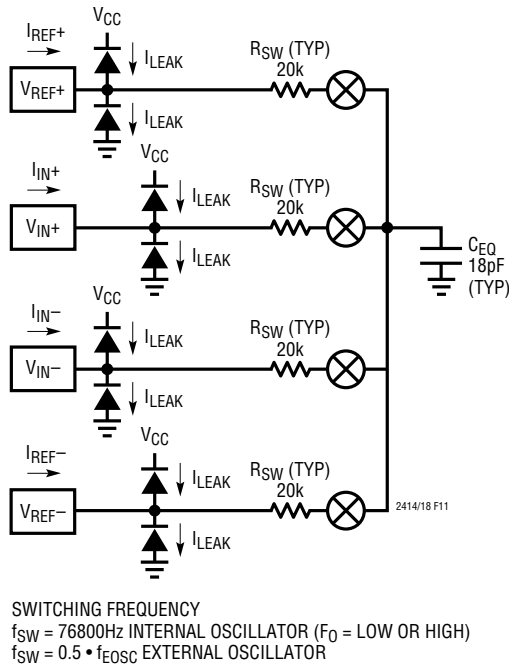

$$I(IN^+)_{AVG} = \frac{V_{IN} + V_{INCM} - V_{REFCM}}{0.5 \cdot R_{EQ}}$$

$$I(IN^-)_{AVG} = \frac{-V_{IN} + V_{INCM} - V_{REFCM}}{0.5 \cdot R_{EQ}}$$

$$I(REF^+)_{AVG} = \frac{1.5 \cdot V_{REF} - V_{INCM} + V_{REFCM}}{0.5 \cdot R_{EQ}} - \frac{V_{IN}^2}{V_{REF} \cdot R_{EQ}}$$

$$I(REF^-)_{AVG} = \frac{-1.5 \cdot V_{REF} - V_{INCM} + V_{REFCM}}{0.5 \cdot R_{EQ}} + \frac{V_{IN}^2}{V_{REF} \cdot R_{EQ}}$$

where:

$$V_{REF} = REF^+ - REF^-$$

$$V_{REFCM} = \left(\frac{REF^+ + REF^-}{2} \right)$$

$$V_{IN} = IN^+ - IN^-$$

$$V_{INCM} = \left(\frac{IN^+ + IN^-}{2} \right)$$

$$R_{EQ} = 3.61M\Omega \text{ INTERNAL OSCILLATOR } 60\text{Hz Notch } (F_0 = \text{LOW})$$

$$R_{EQ} = 4.32M\Omega \text{ INTERNAL OSCILLATOR } 50\text{Hz Notch } (F_0 = \text{HIGH})$$

$$R_{EQ} = (0.555 \cdot 10^{12}) / f_{EOSC} \text{ EXTERNAL OSCILLATOR}$$

Figure 11. LTC2414/LTC2418 Equivalent Analog Input Circuit

APPLICATIONS INFORMATION

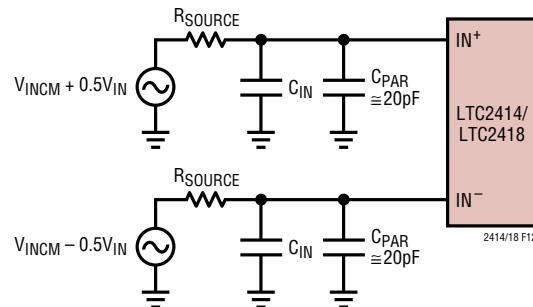
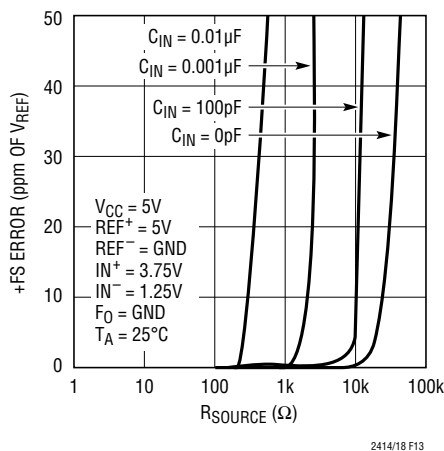
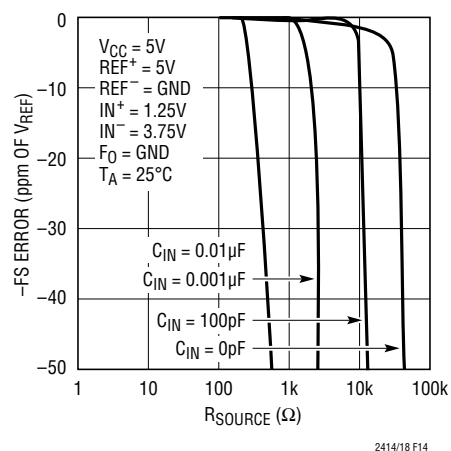
Figure 12. An RC Network at IN⁺ and IN⁻Figure 13. +FS Error vs R_{SOURCE} at IN⁺ or IN⁻ (Small C_{IN})Figure 14. -FS Error vs R_{SOURCE} at IN⁺ or IN⁻ (Small C_{IN})

typical differential input resistance is 1.8MΩ which will generate a gain error of approximately 0.28ppm for each ohm of source resistance driving IN⁺ or IN⁻. When F_O = HIGH (internal oscillator and 50Hz notch), the typical differential input resistance is 2.16MΩ which will generate a gain error of approximately 0.23ppm for each ohm of source resistance driving IN⁺ or IN⁻. When F_O is driven by an external oscillator with a frequency f_{EOSC} (external conversion clock operation), the typical differential input resistance is $0.28 \cdot 10^{12}/f_{EOSC} \Omega$ and each ohm of source resistance driving IN⁺ or IN⁻ will result in $1.78 \cdot 10^{-6} \cdot f_{EOSC}$ ppm gain error. The effect of the source resistance on the two input pins is additive with respect to this gain error. The typical +FS and -FS errors as a function of the sum of the source resistance seen by IN⁺ and IN⁻ for large values of C_{IN} are shown in Figures 15 and 16.

In addition to this gain error, an offset error term may also appear. The offset error is proportional with the mismatch between the source impedance driving the two

input pins IN⁺ and IN⁻ and with the difference between the input and reference common mode voltages. While the input drive circuit nonzero source impedance combined with the converter average input current will not degrade the INL performance, indirect distortion may result from the modulation of the offset error by the common mode component of the input signal. Thus, when using large C_{IN} capacitor values, it is advisable to carefully match the source impedance seen by the IN⁺ and IN⁻ pins. When F_O = LOW (internal oscillator and 60Hz notch), every 1Ω mismatch in source impedance transforms a full-scale common mode input signal into a differential mode input signal of 0.28ppm. When F_O = HIGH (internal oscillator and 50Hz notch), every 1Ω mismatch in source impedance transforms a full-scale common mode input signal into a differential mode input signal of 0.23ppm. When F_O is driven by an external oscillator with a frequency f_{EOSC}, every 1Ω mismatch in source impedance transforms a full-scale common mode input signal into a differential mode input signal of

APPLICATIONS INFORMATION

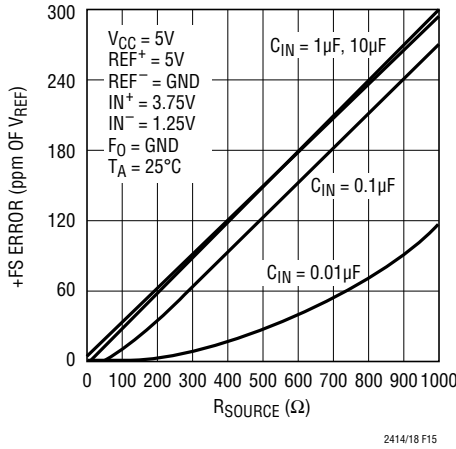

Figure 15. +FS Error vs R_{SOURCE} at IN⁺ or IN⁻ (Large C_{IN})

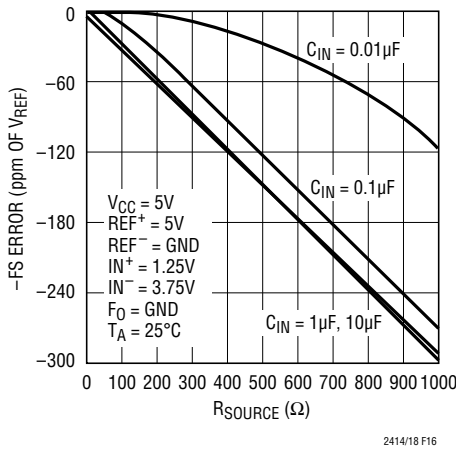

Figure 16. -FS Error vs R_{SOURCE} at IN⁺ or IN⁻ (Large C_{IN})

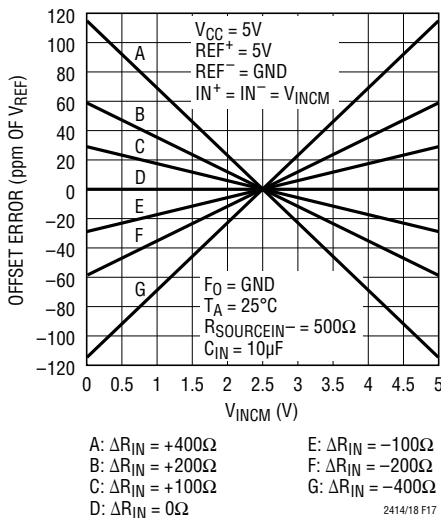

Figure 17. Offset Error vs Common Mode Voltage (V_{INCM} = IN⁺ = IN⁻) and Input Source Resistance Imbalance (ΔR_{IN} = R_{SOURCEIN+} - R_{SOURCEIN-}) for Large C_{IN} Values (C_{IN} ≥ 1 μF)

$1.78 \cdot 10^{-6} \cdot f_{EOSC} \text{ppm}$. Figure 17 shows the typical offset error due to input common mode voltage for various values of source resistance imbalance between the IN⁺ and IN⁻ pins when large C_{IN} values are used.

If possible, it is desirable to operate with the input signal common mode voltage very close to the reference signal common mode voltage as is the case in the ratiometric measurement of a symmetric bridge. This configuration eliminates the offset error caused by mismatched source impedances.

The magnitude of the dynamic input current depends upon the size of the very stable internal sampling capacitors and upon the accuracy of the converter sampling clock. The accuracy of the internal clock over the entire temperature and power supply range is typical better than 0.5%. Such a specification can also be easily achieved by an external clock. When relatively stable resistors (50ppm/°C) are used for the external source impedance seen by IN⁺ and IN⁻, the expected drift of the dynamic current, offset and gain errors will be insignificant (about 1% of their respective values over the entire temperature and voltage range). Even for the most stringent applications, a one-time calibration operation may be sufficient.

In addition to the input sampling charge, the input ESD protection diodes have a temperature dependent leakage current. This current, nominally 1nA (±10nA max), results in a small offset shift. A 100Ω source resistance will create a 0.1 μV typical and 1 μV maximum offset voltage.

Reference Current

In a similar fashion, the LTC2414/LTC2418 samples the differential reference pins REF⁺ and REF⁻ transferring small amount of charge to and from the external driving circuits thus producing a dynamic reference current. This current does not change the converter offset, but it may degrade the gain and INL performance. The effect of this current can be analyzed in the same two distinct situations.

For relatively small values of the external reference capacitors (C_{REF} < 0.01 μF), the voltage on the sampling capacitor settles almost completely and relatively large values for the source impedance result in only small errors. Such

APPLICATIONS INFORMATION

values for C_{REF} will deteriorate the converter offset and gain performance without significant benefits of reference filtering and the user is advised to avoid them.

Larger values of reference capacitors ($C_{REF} > 0.01\mu\text{F}$) may be required as reference filters in certain configurations. Such capacitors will average the reference sampling charge and the external source resistance will see a quasi constant reference differential impedance. When $F_0 = \text{LOW}$ (internal oscillator and 60Hz notch), the typical differential reference resistance is $1.3\text{M}\Omega$ which will generate a gain error of approximately 0.38ppm for each ohm of source resistance driving REF^+ or REF^- . When $F_0 = \text{HIGH}$ (internal oscillator and 50Hz notch), the typical differential reference resistance is $1.56\text{M}\Omega$ which will generate a gain

error of approximately 0.32ppm for each ohm of source resistance driving REF^+ or REF^- . When F_0 is driven by an external oscillator with a frequency f_{EOSC} (external conversion clock operation), the typical differential reference resistance is $0.20 \cdot 10^{12}/f_{EOSC}\Omega$ and each ohm of source resistance driving REF^+ or REF^- will result in $2.47 \cdot 10^{-6} \cdot f_{EOSC}\text{ppm}$ gain error. The effect of the source resistance on the two reference pins is additive with respect to this gain error. The typical +FS and -FS errors for various combinations of source resistance seen by the REF^+ and REF^- pins and external capacitance C_{REF} connected to these pins are shown in Figures 18, 19, 20 and 21.

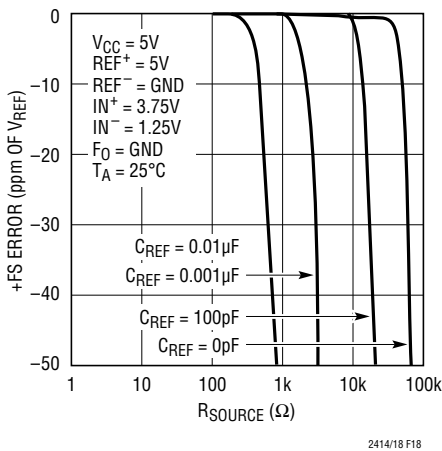

Figure 18. +FS Error vs R_{SOURCE} at REF^+ or REF^- (Small C_{IN})

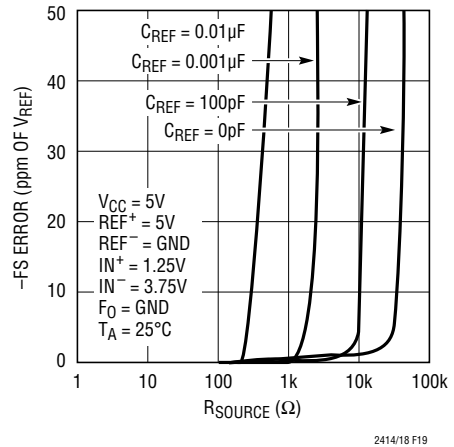

Figure 19. -FS Error vs R_{SOURCE} at REF^+ or REF^- (Small C_{IN})

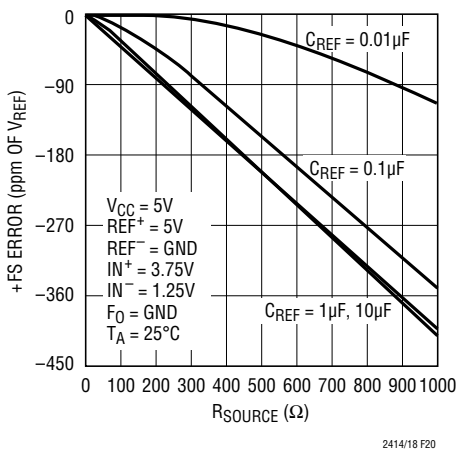

Figure 20. +FS Error vs R_{SOURCE} at REF^+ and REF^- (Large C_{REF})

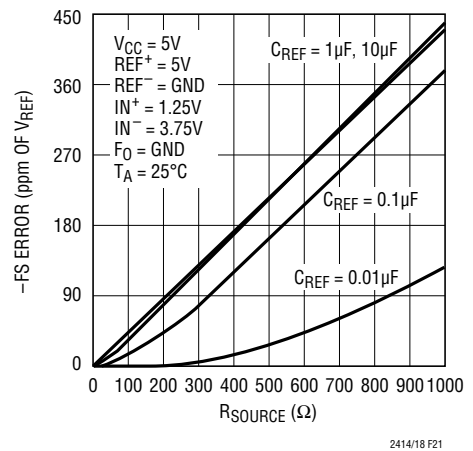

Figure 21. -FS Error vs R_{SOURCE} at REF^+ and REF^- (Large C_{REF})

APPLICATIONS INFORMATION

In addition to this gain error, the converter INL performance is degraded by the reference source impedance. When $F_0 = \text{LOW}$ (internal oscillator and 60Hz notch), every 100Ω of source resistance driving REF^+ or REF^- translates into about 1.34ppm additional INL error. When $F_0 = \text{HIGH}$ (internal oscillator and 50Hz notch), every 100Ω of source resistance driving REF^+ or REF^- translates into about 1.1ppm additional INL error. When F_0 is driven by an external oscillator with a frequency f_{EOSC} , every 100Ω of source resistance driving REF^+ or REF^- translates into about $8.73 \cdot 10^{-6} \cdot f_{\text{EOSC}}$ ppm additional INL error. Figure 22 shows the typical INL error due to the source resistance driving the REF^+ or REF^- pins when large C_{REF} values are used. The effect of the source resistance on the two reference pins is additive with respect to this INL error. In general, matching of source impedance for the REF^+ and REF^- pins does not help the gain or the INL error. The user is thus advised to minimize the combined source impedance driving the REF^+ and REF^- pins rather than to try to match it.

The magnitude of the dynamic reference current depends upon the size of the very stable internal sampling capacitors and upon the accuracy of the converter sampling clock. The accuracy of the internal clock over the entire temperature and power supply range is typical better than 0.5%. Such a specification can also be easily achieved by an external

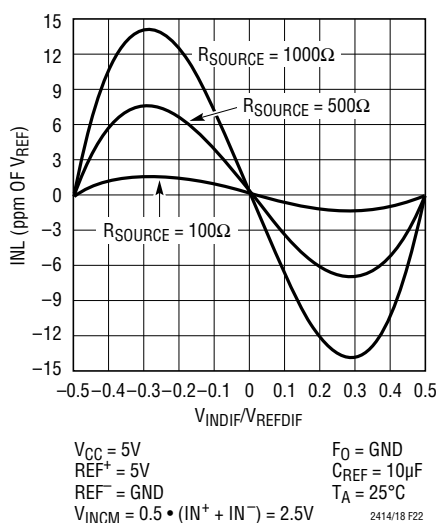

Figure 22. INL vs Differential Input Voltage ($V_{\text{IN}} = \text{IN}^+ - \text{IN}^-$) and Reference Source Resistance (R_{SOURCE} at REF^+ and REF^- for Large C_{REF} Values ($C_{\text{REF}} \geq 1\mu\text{F}$)

clock. When relatively stable resistors ($50\text{ppm}/^\circ\text{C}$) are used for the external source impedance seen by REF^+ and REF^- , the expected drift of the dynamic current gain error will be insignificant (about 1% of its value over the entire temperature and voltage range). Even for the most stringent applications a onetime calibration operation may be sufficient.

In addition to the reference sampling charge, the reference pins ESD protection diodes have a temperature dependent leakage current. This leakage current, nominally 1nA ($\pm 10\text{nA}$ max), results in a small gain error. A 100Ω source resistance will create a $0.05\mu\text{V}$ typical and $0.5\mu\text{V}$ maximum full-scale error.

Output Data Rate

When using its internal oscillator, the LTC2414/LTC2418 can produce up to 7.5 readings per second with a notch frequency of 60Hz ($F_0 = \text{LOW}$) and 6.25 readings per second with a notch frequency of 50Hz ($F_0 = \text{HIGH}$). The actual output data rate will depend upon the length of the sleep and data output phases which are controlled by the user and which can be made insignificantly short. When operated with an external conversion clock (F_0 connected to an external oscillator), the LTC2414/LTC2418 output data rate can be increased as desired up to that determined by the maximum f_{EOSC} frequency of 500kHz. The duration of the conversion phase is $20510/f_{\text{EOSC}}$. If $f_{\text{EOSC}} = 153600\text{Hz}$, the converter behaves as if the internal oscillator is used and the notch is set at 60Hz. There is no significant difference in the LTC2414/LTC2418 performance between these two operation modes.

An increase in f_{EOSC} over the nominal 153600Hz will translate into a proportional increase in the maximum output data rate. This substantial advantage is nevertheless accompanied by three potential effects, which must be carefully considered.

First, a change in f_{EOSC} will result in a proportional change in the internal notch position and in a reduction of the converter differential mode rejection at the power line frequency. In many applications, the subsequent performance degradation can be substantially reduced by relying upon the LTC2414/LTC2418's exceptional common mode

APPLICATIONS INFORMATION

rejection and by carefully eliminating common mode to differential mode conversion sources in the input circuit. The user should avoid single-ended input filters and should maintain a very high degree of matching and symmetry in the circuits driving the IN^+ and IN^- pins.

Second, the increase in clock frequency will increase proportionally the amount of sampling charge transferred through the input and the reference pins. If large external input and/or reference capacitors (C_{IN} , C_{REF}) are used, the previous section provides formulae for evaluating the effect of the source resistance upon the converter performance for any value of f_{EOSC} . If small external input and/or reference capacitors (C_{IN} , C_{REF}) are used, the effect of the external source resistance upon the LTC2414/LTC2418 typical performance can be inferred from Figures 12, 13, 18 and 19 in which the horizontal axis is scaled by $153600/f_{EOSC}$.

Third, an increase in the frequency of the external oscillator above 460800Hz (a more than 3x increase in the output data rate) will start to decrease the effectiveness of the internal autocalibration circuits. This will result in a progressive degradation in the converter accuracy and linearity. Typical measured performance curves for output data rates up to 25 readings per second are shown in Figures 23, 24, 25, 26, 27, 28, 29 and 30. In order to obtain the highest possible level of accuracy from this converter at output data rates above 7.5 readings per second, the user is advised to maximize the power supply voltage used and to limit the maximum ambient operating temperature. In certain circumstances, a reduction of the differential reference voltage may be beneficial.

Input Bandwidth

The combined effect of the internal Sinc⁴ digital filter and of the analog and digital autocalibration circuits determines the LTC2414/LTC2418 input bandwidth. When the internal oscillator is used with the notch set at 60Hz ($F_0 = LOW$), the 3dB input bandwidth is 3.63Hz. When the internal oscillator is used with the notch set at 50Hz ($F_0 = HIGH$), the 3dB input bandwidth is 3.02Hz. If an external conversion clock generator of frequency f_{EOSC} is connected to the F_0 pin, the 3dB input bandwidth is $0.236 \cdot 10^{-6} \cdot f_{EOSC}$.

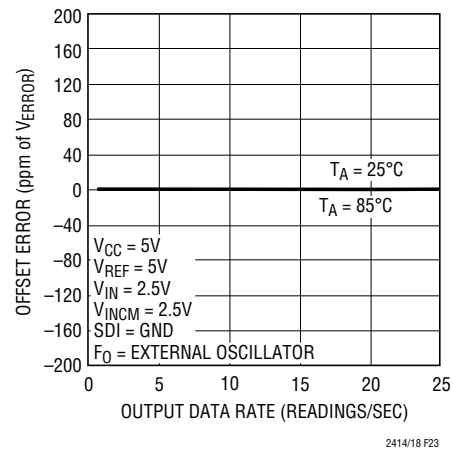

Figure 23. Offset Error vs Output Data Rate and Temperature

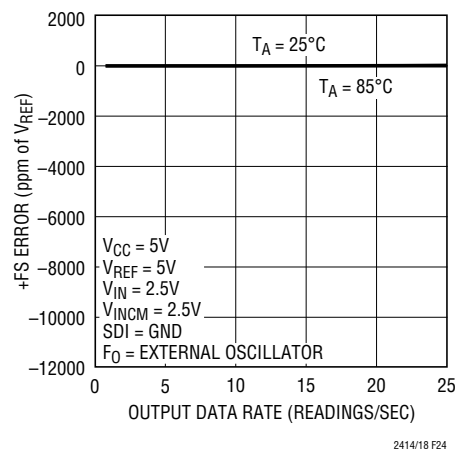

Figure 24. +FS Error vs Output Data Rate and Temperature

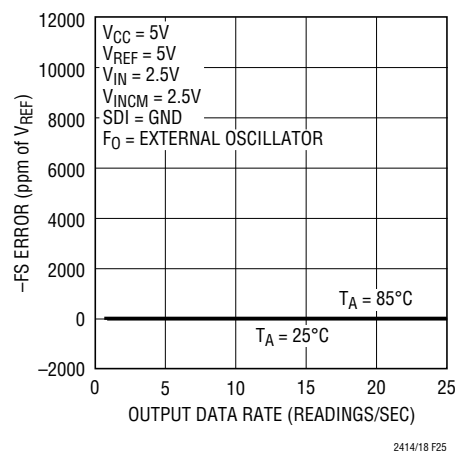

Figure 25. -FS Error vs Output Data Rate and Temperature

APPLICATIONS INFORMATION

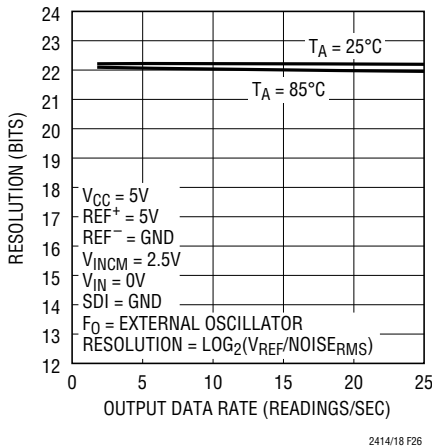

Figure 26. Resolution ($\text{Noise}_{\text{RMS}} \leq 1\text{LSB}$) vs Output Data Rate and Temperature

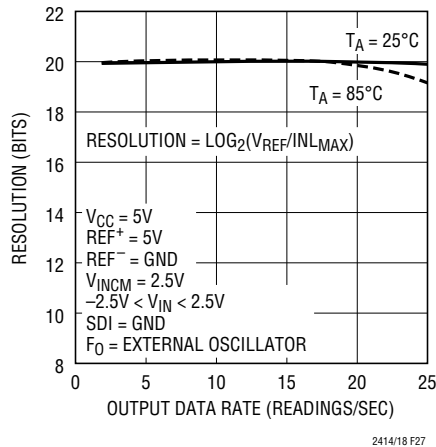

Figure 27. Resolution ($\text{INL}_{\text{RMS}} \leq 1\text{LSB}$) vs Output Data Rate and Temperature

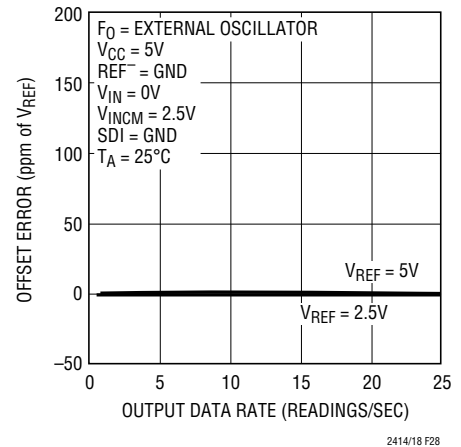

Figure 28. Offset Error vs Output Data Rate and Reference Voltage

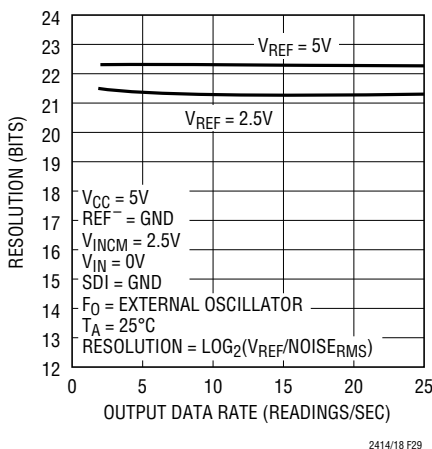

Figure 29. Resolution ($\text{Noise}_{\text{RMS}} \leq 1\text{LSB}$) vs Output Data Rate and Reference Voltage

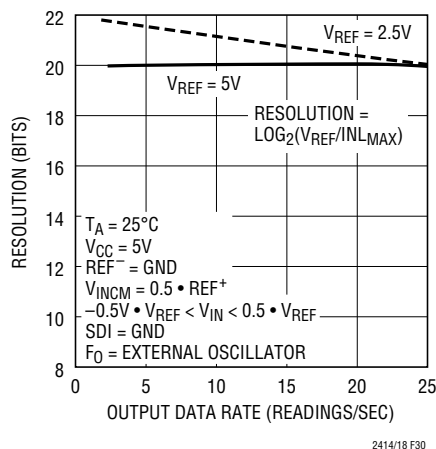

Figure 30. Resolution ($\text{INL}_{\text{MAX}} \leq 1\text{LSB}$) vs Output Data Rate and Reference Voltage

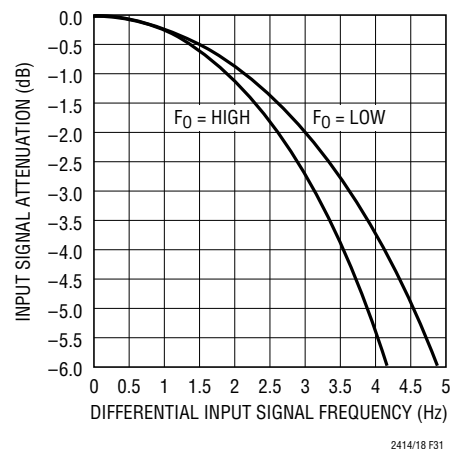

Figure 31. Input Signal Bandwidth Using the Internal Oscillator

Due to the complex filtering and calibration algorithms utilized, the converter input bandwidth is not modeled very accurately by a first order filter with the pole located at the 3dB frequency. When the internal oscillator is used, the shape of the LTC2414/LTC2418 input bandwidth is shown in Figure 31 for $F_0 = \text{LOW}$ and $F_0 = \text{HIGH}$. When an external oscillator of frequency f_{OSC} is used, the shape of the LTC2414/LTC2418 input bandwidth can be derived from Figure 31, $F_0 = \text{LOW}$ curve in which the horizontal axis is scaled by $f_{\text{OSC}}/153600$.

The conversion noise ($1\mu\text{V}_{\text{RMS}}$ typical for $V_{\text{REF}} = 5\text{V}$) can be modeled by a white noise source connected to a noise

free converter. The noise spectral density is $78\text{nV}/\sqrt{\text{Hz}}$ for an infinite bandwidth source and $107\text{nV}/\sqrt{\text{Hz}}$ for a single 0.5MHz pole source. From these numbers, it is clear that particular attention must be given to the design of external amplification circuits. Such circuits face the simultaneous requirements of very low bandwidth (just a few Hz) in order to reduce the output referred noise and relatively high bandwidth (at least 500kHz) necessary to drive the input switched-capacitor network. A possible solution is a high gain, low bandwidth amplifier stage followed by a high bandwidth unity-gain buffer.

APPLICATIONS INFORMATION

When external amplifiers are driving the LTC2414/LTC2418, the ADC input referred system noise calculation can be simplified by Figure 32. The noise of an amplifier driving the LTC2414/LTC2418 input pin can be modeled as a band limited white noise source. Its bandwidth can be approximated by the bandwidth of a single pole lowpass filter with a corner frequency f_i . The amplifier noise spectral density is n_i . From Figure 32, using f_i as the x-axis selector, we can find on the y-axis the noise equivalent bandwidth $freq_i$ of the input driving amplifier. This bandwidth includes the band limiting effects of the ADC internal calibration and filtering. The noise of the driving amplifier referred to the converter input and including all these effects can be calculated as $N = n_i \cdot \sqrt{freq_i}$. The total system noise (referred to the LTC2414/LTC2418 input) can now be obtained by summing as square root of sum of squares the three ADC input referred noise sources: the LTC2414/LTC2418 internal noise (1 μ V), the noise of the IN⁺ driving amplifier and the noise of the IN⁻ driving amplifier.

If the F₀ pin is driven by an external oscillator of frequency f_{EOSC} , Figure 32 can still be used for noise calculation if the x-axis is scaled by $f_{EOSC}/153600$. For large values of the ratio $f_{EOSC}/153600$, the Figure 32 plot accuracy begins to decrease, but in the same time the LTC2414/LTC2418 noise floor rises and the noise contribution of the driving amplifiers lose significance.

Normal Mode Rejection and Antialiasing

One of the advantages delta-sigma ADCs offer over conventional ADCs is on-chip digital filtering. Combined with a large oversampling ratio, the LTC2414/LTC2418 significantly simplify antialiasing filter requirements.

The Sinc⁴ digital filter provides greater than 120dB normal mode rejection at all frequencies except DC and integer multiples of the modulator sampling frequency (f_S). The LTC2414/LTC2418's autocalibration circuits further simplify the antialiasing requirements by additional normal mode signal filtering both in the analog and digital domain. Independent of the operating mode, $f_S = 256 \cdot f_N = 2048 \cdot f_{OUTMAX}$ where f_N in the notch frequency and f_{OUTMAX} is the maximum output data rate. In the internal oscillator mode with a 50Hz notch setting, $f_S = 12800$ Hz and with a 60Hz notch setting $f_S = 15360$ Hz. In the external oscillator mode, $f_S = f_{EOSC}/10$.

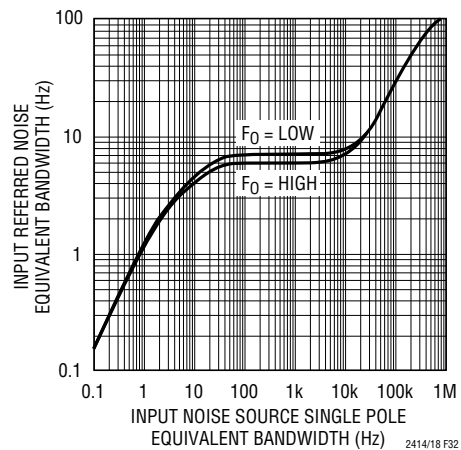

Figure 32. Input Referred Noise Equivalent Bandwidth of an Input Connected White Noise Source

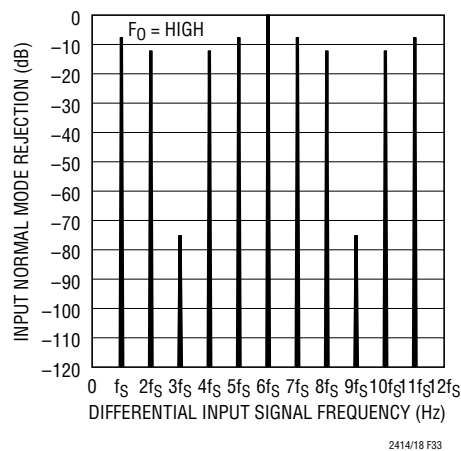

Figure 33. Input Normal Mode Rejection, Internal Oscillator and 50Hz Notch

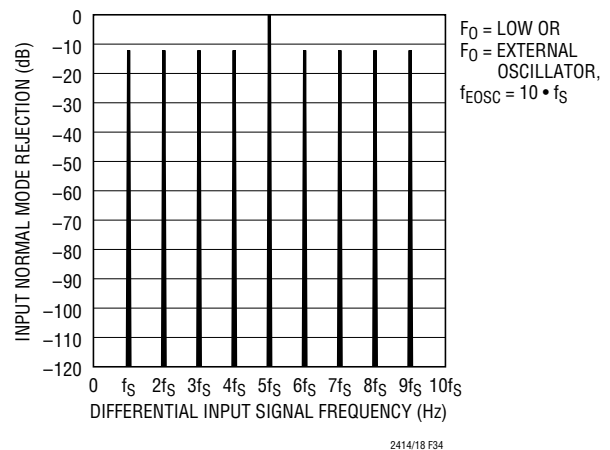

Figure 34. Input Normal Mode Rejection, Internal Oscillator and 60Hz Notch or External Oscillator

241418fb

APPLICATIONS INFORMATION

The combined normal mode rejection performance is shown in Figure 33 for the internal oscillator with 50Hz notch setting ($F_0 = \text{HIGH}$) and in Figure 34 for the internal oscillator with 60Hz notch setting ($F_0 = \text{LOW}$) and for the external oscillator mode. The regions of low rejection occurring at integer multiples of f_S have a very narrow bandwidth. Magnified details of the normal mode rejection curves are shown in Figure 35 (rejection near DC) and Figure 36 (rejection at $f_S = 256f_N$) where f_N represents the notch frequency. These curves have been derived for the external oscillator mode but they can be used in all operating modes by appropriately selecting the f_N value.

The user can expect to achieve in practice this level of performance using the internal oscillator as it is demonstrated by Figures 37 and 38. Typical measured values of the normal mode rejection of the LTC2414/LTC2418

operating with an internal oscillator and a 60Hz notch setting are shown in Figure 37 superimposed over the theoretical calculated curve. Similarly, typical measured values of the normal mode rejection of the LTC2414/LTC2418 operating with an internal oscillator and a 50Hz notch setting are shown in Figure 38 superimposed over the theoretical calculated curve.

As a result of these remarkable normal mode specifications, minimal (if any) antialias filtering is required in front of the LTC2414/LTC2418. If passive RC components are placed in front of the LTC2414/LTC2418, the input dynamic current should be considered (see Input Current section). In cases where large effective RC time constants are used, an external buffer amplifier may be required to minimize the effects of dynamic input current.

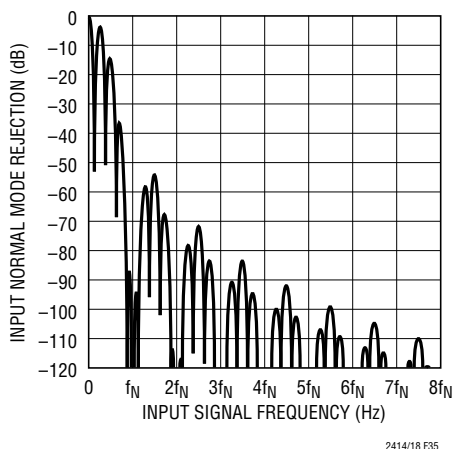

Figure 35. Input Normal Mode Rejection

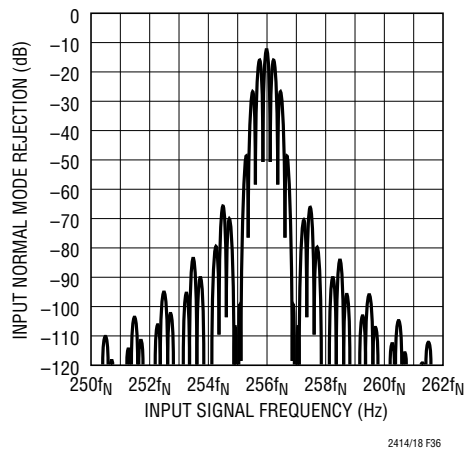
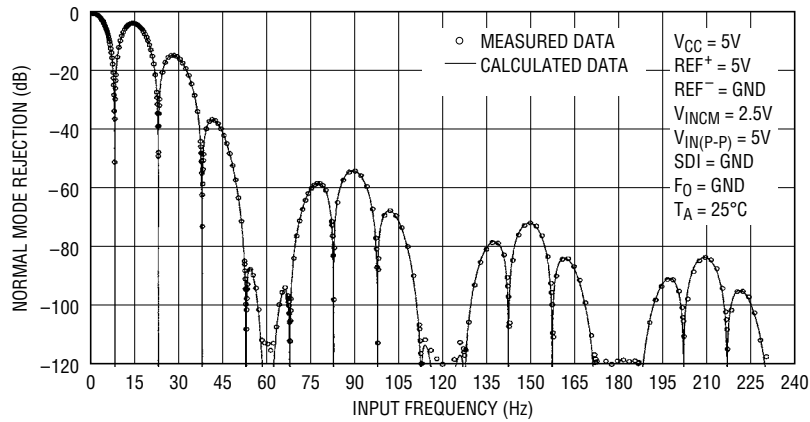

Figure 36. Input Normal Mode Rejection

APPLICATIONS INFORMATION



2414/18 F37

Figure 37. Input Normal Mode Rejection vs Input Frequency with Input Perturbation of 100% Full Scale (60Hz Notch)

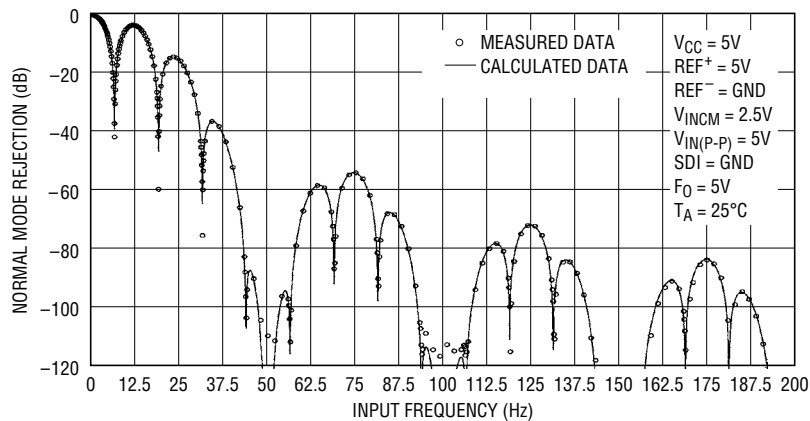

2414/18 F38

Figure 38. Input Normal Mode Rejection vs Input Frequency with Input Perturbation of 100% Full Scale (50Hz Notch)

APPLICATIONS INFORMATION

Traditional high order delta-sigma modulators, while providing very good linearity and resolution, suffer from potential instabilities at large input signal levels. The proprietary architecture used for the LTC2414/LTC2418 third order modulator resolves this problem and guarantees a predictable stable behavior at input signal levels of up to 150% of full scale. In many industrial applications, it is not uncommon to have to measure microvolt level signals superimposed over volt level perturbations and LTC2414/LTC2418 is eminently suited for such tasks. When the perturbation is differential, the specification of interest is the normal mode rejection for large input signal levels. With a reference voltage $V_{REF} = 5V$, the LTC2414/LTC2418 has a full-scale differential input range of 5V peak-to-peak.

Figures 39 and 40 show measurement results for the LTC2414/LTC2418 normal mode rejection ratio with a 7.5V peak-to-peak (150% of full scale) input signal superimposed over the more traditional normal mode rejection ratio results obtained with a 5V peak-to-peak (full scale) input signal. In Figure 39, the LTC2414/LTC2418 uses the internal oscillator with the notch set at 60Hz ($F_0 = \text{LOW}$) and in Figure 40 it uses the internal oscillator with the notch set at 50Hz ($F_0 = \text{HIGH}$). It is clear that the LTC2414/LTC2418 rejection performance is maintained with no compromises in this extreme situation. When operating with large input signal levels, the user must observe that such signals do not violate the device absolute maximum ratings.

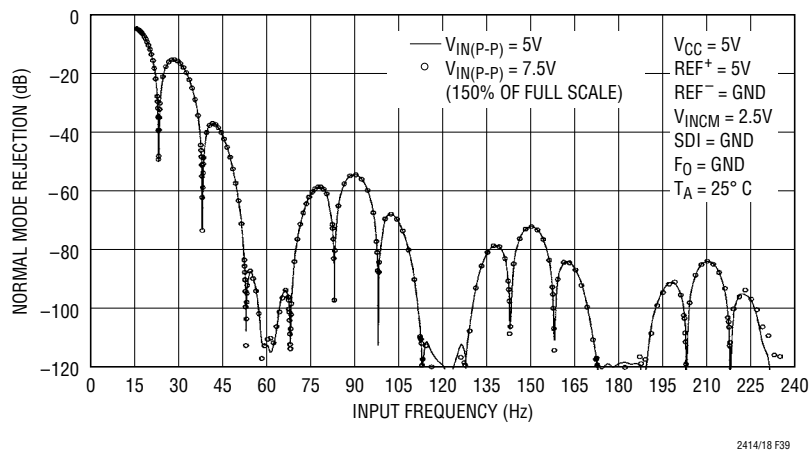

Figure 39. Measured Input Normal Mode Rejection vs Input Frequency with Input Perturbation of 150% Full Scale (60Hz Notch)

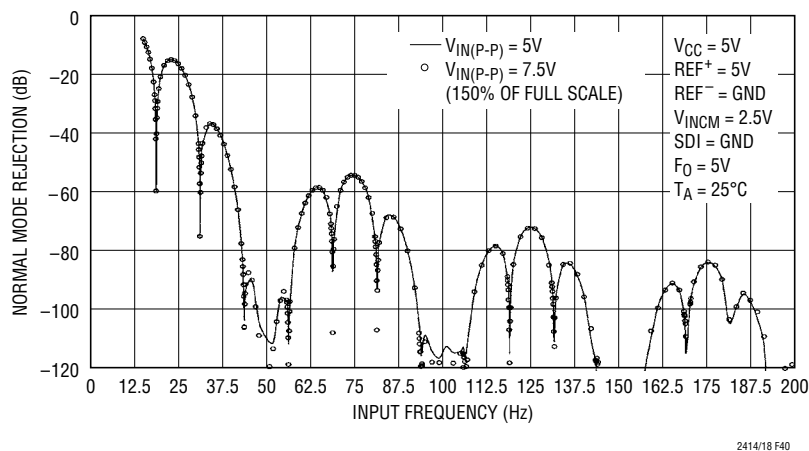

Figure 40. Measured Input Normal Mode Rejection vs Input Frequency with Input Perturbation of 150% Full Scale (50Hz Notch)

APPLICATIONS INFORMATION

BRIDGE APPLICATIONS

Typical strain gauge based bridges deliver only 2mV/Volt of excitation. As the maximum reference voltage of the LTC2414/LTC2418 is 5V, remote sensing of applied excitation without additional circuitry requires that excitation be limited to 5V. This gives only 10mV full scale input signal, which can be resolved to 1 part in 10000 without averaging. For many solid state sensors, this is still better than the sensor. Averaging 64 samples however reduces the noise level by a factor of eight, bringing the resolving power to 1 part in 80000, comparable to better weighing systems. Hysteresis and creep effects in the load cells are typically much greater than this. Most applications that require strain measurements to this level of accuracy are measuring slowly changing phenomena, hence the time required to average a large number of readings is usually not an issue. For those systems that require accurate measurement of a small incremental change on a significant tare weight, the lack of history effects in the LTC2400 family is of great benefit.

For those applications that cannot be fulfilled by the LTC2414/LTC2418 alone, compensating for error in external amplification can be done effectively due to the “no latency” feature of the LTC2414/LTC2418. No latency operation allows samples of the amplifier offset and gain to be interleaved with weighing measurements. The use of correlated double sampling allows suppression of 1/f noise, offset and thermocouple effects within the bridge. Correlated double sampling involves alternating the polarity of excitation and dealing with the reversal of input polarity mathematically. Alternatively, bridge excitation can be increased to as much as $\pm 10V$, if one of several precision attenuation techniques is used to produce a precision divide operation on the reference signal. Another option is the use of a reference within the 5V input range of the LTC2414/LTC2418 and developing excitation via fixed gain, or LTC1043 based voltage multiplication, along with remote feedback in the excitation amplifiers, as shown in Figures 46 and 47.

Figure 41 shows an example of a simple bridge connection. Note that it is suitable for any bridge application where measurement speed is not of the utmost importance. For many applications where large vessels are weighed,

the average weight over an extended period of time is of concern and short term weight is not readily determined due to movement of contents, or mechanical resonance. Often, large weighing applications involve load cells located at each load bearing point, the output of which can be summed passively prior to the signal processing circuitry, actively with amplification prior to the ADC, or can be digitized via multiple ADC channels and summed mathematically. The mathematical summation of the output of multiple LTC2414/LTC2418's provides the benefit of a root square reduction in noise. The low power consumption of the LTC2414/LTC2418 makes it attractive for multidrop communication schemes where the ADC is located within the load-cell housing.

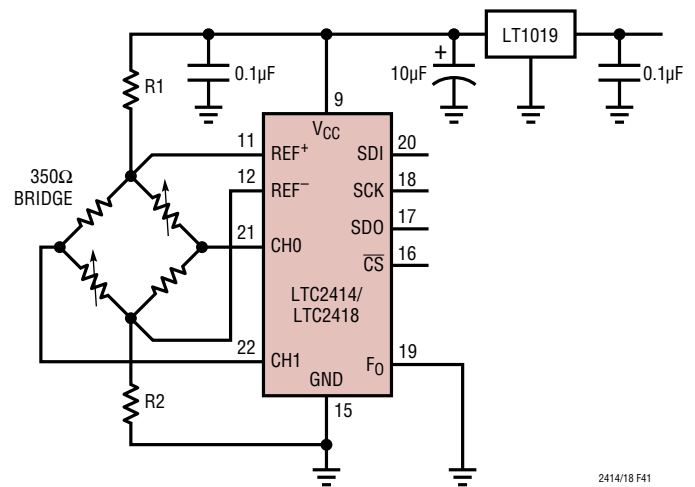

R1 AND R2 CAN BE USED TO INCREASE TOLERABLE AC COMPONENT ON REF SIGNALS

Figure 41. Simple Bridge Connection

A direct connection to a load cell is perhaps best incorporated into the load-cell body, as minimizing the distance to the sensor largely eliminates the need for protection devices, RFI suppression and wiring. The LTC2414/LTC2418 exhibits extremely low temperature dependent drift. As a result, exposure to external ambient temperature ranges does not compromise performance. The incorporation of any amplification considerably complicates thermal stability, as input offset voltages and currents, temperature coefficient of gain settling resistors all become factors.

APPLICATIONS INFORMATION

The circuit in Figure 42 shows an example of a simple amplification scheme. This example produces a differential output with a common mode voltage of 2.5V, as determined by the bridge. The use of a true three amplifier instrumentation amplifier is not necessary, as the LTC2414/LTC2418 has common mode rejection far beyond that of most amplifiers. The LTC1051 is a dual autozero amplifier that can be used to produce a gain of 15 before its input referred noise dominates the LTC2414/LTC2418 noise. This example shows a gain of 34, that is determined by a feedback network built using a resistor array containing 8 individual resistors. The resistors are organized to optimize temperature tracking in the presence of thermal gradients. The second LTC1051 buffers the low noise input stage from the transient load steps produced during conversion.

The gain stability and accuracy of this approach is very good, due to a statistical improvement in resistor matching. A gain of 34 may seem low, when compared to common practice in earlier generations of load-cell interfaces, however the accuracy of the LTC2414/LTC2418 changes

the rationale. Achieving high gain accuracy and linearity at higher gains may prove difficult, while providing little benefit in terms of noise reduction.

At a gain of 100, the gain error that could result from typical open-loop gain of 160dB is -1ppm, however, worst-case is at the minimum gain of 116dB, giving a gain error of -158ppm. Worst-case gain error at a gain of 34, is -54ppm. The use of the LTC1051A reduces the worst-case gain error to -33ppm. The advantage of gain higher than 34, then becomes dubious, as the input referred noise sees little improvement and gain accuracy is potentially compromised.

Note that this 4-amplifier topology has advantages over the typical integrated 3-amplifier instrumentation amplifier in that it does not have the high noise level common in the output stage that usually dominates when an instrumentation amplifier is used at low gain. If this amplifier is used at a gain of 10, the gain error is only 10ppm and input referred noise is reduced to 0.1 μ V_{RMS}. The buffer stages can also be configured to provide gain of up to 50 with high gain stability and linearity.

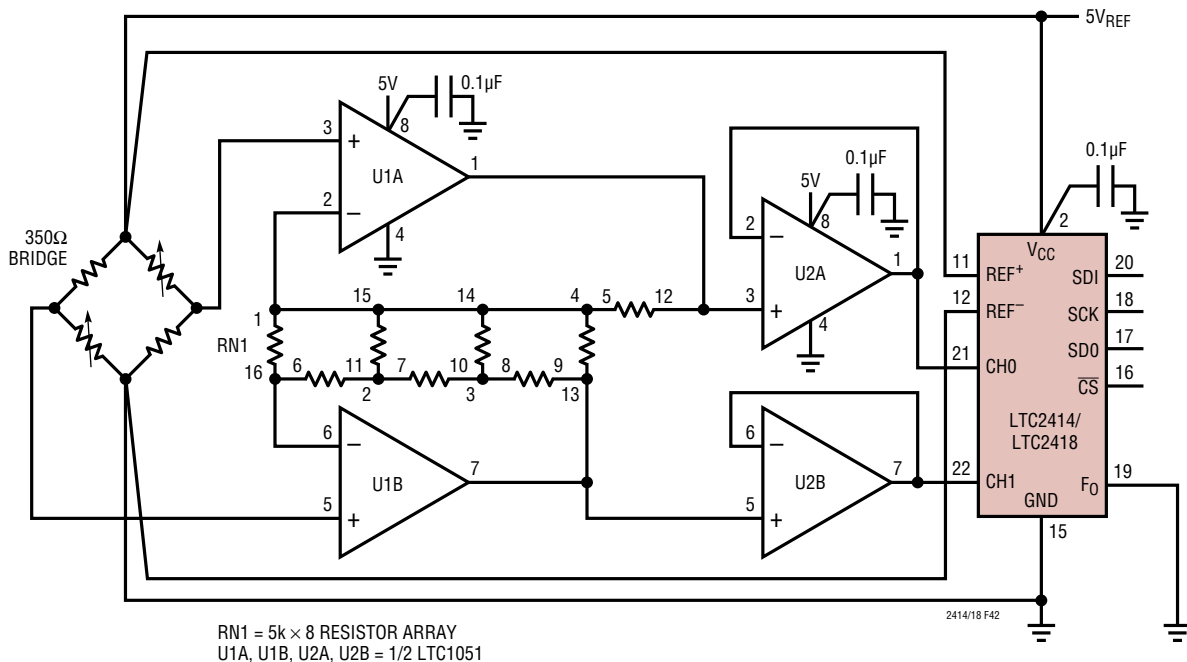

Figure 42. Using Autozero Amplifiers to Reduce Input Referred Noise

APPLICATIONS INFORMATION

Figure 43 shows an example of a single amplifier used to produce single-ended gain. This topology is best used in applications where the gain setting resistor can be made to match the temperature coefficient of the strain gauges. If the bridge is composed of precision resistors, with only one or two variable elements, the reference arm of the bridge can be made to act in conjunction with the feedback resistor to determine the gain. If the feedback resistor is incorporated into the design of the load cell, using resistors which match the temperature coefficient of the load-cell elements, good results can be achieved without the need for resistors with a high degree of absolute accuracy. The common mode voltage in this case, is again a function of the bridge output. Differential gain as used with a 350Ω bridge is $A_V = (R1 + R2)/(R1 + 175\Omega)$. Common mode gain is half the differential gain. The maximum differential signal that can be used is $1/4 V_{REF}$, as opposed to $1/2 V_{REF}$ in the 2-amplifier topology above.

Remote Half Bridge Interface

As opposed to full bridge applications, typical half bridge applications must contend with nonlinearity in the bridge output, as signal swing is often much greater. Applications include RTD's, thermistors and other resistive elements that undergo significant changes over their span. For single variable element bridges, the nonlinearity of the half bridge output can be eliminated completely; if the reference arm of the bridge is used as the reference to the ADC, as shown in Figure 44. The LTC2414/LTC2418 can accept inputs up to $1/2 V_{REF}$. Hence, the reference resistor R1 must be at least 2x the highest value of the variable resistor.

In the case of 100Ω platinum RTD's, this would suggest a value of 800Ω for R1. Such a low value for R1 is not advisable due to self-heating effects. A value of 25.5k is shown for R1, reducing self-heating effects to acceptable levels for most sensors.

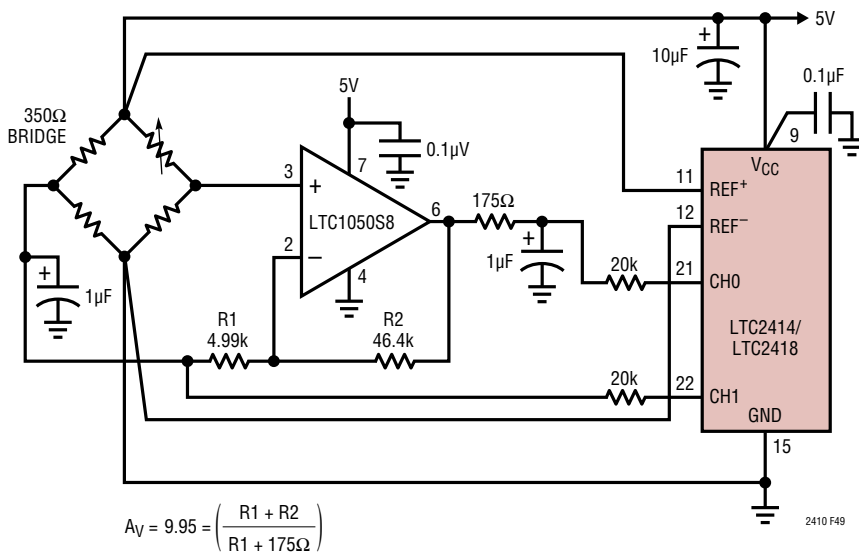

Figure 43. Bridge Amplification Using a Single Amplifier

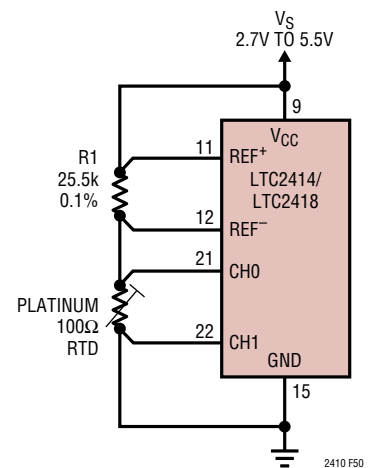

Figure 44. Remote Half Bridge Interface

APPLICATIONS INFORMATION

The basic circuit shown in Figure 44 shows connections for a full 4-wire connection to the sensor, which may be located remotely. The differential input connections will reject induced or coupled 60Hz interference, however, the reference inputs do not have the same rejection. If 60Hz or other noise is present on the reference input, a low pass filter is recommended as shown in Figure 45. Note that you cannot place a large capacitor directly at the junction of R1 and R2, as it will store charge from the sampling process. A better approach is to produce a low pass filter decoupled from the input lines with a high value resistor (R3).

The use of a third resistor in the half bridge, between the variable and fixed elements gives essentially the same result as the two resistor version, but has a few benefits. If, for example, a 25k reference resistor is used to set the excitation current with a 100Ω RTD, the negative reference input is sampling the same external node as the positive input and may result in errors if used with a long cable. For short cable applications, the errors may be acceptably low. If instead the single 25k resistor is replaced with a 10k 5% and a 10k 0.1% reference resistor, the noise level introduced at the reference, at least at higher frequencies, will be reduced. A filter can be introduced into the network, in the form of one or more capacitors, or ferrite beads, as long as the sampling pulses are not translated into an

error. The reference voltage is also reduced, but this is not undesirable, as it will decrease the value of the LSB, although, not the input referred noise level.

The circuit shown in Figure 45 shows a more rigorous example of Figure 44, with increased noise suppression and more protection for remote applications.

Figure 46 shows an example of gain in the excitation circuit and remote feedback from the bridge. The LTC1043's provide voltage multiplication, providing ±10V from a 5V reference with only 1ppm error. The amplifiers are used at unity gain and introduce very little error due to gain error or due to offset voltages. A 1μV/°C offset voltage drift translates into 0.05ppm/°C gain error. Simpler alternatives, with the amplifiers providing gain using resistor arrays for feedback, can produce results that are similar to bridge sensing schemes via attenuators. Note that the amplifiers must have high open-loop gain or gain error will be a source of error. The fact that input offset voltage has relatively little effect on overall error may lead one to use low performance amplifiers for this application. Note that the gain of a device such as an LF156, (25V/mV over temperature) will produce a worst-case error of -180ppm at a noise gain of 3, such as would be encountered in an inverting gain of 2, to produce -10V from a 5V reference.

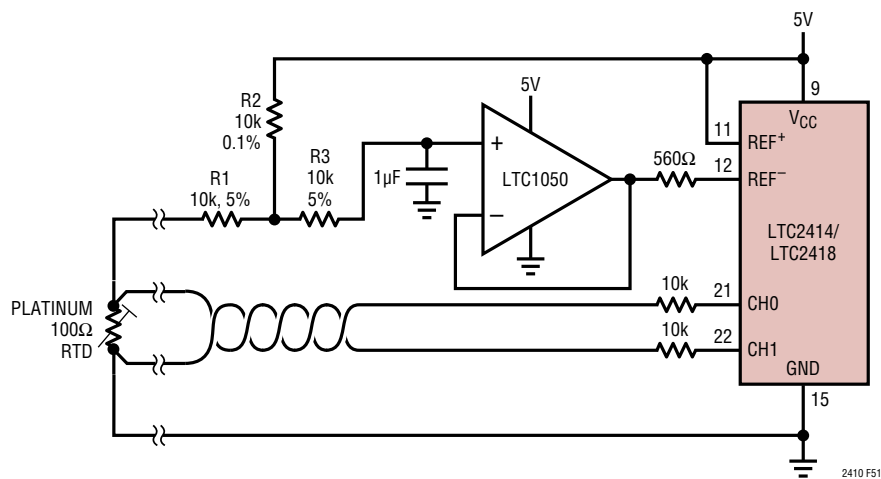

Figure 45. Remote Half Bridge Sensing with Noise Suppression on Reference

APPLICATIONS INFORMATION

The error associated with the 10V excitation would be -80ppm . Hence, overall reference error could be as high as 130ppm , the average of the two.

Figure 47 shows a similar scheme to provide excitation using resistor arrays to produce precise gain. The circuit

is configured to provide 10V and -5V excitation to the bridge, producing a common mode voltage at the input to the LTC2414/LTC2418 of 2.5V , maximizing the AC input range for applications where induced 60Hz could reach amplitudes up to 2V_{RMS} .

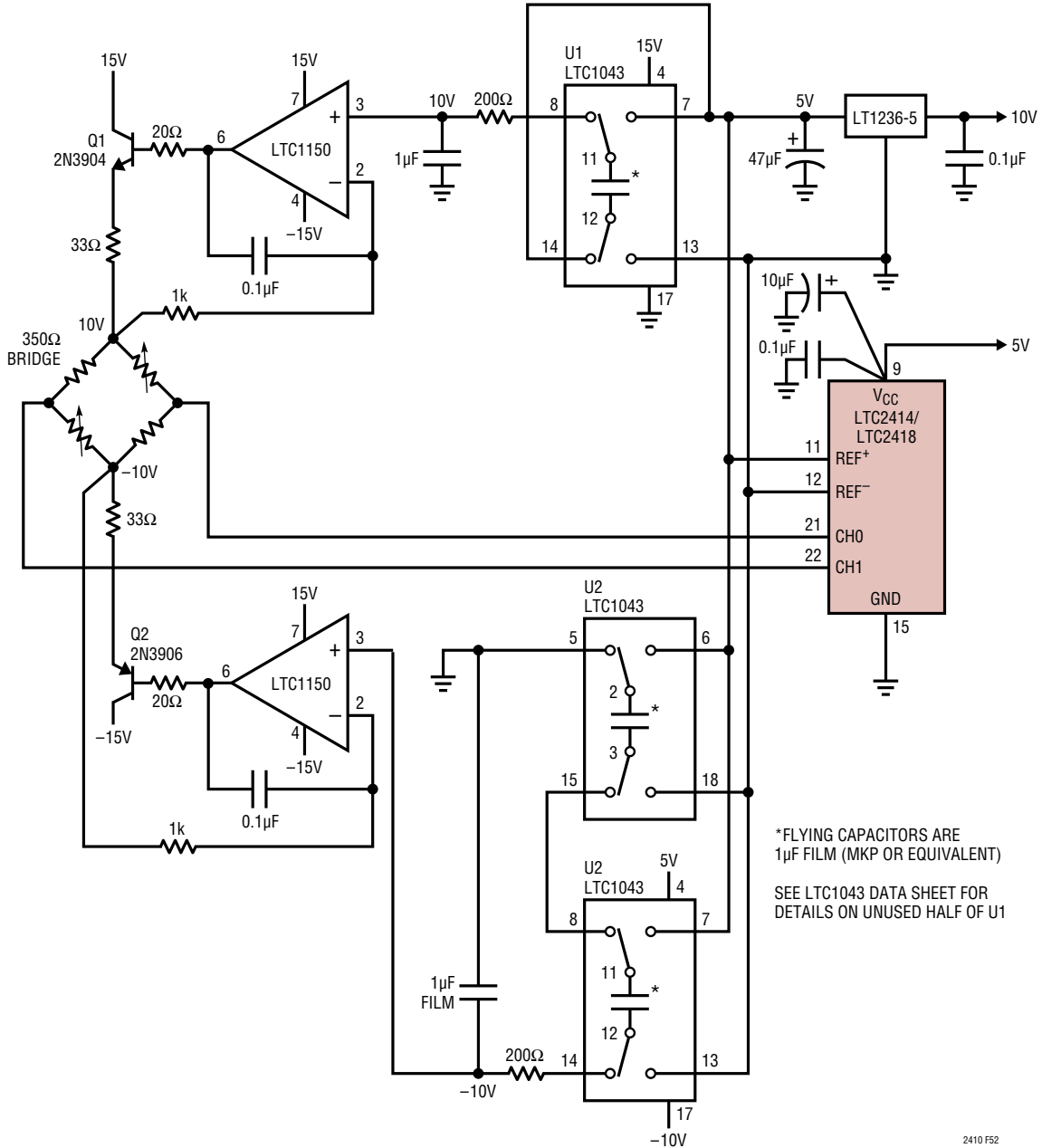

Figure 46. LTC1043 Provides Precise 4X Reference for Excitation Voltages

2410 F52

APPLICATIONS INFORMATION

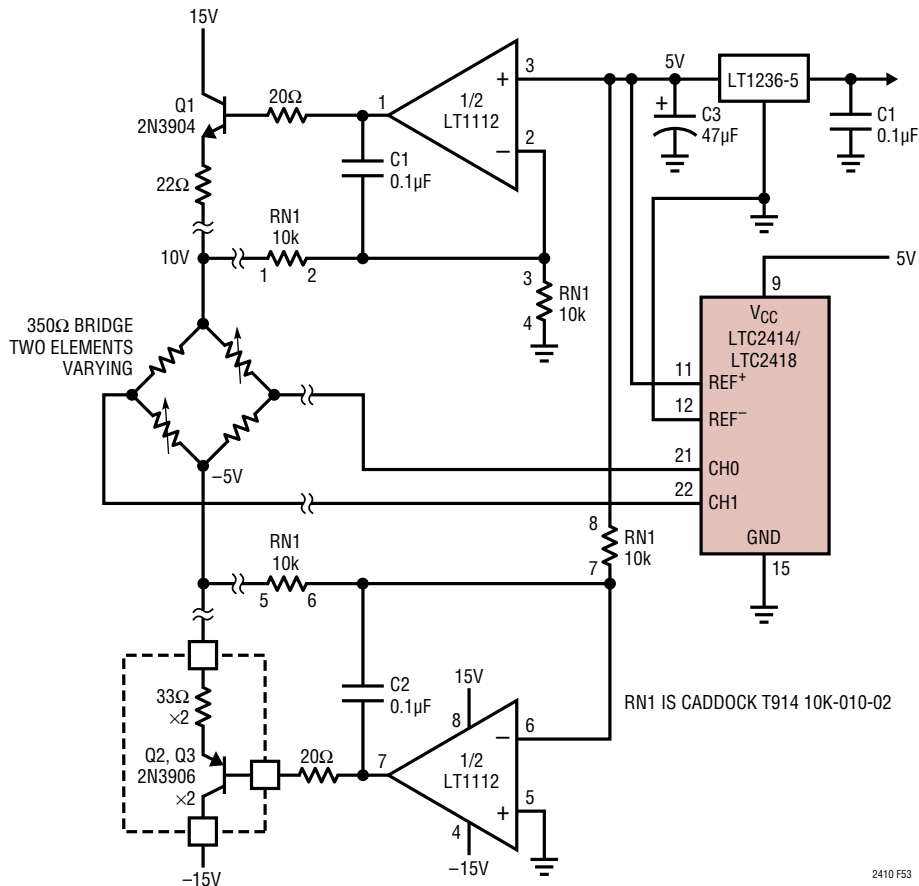

Figure 47. Use Resistor Arrays to Provide Precise Matching in Excitation Amplifier

MULTIPLE CHANNEL USAGE

The LTC2414/LTC2418 have up to sixteen input channels and this feature provides a very flexible and efficient solution in applications where more than one variable need to be measured.

Measurements of a Ladder of Sensors

In industrial process, it is likely that a large group of real world phenomena need to be monitored where the speed is not critical. One example is the cracking towers in petroleum refineries where a group of temperature measurements need to be taken and related. This is done by passing an excitation current through a ladder of RTDs. The configuration using a single LTC2418 to monitor up to eight RTDs in differential mode is shown in Figure 48. A high accuracy R1 is used to set the excitation current and the reference voltage. A larger value of 25k is se-

lected to reduce the self-heating effects. R1 can also be broken into two resistors, one 25k to set the excitation current and the other a high accuracy 1k resistor to set the reference voltage, assuming 100Ω platinum RTDs. This results in a reduced reference voltage and a reduced common mode difference between the reference and the input signal, which improves the conversion linearity and reduces total error.

Each input should be taken close to the related RTD to minimize the error caused by parasitic wire resistance. The interference on a signal transmission line from RTD to the LTC2418 is rejected due to the excellent common mode rejection and the digital LPF included in the LTC2418. It should be noted that the input source resistance of CH0 can have a maximum value of $800\Omega \cdot 8 = 6.4k$, so the parasitic capacitance and resistance of the connection wires need to be minimized in order not to degrade the converter performance.

APPLICATIONS INFORMATION

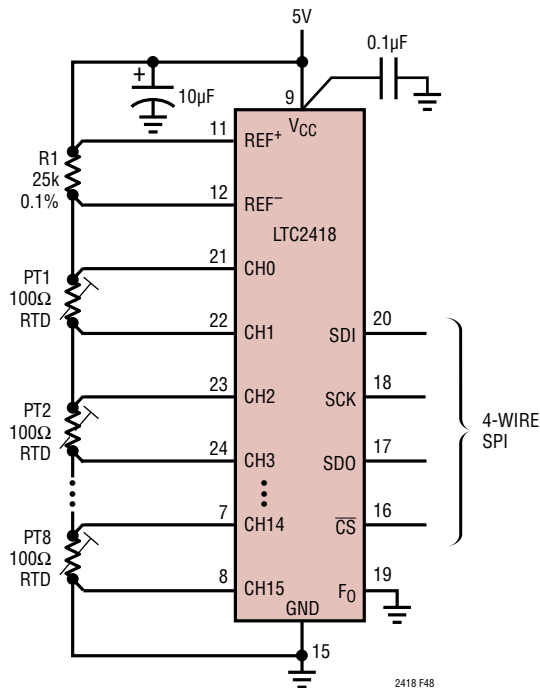

Figure 48. Measurement of a Ladder of Sensors Using Differential Mode

Multichannel Bridge Digitizer and Digital Cold Junction Compensation

The bridge application as shown in Figures 41, 42, and 43 can be expanded to multiple bridge transducers. Figure 54 shows the expansion for simple bridge measurement. Also included is the temperature measurement.

In Figure 54, CH0 to CH13 are configured as differential to measure up to seven bridge transducers using the LTC2418. CH14 and CH15 are configured as single-ended. CH14 measures the thermocouple while CH15 measures the output of the cold junction sensor (diode, thermistor, etc.). The measured cold junction sensor output is then used to compensate the thermocouple output to find the absolute temperature. The final temperature value may then be used to compensate the temperature effects of the bridge transducers.

Sample Driver for LTC2414/LTC2418 SPI Interface

The LTC2414/LTC2418 have a simple 4-wire serial interface and it is easy to program microprocessors and microcontrollers to control the device.

Figure 49 shows the 4-wire SPI connection between the LTC2414/LTC2418 and a PIC16F84 microcontroller. The sample program for CC5X compiler in Figure 50 can be used to program the PIC16F84 to control the LTC2414/LTC2418. It uses PORT B to interface with the device.

The program begins by declaring variables and allocating four memory locations to store the 32-bit conversion result. In execution, it first initiates the PORT B to the proper SPI configuration and prepares channel address. The LTC2414/LTC2418 is activated by setting the CS low. Then the microcontroller waits until a logic LOW is detected on the data line, signifying end-of-conversion. After a LOW is detected, a subroutine is called to exchange data between the LTC2414/LTC2418 and the microcontroller. The main loop ends by setting \overline{CS} high, ending the data output state.

The performance of the LTC2414/LTC2418 can be verified using the demonstration board DC434A, see Figure 51 for the schematic. This circuit uses the computer's serial port to generate power and the SPI digital signals necessary for starting a conversion and reading the result. It includes a

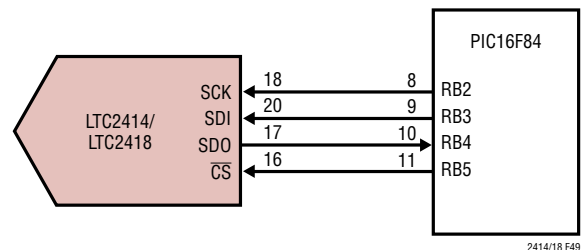

Figure 49. Connecting the LTC2414/LTC2418 to a PIC16F84 MCU Using the SPI Serial Interface

LabVIEW™ application software program (see Figure 52) which graphically captures the conversion results. It can be used to determine noise performance, stability and with an external source linearity. As exemplified in the schematic, the LTC2414/LTC2418 is extremely easy to use. This demonstration board and associated software is available by contacting Linear Technology.

APPLICATIONS INFORMATION

```
// LTC2418 PIC16F84 Interface Example
// Written for CC5X Compiler
// Processor is PIC16F84 running at 10 MHz

#include <16f84.h>
#include <int16cxx.h>
#pragma origin = 0x4
#pragma config |= 0x3fff, WDTE=off,FOSC=HS

// global pin definitions:
#pragma bit rx_pin      @ PORTB.0    //input
#pragma bit tx_pin      @ PORTB.1    //output
#pragma bit sck         @ PORTB.2    //output
#pragma bit sdi         @ PORTB.3    //output
#pragma bit sdo         @ PORTB.4    //input
#pragma bit cs_bar      @ PORTB.5    //output

// Global Variables
uns8 result_3;          // Conversion result MS byte
uns8 result_2;          // ..
uns8 result_1;          // ..
uns8 result_0;          // Conversion result LS byte

void shiftbidir(char nextch);      // function prototype

void main( void)
{
    INTCON=0b00000000;      // no interrupts
    TRISA=0b00000000;      // all PORTA pins outputs
    TRISB=0b00010001;      // according to definitions above

    char channel;          // next channel to send

    while(1)
    {
/* channel bit fields are 7:6, 10 always; 5, EN; 4, SGL; 3, ODD/SIGN; 2:0, ADDR */
        channel = 0b10101000;      // CH0,1 DIFF.
        cs_bar=0;                  // activate ADC

        while(sdo==1)              // test for end of conversion
        {
            // wait if conversion is not complete
        }

        shiftbidir(channel);        // read ADC, send next channel
        cs_bar = 1;                // deactivate ADC

/* At this point global variables result 3,2,1 contain the 24 bit conversion result. Variable result3
contains the corresponding channel information in the following fields:
    bits 7:6, 00 always, 5, EN; 4, SGL; 3, ODD/SIGN; 2:0, ADDR */
    } // end of loop
} // end of main
```

Figure 50. Sample Program in CC5X for PIC16F84

APPLICATIONS INFORMATION

```

////////// Bidirectional Shift Routine for ADC //////////
void shiftbidir(char nextch)
{
    int i;
    for(i=0;i<2;i++)          // send config bits 7:6,
                              // ignore EOC/ and DMY bits

    {
        sdi=nextch.7;        // put data on pin
        nextch = rl(nextch); // get next config bit ready
        sck=1;               // clock high
        sck=0;               // clock low
    }

    for(i=0;i<8;i++)         // send config, read byte 3
    {
        sdi=nextch.7;        // put data on pin
        nextch = rl(nextch); // get next config bit ready
        result_3 = rl(result_3); // get ready to load lsb
        result_3.0 = sdo;    // load lsb
        sck=1;               // clock high
        sck=0;               // clock low
    }

    for(i=0;i<8;i++)         // read byte 2
    {
        result_2 = rl(result_2); // get ready to load lsb
        result_2.0 = sdo;    // load lsb
        sck=1;               // clock high
        sck=0;               // clock low
    }

    for(i=0;i<8;i++)         // read byte 1
    {
        result_1 = rl(result_1); // get ready to load lsb
        result_1.0 = sdo;    // load lsb
        sck=1;               // clock high
        sck=0;               // clock low
    }

    result_0=0;              // ensure bits 7:6 are zero
    for(i=0;i<6;i++)        // read byte 0
    {
        result_0 = rl(result_0); // get ready to load lsb
        result_0.0 = sdo;    // load lsb
        sck=1;               // clock high
        sck=0;               // clock low
    }
}

```

Figure 50. Sample Program in CC5X for PIC16F84 (cont)

APPLICATIONS INFORMATION

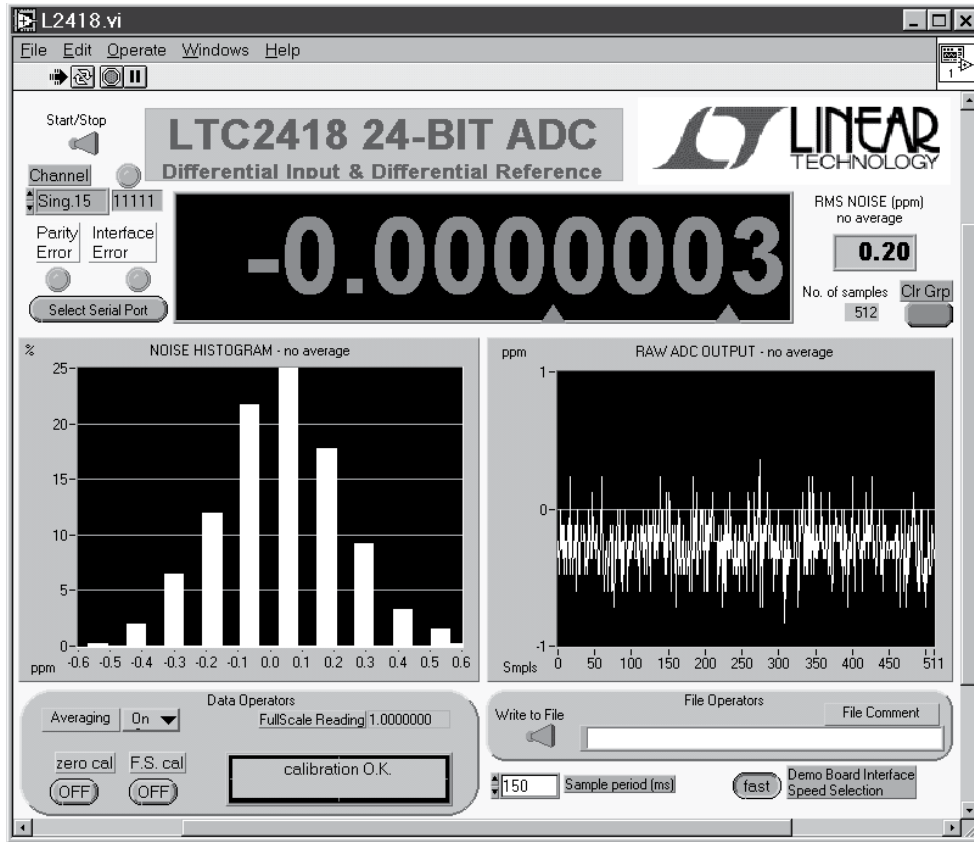

Figure 52. LTC2418 Demo Program Display

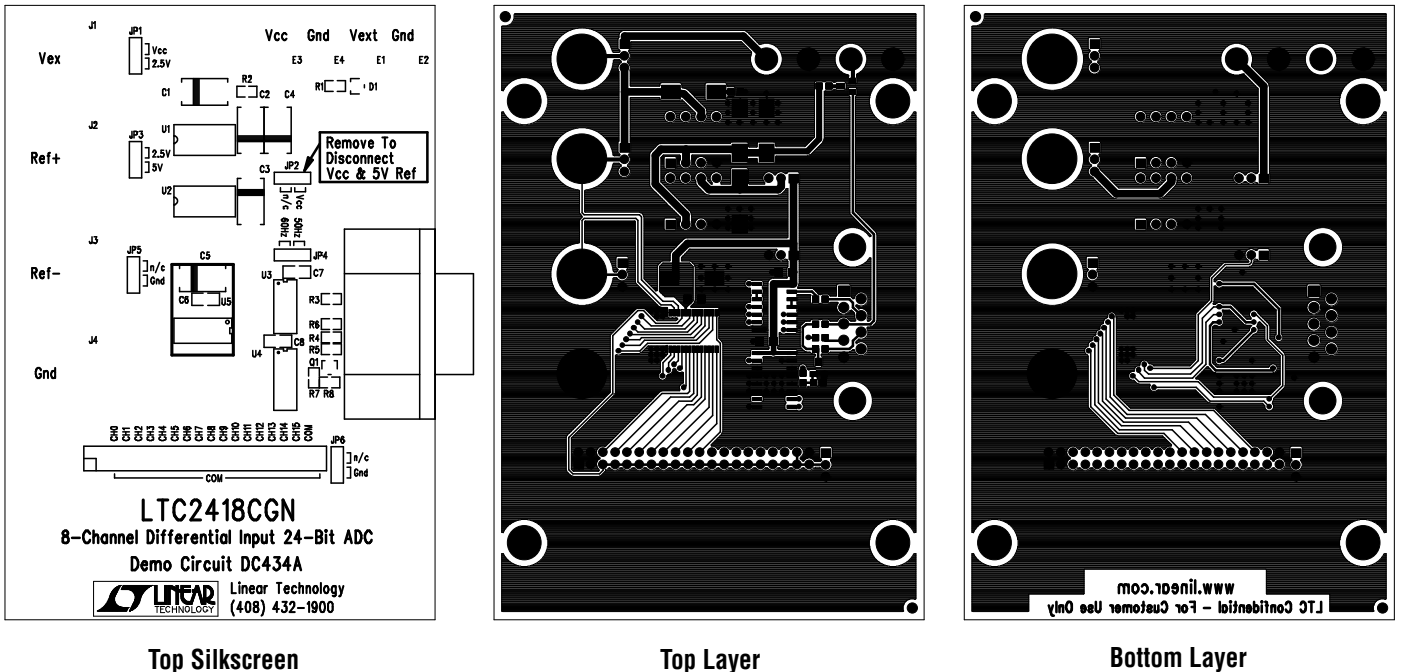
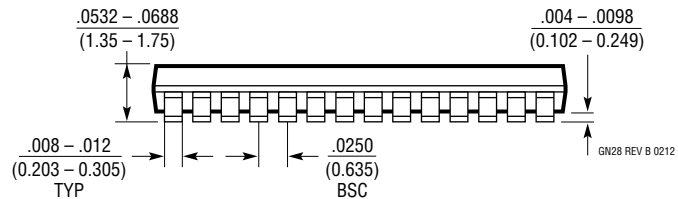
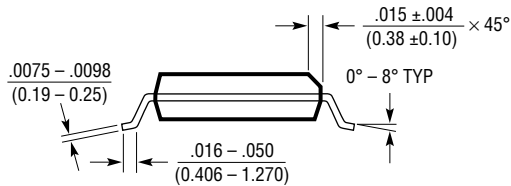
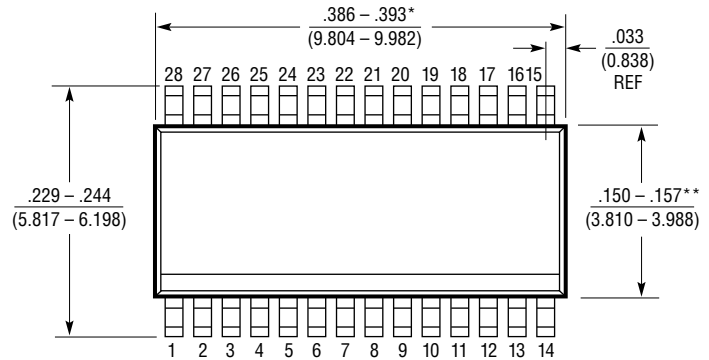
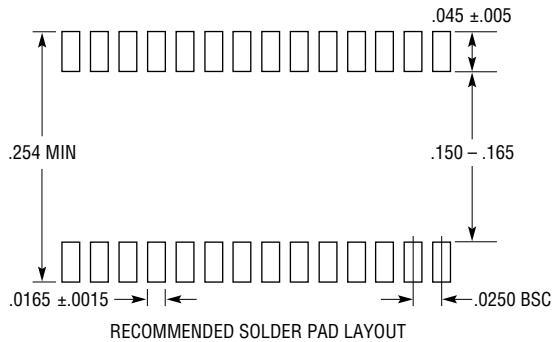

Figure 53. PCB Layout and Film

PACKAGE DESCRIPTION

Please refer to <http://www.linear.com/designtools/packaging/> for the most recent package drawings.

GN Package 28-Lead Plastic SSOP (Narrow .150 Inch) (Reference LTC DWG # 05-08-1641 Rev B)



- NOTE:
1. CONTROLLING DIMENSION: INCHES
 2. DIMENSIONS ARE IN $\frac{\text{INCHES}}{\text{(MILLIMETERS)}}$
 3. DRAWING NOT TO SCALE
 4. PIN 1 CAN BE BEVEL EDGE OR A DIMPLE

*DIMENSION DOES NOT INCLUDE MOLD FLASH. MOLD FLASH SHALL NOT EXCEED $0.006''$ (0.152mm) PER SIDE

**DIMENSION DOES NOT INCLUDE INTERLEAD FLASH. INTERLEAD FLASH SHALL NOT EXCEED $0.010''$ (0.254mm) PER SIDE

REVISION HISTORY (Revision history begins at Rev B)

REV	DATE	DESCRIPTION	PAGE NUMBER
B	08/15	Updated f_{EOSC} maximum to 500KHz and all associated information	5, 9, 30, 31, 32

TYPICAL APPLICATION

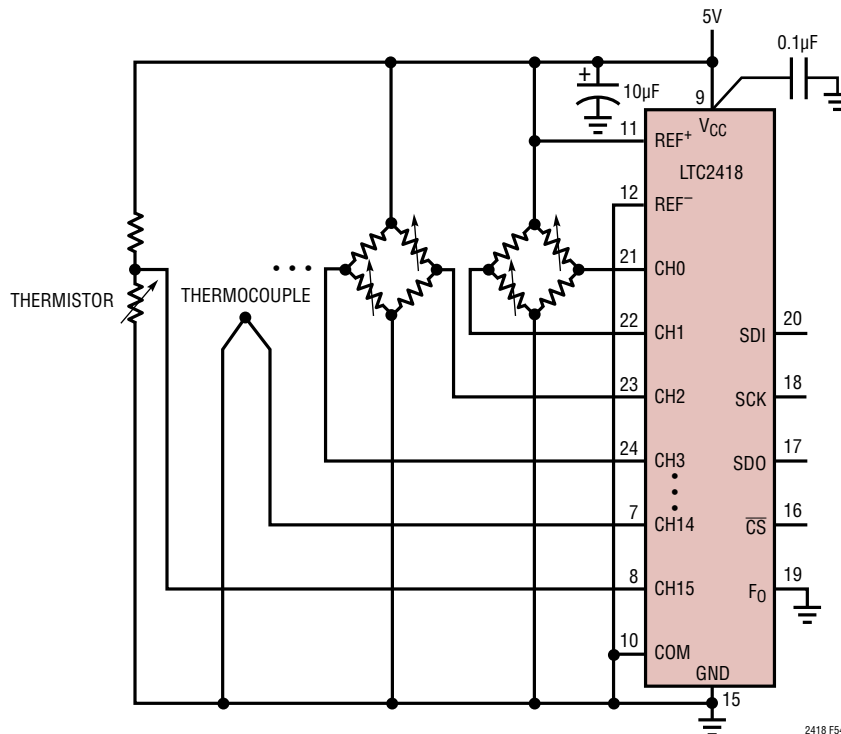



Figure 54. Multichannel Bridge Digitizer and Digital Cold Junction Compensation

RELATED PARTS

PART NUMBER	DESCRIPTION	COMMENTS
LT1019	Precision Bandgap Reference, 2.5V, 5V	3ppm/°C Drift, 0.05% Max Initial Accuracy
LT1025	Micropower Thermocouple Cold Junction Compensator	80µA Supply Current, 0.5°C Initial Accuracy
LTC1050	Precision Chopper Stabilized Op Amp	No External Components 5µV Offset, 1.6µV _{p-p} Noise
LT1236A-5	Precision Bandgap Reference, 5V	0.05% Max Initial Accuracy, 5ppm/°C Drift
LT1460	Micropower Series Reference	0.075% Max Initial Accuracy, 10ppm/°C Max Drift
LTC2400	24-Bit, No Latency ΔΣ ADC in SO-8	0.3ppm Noise, 4ppm INL, 10ppm Total Unadjusted Error, 200µA
LTC2401/LTC2402	1-/2-Channel, 24-Bit, No Latency ΔΣ ADC in MSOP	0.6ppm Noise, 4ppm INL, 10ppm Total Unadjusted Error, 200µA
LTC2404/LTC2408	4-/8-Channel, 24-Bit, No Latency ΔΣ ADC	0.3ppm Noise, 4ppm INL, 10ppm Total Unadjusted Error, 200µA
LTC2410	24-Bit, Fully Differential, No Latency ΔΣ ADC	0.16ppm Noise, 2ppm INL, 3ppm Total Unadjusted Error, 200µA
LTC2411	24-Bit, Fully Differential, No Latency ΔΣ ADC in MSOP	0.3ppm Noise, 2ppm INL, 3ppm Total Unadjusted Error, 200µA
LTC2411-1	24-Bit, Simultaneous 50Hz/60Hz Rejection ΔΣ ADC	0.3ppm Noise, 2ppm INL, Pin Compatible with LTC2411
LTC2413	24-Bit, Fully Differential, No Latency ΔΣ ADC	Simultaneous 50Hz and 60Hz Rejection, 800nV _{RMS} Noise
LTC2415/LTC2415-1	24-Bit, No Latency ΔΣ ADC with 15Hz Output Rate	Pin Compatible with the LTC2410/LTC2413
LTC2420	20-Bit, No Latency ΔΣ ADC in SO-8	1.2ppm Noise, 8ppm INL, Pin Compatible with LTC2400
LTC2424/LTC2428	4-/8-Channel, 20-Bit, No Latency ΔΣ ADC	1.2ppm Noise, Pin Compatible with LTC2404/LTC2408

Looking for pricing, stock, or lifecycle information?

Click below to explore more details on WIN SOURCE:

-  [View LTC2418IGN#PBF on WIN SOURCE](#)
-  [Analog Devices Inc. Information](#)

Optimize Your Supply Chain with WIN SOURCE Solutions

-  Global Sourcing Solution
-  Obsolete Management
-  Cost Control Management
-  Shortage Management
-  Alternative Solution
-  Excess Inventory Management