



**THE DATASHEET OF
LTC2956IMS-1#PBF**



FEATURES

- 1.5V to 36V Supply Input Range
- Adjustable Wake-Up Period: 250ms to 39 Days
- Adjustable Maximum Awake Time
- 0.8 μ A Quiescent Current
- 0.3 μ A Shutdown Current
- Pushbutton Input with Debouncing
- Low Leakage EN Output Allows DC/DC Converter Control (LTC2956-1)
- High Voltage $\overline{\text{EN}}$ Output Drives External P-Channel MOSFET (LTC2956-2)
- $\pm 25\text{kV}$ ESD HBM on $\overline{\text{PB}}$ Input
- 12-Lead 3mm \times 3mm QFN and MSOP Packages

APPLICATIONS

- Heartbeat Timers
- Periodic Wake-Up Control
- Portable and Battery-Powered Equipment
- Intervalometers
- Data Acquisition

DESCRIPTION

The **LTC[®]2956** is a micropower, wide input voltage range, configurable wake-up timer with pushbutton control. It periodically wakes up and turns on a connected system to perform tasks like monitoring temperature or capturing images. After completing the task, the LTC2956 turns the system off to conserve power.

The wake-up timer period can be adjusted from 250ms to 39 days using configuration resistors. The system awake time can be controlled by the input pulse at the $\overline{\text{SLEEP}}$ pin or adjusted by the capacitor at the ONMAX pin. The LTC2956 operates over a wide supply input range from 1.5V to 36V. The low 800nA quiescent current suits battery powered applications.

The pushbutton input allows the user to shutdown, turn on or reset the wake-up timer. With the timer in shutdown, the quiescent current drops to 300nA. The LTC2956 also provides three status outputs to indicate mode transitions and pushbutton events. Two versions are available for applications requiring either positive or negative enable polarities.

LT, LT, LTC, LTM, Linear Technology and the Linear logo are registered trademarks and PowerPath and ThinSOT are trademarks of Linear Technology Corporation. All other trademarks are the property of their respective owners.

TYPICAL APPLICATION

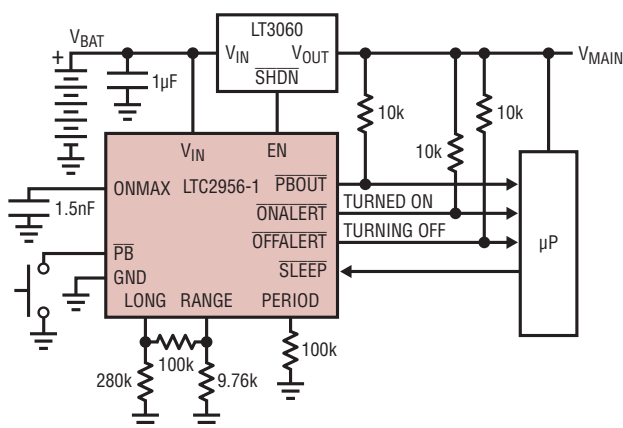

$t_{\text{LONG}} = 1\text{s}$, $t_{\text{ONMAX}} = 20\text{ms}$, $t_{\text{PERIOD}} = 250\text{ms}$

2956 TA01a

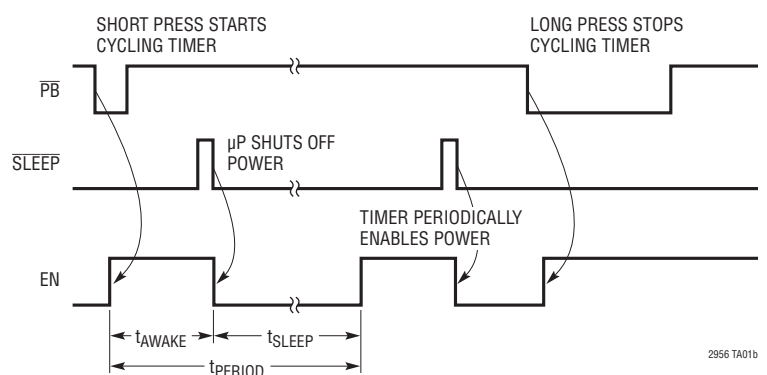

2956 TA01b

ABSOLUTE MAXIMUM RATINGS

(Note 1)

V_{IN} (Note 3).....	-0.3V to 40V
Input Voltages:	
\overline{PB}	-40V to 40V
SLEEP	-0.3V to 6V
LONG, PERIOD, RANGE, ONMAX	0.3V to 3.6V
Output Voltages:	
$\overline{ONALERT}$, \overline{PABOUT} , $\overline{OFFALERT}$	-0.3V to 6V
EN/ \overline{EN}	-0.3V to 40V

Operating Temperature Range:

LTC2956C 0°C to 70°C

LTC2956I -40°C to 85°C

Storage Temperature Range:

QFN Package -65°C to 150°C

MSOP Package -65°C to 150°C

Lead Temperature (Soldering, 10 sec):

MSOP Package 300°C

PIN CONFIGURATION

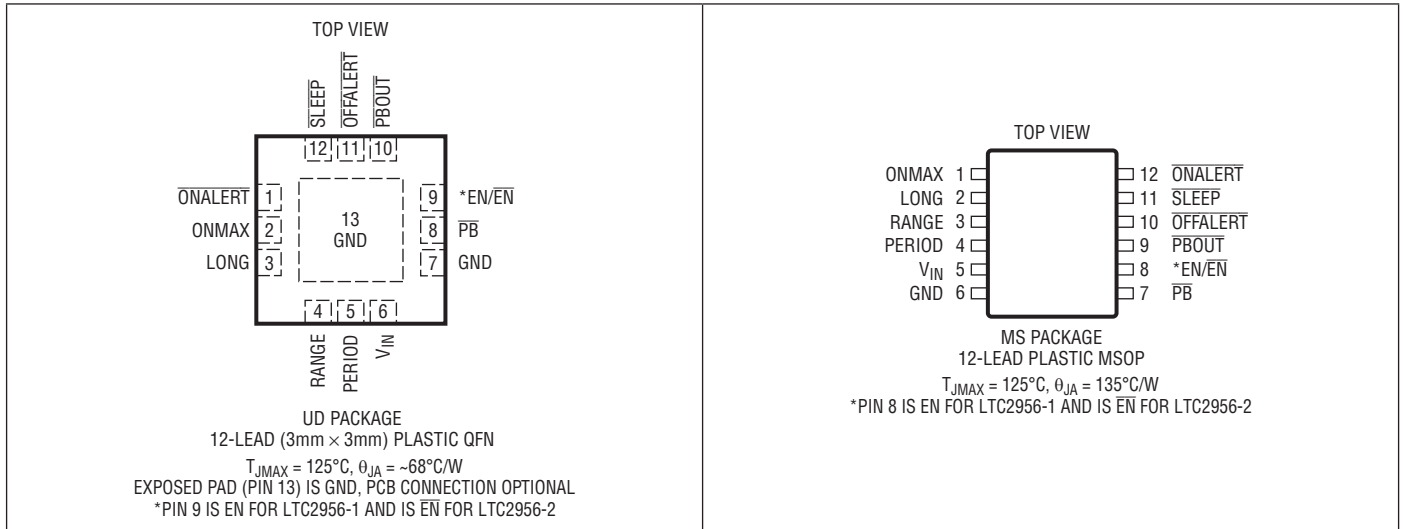

ORDER INFORMATION

LEAD FREE FINISH	TAPE AND REEL	PART MARKING*	PACKAGE DESCRIPTION	TEMPERATURE RANGE
LTC2956CUD-1#PBF	LTC2956CUD-1#TRPBF	LGNH	12-Lead (3mm × 3mm) Plastic QFN	0°C to 70°C
LTC2956CUD-2#PBF	LTC2956CUD-2#TRPBF	LGTC	12-Lead (3mm × 3mm) Plastic QFN	0°C to 70°C
LTC2956IUD-1#PBF	LTC2956IUD-1#TRPBF	LGNH	12-Lead (3mm × 3mm) Plastic QFN	-40°C to 85°C
LTC2956IUD-2#PBF	LTC2956IUD-2#TRPBF	LGTC	12-Lead (3mm × 3mm) Plastic QFN	-40°C to 85°C
LTC2956CMS-1#PBF	LTC2956CMS-1#TRPBF	29561	12-Lead Plastic MSOP	0°C to 70°C
LTC2956CMS-2#PBF	LTC2956CMS-2#TRPBF	29562	12-Lead Plastic MSOP	0°C to 70°C
LTC2956IMS-1#PBF	LTC2956IMS-1#TRPBF	29561	12-Lead Plastic MSOP	-40°C to 85°C
LTC2956IMS-2#PBF	LTC2956IMS-2#TRPBF	29562	12-Lead Plastic MSOP	-40°C to 85°C

Consult LTC Marketing for parts specified with wider operating temperature ranges. *The temperature grade is identified by a label on the shipping container. Consult LTC Marketing for information on nonstandard lead based finish parts.

For more information on lead free part marking, go to: <http://www.linear.com/leadfree/>

For more information on tape and reel specifications, go to: <http://www.linear.com/tapeandreeel/>

ELECTRICAL CHARACTERISTICS

The ● denotes the specifications which apply over the full operating temperature range, otherwise specifications are at $T_A = 25^\circ\text{C}$. $V_{IN} = 3.3\text{V}$, $R_{COM} = 100\text{k}$ unless otherwise noted. (Note 2)

SYMBOL	PARAMETER	CONDITIONS		MIN	TYP	MAX	UNITS
V_{IN}	Supply Voltage Range		●	1.5		36	V
I_{IN}	V_{IN} Supply Current	Awake State, $\overline{\text{PB}}$ Hi Sleep State, $\overline{\text{PB}}$ Hi Off State, $\overline{\text{PB}}$ Hi	● ● ●		3 0.8 0.3	10 3 1	μA μA μA
V_{UVL}	V_{IN} Undervoltage Lockout	V_{IN} Rising	●	1.08	1.24	1.4	V
$V_{UVL(HYST)}$	V_{IN} Undervoltage Lockout Hysteresis				100		mV

Wake-Up Timer

t_{PERIOD}	Period Accuracy	$R_{PERIOD} = 100\text{k}\Omega$	●	237	250	263	ms
R_{PERIOD}	Period-Setting Resistor Range		●	32.4		324	$\text{k}\Omega$

Timing (Refer to Timing Diagram)

t_{SLEEP_MIN}	Minimum Sleep Duration		●	76	128	180	ms
t_{AWAKE_MIN}	Minimum Awake Time		●	4	8	12	ms
t_{ONMAX}	Maximum Awake Time	$\overline{\text{SLEEP}} = 0\text{V}$, $C_{ONMAX} = 3900\text{pF}$	●	32	52	72	ms
t_{DB}	$\overline{\text{PB}}$ Debounce Time	$\overline{\text{PB}}$ Goes Low \rightarrow EN Goes High	●	19	32	45	ms
$t_{PD(SLEEP)}$	$\overline{\text{SLEEP}}$ Propagation Delay	$\overline{\text{SLEEP}} \rightarrow$ EN Transitions	●		2	4	ms
t_{PBOUT_FIRST}	Width of First $\overline{\text{PBOUT}}$ Pulse After Entering Awake State		●	76	128	180	ms
t_{LONG}	Long Power Down Time	$R_{LONG} = 9.76\text{k}$, $R_{COM} = 100\text{k}$ $R_{LONG} = \text{Open}$, $R_{COM} = 100\text{k}$	● ●	76 9.83	128 16.4	180 22.9	ms s
t_{OFF}	$\overline{\text{OFFALERT}}$ Pulse Width	$\overline{\text{PB}} = 2\text{V}$	●	0.6	1	1.4	s

Input Pins: $\overline{\text{PB}}$, ONMAX, SLEEP

$V_{\overline{\text{PB}}(\text{MIN},\text{MAX})}$	$\overline{\text{PB}}$ Voltage Range		●	-36		36	V
$I_{\overline{\text{PB}}}$	$\overline{\text{PB}}$ Input Current	$\overline{\text{PB}} = 0\text{V}$ $\overline{\text{PB}} = -36\text{V}$	●	-1	-4	-8 -400	μA μA
$V_{\overline{\text{PB}}(\text{TH})}$	$\overline{\text{PB}}$ Input Threshold	$\overline{\text{PB}}$ Falling	●	0.5	0.9	1.5	V
$V_{\overline{\text{PB}}(\text{HYST})}$	$\overline{\text{PB}}$ Input Hysteresis				0.7		V
$V_{\overline{\text{PB}}(\text{OC})}$	$\overline{\text{PB}}$ Open Circuit Voltage	$I_{\overline{\text{PB}}} = 0\mu\text{A}$, $-1\mu\text{A}$	●	1.5			V
$R_{\overline{\text{PB}}}$	$\overline{\text{PB}}$ Pull-Up Resistance		●	0.45	0.9	1.35	$\text{M}\Omega$
$V_{\overline{\text{SLEEP}}(\text{TH})}$	$\overline{\text{SLEEP}}$ Input Threshold Voltage	$\overline{\text{SLEEP}}$ Falling	●	0.7	1	1.3	V
$V_{\overline{\text{SLEEP}}(\text{HYST})}$	$\overline{\text{SLEEP}}$ Input Hysteresis				80		mV
$I_{\overline{\text{SLEEP}}}$	$\overline{\text{SLEEP}}$ Leakage Current	$\overline{\text{SLEEP}} = 1\text{V}$	●		0	± 100	nA
$V_{\text{ONMAX}(\text{TH})}$	ONMAX Input Threshold Voltage	ONMAX Rising	●	0.6	1	1.5	V
I_{ONMAX}	ONMAX Pull-Up Current	ONMAX = 0V	●	-1.1	-2	-2.8	μA

ELECTRICAL CHARACTERISTICS

The ● denotes the specifications which apply over the full operating temperature range, otherwise specifications are at $T_A = 25^\circ\text{C}$. $V_{IN} = 3.3\text{V}$, $R_{COM} = 100\text{k}$ unless otherwise noted. (Note 2)

SYMBOL	PARAMETER	CONDITIONS	MIN	TYP	MAX	UNITS
Output Pins: EN/$\overline{\text{EN}}$, P$\overline{\text{BOUT}}$, ONALERT, OFFALERT, PERIOD, RANGE, LONG						
$V_{\text{EN}(\text{VOH})}$	EN Voltage Output High (LTC2956-1)	$I = 0\mu\text{A}, -1\mu\text{A}$	● 1.5			V
$V_{\overline{\text{EN}}(\text{VOH})}$	$\overline{\text{EN}}$ Voltage Output High (LTC2956-2)	$I = 0\mu\text{A}, -1\mu\text{A}$	● $V_{\text{IN}} - 1.5$		V_{IN}	V
$R_{\text{EN}/\overline{\text{EN}}}$	EN/ $\overline{\text{EN}}$ Pull-Up Resistance		● 0.45	0.9	1.35	M Ω
V_{OL}	Output Low Voltage (EN/ $\overline{\text{EN}}$)	$I = 1\text{mA}$	●		0.4	V
	Output Low Voltage (ONALERT, P $\overline{\text{BOUT}}$)	$I = 3\text{mA}$	●		0.4	V
	Output Low Voltage (OFFALERT)	$I = 6\text{mA}$	●		0.4	V
I_{OH}	Input Leakage Current (RANGE, LONG)	$V = 1.5\text{V}$	●		± 100	nA
	Leakage Current (P $\overline{\text{BOUT}}$, ONALERT, OFFALERT)	$V = 5\text{V}$	●		± 100	nA
V_{PERIOD}	PERIOD Open Circuit Voltage	$I = -1\mu\text{A}$	● 0.3	0.4	0.5	V

Note 1: Stresses beyond those listed under Absolute Maximum Ratings may cause permanent damage to the device. Exposure to any Absolute Maximum Rating condition for extended periods may affect device reliability and lifetime.

Note 2: All currents into device pins are positive; all currents out of device pins are negative; all voltages are referenced to GND unless otherwise noted.

Note 3: A substrate diode limits the V_{IN} pin to a minimum of -0.3V with respect to GND. This pin may go below -0.3V with current limited to less than 50mA .

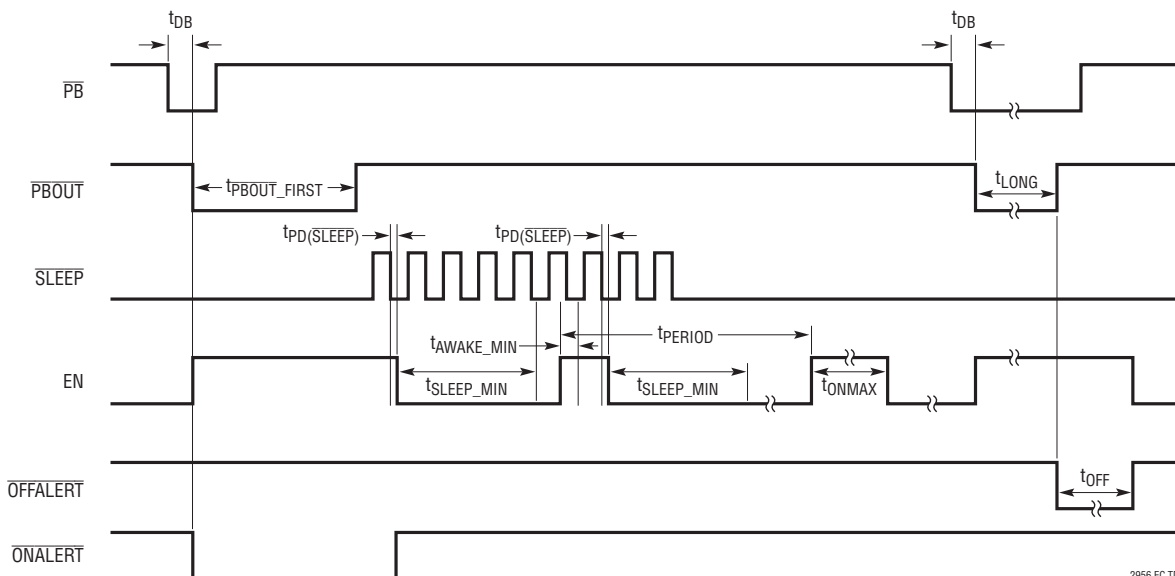

Timing Diagram

2956 EC TD

TYPICAL PERFORMANCE CHARACTERISTICS

Supply Current vs Temperature

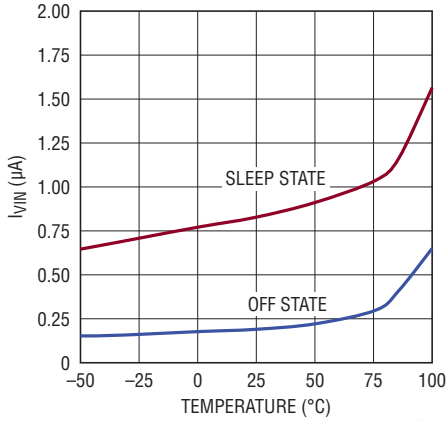

Supply Current vs Supply Voltage

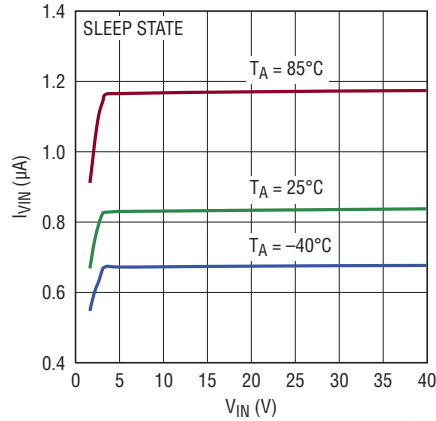

Undervoltage Lockout vs Temperature

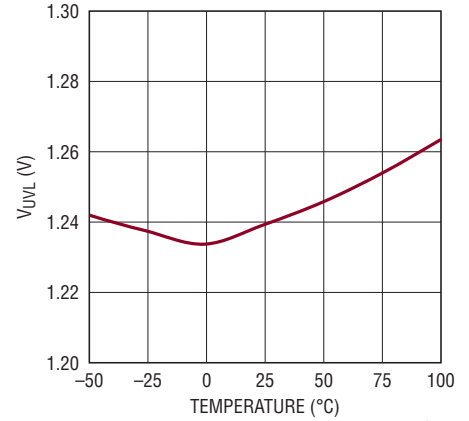

Wake-Up Period vs PERIOD Resistance

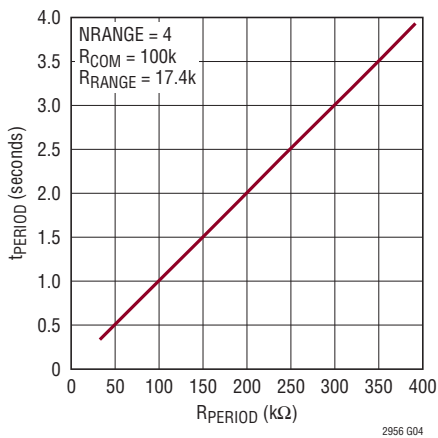

Wake-Up Period vs Temperature

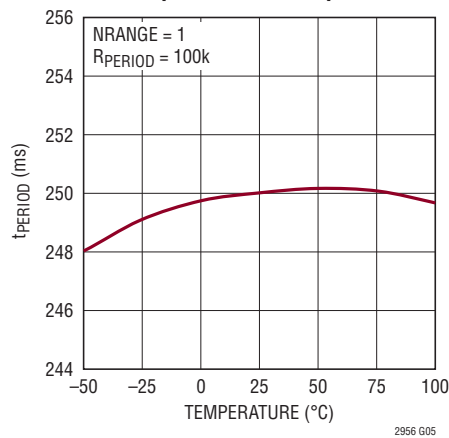

Maximum Awake Time vs C_ONMAX

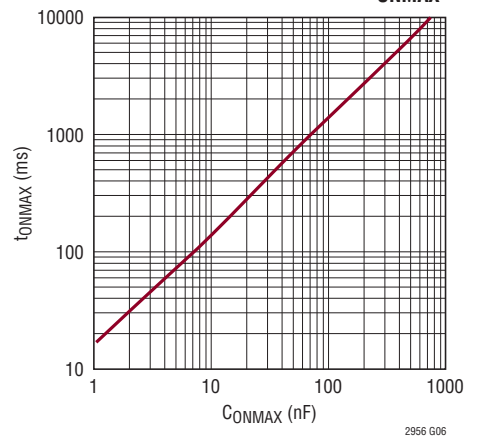

Maximum Awake Time vs Temperature

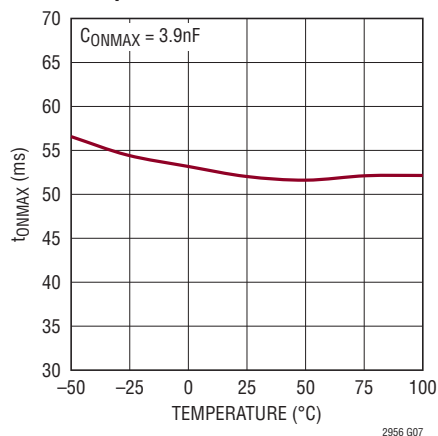

EN Output High Voltage vs Supply Voltage

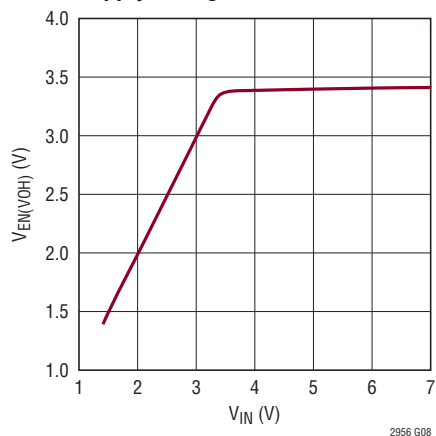

EN Output High Voltage vs Temperature

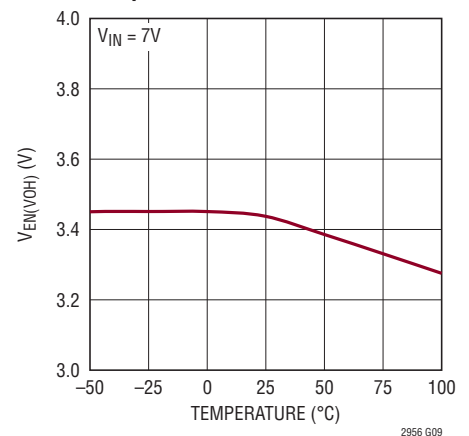

TYPICAL PERFORMANCE CHARACTERISTICS

EN/ $\overline{\text{EN}}$ Output Low Voltage vs Temperature

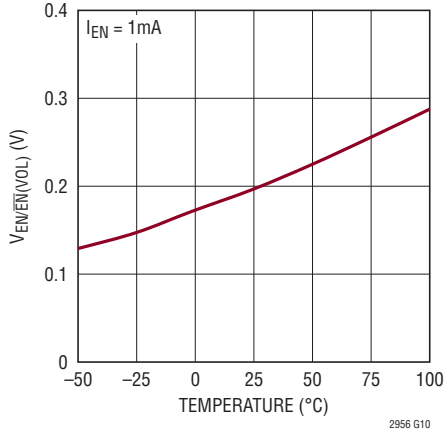

EN/ $\overline{\text{EN}}$ Output Low Voltage vs Current

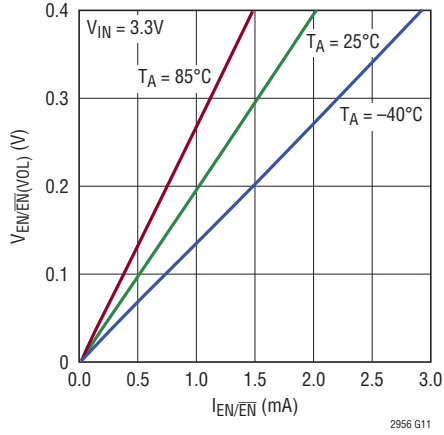

PB Debounce Time vs Temperature

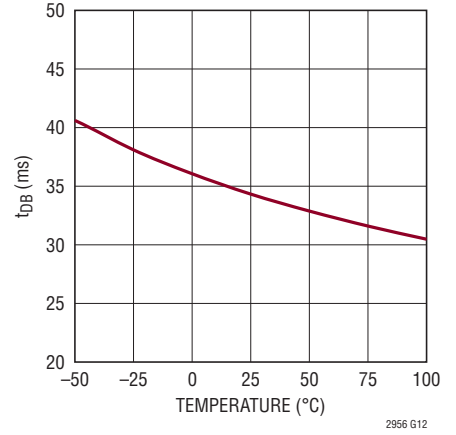

PB Input Current vs PB Voltage

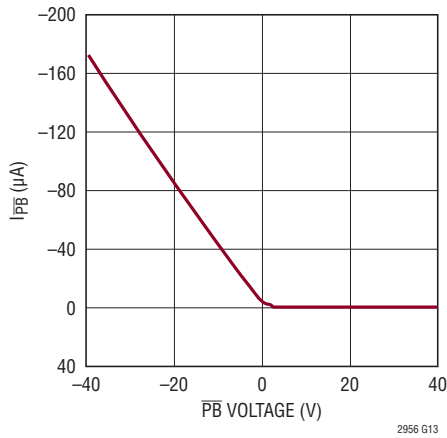

PB Voltage vs External PB Resistance to Ground

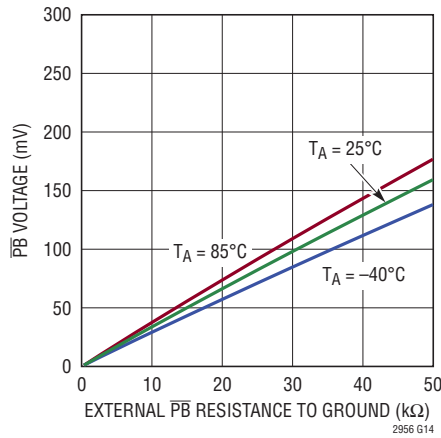

ONALERT Output Low Voltage vs Current

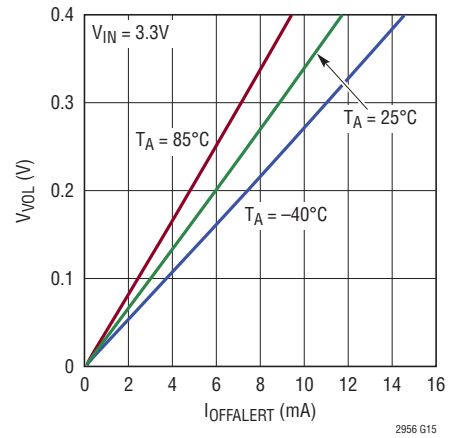

PIN FUNCTIONS

EN: Enable Output (LTC2956-1). EN is an active high output to control the turn-on/off of a load. Connect this pin to the RUN or SHUTDOWN pin of a voltage regulator. The LTC2956-1 pulls EN high through an internal 900k resistor and Schottky diode to a 3.3V regulated supply when the pushbutton is pressed or when the wake-up period is reached. EN pulls low during the Sleep state. This pin may be left open if unused.

$\overline{\text{EN}}$: Inverted Enable Output (LTC2956-2). $\overline{\text{EN}}$ is an active low output to control the turn-on/off of the system power. It may drive a voltage regulator's active low enable input, or it may drive the gate of a P-channel MOSFET directly. In the Sleep state, the LTC2956-2 pulls this pin to V_{IN} through an internal 900k resistor. The LTC2956-2 pulls $\overline{\text{EN}}$ to GND when the pushbutton is pressed or when the wake-up timer period is reached. This pin may be left open if unused.

Exposed Pad (QFN only): Exposed Pad. Leave open or connect to device ground.

GND: Device Ground.

LONG: Long Power Down Time Selection Input. Connect a resistor from the LONG pin to GND. Together with the 100k resistor between the RANGE and LONG pin, this adjusts the t_{LONG} power down time (t_{LONG} can be adjusted from 128ms to 16.4s). If SLEEP is pulled high or PB is pulled low longer than t_{LONG} , the part goes into SHUTDOWN mode. See Applications Information for details.

OFFALERT: Off Alert Open Drain Output. The LTC2956 pulls this pin low for 1 second (t_{OFF}) whenever the part goes from RUN mode to SHUTDOWN mode. This pin can be connected to the interrupt input of the system (with a pull-up resistor to the system supply) to alert the system before shutdown. It can also be used to drive an external LED to give a visual indication. This pin may be left open if unused.

ONALERT: On Alert Open Drain Output. The LTC2956 pulls this pin low whenever the part goes from SHUTDOWN

mode to RUN mode. The pin stays low while the EN pin is high and it can be used as an input to the system to request for initial boot up routine. This pin may be left open if unused.

ONMAX: Maximum Awake Timer Capacitor Input. Connect a capacitor from this pin to GND adjust the maximum allowed awake time (t_{ONMAX}) at 13.3ms/nF. If this pin is left floating, the minimum awake time is limited to 8ms. Tie this pin to GND if unused.

PB: Pushbutton Input. This is an active low input with a 900k Ω pull-up to an internal 3.3V regulated supply. Connect one terminal of the pushbutton switch to this pin and connect the other terminal of a pushbutton switch to GND. The pin may be left open if unused.

PBOUT: Debounced Pushbutton Open Drain Output. This pin follows the debounced PB input. This pin may be left open if unused.

PERIOD: Wake-Up Timer Adjust Input. Connect a resistor from the PERIOD pin to GND to adjust the wake-up timer period. See the Application Section for resistor selection information.

RANGE: Wake-Up Timer Range Selection Input. Connect a resistor from the RANGE pin to GND and a 100k resistor between the RANGE and LONG pin to choose the wake-up timer period range setting. See Application Section for information about the resistor selection.

SLEEP: SLEEP Input. The SLEEP input is active during RUN mode. In the Awake state, a falling edge at the SLEEP input will pull EN low ($\overline{\text{EN}}$ high) and put the system into the Sleep state. If the SLEEP input goes high during the Sleep state, the LTC2956 re-enters the Awake state and pulls EN high ($\overline{\text{EN}}$ low) to turn on the system. Holding SLEEP high for more than t_{LONG} will force the system into the SHUTDOWN mode. If unused, tie SLEEP to GND, and use the ONMAX pin to control the awake time.

V_{IN}: Power Supply Input (1.5V to 36V).

BLOCK DIAGRAM

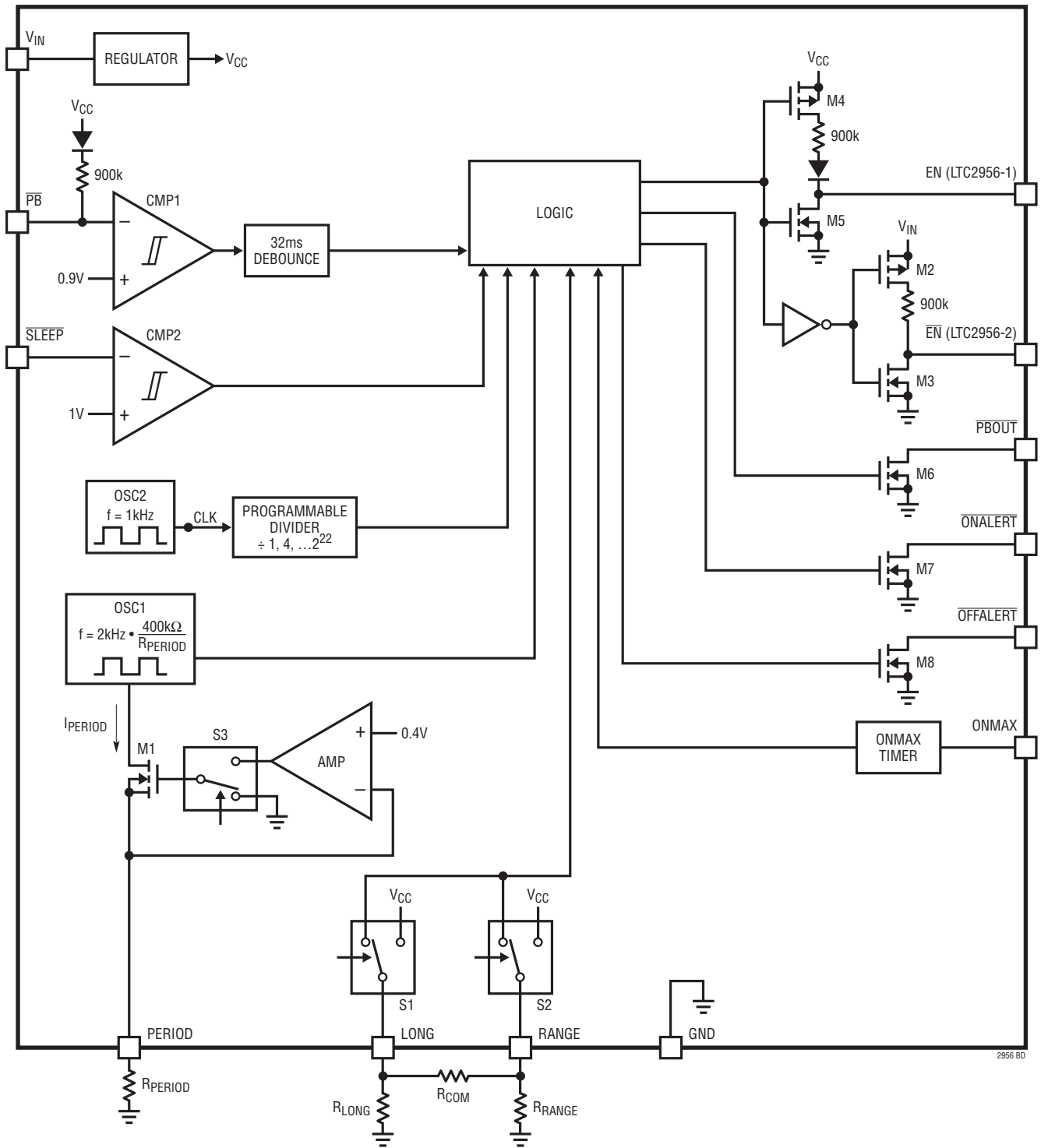

2956 BD

OPERATION

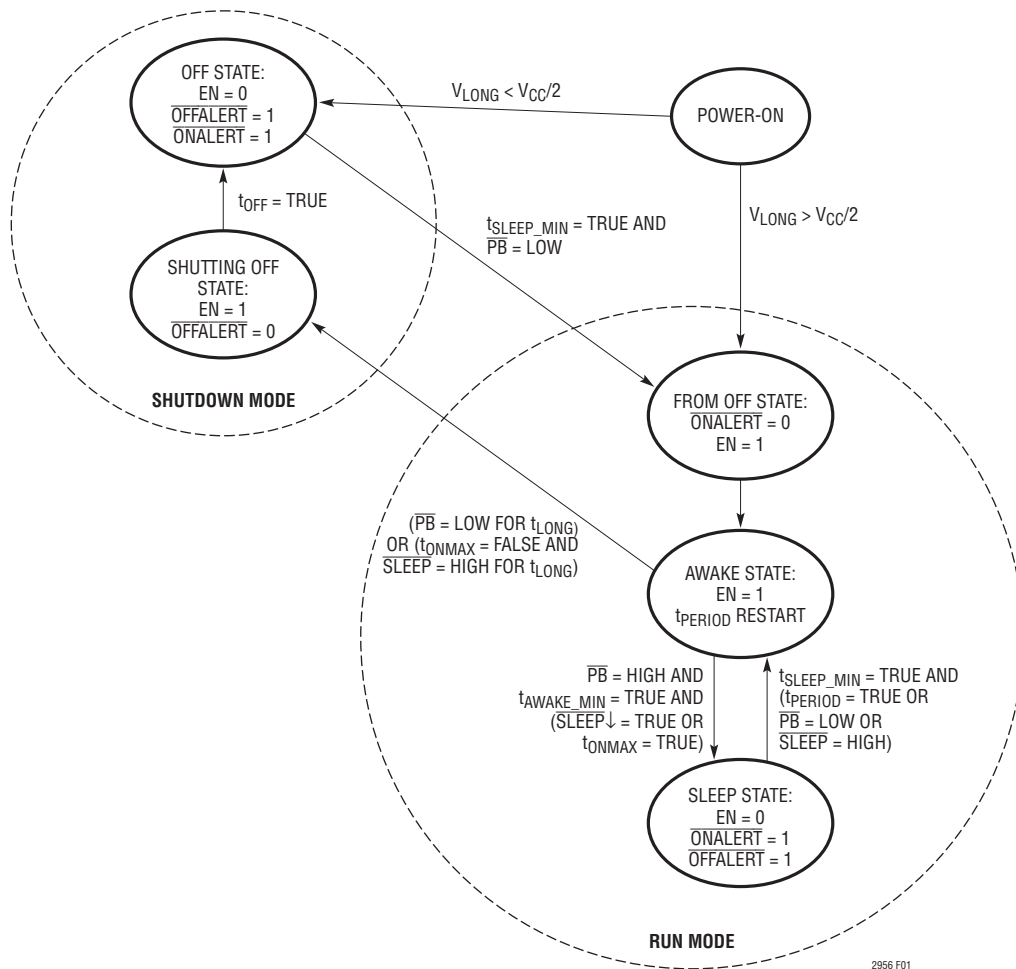

Figure 1. Functional State Diagram

2956 F01

OPERATION

OVERVIEW

The LTC2956 is a micropower, highly configurable wake-up timer with pushbutton control. It controls power to a connected system to allow that system to perform a periodic task. After completing the task, the LTC2956 turns the system off to conserve power. Figure 1 shows a simplified state diagram of the LTC2956. The LTC2956 has two modes of operation: RUN mode and SHUTDOWN mode.

In RUN mode, the LTC2956 cycles between the Awake state and the Sleep state with a period of t_{PERIOD} . During the Awake state the EN pin is pulled high to turn the system on, and the t_{ONMAX} timer runs. The LTC2956 exits the Awake state when a falling edge is detected on the $\overline{\text{SLEEP}}$ pin or if the t_{ONMAX} timer expires. The LTC2956 ignores any $\overline{\text{SLEEP}}$ pin transitions for $t_{\text{AWAKE_MIN}}$ (typically 8ms) after entering the Awake state to ensure that the minimum on time is met.

In the Sleep state, the EN output stays low, and the connected system turns off. The LTC2956 returns to the Awake state if the t_{PERIOD} time is reached, if the pushbutton (connected to the $\overline{\text{PB}}$ pin) is pressed, or if a logic high is detected on the $\overline{\text{SLEEP}}$ pin. The minimum duration for the Sleep state is $t_{\text{SLEEP_MIN}}$ (typically 128ms), and any input or t_{PERIOD} transitions during this time are ignored in order to allow the system supply to sufficiently discharge.

SHUTDOWN mode is a very low power mode with the timer disabled, entered through a long press of the pushbutton or a long high pulse at the $\overline{\text{SLEEP}}$ input. This is useful for products that are shipped with their batteries installed. A short press on the pushbutton brings the LTC2956 back into RUN mode. The LTC2956 can be configured to start in either RUN or SHUTDOWN mode at power-up via the LONG pin (see the Applications Information section).

SHUTDOWN mode consists of the Shutting Off state and the Off state. The Shutting Off state occurs first during the transition from RUN mode to SHUTDOWN mode, and allows time for the system to perform any shutdown tasks before the EN pin goes low in the Off state. This state is indicated by the $\overline{\text{OFFALERT}}$ pin pulling low and lasts for

t_{OFF} (typically 1s). Once the t_{OFF} timer completes, the LTC2956 transitions to the Off state, the EN pin is pulled low and all timers are disabled, and the quiescent current drops to about 0.3 μ A.

When the LTC2956 returns to the RUN mode from the SHUTDOWN mode, it first enters the From Off state to allow the connected system to run initialization tasks. This is indicated by the $\overline{\text{ONALERT}}$ pin pulling low. The EN pin is pulled high to turn the connected system on.

The LTC2956 turns the connected system on and off via the EN pin. The LTC2956-1's active high EN pin can be connected to the system supply RUN pin while the LTC2956-2's active low $\overline{\text{EN}}$ pin can directly control the system supply through a P-channel MOSFET.

The wake-up timer period can be adjusted from 250ms to 39 days via resistors at the PERIOD and RANGE pins. The timing of the long pushbutton press and $\overline{\text{SLEEP}}$ pulse can be adjusted via resistors connected to the LONG pin. To minimize the quiescent current, the RANGE, LONG, and PERIOD pins are biased only when the LTC2956 performs a configuration cycle.

Timer configuration is performed once every 66 seconds while the part is operating in RUN mode, and it is also performed following power-up and whenever the LTC2956 exits the SHUTDOWN mode. During configuration, the LTC2956 biases and reads the voltages at the RANGE and LONG pins that are defined by external configuration resistors. See Configuration section for more details.

Operations with $\overline{\text{SLEEP}}$ Tied Low (Passive System)

The LTC2956 is designed to control the power of both active and passive systems. With a passive system where the $\overline{\text{SLEEP}}$ pin is not managed by a microcontroller, the $\overline{\text{SLEEP}}$ pin can be tied low and a capacitor connected to the ONMAX pin determines the awake time. The minimum t_{ONMAX} must be longer than the maximum expected time the system takes to complete its routine tasks.

OPERATION

Figure 2 shows the timing waveform of a passive system application using a LTC2956-1. When the t_{PERIOD} time is reached, the LTC2956 enters the Awake state and pulls the EN output high to turn on the system. The t_{PERIOD} timer restarts and the t_{ONMAX} timer starts running. Once the t_{ONMAX} timer expires, the LTC2956 re-enters the Sleep state and pulls the EN output low. The t_{PERIOD} timer continues to run until the next period is reached.

Note that the t_{PERIOD} timer is a digital counter inside the LTC2956, but it is illustrated as a simple ramp in all the figures in this data sheet. The t_{ONMAX} timer counts using both the analog ramp on the ONMAX pin as well as an internal digital counter. It is also represented as a simple ramp in all the figures in this data sheet.

The LTC2956 ignores the t_{ONMAX} timer during the first 8ms ($t_{\text{AWAKE_MIN}}$) after the EN output is pulled high which limits the minimum t_{AWAKE} time to $t_{\text{AWAKE_MIN}}$ (8ms typical).

Operations with $\overline{\text{SLEEP}}$ Toggling (Active System)

With an active system, i.e. microprocessor based, the system can toggle the $\overline{\text{SLEEP}}$ pin to terminate the Awake state immediately after it has completed a routine/periodic task. The LTC2956 will pull the EN output low to turn off

the system and enter the Sleep state. This keeps the awake time to a minimum and helps minimize the drain on the system battery.

Figure 3 shows the timing waveform for an active system application. When the t_{PERIOD} time is reached, the LTC2956-1 enters the Awake state and pulls the EN output high to turn on the system. The t_{PERIOD} timer resets, and the t_{ONMAX} timer start running. When the system has completed its periodic task, the LTC2956 is commanded to re-enter the Sleep state by pulling the $\overline{\text{SLEEP}}$ pin low.

The LTC2956 ignores both the $\overline{\text{SLEEP}}$ pin and t_{ONMAX} timer during the $t_{\text{AWAKE_MIN}}$ interval (8ms typical) just after EN goes high in order to guarantee that the system has stabilized. If the system completes its task before $t_{\text{AWAKE_MIN}}$ is reached, it can toggle $\overline{\text{SLEEP}}$ continuously until the LTC2956 responds by pulling EN low (Figure 4). If the system only toggles the $\overline{\text{SLEEP}}$ pin during $t_{\text{AWAKE_MIN}}$, the LTC2956 will not respond to the $\overline{\text{SLEEP}}$ pin's falling edge(s) and remains in the Awake state until the t_{ONMAX} timer expires.

If $\overline{\text{SLEEP}}$ is held low during the entire Awake state period, the t_{ONMAX} timer will timeout (Figure 2) forcing the

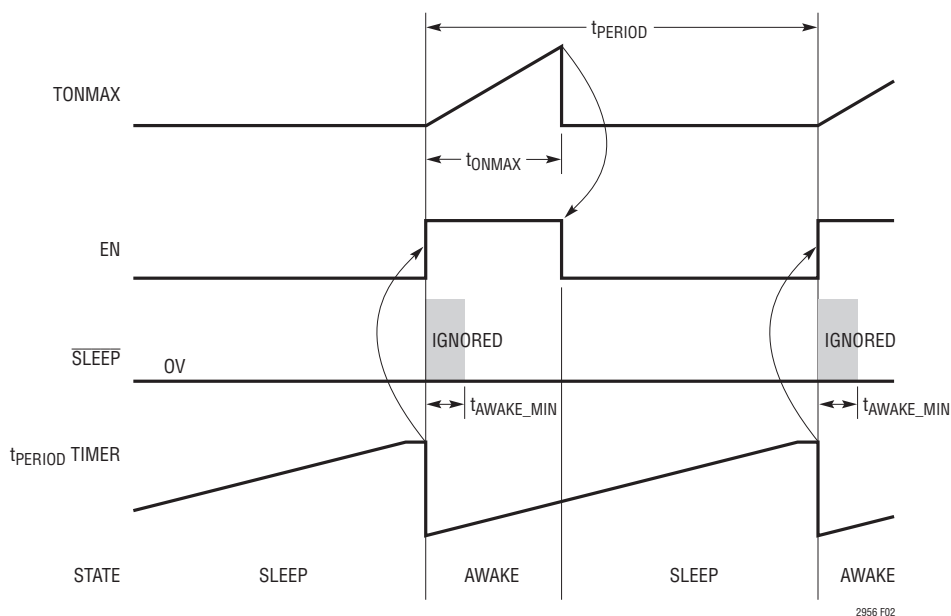

Figure 2. Operation with $\overline{\text{SLEEP}}$ Tied Low (Passive System)

OPERATION

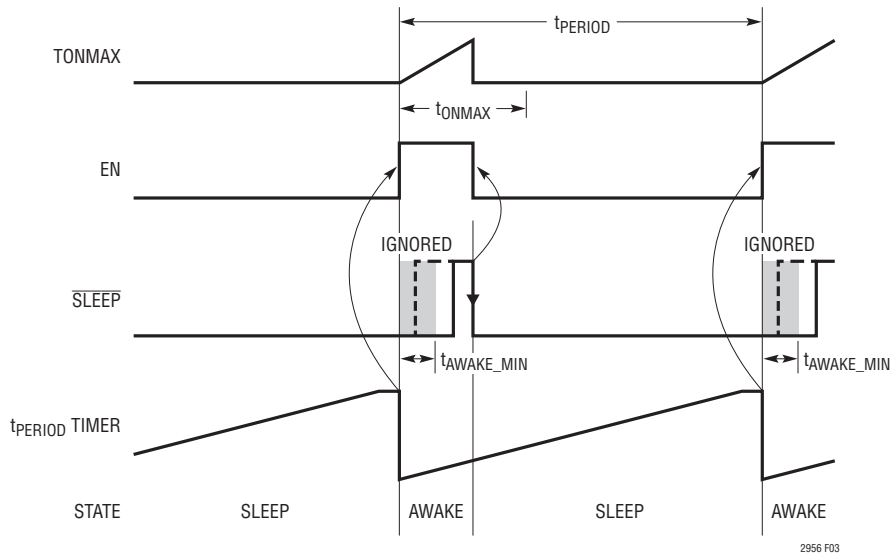

Figure 3. Operation with $\overline{\text{SLEEP}}$ Toggling (Active System)

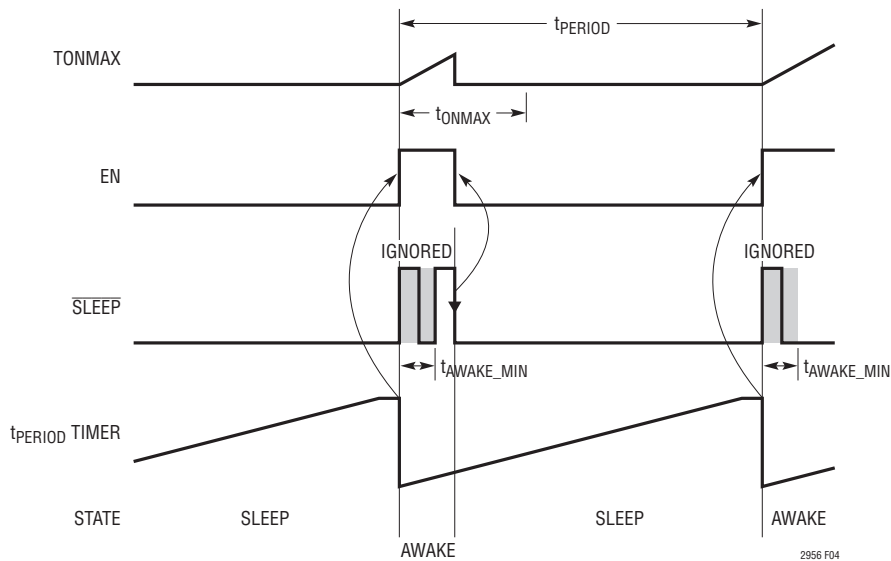

Figure 4. Toggling $\overline{\text{SLEEP}}$ Continuously to Enter Sleep State

LTC2956-1 back into the Sleep state. This t_{ONMAX} watchdog timer feature is particularly useful in applications where an active system’s software/firmware might encounter a stuck state or infinite loop thus preventing the system from excessively discharging the battery.

Power Up

The LTC2956 can be configured to power up automatically in either RUN or SHUTDOWN mode. This is done through

the resistive divider setting at LONG pin. If the voltage on the LONG pin is configured to be greater than $V_{CC}/2$ (see Table 2), the LTC2956 enters the RUN mode (see Figure 5). If the voltage on the LONG pin is configured to be less than $V_{CC}/2$, the LTC2956 enters the SHUTDOWN mode. In SHUTDOWN mode, a press of the push button is needed to transition the wake-up timer to the Awake state and start the t_{PERIOD} timer (Figure 6). $t_{CONFIGURATION}$ is the system configuration time. It can last between 0.1s to 1s.

OPERATION

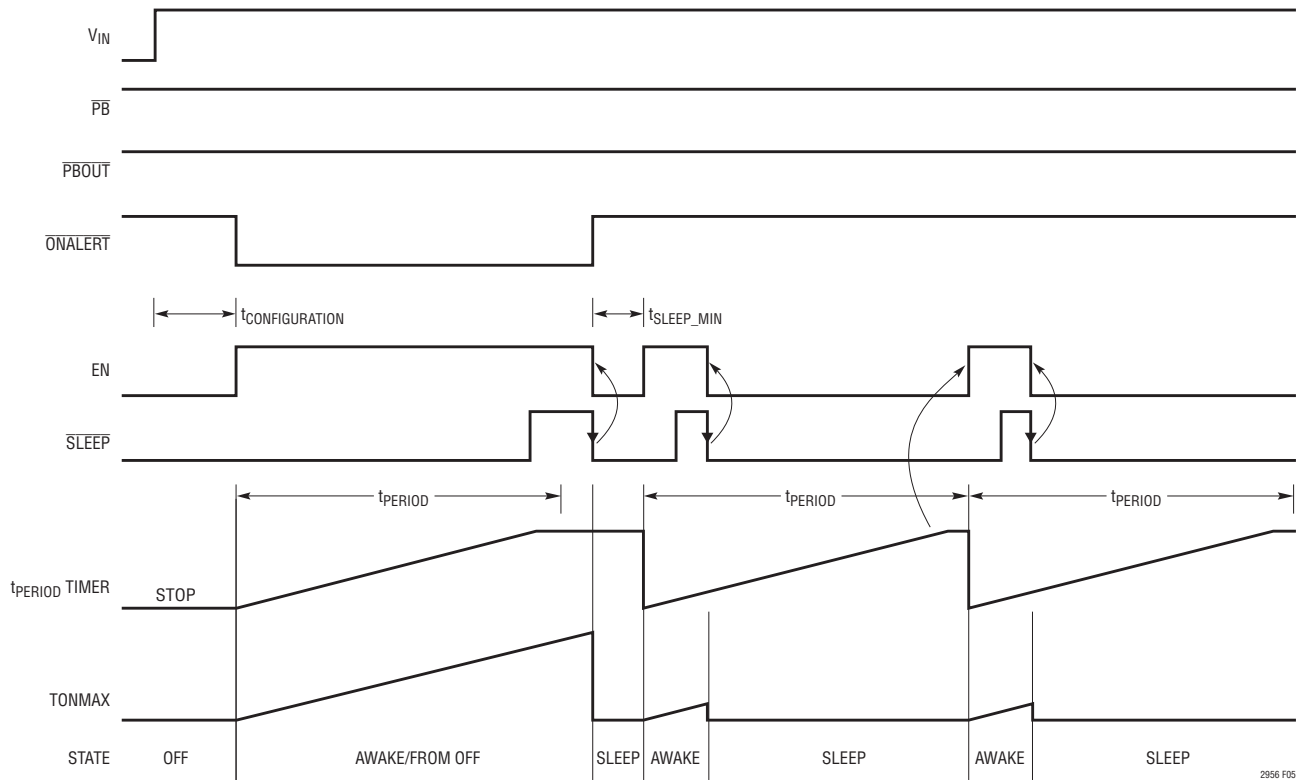

Figure 5. Wake-Up Timer Goes into RUN Mode After Power-Up ($V_{LONG} > V_{CC}/2$)

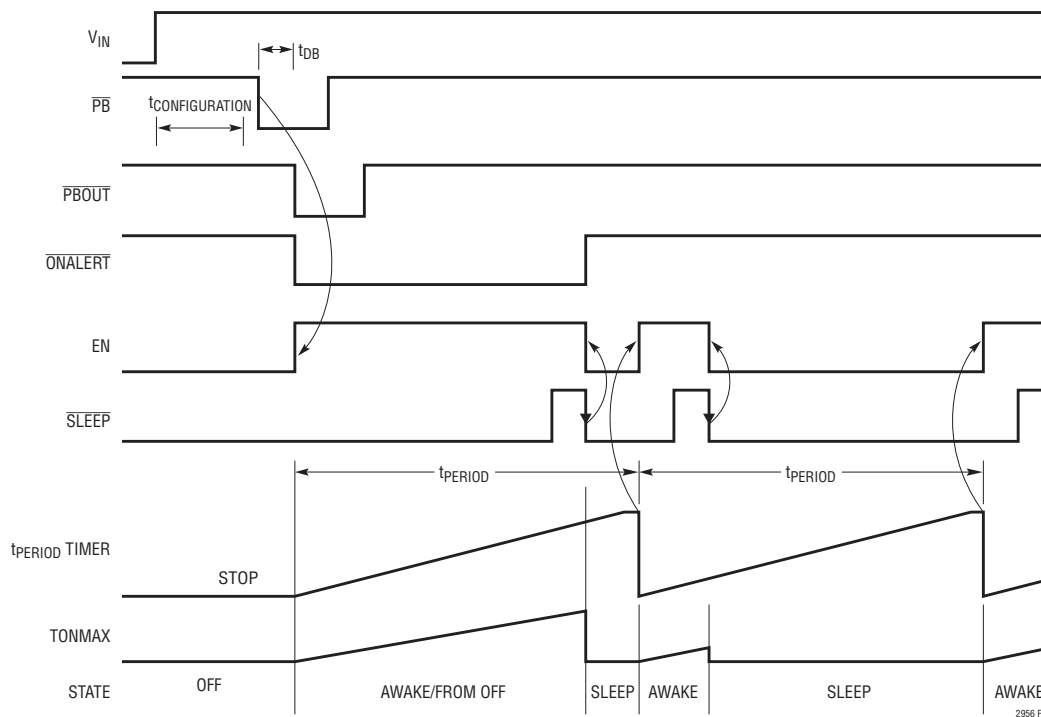

Figure 6. Using the \overline{PB} to Start the Wake-Up Timer

2956fa

OPERATION

The $\overline{\text{ONALERT}}$ open drain output is pulled low on the first Awake state after exiting SHUTDOWN mode or when first powered up with $V_{\text{LONG}} > V_{\text{CC}}/2$ selected. This output can be used to notify an active system to perform a power-up initialization routine.

Shutting Off with a Long $\overline{\text{PB}}$ Press

The LTC2956 can be put into the low power SHUTDOWN mode by holding the push button $\overline{\text{PB}}$ input low for a duration longer than t_{LONG} . The t_{LONG} can be adjusted with the resistive divider at the LONG pin. Figure 7 shows the timing during a long press. After the t_{LONG} timeout, the part enters the Shutting Off state, and the $\overline{\text{OFFALERT}}$ pin is pulled low. This state persists for t_{OFF} (typically 1s) thus

allowing an active system to perform power down tasks before the enable output is pulled low.

If the push button input is held low for a duration shorter than t_{LONG} , the LTC2956 pulls EN high but does not enter the Shutting off state. Once $\overline{\text{PB}}$ is released, the LTC2956 pulls the EN output low if the $\overline{\text{SLEEP}}$ pin has pulsed once or if t_{ONMAX} has timed out. This short press can be used to override the timer for early wake-up or it can be used with the $\overline{\text{PBOUT}}$ output to drive the software menu.

Pressing the pushbutton will always restart the t_{PERIOD} timer. This is useful for manual synchronization of the wake-up time with an external event. When the external event occurs, a short press will turn on the system and the next turn on will be t_{PERIOD} later.

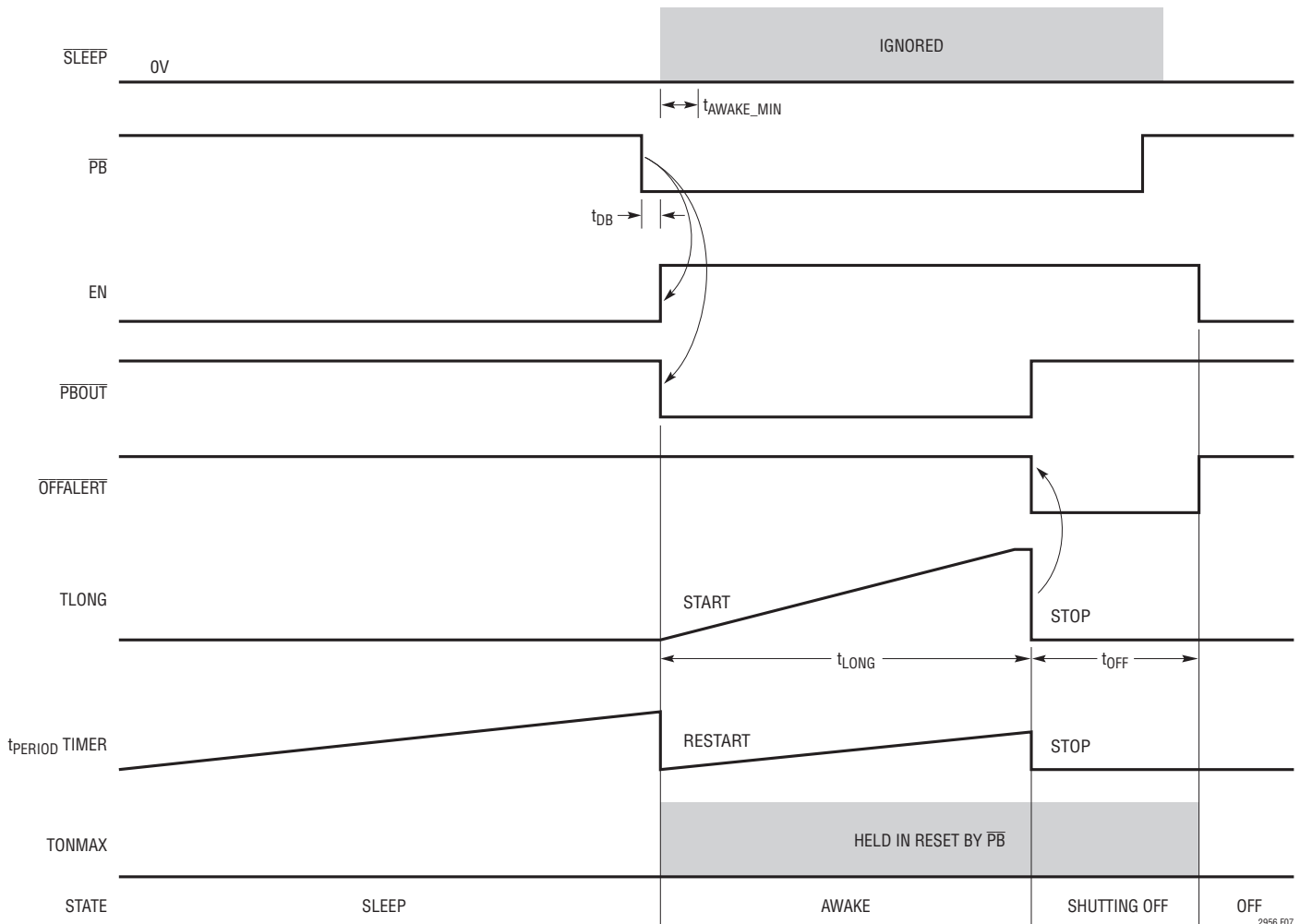

Figure 7. Holding $\overline{\text{PB}}$ Low to Enter SHUTDOWN Mode

2956fa

OPERATION

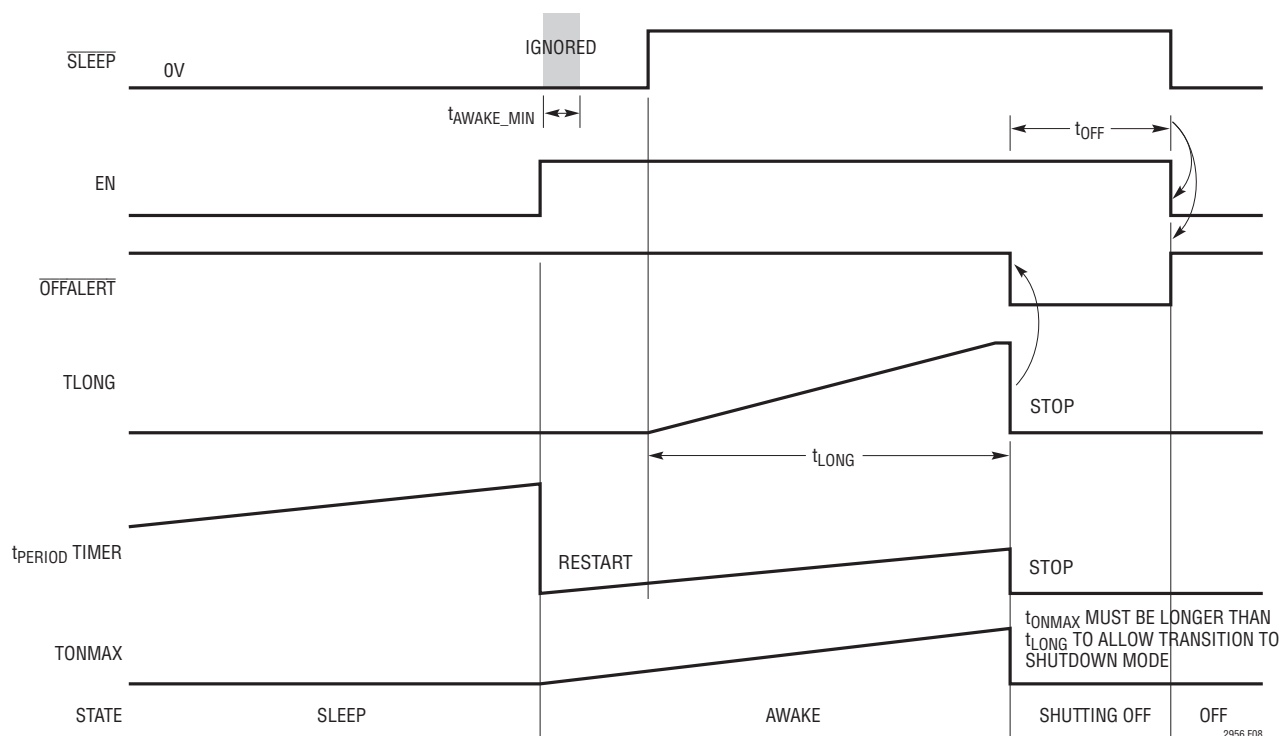

Figure 8. Holding $\overline{\text{SLEEP}}$ High to Enter SHUTDOWN Mode

Shutting Off with a Long $\overline{\text{SLEEP}}$ Pulse

In an active system, the LTC2956 can also be placed into the low power SHUTDOWN mode by holding $\overline{\text{SLEEP}}$ high for a duration greater than t_{LONG} (Figure 8). The $\overline{\text{OFFALERT}}$ pin is pulled low when t_{LONG} times out and remains low during the Shutting Off state. Unlike a long push button press event, however, the t_{ONMAX} timer remains enabled while $\overline{\text{SLEEP}}$ is pulled high. If t_{ONMAX} is adjusted to be less than t_{LONG} , a long $\overline{\text{SLEEP}}$ pulse can never trigger a shutdown.

If the $\overline{\text{SLEEP}}$ pulse width is shorter than t_{LONG} , the LTC2956 pulls the EN output high but does not enter the Shutting Off state. Once $\overline{\text{SLEEP}}$ goes low (or if t_{ONMAX} times out first), the EN output goes low and the device enters the Sleep state.

Pulling $\overline{\text{SLEEP}}$ High During the Sleep State

During the Sleep state, the system can prompt the LTC2956 to enter the Awake state by pulling $\overline{\text{SLEEP}}$ pin high even if the t_{PERIOD} time is not up. This is illustrated in Figure 9.

The LTC2956 automatically restarts the t_{PERIOD} timer when it enters the Awake state in response to the logic high on the $\overline{\text{SLEEP}}$ input.

Upon entering the Sleep state, the LTC2956 ignores all inputs for $t_{\text{SLEEP_MIN}}$. This allows time for the system's power supply to fully discharge before it is allowed to turn on again. If the system pulls $\overline{\text{SLEEP}}$ high during $t_{\text{SLEEP_MIN}}$, the LTC2956 will wait until $t_{\text{SLEEP_MIN}}$ expires before re-entering the Awake state.

Prolonging Awake Time

The LTC2956 restarts the t_{PERIOD} timer on every rising edge of EN. This allows the Awake time, t_{AWAKE} to vary from cycle to cycle while the turn-on period stay constant. However, if t_{AWAKE} extends toward or beyond t_{PERIOD} , the next Awake state may be delayed due to the minimum Sleep duration, $t_{\text{SLEEP_MIN}}$ (128ms typically). This $t_{\text{SLEEP_MIN}}$ ensures that the system supply has sufficient time to discharge. Refer to Figure 10, the second Awake time is longer, resulting in a longer t_{PERIOD} due to $t_{\text{SLEEP_MIN}}$.

OPERATION

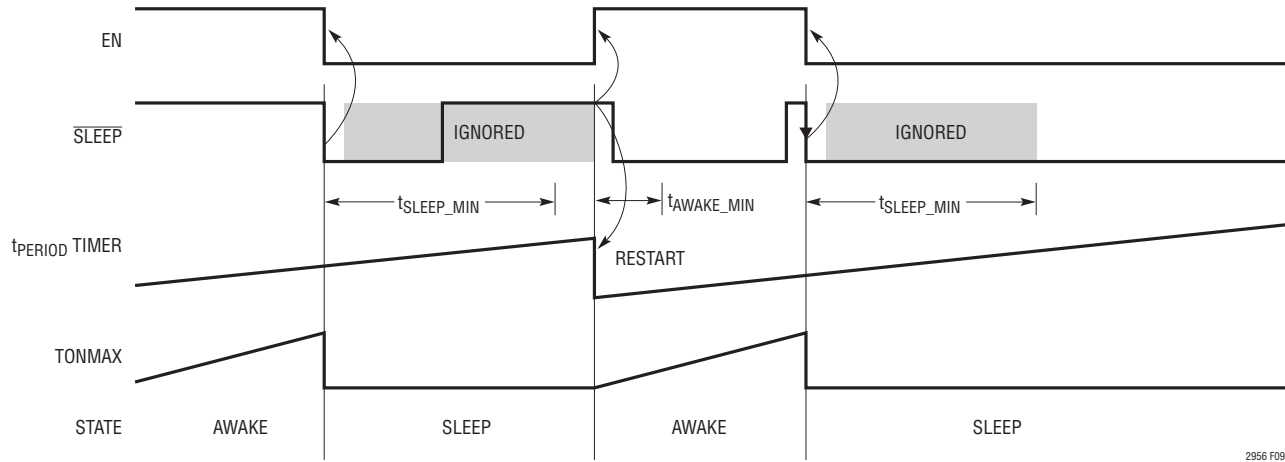

Figure 9. Pulling the $\overline{\text{SLEEP}}$ Input High to Enter Awake State

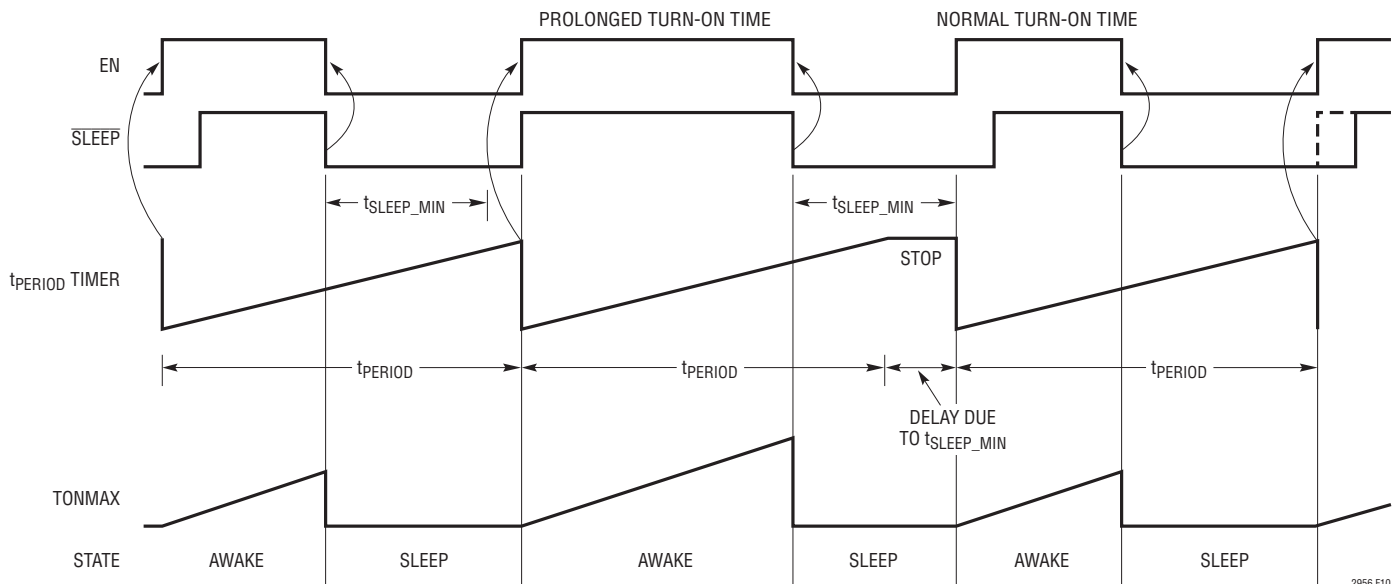

Figure 10. Prolonged Awake State

Push Button Debounce and $\overline{\text{PBOUT}}$

The $\overline{\text{PB}}$ input is debounced by an internal timer. This debounced signal is available at the $\overline{\text{PBOUT}}$ open drain output, and it can be used to interrupt the system for software purposes such as choosing an option from a menu. The initial $\overline{\text{PBOUT}}$ pulse in Awake state typically has a width of at least t_{PBOUT_FIRST} (128ms typical) which allows the

system sufficient time to respond just after powering up (see Figure 11). Subsequent $\overline{\text{PBOUT}}$ pulses have a width of at least t_{PD_DB} (32ms typical). Note that if the system's microcontroller toggles $\overline{\text{SLEEP}}$ during t_{PBOUT_FIRST}, the LTC2956 will enter the Sleep state and release $\overline{\text{PBOUT}}$ high without waiting for t_{PBOUT_FIRST} to complete.

OPERATION

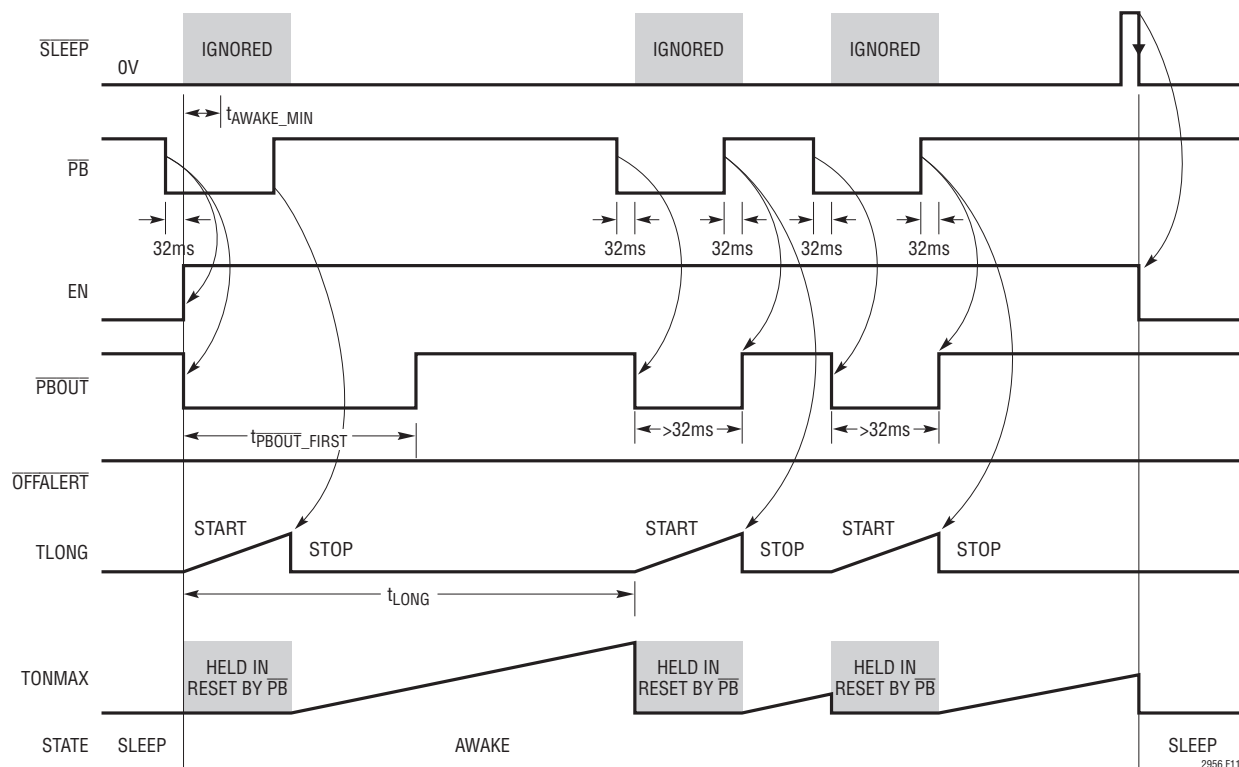

Figure 11. \overline{PBOUT} Echoing Debounced \overline{PB}

APPLICATIONS INFORMATION

Configuration

Configuring the LTC2956 wake-up timer is a 3-step process. The wake-up timer period is determined by the resistor to ground at the PERIOD pin and the resistive divider at the RANGE pin. Then the minimum time required for a long push button press that forces the wake-up timer into the SHUTDOWN mode is determined by another resistive divider at the LONG pin. Finally, the maximum awake time (t_{ONMAX}) is set with a capacitor to GND at the ONMAX pin. The LTC2956 biases and samples the voltages or current at these pins once every 66s while in RUN mode. The part also samples these pins following power-up and when in from Off state.

Step 1: Set t_{PERIOD} with resistors at the PERIOD and RANGE pins

The required resistance value at the PERIOD pin to set the wake-up timer period can be determined as follows:

$$R_{PERIOD} = 400 \cdot t_{PERIOD} / N_{RANGE} \text{ [k}\Omega\text{/s]}$$

N_{RANGE} is the internal clock divider and can be adjusted through the resistive divider at the RANGE pin as shown in Table 1. It is advisable to select an N_{RANGE} value that yields the largest allowable R_{PERIOD} value. The LTC2956's oscillator can run with values of R_{PERIOD} ranging from 32.4k Ω to 324k Ω .

For example, if a t_{PERIOD} of 3s is desired, $R_{PERIOD} = 75k$ and $N_{RANGE} = 16$ could be used, but $R_{PERIOD} = 300k$ and $N_{RANGE} = 4$ is a better choice.

APPLICATIONS INFORMATION

Table 1. RANGE Programming

RECOMMENDED t_{PERIOD}	NRANGE	R _{RANGE} * [k Ω]
0.25s to 0.8s	1	9.76
0.4s to 3.2s	4	17.4
1.6s to 12.8s	16	26.1
6.4s to 51.2s	64	35.7
25.6s to 3.4min	256	47.5
102s to 14min	1,024	61.9
6.8min to 55min	4,096	78.7
27min to 3.6hr	16,384	100
1.82hr to 15hr	65,536	127
7.28hr to 58hr	262,144	162
29hr to 233hr	1,048,576	210
233hr to 932hr	4,194,304	280

*R_{COM} = 100k Ω

Step 2: Set required pushbutton time for shutdown with the resistive divider at the LONG pin

The resistive divider at the LONG pin sets the t_{LONG} value and Power Up mode as shown in Table 2:

Table 2. t_{LONG} Programming

t_{LONG}	POWER UP MODE	R _{LONG} * [k Ω]
0.128s	SHUTDOWN	9.76
0.256s	SHUTDOWN	17.4
0.512s	SHUTDOWN	26.1
1.024s	SHUTDOWN	35.7
2.048s	SHUTDOWN	47.5
4.096s	SHUTDOWN	61.9
8.192s	SHUTDOWN	78.7
16.384s	SHUTDOWN	100
0.128s	RUN	127
0.256s	RUN	162
0.512s	RUN	210
1.024s	RUN	280
2.048s	RUN	383
4.096s	RUN	576
8.192s	RUN	1020
16.384s	RUN	Open

*R_{COM} = 100k Ω

Step 3: Set maximum Awake time using capacitor at ONMAX pin

The value of C_{ONMAX} can be determined by the equation:

$$C_{ONMAX} = t_{ONMAX} \cdot 75 \text{ [nF/s]}$$

For example, a t_{ONMAX} of 133ms requires a 10nF capacitor.

High Voltage PowerPath™ Switching

The high voltage \overline{EN} open drain output of the LTC2956-2 is designed to switch on/off an external power P-channel MOSFET. This allows a user to connect/disconnect a power supply (or battery) to its load by toggling the \overline{PB} pin. Figure 12 shows the LTC2956-2 switching a 24V battery application. R6 slows down the turning on of M1 so as to limit the inrush current when needed to charge up the capacitor at V_{OUT}. R5 is optional – it helps to speed up the turning off of M1 and also to keep M1 off when the input voltage rise time is fast.

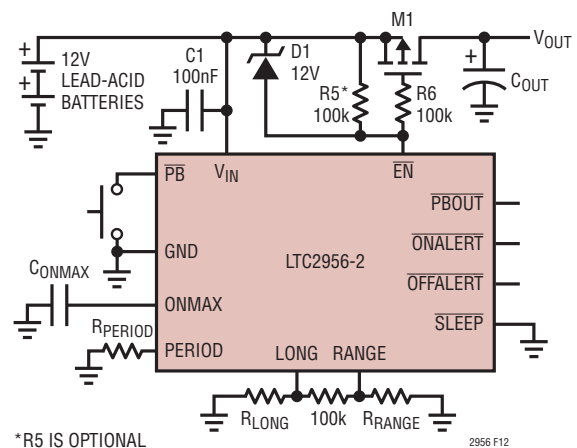

*R5 IS OPTIONAL

Figure 12. Switching 24V Battery Stack with External P-Channel MOSFET

\overline{PB} Pin in a Noisy Environment

The rugged \overline{PB} pin is designed to operate in noisy environments. Transients below ground and above V_{IN} will not damage the \overline{PB} pin. Additionally, the \overline{PB} pin can withstand ESD HBM strikes of up to $\pm 25kV$. However, if the pushbutton switch is located physically far from the

APPLICATIONS INFORMATION

LTC2956 $\overline{\text{PB}}$ pin, the parasitic capacitance and parasitic series inductance of the connecting cable or PCB trace can cause erratic behavior. The parasitic capacitance can couple external noise onto the $\overline{\text{PB}}$ input; placing a $0.1\mu\text{F}$ capacitor at the pin lessens the impact of this coupling. The parasitic series inductance may cause unpredictable ringing at the $\overline{\text{PB}}$ pin; placing a 5.1k resistor from the $\overline{\text{PB}}$ pin to the pushbutton switch reduces this ringing. Figure 13 shows an example of this RC network at the $\overline{\text{PB}}$ pin.

External Pull-Up Resistor on $\overline{\text{PB}}$ Pin

An internal 900k pull-up resistor on the $\overline{\text{PB}}$ pin makes an external pull-up resistor unnecessary. Leakage current on the $\overline{\text{PB}}$ board trace, however, will affect the open circuit voltage on the $\overline{\text{PB}}$ pin. If the leakage is too large ($>2\mu\text{A}$), the $\overline{\text{PB}}$ voltage may fall close to the threshold window. To mitigate the effect of board leakage, a 10k pull-up resistor to V_{IN} can be used (see Figure 14).

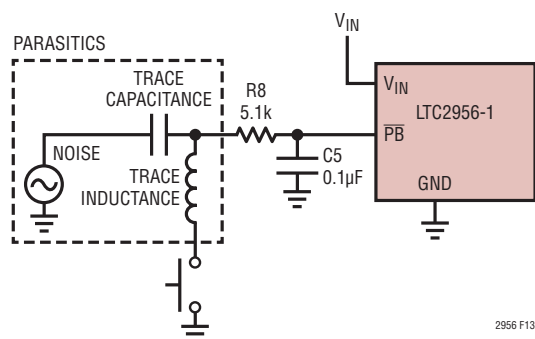

Figure 13. Noisy $\overline{\text{PB}}$ Trace

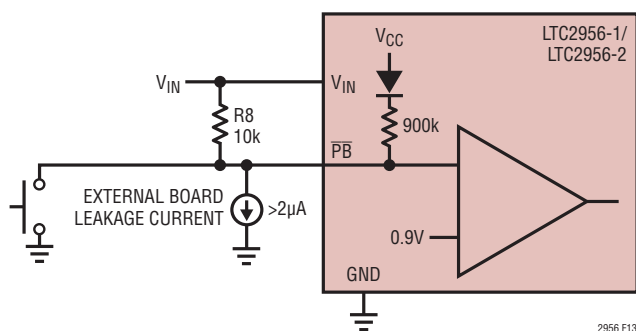

Figure 14. External Pull-Up Resistor on $\overline{\text{PB}}$ Pin for Board Leakage Greater than $2\mu\text{A}$

Enhancing V_{IN} Ruggedness and Reverse Battery Protection

Placing a 1k resistor and a 10nF capacitor at the V_{IN} pin can be used to enhance ruggedness in some applications (see Figure 15). The peak operating current of the LTC2956 is less than $10\mu\text{A}$, creating an insignificant 10mV drop across the 1k resistor. The 10nF bypass capacitor in combination with the 1k series resistor can protect against high voltage input transients that momentarily exceed the 40V absolute maximum voltage rating of the V_{IN} pin. These can occur during hot-plugging into a battery or AC adapter. This R-C filter can also protect against transients that may appear on the PCB ground during large ESD strikes at the $\overline{\text{PB}}$ pin.

A 1k resistor in series with the V_{IN} pin also allows the LTC2956 to withstand reverse-input voltages up to -40V . The LTC2956's V_{IN} pin is internally clamped to one diode voltage below ground and can tolerate up to 50mA of reverse current. In applications where a battery could be inserted backwards, this resistor will limit the reverse current to a safe level thus allowing internal clamping to protect the pin.

Figures 16a and 16b shows some additional simple reverse battery protection circuits that use a single MOSFET. Figure 16a illustrates a high-side PMOS in the power path while Figure 16b shows a low-side NMOS in the ground path. In each circuit, the MOSFET body diode is orientated in the direction of normal current flow. When the battery is installed incorrectly, the NMOS/PMOS gate is low/high, thus preventing the circuit from turning on. When the battery is properly installed, the NMOS/PMOS FET gate voltage is taken high/low, and its channel shorts out the diode.

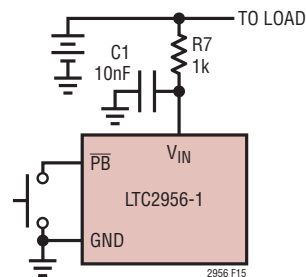

Figure 15. Enhancing V_{IN} Ruggedness

APPLICATIONS INFORMATION

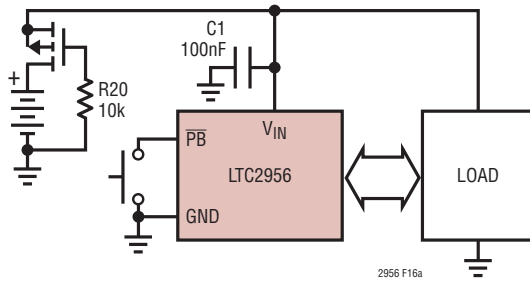

Figure 16a. PMOS Reverse Battery Protection

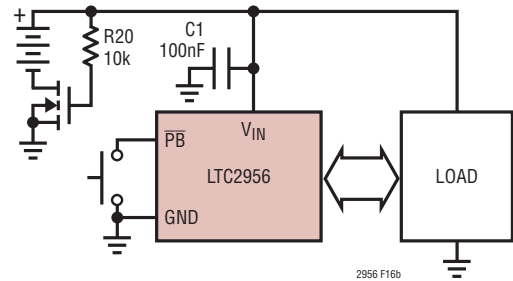

Figure 16b. NMOS Reverse Battery Protection

Interface with Switching Regulators

The LTC2956-1 EN pin can be connected directly to most switching regulator SHUTDOWN inputs. The EN pin high level output voltage ($V_{EN}(V_{OH})$) is typically 3.3V when $V_{IN} > 3.5V$, and $V_{EN}(V_{OH}) = V_{IN} - 0.1V$ if $V_{IN} < 3.0V$. With a minimum V_{IN} of 1.5V, $V_{EN}(V_{OH})$ is still higher than most SHUTDOWN thresholds. Figure 17 shows one such application. The LTC3528 regulator is a boost converter with a SHUTDOWN high threshold of 0.88V (maximum).

If a higher $V_{EN}(V_{OH})$ is required, an external pull-up resistor can be connected from the EN pin to any higher voltage ($< 36V$). The EN pin is designed to be able to sink at least 1mA of current during turn-off, so this external pull-up resistor value must be selected to source less than 1mA with EN at 0V. The LTC2956-1 EN pin can also be connected to switching regulators with a RUN/SS pin. RUN/SS typically has a dual function of a SHUTDOWN threshold and soft-start. Switching regulators optimized for

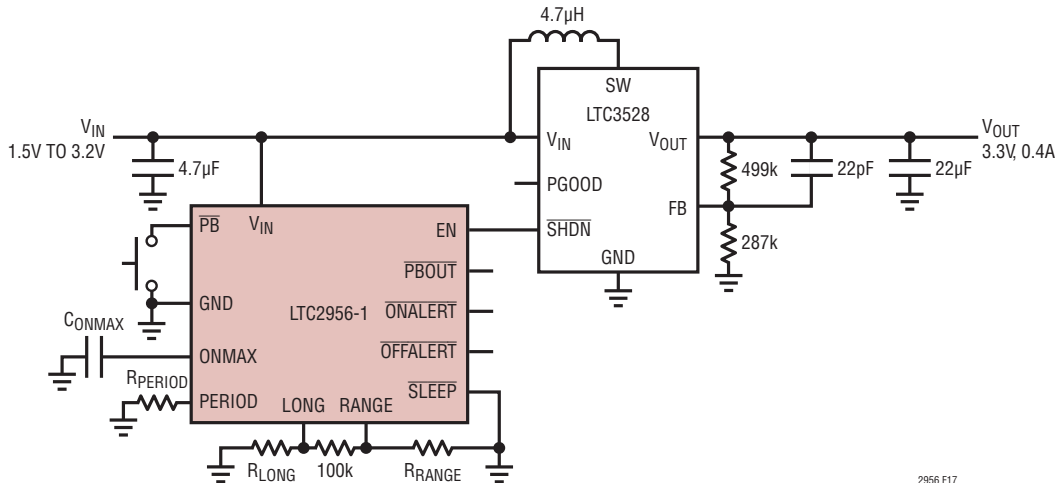
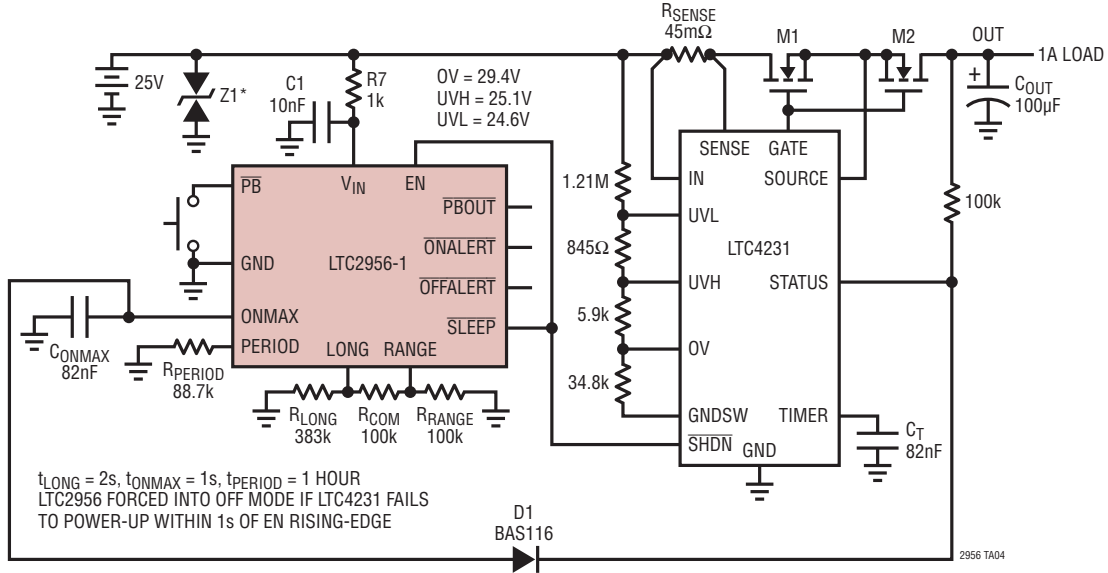

Figure 17. 2-Cell with 3.3V Output

2956 F17

TYPICAL APPLICATIONS

Micropower, Reverse Battery Protected Pushbutton Controller and Sleep Timer with Hot-Swap Controller



TYPICAL APPLICATIONS

Micropower Time-Lapse Photography Intervalometer

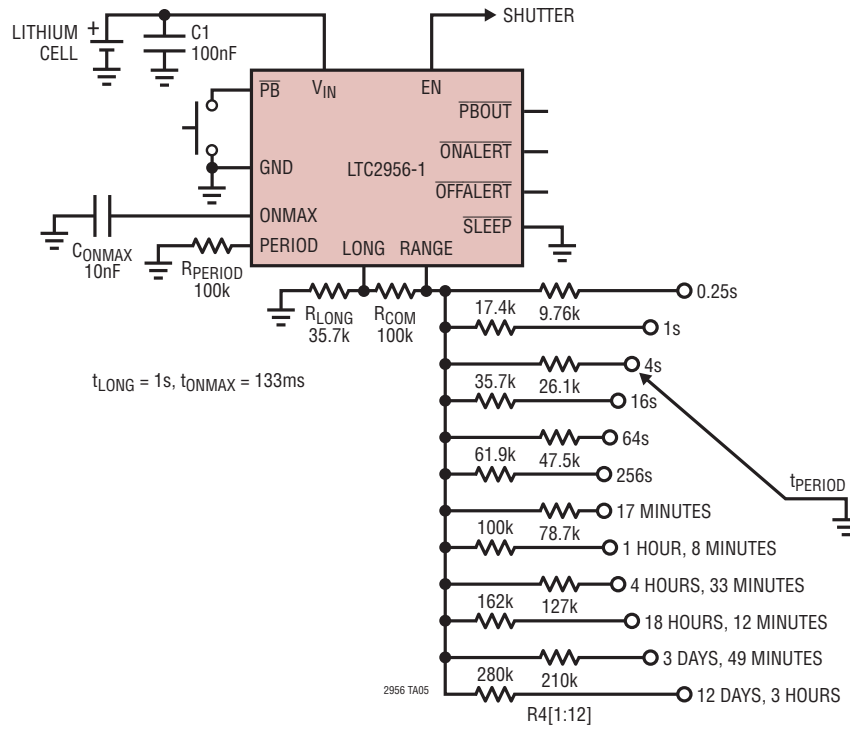

PACKAGE DESCRIPTION

Please refer to <http://www.linear.com/designtools/packaging/> for the most recent package drawings.

UD Package 12-Lead Plastic QFN (3mm × 3mm) (Reference LTC DWG # 05-08-1855 Rev 0)

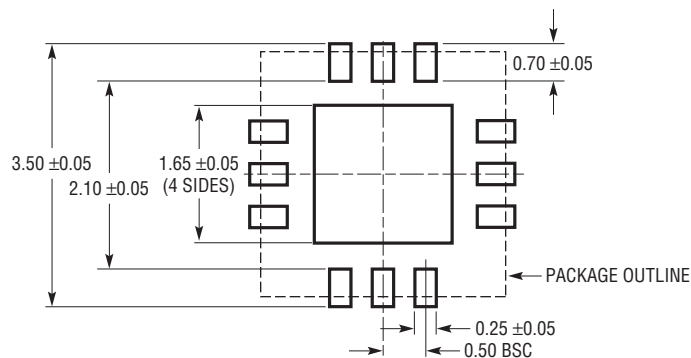

RECOMMENDED SOLDER PAD PITCH AND DIMENSIONS

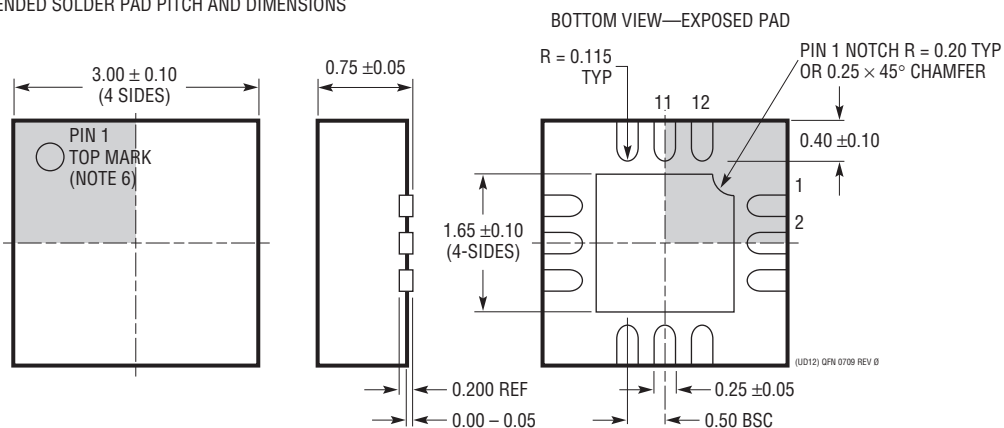

NOTE:

1. DRAWING CONFORMS TO JEDEC PACKAGE OUTLINE MO-220 VARIATION (WEED-1)
2. DRAWING NOT TO SCALE
3. ALL DIMENSIONS ARE IN MILLIMETERS
4. DIMENSIONS OF EXPOSED PAD ON BOTTOM OF PACKAGE DO NOT INCLUDE MOLD FLASH. MOLD FLASH, IF PRESENT, SHALL NOT EXCEED 0.15mm ON ANY SIDE
5. EXPOSED PAD SHALL BE SOLDER PLATED
6. SHADED AREA IS ONLY A REFERENCE FOR PIN 1 LOCATION ON THE TOP AND BOTTOM OF PACKAGE

PACKAGE DESCRIPTION

Please refer to <http://www.linear.com/designtools/packaging/> for the most recent package drawings.

MS Package 12-Lead Plastic MSOP

(Reference LTC DWG # 05-08-1668 Rev A)

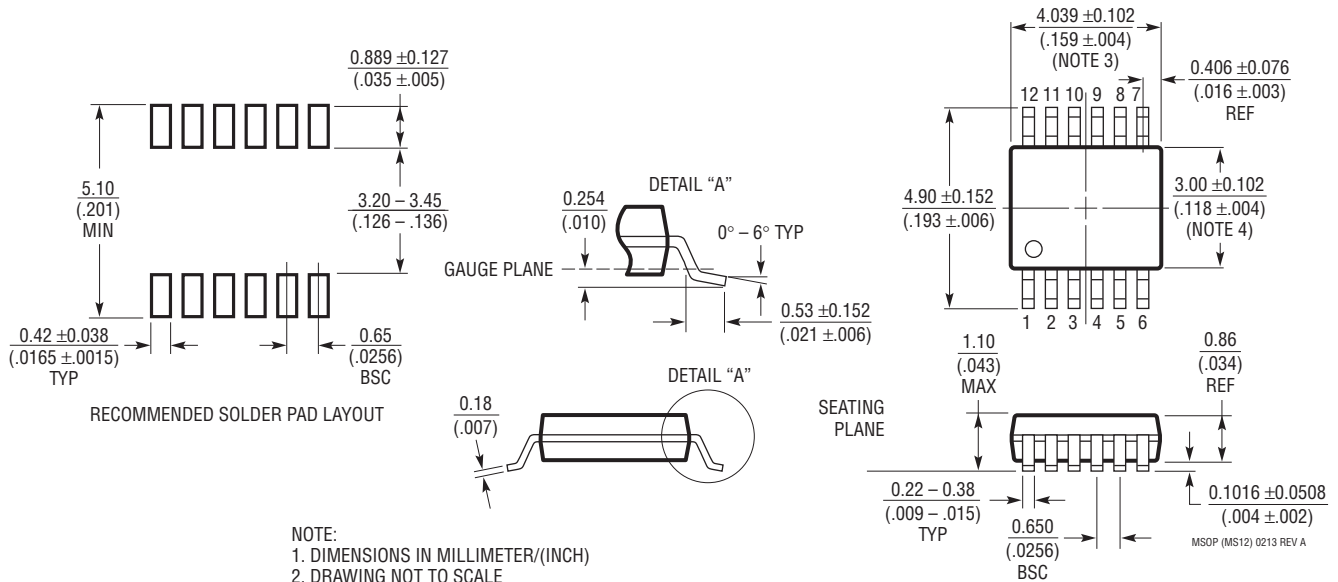

- NOTE:
1. DIMENSIONS IN MILLIMETER/(INCH)
 2. DRAWING NOT TO SCALE
 3. DIMENSION DOES NOT INCLUDE MOLD FLASH, PROTRUSIONS OR GATE BURRS.
MOLD FLASH, PROTRUSIONS OR GATE BURRS SHALL NOT EXCEED 0.152mm (.006") PER SIDE
 4. DIMENSION DOES NOT INCLUDE INTERLEAD FLASH OR PROTRUSIONS.
INTERLEAD FLASH OR PROTRUSIONS SHALL NOT EXCEED 0.152mm (.006") PER SIDE
 5. LEAD COPLANARITY (BOTTOM OF LEADS AFTER FORMING) SHALL BE 0.102mm (.004") MAX

REVISION HISTORY

REV	DATE	DESCRIPTION	PAGE NUMBER
A	07/15	Minor Edits	4, 6, 16, 22

TYPICAL APPLICATION

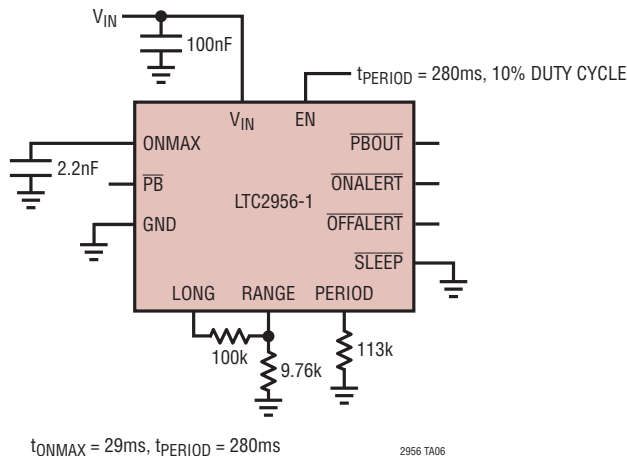

Low I_Q Timer with 10% Duty Cycle

RELATED PARTS

PART NUMBER	DESCRIPTION	COMMENTS
LTC2900	Adjustable Quad Supply Monitor	Adjustable $\overline{\text{RESET}}$, 10-Lead MSOP and 3mm × 3mm DFN Packages
LTC2904/LTC2905	Pin-Adjustable Dual Supply Monitors	Adjustable $\overline{\text{RESET}}$ and Tolerance, 8-Lead SOT-23 and 3mm × 2mm DFN Packages
LTC2909	Precision Triple/Dual Input UV, OV and Negative Voltage Monitor	6.5V Shunt Regulator for High Voltage Operation
LTC2910	Octal Positive/Negative Voltage Monitor	Eight Adjustable Inputs (0.5V)
LTC2914	Quad UV/OV Positive/Negative Voltage Monitor	Adjustable UV and OV Trip Values
LTC2950/LTC2951	Pushbutton On/Off Controllers	High Voltage, Low Power Pushbutton Controllers with Power-Down Fault Detect KILL Timer
LTC2952	Pushbutton PowerPath Controller with Supervisor	Automatic Low Loss Switchover Between DC Sources
LTC2953	Pushbutton Controller with Voltage Monitoring	Adjustable Supply Monitor with 200ms Reset
LTC2954	Pushbutton On/Off Controller with μP Interrupt	Adjustable Turn On/Off Timers
LTC2955	Pushbutton On/Off Controller with Automatic Turn-On	1.2 μA Supply Current
LTC4411	2.6A Low Loss Ideal Diode in ThinSOT™	No External MOSFET, Automatic Switching Between DC Sources
LTC4412HV	PowerPath Controller in ThinSOT	Efficient Diode-ORing, Automatic Switching Between DC Sources, 3V to 36V
LTC4055	USB Power Controller and Li-Ion Charger	Automatic Switchover, Charges 1-Cell Li-Ion Batteries
LTC4352	Ideal Diode Controller with Monitoring	Controls N-Channel MOSFET, 0V to 18V Operation

Looking for pricing, stock, or lifecycle information?

Click below to explore more details on WIN SOURCE:

-  [View LTC2956IMS-1#PBF on WIN SOURCE](#)
-  [Analog Devices Inc. Information](#)

Optimize Your Supply Chain with WIN SOURCE Solutions

-  Global Sourcing Solution
-  Obsolete Management
-  Cost Control Management
-  Shortage Management
-  Alternative Solution
-  Excess Inventory Management