



**THE DATASHEET OF
LTC2996HDD#TRPBF**



FEATURES

- Converts Remote or Internal Diode Temperature to Analog Voltage
- Adjustable Overtemperature and Undertemperature Thresholds
- Voltage Output Proportional to Temperature
- $\pm 1^\circ\text{C}$ Remote Temperature Accuracy
- $\pm 2^\circ\text{C}$ Internal Temperature Accuracy
- Built-In Series Resistance Cancellation
- Open Drain Alert Outputs
- 2.25V to 5.5V Supply Voltage
- 1.8V Reference Voltage Output
- 200 μA Quiescent Current
- 10-Lead 3mm \times 3mm DFN Package

APPLICATIONS

- Temperature Monitoring and Measurement
- System Thermal Control
- Network Servers
- Desktop and Notebook Computers
- Environmental Monitoring

DESCRIPTION

The LTC[®]2996 is a high accuracy temperature sensor with adjustable overtemperature and undertemperature thresholds and open drain alert outputs. It converts the temperature of an external diode sensor or its own die temperature to an analog output voltage while rejecting errors due to noise and series resistance. The measured temperature is compared against upper and lower limits set with resistive dividers. If a threshold is exceeded, the device communicates an alert by pulling low the correspondent open drain logic output.

The LTC2996 gives $\pm 1^\circ\text{C}$ accurate temperature results using commonly available NPN or PNP transistors or temperature diodes built into modern digital devices. A 1.8V reference output simplifies threshold programming and can be used as an ADC reference input.

The LTC2996 provides an accurate, low power solution for temperature monitoring in a compact 3mm \times 3mm DFN package.

LT, LT, LTC, LTM, Linear Technology and the Linear logo are registered trademarks of Linear Technology Corporation. All other trademarks are the property of their respective owners.

TYPICAL APPLICATION

Remote Temperature Monitor with Overtemperature and Undertemperature Thresholds

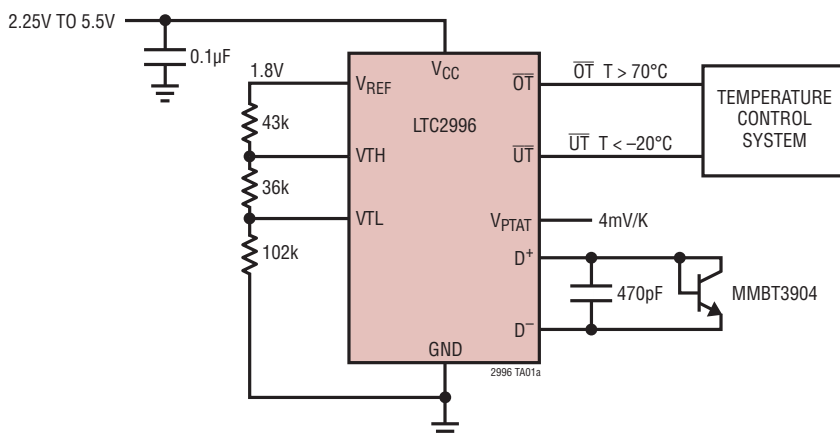

V_{PTAT} vs Remote Diode Temperature

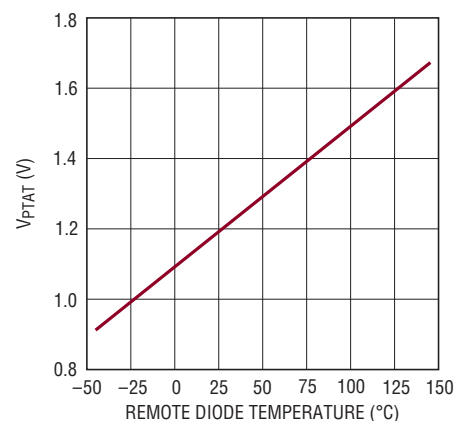

2996 TA01b

ABSOLUTE MAXIMUM RATINGS

(Notes 1, 2)

V_{CC}	-0.3V to 6V
D^+ , D^- , V_{PTAT} , V_{REF}	-0.3V to $V_{CC} + 0.3V$
\overline{OT} , \overline{UT} , V_{TH} , V_{TL}	-0.3V to 6V
Operating Ambient Temperature Range	
LTC2996C.....	0°C to 70°C
LTC2996I.....	-40°C to 85°C
LTC2996H.....	-40°C to 125°C
Storage Temperature Range	-65°C to 150°C

PIN CONFIGURATION

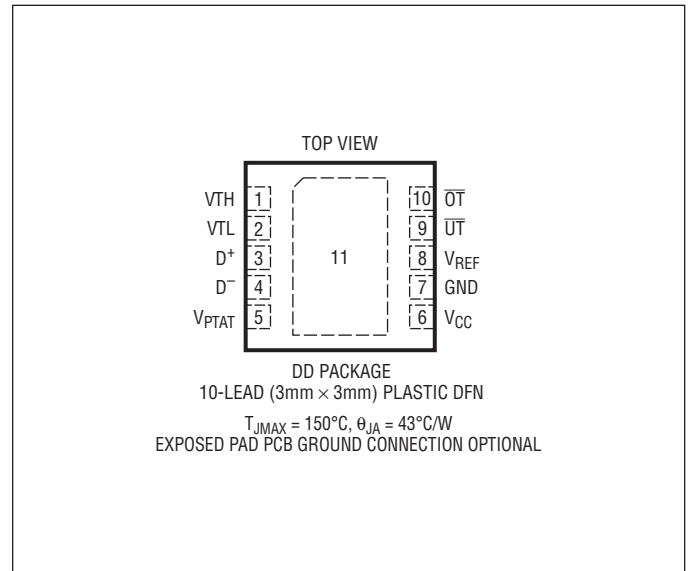

ORDER INFORMATION

LEAD FREE FINISH	TAPE AND REEL	PART MARKING*	PACKAGE DESCRIPTION	TEMPERATURE RANGE
LTC2996CDD#PBF	LTC2996CDD#TRPBF	LFQX	10-Lead (3mm × 3mm) Plastic QFN	0°C to 70°C
LTC2996IDD#PBF	LTC2996IDD#TRPBF	LFQX	10-Lead (3mm × 3mm) Plastic QFN	-40°C to 85°C
LTC2996HDD#PBF	LTC2996HDD#TRPBF	LFQX	10-Lead (3mm × 3mm) Plastic QFN	-40°C to 125°C

Consult LTC Marketing for parts specified with wider operating temperature ranges. *Temperature grades are identified by a label on the shipping container. Consult LTC Marketing for information on lead based finish parts.

For more information on lead free part marking, go to: <http://www.linear.com/leadfree/>

For more information on tape and reel specifications, go to: <http://www.linear.com/tapeandreel/>

ELECTRICAL CHARACTERISTICS

The ● denotes the specifications which apply over the full operating temperature range, otherwise specifications are at $T_A = 25^{\circ}C$, $V_{CC} = 3.3V$, unless otherwise noted.

SYMBOL	PARAMETER	CONDITIONS	MIN	TYP	MAX	UNITS
V_{CC}	Supply Voltage	●	2.25		5.5	V
UVLO	Supply Undervoltage Lockout Threshold	V_{CC} Falling ●	1.7	1.9	2.1	V
I_{CC}	Average Supply Current	●		200	300	μA

Temperature Measurement

V_{REF}	Reference Voltage	LTC2996	●	1.797	1.8	1.803	V
		LTC2996C	●	1.795	1.8	1.805	V
		LTC2996I, LTC2996H	●	1.790	1.8	1.808	V
	V_{REF} Load Regulation	$I_{LOAD} = \pm 200\mu A$, $V_{CC} = 3.3V$	●			± 1.5	mV
	Diode Select Threshold	(Note 3)	●	$V_{CC} - 600$	$V_{CC} - 300$	$V_{CC} - 100$	mV
	Remote Diode Sense Current			-8		-192	μA

ELECTRICAL CHARACTERISTICS

The ● denotes the specifications which apply over the full operating temperature range, otherwise specifications are at $T_A = 25^\circ\text{C}$, $V_{CC} = 3.3\text{V}$, unless otherwise noted.

SYMBOL	PARAMETER	CONDITIONS	MIN	TYP	MAX	UNITS
T_{CONV}	Temperature Update Interval			3.5	5	ms
K_T	V_{PTAT} Slope	Ideality Factor $\eta = 1.004$		4		mV/K
	V_{PTAT} Load Regulation	$I_{\text{LOAD}} = \pm 200\mu\text{A}$			± 1.5	mV
T_{INT}	Internal Temperature Accuracy	LTC2996C, LTC2996I LTC2996H		± 0.5 ± 0.5 ± 0.5	± 1 ± 2 ± 3	$^\circ\text{C}$ $^\circ\text{C}$ $^\circ\text{C}$
T_{RMT}	Remote Temperature Error, $\eta = 1.004$	0°C to 85°C (Notes 4, 5) -40°C to 0°C (Notes 4, 5) 85°C to 125°C (Notes 4, 5)		± 0.25 ± 0.25 ± 0.25	± 1 ± 1.5 ± 1.5	$^\circ\text{C}$ $^\circ\text{C}$ $^\circ\text{C}$
	Temperature Noise			0.15 0.01		$^\circ\text{C}_{\text{RMS}}$ $^\circ\text{C}_{\text{RMS}}/\sqrt{\text{Hz}}$
T_{VCC}	Temperature Error vs Supply				± 0.5	$^\circ\text{C}/\text{V}$
T_{RS}	Series Resistance Cancellation Error	$R_{\text{SERIES}} = 100\Omega$		± 0.25	± 1	$^\circ\text{C}$

Temperature Monitoring

T_{OFF}	V_{TH} , V_{TL} Offset		●	-3	-1	1	$^\circ\text{C}$
ΔT_{HYST}	$\overline{O_T}$, $\overline{U_T}$ Temperature Hysteresis		●	2	5	10	$^\circ\text{C}$
I_{IN}	V_{TH} , V_{TL} , Input Current		●			± 20	nA

Digital Outputs

V_{OH}	High Level Output Voltage, $\overline{O_T}$, $\overline{U_T}$	$I = -0.5\mu\text{A}$	●	$V_{\text{CC}} - 1.2$			V
V_{OL}	Low Level Output Voltage, $\overline{O_T}$, $\overline{U_T}$	$I = 3\text{mA}$	●		0.4		V

Note 1: Stresses beyond those listed under Absolute Maximum Ratings may cause permanent damage to the device. Exposure to any Absolute Maximum Rating condition for extended periods may affect device reliability and lifetime.

Note 2: All currents into pins are positive; all voltages are referenced to GND unless otherwise noted.

Note 3: If voltage on pin D^+ exceeds the diode select threshold the LTC2996 uses the internal diode sensor.

Note 4: Remote diode temperature, not LTC2996 temperature.

Note 5: Guaranteed by design and test correlation.

TYPICAL PERFORMANCE CHARACTERISTICS

$T_A = 25^\circ\text{C}$, $V_{CC} = 3.3\text{V}$ unless otherwise noted.

Temperature Error with LTC2996 at Same Temperature as Remote Diode

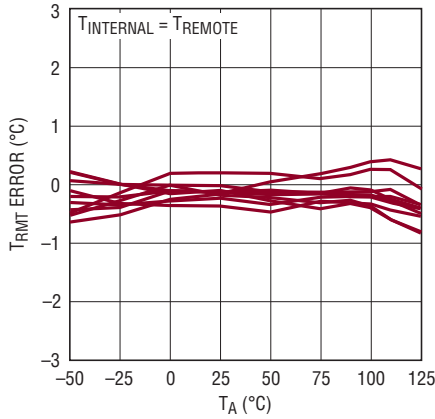

2996 G01

Remote Temperature Error vs Ambient Temperature

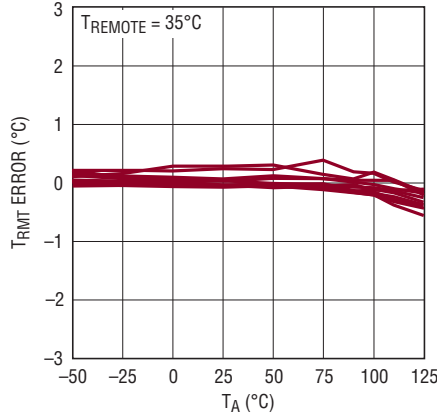

2996 G02

Internal Temperature Error vs Ambient Temperature

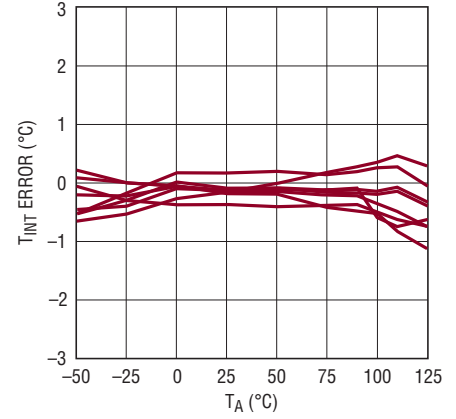

2996 G03

Temperature Error vs Supply Voltage

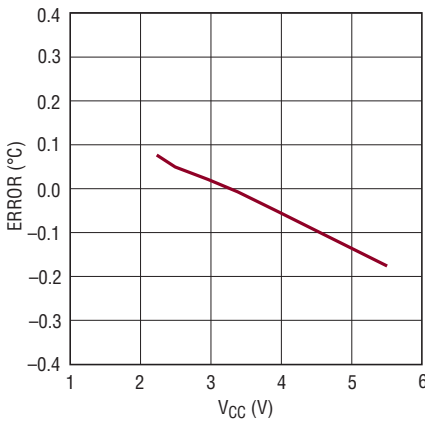

2996 G04

Remote Temperature Error vs Series Resistance

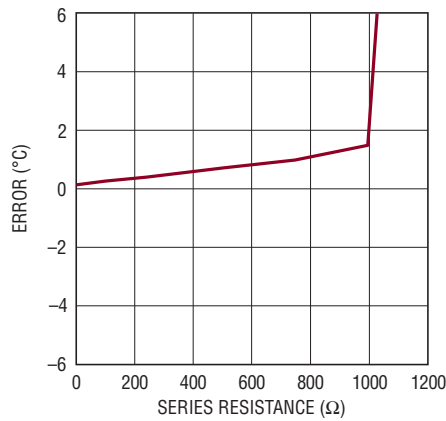

2996 G05

Remote Temperature Error vs C_DECOUPLE (Between D+ and D-)

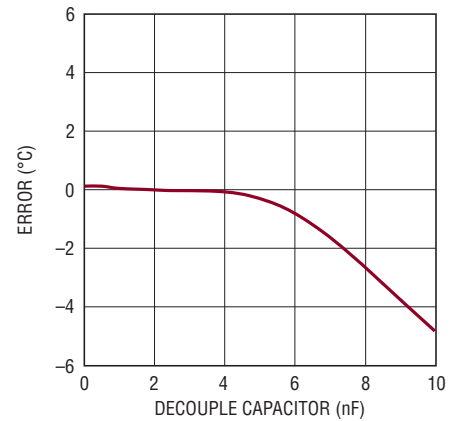

2996 G06

V_{PTAT} Noise vs Averaging Time

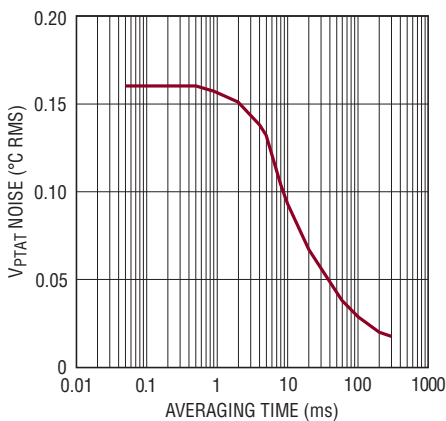

2996 G07

UVLO vs Temperature V_{CC} Rising, Falling

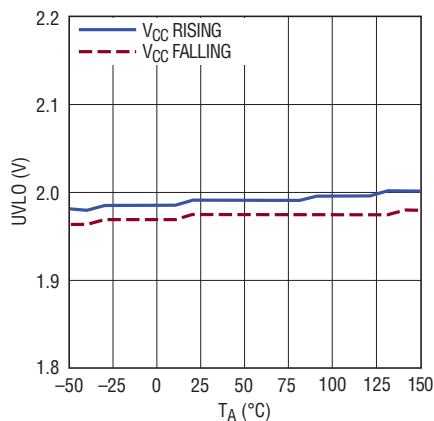

2996 G08

Buffered Reference Voltage vs Temperature

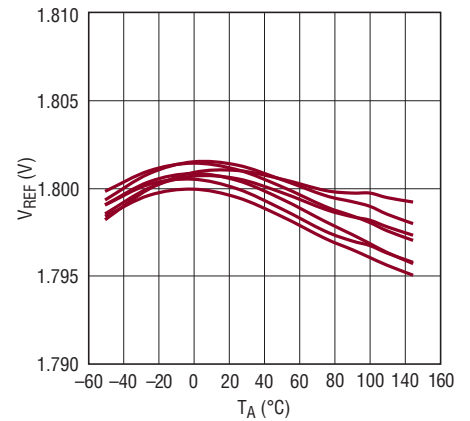

2996 G09

TYPICAL PERFORMANCE CHARACTERISTICS

$T_A = 25^\circ\text{C}$, $V_{CC} = 3.3\text{V}$ unless otherwise noted.

Load Regulation of V_{REF} Voltage vs Current

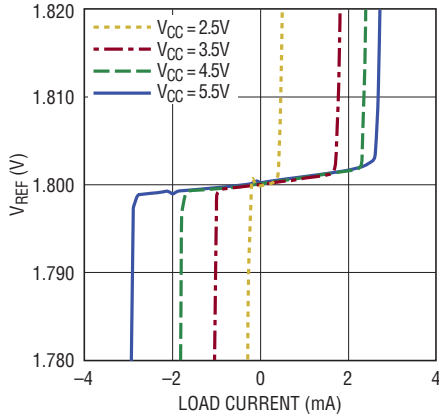

2996 G10

Load Regulation of V_{PTAT} Voltage vs Current

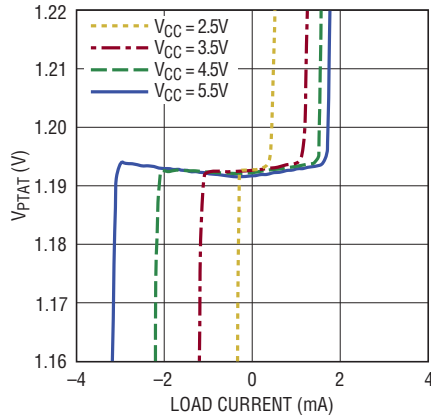

2996 G11

Single Wire Remote Temperature Error vs Ground Noise

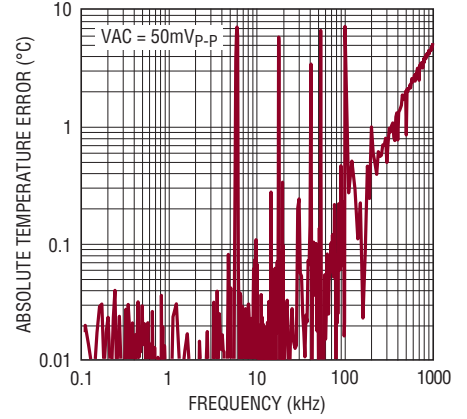

2996 G12

\overline{UT} , \overline{OT} , vs Output Sink Current

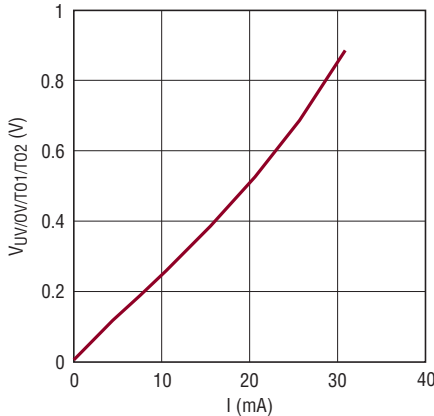

2996 G14

Supply Current vs Temperature

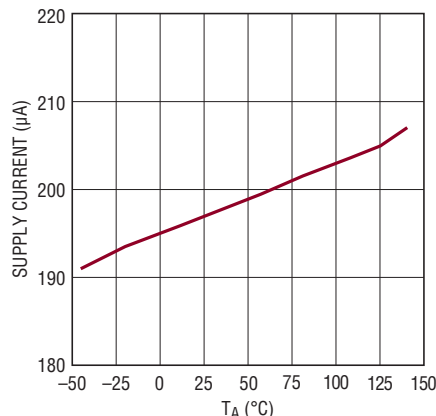

2996 G16

Remote Temperature Error vs Leakage Current at D^+ with Remote Diode at 25°C , T_{RMT}

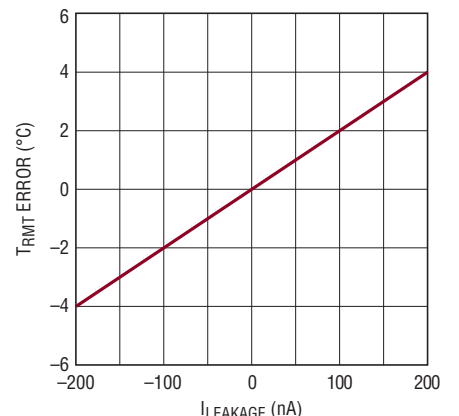

2996 G17

PIN FUNCTIONS

D⁺: Diode Sense Current Source. D⁺ sources the remote diode sensing current. Connect D⁺ to the anode of the remote sensor device. It is recommended to connect a 470pF bypass capacitor between D⁺ and D⁻. Larger capacitors may cause settling time errors (see Typical Performance Characteristics). If D⁺ is tied to V_{CC}, the LTC2996 measures the internal sensor temperature. Tie D⁺ to V_{CC} if unused.

D⁻: Diode Sense Current Sink. Connect D⁻ to the cathode of the remote sensor device. Tie D⁻ to GND for single wire remote temperature measurement (see Applications Information) or internal temperature sensing.

Exposed Pad: Exposed pad may be left open or soldered to GND for better thermal coupling.

GND: Device Ground

\overline{UT} : Undertemperature Logic Output. Open drain logic output that pulls to GND when V_{PTAT} is below the threshold voltage on pin VTL. When V_{PTAT} rises above the threshold voltage on pin VTL, an additional hysteresis of 20mV is required to release \overline{UT} high. \overline{UT} has a weak 400k Ω pull-up to V_{CC} and may be pulled above V_{CC} using an external pull-up. Leave \overline{UT} open if unused.

\overline{OT} : Overtemperature Logic Output. Open drain logic output that pulls to GND when V_{PTAT} is above the threshold voltage on pin VTH. When V_{PTAT} falls below the threshold voltage on pin VTH, an additional hysteresis of 20mV is required to release \overline{OT} high. \overline{OT} has a weak 400k Ω pull-up to V_{CC} and may be pulled above V_{CC} using an external pull-up. Leave \overline{OT} open if unused.

V_{PTAT}: Proportional to Absolute Temperature Voltage Output. The voltage on this pin is proportional to the sensor's absolute temperature. V_{PTAT} can drive up to $\pm 200\mu\text{A}$ of load current and up to 1000pF of capacitive load. For larger load capacitances insert 1k Ω between V_{PTAT} and the load to ensure stability. V_{PTAT} is pulled low when the supply voltage goes below the under voltage lockout threshold.

V_{REF}: Voltage Reference Output. V_{REF} provides a 1.8V reference voltage. V_{REF} can drive up to $\pm 200\mu\text{A}$ of load current and up to 1000pF of capacitive load. For larger load capacitances, insert 1k Ω between V_{REF} and the load to ensure stability. Leave V_{REF} open if unused.

VTL: Temperature Threshold Low. When V_{PTAT} is below the voltage on VTL, \overline{UT} is pulled low. Tie VTL to GND if unused.

VTH: Temperature Threshold High. When V_{PTAT} is above the voltage on VTH, \overline{OT} is pulled low. Tie VTH to V_{CC} if unused.

BLOCK DIAGRAM

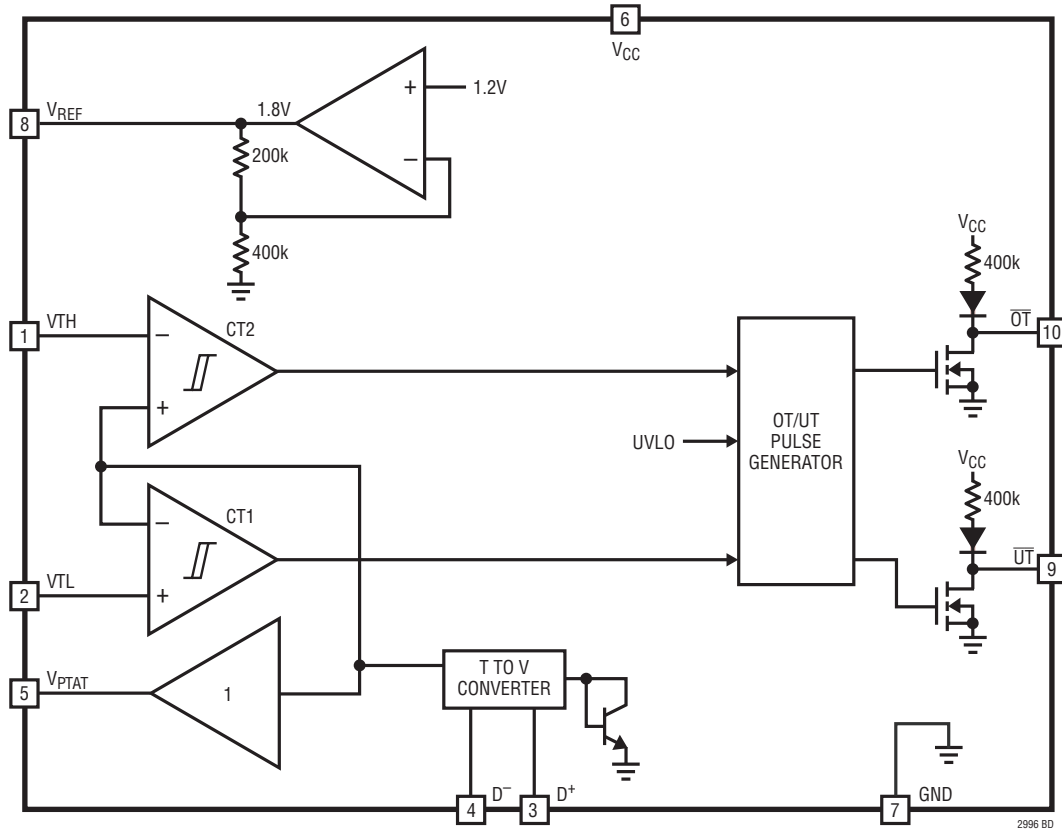

OPERATION

Overview

The LTC2996 provides a buffered voltage proportional to the absolute temperature of either an internal or a remote diode (V_{PTAT}) and compares this voltage to thresholds that can be set by external resistor dividers from the on-board reference (V_{REF}).

Remote temperature measurements usually use a diode connected transistor as a temperature sensor, allowing the remote sensor to be a discrete NPN (ex. MMBT3904) or an embedded device in a microprocessor or FPGA.

Diode Temperature Sensor

Temperature measurements are conducted by measuring the voltage of either an internal or an external diode with multiple test currents. The relationship between diode voltage V_D and diode current I_D can be solved for absolute Temperature in degrees Kelvin T:

$$T = \frac{q}{\eta \cdot k} \cdot \frac{V_D}{\ln\left(\frac{I_D}{I_S}\right)}$$

where I_S is a process dependent factor on the order of 10^{-13} A, η is the diode ideality factor, k is the Boltzmann constant and q is the electron charge. This equation shows a relationship between temperature and voltage dependent on the process depended variable I_S . Measuring the same

diode (with the same value I_S) at two different currents (I_{D1} and I_{D2}) yields an expression independent of I_S :

$$T = \frac{q}{\eta \cdot k} \cdot \frac{V_{D2} - V_{D1}}{\ln\left(\frac{I_{D2}}{I_{D1}}\right)}$$

Series Resistance Cancellation

Resistance in series with the remote diode causes a positive temperature error by increasing the measured voltage at each test current. The composite voltage equals:

$$V_D + V_{ERROR} = \eta \frac{kT}{q} \cdot \ln\left(\frac{I_D}{I_S}\right) + R_S \cdot I_D$$

The LTC2996 removes this error term from the sensor signal by subtracting a cancellation voltage V_{CANCEL} . A resistance extraction circuit uses one additional current measurement to determine the series resistance in the measurement path. Once the correct value of the resistor is determined, V_{CANCEL} equals V_{ERROR} . Now the temperature to voltage converter input signal is free from errors due to series resistance.

LTC2996 cancels series resistances up to several hundred ohms (see Typical Performance Characteristics curves). Higher series resistances cause the cancellation voltage to saturate.

APPLICATIONS INFORMATION

Temperature Measurements

Before each conversion, a voltage comparator connected to D⁺ automatically sets the LTC2996 into external or internal mode. Tying D⁺ to V_{CC} enables internal mode, where V_{PTAT} represents the die temperature. For V_{D⁺} more than 300mV below V_{CC} (typical), the LTC2996 assumes that an external sensor is connected.

The LTC2996 continuously measures the sensor diode at different test currents and generates a voltage proportional to the absolute temperature of the sensor at the V_{PTAT} pin. The voltage at V_{PTAT} is updated every 3.5ms.

The gain of V_{PTAT} is calibrated to 4mV/K for the measurement of the internal diode as well as for remote diodes with an ideality factor of 1.004.

$$T_{\text{KELVIN}} = \frac{V_{\text{PTAT}}}{4\text{mV/K}} \quad (\eta = 1.004)$$

If an external sensor with an ideality factor different from 1.004 is used, the gain of V_{PTAT} will be scaled by the ratio of the actual ideality factor (η_{ACT}) to 1.004. In these cases the temperature of the external sensor can be calculated from V_{PTAT} by:

$$T_{\text{KELVIN}} = \frac{V_{\text{PTAT}}}{4\text{mV/K}} \cdot \frac{1.004}{\eta_{\text{ACT}}}$$

Temperature in degrees Celsius can be deduced from degrees Kelvin by:

$$T_{\text{CELSIUS}} = T_{\text{KELVIN}} - 273.15$$

Choosing an External Sensor

The LTC2996 is factory calibrated for an ideality factor of 1.004, which is typical of the popular MMBT3904 NPN transistor. Semiconductor purity and wafer level processing intrinsically limit device-to-device variation, making these devices interchangeable between manufacturers with a temperature error of typically less than 0.5°C. Some recommended sources are listed in Table 2:

Table 2. Recommended Transistors for Use as Temperature Sensors

MANUFACTURER	PART NUMBER	PACKAGE
Fairchild Semiconductor	MMBT3904	SOT-23
Central Semiconductor	CMBT3904	SOT-23
Diodes Inc.	MMBT3904	SOT-23
On Semiconductor	MMBT3904LT1	SOT-23
NXP	MMBT3904	SOT-23
Infineon	MMBT3904	SOT-23
Rohm	UMT3904	SC-70

Discrete two terminal diodes are not recommended as remote sensing devices as their ideality factor is typically much higher than 1.004. Also, MOS transistors are not suitable as they don't exhibit the required current to temperature relationship. Furthermore, gold doped transistors (low beta), high frequency and high voltage transistors should be avoided as remote sensing devices.

Connecting an External Sensor

The anode of the external sensor must be connected to pin D⁺. The cathode should be connected to D⁻ for best external noise immunity.

The change in sensor voltage per °C is hundreds of microvolts, so electrical noise must be kept to a minimum. Bypass D⁺ and D⁻ with a 470pF capacitor close to the LTC2996 to suppress external noise. Recommended shielding and PCB trace considerations for best noise immunity are illustrated in Figure 1.

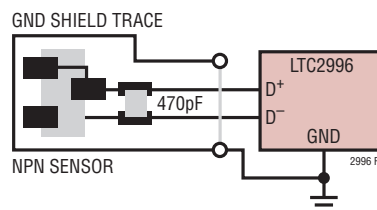

Figure 1. Recommended PCB Layout

Leakage currents at D⁺ affect the precision of the remote temperature measurements. 100nA leakage current leads to an additional error of 2°C (see Typical Performance Characteristics).

APPLICATIONS INFORMATION

Note that bypass capacitors greater than 1nF will cause settling time errors of the different measurement currents and therefore introduce an error in the temperature measurement (see Typical Performance Characteristics).

The LTC2996 compensates series resistance in the measurement path and thereby allows accurate remote temperature measurements even with several meters of distance between the sensor and the device. The cable length between the sensor and the LTC2996 is only limited by the mutual capacitance introduced between D⁺ and D⁻ which degrades measurement accuracy (see Typical Performance Characteristics).

For example, a CAT6 cable with 50pF/m should be kept shorter than ~20m to keep the capacitance less than 1nF.

To save wiring, the cathode of the remote sensor can also be connected to remote GND and D⁻ to local GND as shown below.

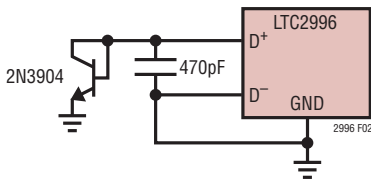

Figure 2. Single Wire Remote Temperature Sensing

The temperature measurement of LTC2996 relies only on differences between the diode voltage at multiple test circuits. Therefore DC offsets smaller than 300mV between remote and local GND do not impact the precision of the temperature measurement. The cathode of the sensor can accommodate modest ground shifts across a system which is beneficial in applications where a good thermal connectivity of the sensor to a device whose temperature is to be monitored (shunt resistor, coil, etc.) is required. Care must be taken if the potential difference between the cathode and D⁻ does not only contain DC but also AC components. Noise around odd multiples of 6kHz ($\pm 20\%$) is amplified by the measurement algorithm and converted to a DC offset in the temperature measurement (see Typical Performance Characteristics).

The LTC2996 can withstand up to $\pm 4\text{kV}$ of electrostatic discharge (ESD, human body model). ESD beyond this voltage can damage or degrade the device including lowering the remote sensor measurement accuracy due to increased leakage currents on D⁺ or D⁻.

To protect the sensing inputs against larger ESD strikes, external protection can be added using TVS diodes to ground (Figure 3). Care must be taken to choose diodes with low capacitance and low leakage currents in order not to degrade the external sensor measurement accuracy (see Typical Performance Characteristics curves).

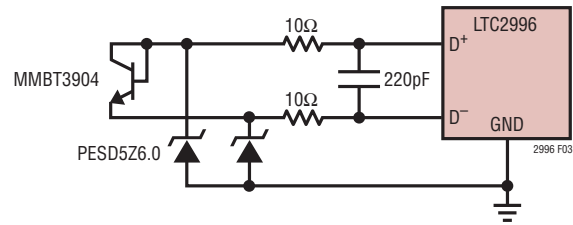

Figure 3. Increasing ESD Robustness with TVS Diodes

To make the connection of the cable to the IC polarity insensitive during installation, two sensor transistors with opposite polarity at the end of a two wire cable can be used as shown on Figure 4.

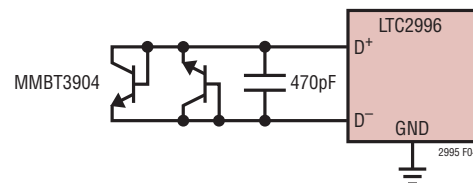

Figure 4. Polarity Insensitive Remote Diode Sensor

Again, care must be taken that the leakage current of the second transistor does not degrade the measurement accuracy.

APPLICATIONS INFORMATION

Output Noise Filtering

The V_{PTAT} output typically exhibits 0.6mV RMS (0.25°C RMS) noise. For applications which require lower noise, digital or analog averaging can be applied to the output. Choose the averaging time according to:

$$t_{AVG} = \left(\frac{0.01 [^{\circ}\text{C}\sqrt{\text{Hz}}]}{T_{NOISE}} \right)^2$$

where t_{AVG} is the averaging time and T_{NOISE} the desired temperature noise in °C RMS. For example, if the desired noise performance is 0.01°C RMS, set the averaging time to one second. See Typical Performance Characteristics.

Temperature Monitoring

The LTC2996 continuously compares the voltage at V_{PTAT} to the voltages at the pins V_{TH} and V_{TL} to detect either an overtemperature (OT) or undertemperature (UT) condition. The V_{TH} comparator output drives the open-drain logic output pin \overline{OT} and the V_{TL} comparator output drives the open-drain logic output pin \overline{UT} . The voltage at V_{PTAT} must exceed a threshold for five consecutive temperature update intervals (3.5ms each) before the respective output pin is pulled low. Once the V_{PTAT} voltage crosses the threshold with an additional 20mV of hysteresis, the respective output pin is released after a single update interval.

Temperature Monitor Design Example

The LTC2996 can be configured to give an alert if the temperature of the internal sensor falls below 0°C or rises above 90°C. Tie the D^+ pin to V_{CC} to select the internal sensor. The voltages at V_{TL} and V_{TH} are set to:

$$V_{TL} = (0\text{K} + 273.15\text{K}) \cdot 4 \frac{\text{mV}}{\text{K}} = 1.093\text{V}$$

$$V_{TH} = (90\text{K} + 273.15\text{K}) \cdot 4 \frac{\text{mV}}{\text{K}} = 1.453\text{V}$$

When V_{PTAT} falls below 1.093V, \overline{UT} is pulled low. Once the temperature rises again and V_{PTAT} reaches 1.093V plus a hysteresis of 20mV, \overline{UT} is released high again. Accordingly, \overline{OT} is pulled low if temperature increases to 90°C as V_{PTAT} reaches 1.453V and is released high if V_{PTAT} drops again below 1.433V.

Temperature Thresholds

The threshold voltages at V_{TL} and V_{TH} can be set with the 1.8V reference voltage (V_{REF}) and a resistive divider as shown in Figure 5.

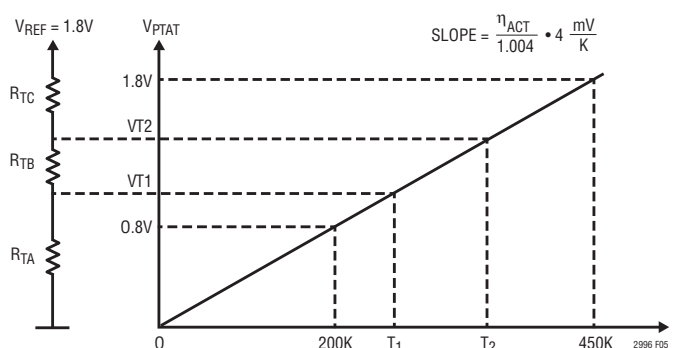

Figure 5. Temperature Thresholds

The following design procedure can be used to size the resistive divider.

1. Calculate Threshold Voltages:

$$V_{TL} = T1 \cdot 4 \frac{\text{mV}}{\text{K}} \cdot \frac{\eta_{ACT}}{1.004}$$

$$V_{TH} = T2 \cdot 4 \frac{\text{mV}}{\text{K}} \cdot \frac{\eta_{ACT}}{1.004}$$

APPLICATIONS INFORMATION

where η_{ACT} denotes the actual ideality factor if an external sensor is used and T1 and T2 are the desired threshold temperatures in degrees Kelvin.

- Choose R_{TA} to obtain the desired V_{TL} threshold for a desired current through the resistive divider (I_{REF}):

$$R_{TA} = \frac{V_{TL}}{I_{REF}}$$

- Choose R_{TB} to obtain the desired V_{TH} threshold:

$$R_{TB} = \frac{V_{TH} - V_{TL}}{I_{REF}}$$

- Finally R_{TC} is determined by:

$$R_{TC} = \frac{1.8V - V_{TH}}{I_{REF}}$$

In the Temperature Monitor example discussed earlier with thresholds at $V_{TL} = 0^{\circ}C$ and $V_{TH} = 90^{\circ}C$ and a desired reference current of $10\mu A$, the required values for R_{TA} , R_{TB} and R_{TC} can be calculated as :

$$R_{TA} = \frac{1.093V}{10\mu A} = 109.3K$$

$$R_{TB} = \frac{1.453V - 1.093V}{10\mu A} = 36K$$

$$R_{TC} = \frac{1.8V - 1.453V}{10\mu A} = 34.7K$$

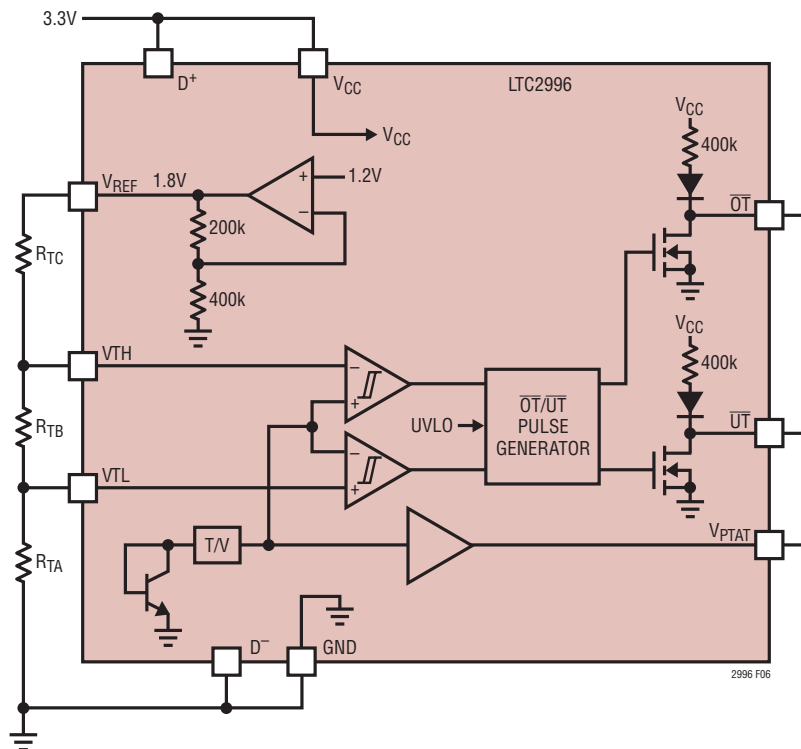
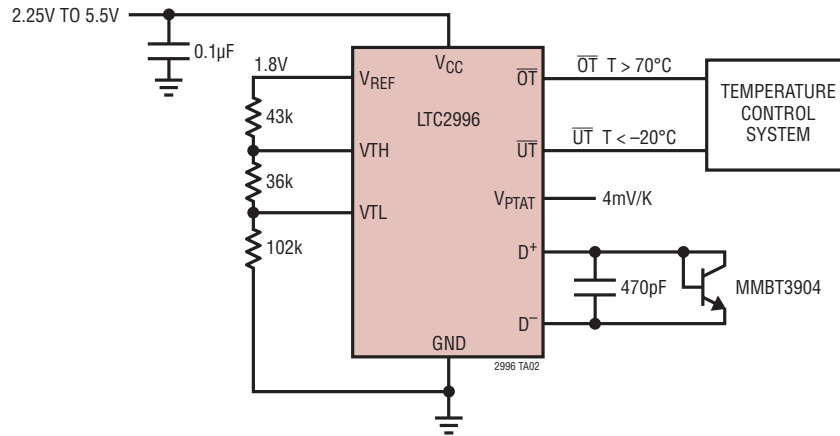

Figure 6. Monitoring Internal Temperature

APPLICATIONS INFORMATION

Remote Temperature Monitor with Overtemperature and Undertemperature Thresholds



ASIC/FPGA/Processor Temperature Monitor

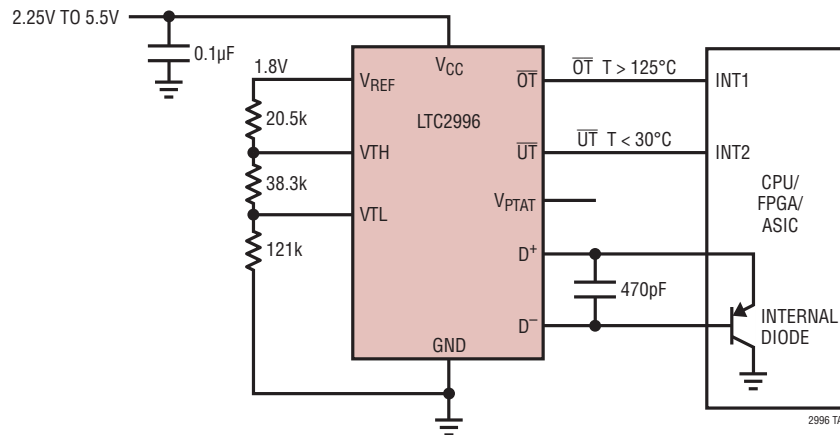

Analog Heater Controller

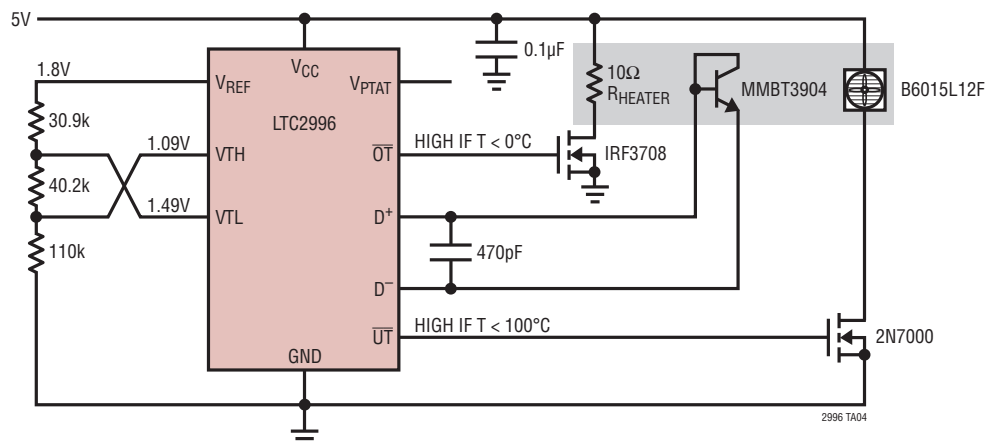

TYPICAL APPLICATIONS

Battery Stack Temperature Supervisor

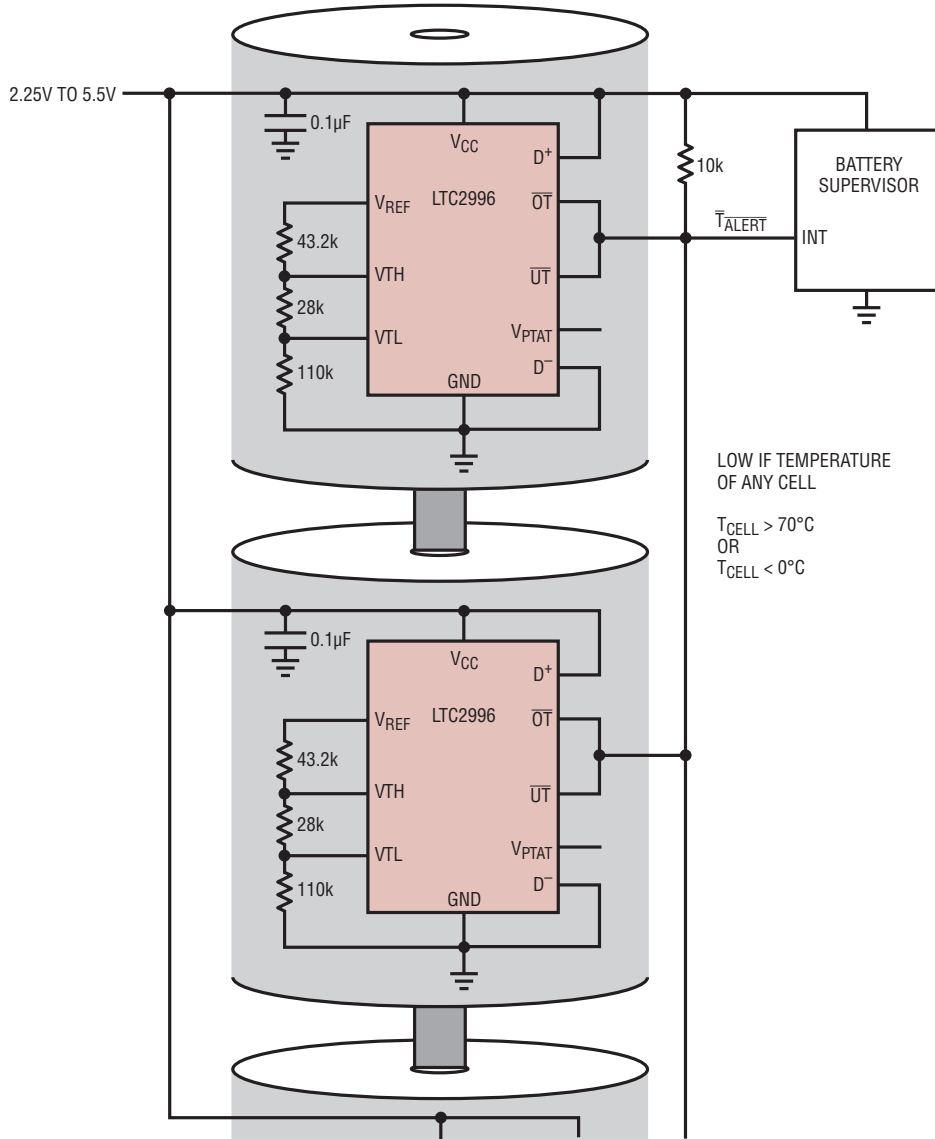

2996 TA05

TYPICAL APPLICATION

Celsius Thermometer and 20°C to 25°C Thermostat

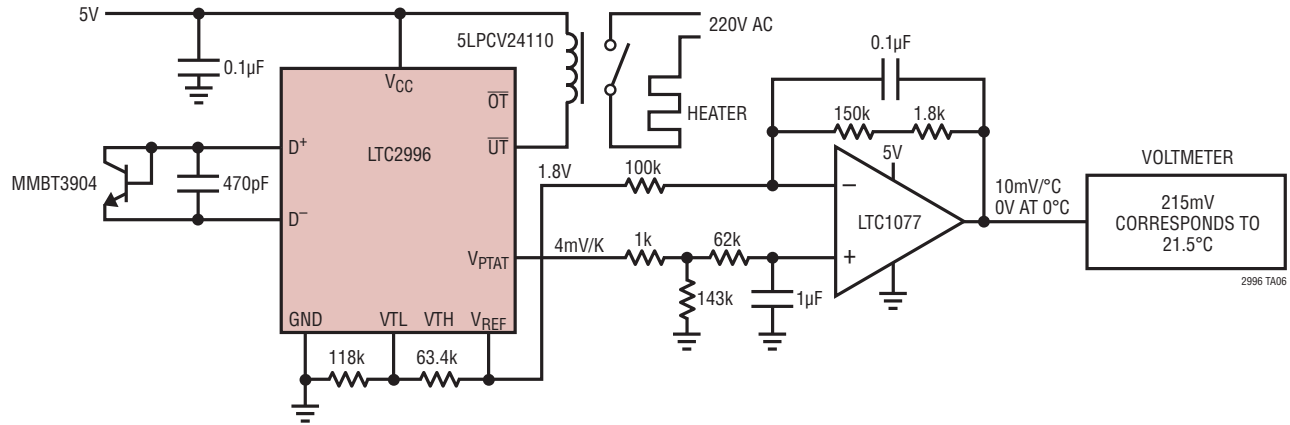

RELATED PARTS

PART NUMBER	DESCRIPTION	COMMENTS
LTC2990	Quad I ² C Voltage, Current and Temperature Monitor	Measures Voltage, Current, Internal Temperature and/or Two Remote Diode Temperatures, ±0.5°C (Typ) Accuracy, 0.06°C Resolution, I ² C Interface
LTC2991	Octal I ² C Voltage, Current and Temperature Monitor	Measures Voltage, Current, Internal Temperature and/or Four Remote Diode Temperatures, ±0.7°C (Typ), 0.06°C Resolution, I ² C Interface, PWM Output
LTC2995	Temperature Sensor and Voltage Monitor with Alert Outputs	Monitors Temperature and Two Voltages, Adjustable Thresholds, Open Drain Alert Outputs, Temperature to Voltage Output with Integrated 1.8V Reference, ±1°C (Max) Accuracy
LTC2997	Remote/Internal Temperature Sensor	Converts Remote Sensor or Int. Diode Temperature to Analog Voltage, Integrated 1.8V Reference, ±1°C (Max) Accuracy
LTC1077	Micropower, Single Supply, Precision Op Amp	60µA Supply Current, 40µV Offset, Low Noise

Looking for pricing, stock, or lifecycle information?

Click below to explore more details on WIN SOURCE:

- ⊖ [View LTC2996HDD#TRPBF on WIN SOURCE](#)
- ⊖ [Analog Devices Inc. Information](#)

Optimize Your Supply Chain with WIN SOURCE Solutions

- ✓ Global Sourcing Solution
- ✓ Obsolete Management
- ✓ Cost Control Management
- ✓ Shortage Management
- ✓ Alternative Solution
- ✓ Excess Inventory Management