

Single-chip Type with Built-in FET type Switching Regulators

Flexible Step-down Switching Regulator with Built-in Power MOSFET



BD8643FV

No.10027EAT43

●Description

The BD8643FV is a synchronous step-down switching regulator that integrates 2 low resistances N-channel MOSFETs. It achieves 3A continuous output current over a wide input supply range. Current mode operation provides fast transient response and easy phase compensation.

●Feature

- 1) Synchronous rectification with built-in FET type DC/DC converter
- 2) 2.0A output current
- 3) Range of operation power-supply voltage 4.5V~18V
- 4) Reference voltage FB 0.8V±1%
- 5) Programmable frequency 100kHz~600kHz
- 6) Over current protection function
- 7) Thermal shutdown function
- 8) Under voltage protection
- 9) Soft start time out function / Soft start delay circuit
- 10) Programmable OFFLATCH time

●Applications

FPD,DVD,HDD Recorder,STB,Amusement,Other

●Absolute maximum ratings (Ta=25°C)

Parameter	Symbol	Ratings	Unit
Input supply voltage	V _{IN}	20	V
BOOT terminal voltage	V _{BOOT}	28	V
EN terminal voltage	V _{EN}	GND-0.3 ~ V _{IN} +0.3	V
Input terminal voltage	V _{INP} ^{*1}	GND-0.3 ~ 7	V
SW terminal voltage	V _{SW}	GND-0.3 ~ V _{IN} +0.3	V
Output current	I _{OUT}	3.5	A
Power dissipation	P _d	1.19 ^{*2}	W
Operating temperature	T _{opr}	-20 ~ 85	°C
Storage temperature	T _{stg}	-55 ~ 150	°C

*1 VINP Application terminal: SS/DELAY, FB, FC, RT, PSET

*2 (70mm×70mm, thickness 1.6mm, and four layer glass epoxy substrates)When mounting substrate and the package back exposure part are connected with solder
Operating at higher than Ta=25°C, 9.5mW shall be reduced per 1

●Operating conditions

Parameter	Symbol	Ratings			Unit
		Min.	Typ.	Max.	
Input supply voltage	V _{IN}	4.5	-	18.0	V
Output current	I _{OUT}	-	-	3.0	A

* This product is not designed for protection against radioactive rays.

●Electrical characteristic

(Unless otherwise noted $T_a=25^{\circ}\text{C}$, $V_{\text{IN}}=12\text{V}$, $V_{\text{EN}}=3\text{V}$)

Parameter	Symbol	Limits			UNIT	Condition
		Min.	Typ.	Max.		
V_{IN} supply current (operating)	$I_{\text{Q_active}}$	-	1.5	2.5	mA	$V_{\text{FB}} = 0.75\text{V}$
V_{IN} supply current (standby)	$I_{\text{Q_stby}}$	-	0.8	1.2	mA	$V_{\text{EN}} = 0\text{V}$
Reference voltage (V_{REF})	V_{FB}	0.792	0.800	0.808	V	FB-FC Short
Oscillation frequency	f_{OSC}	270	300	330	kHz	$R_{\text{RT}} = 56\text{k}\Omega$
High side FET ON resistance	R_{HFET}	-	120	170	m Ω	$I_{\text{SW}} = -1\text{A}$
Low side FET ON resistance	R_{LFET}	-	120	170	m Ω	$I_{\text{SW}} = 1\text{A}$
UVLO voltage	V_{UVLO}	3.8	4.0	4.2	V	V_{IN} Sweep
SW leak current	I_{LSW}	-	0	5	μA	$V_{\text{EN}} = 0\text{V}$
EN terminal H threshold voltage	V_{ENH}	1.6	-	-	V	
EN terminal L threshold voltage	V_{ENL}	-	-	0.4	V	
SS/DELAY terminal source current	I_{SSSO}	2.8	4.0	5.2	μA	$V_{\text{SS}} = 1\text{V}$
SS/DELAY – FB Offset voltage	V_{SSFBOST}	450	600	750	mV	$V_{\text{SS}} = 1\text{V}$
PSET terminal source current	I_{PSET}	3.0	5.0	7.0	μA	$V_{\text{PSET}} = 2\text{V}$
PSET terminal threshold voltage	V_{PSET}	0.8	1.0	1.2	V	

- V_{FB} :FB terminal voltage, V_{EN} :EN terminal voltage, V_{SS} :SS/DELAY terminal voltage, V_{PSET} :PSET terminal voltage, R_{RT} :RT resistor
- Current capability should not exceed Pd.

● Reference data

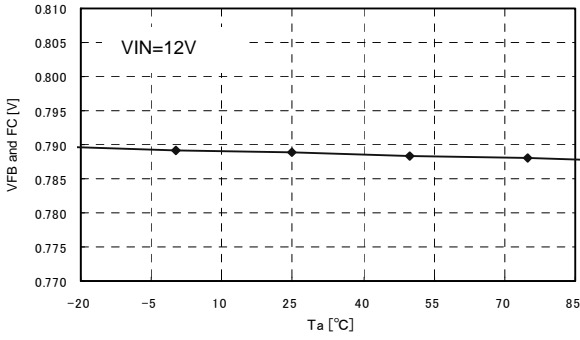

Fig.1 Reference voltage – temperature characteristic

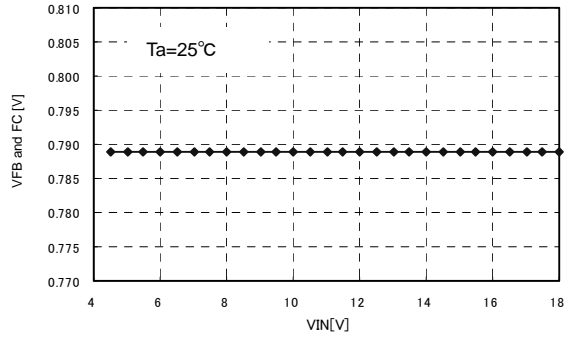

Fig.2 Reference voltage – VIN characteristic

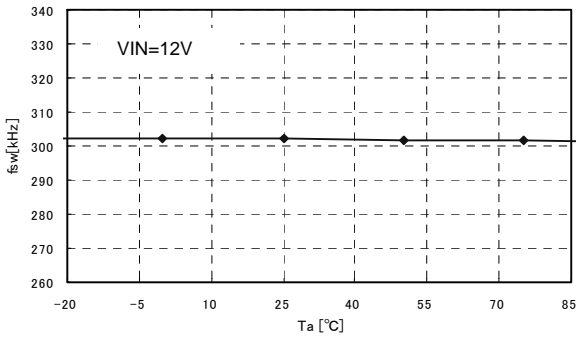

Fig.3 Frequency – temperature characteristic

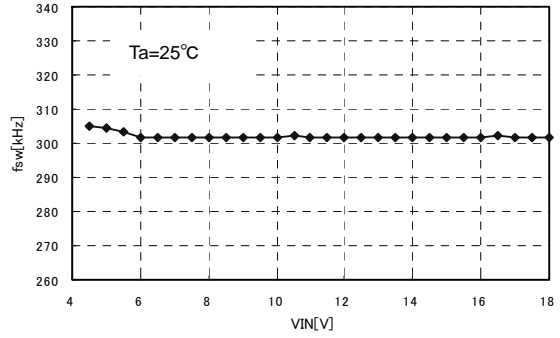

Fig.4 Frequency – VIN characteristic

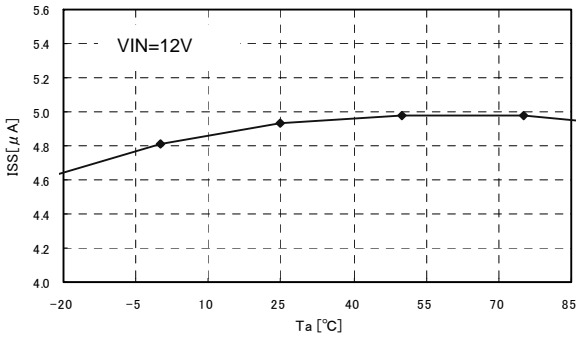

Fig.5 SS/DELAY charge current - temperature characteristic

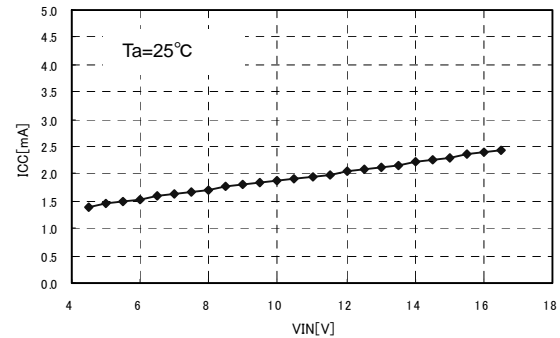

Fig.6 Circuit Current – VIN characteristic

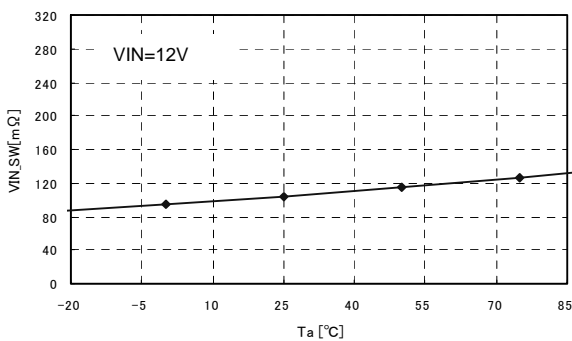

Fig.7 Hi side FET ON_R - temperature characteristic

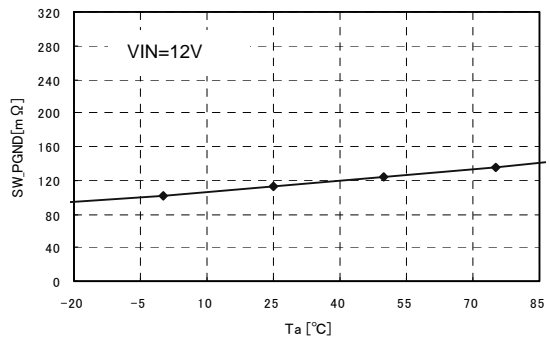

Fig.8 Low side FET ON_R - temperature characteristic

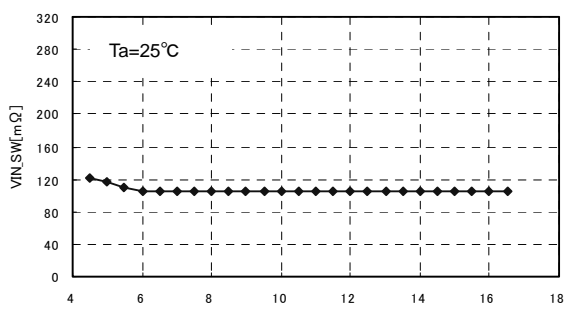

Fig.9 Hi side FET ON_R - VIN characteristic

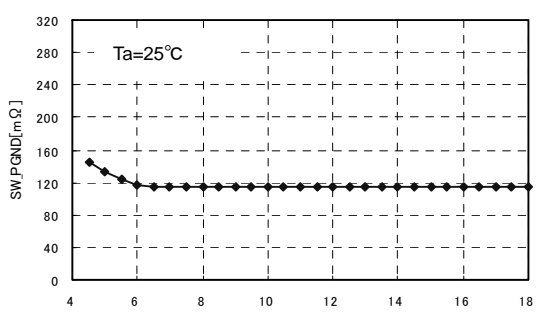

Fig.10 Low side FET ON_R – VIN characteristic

●Block Diagram

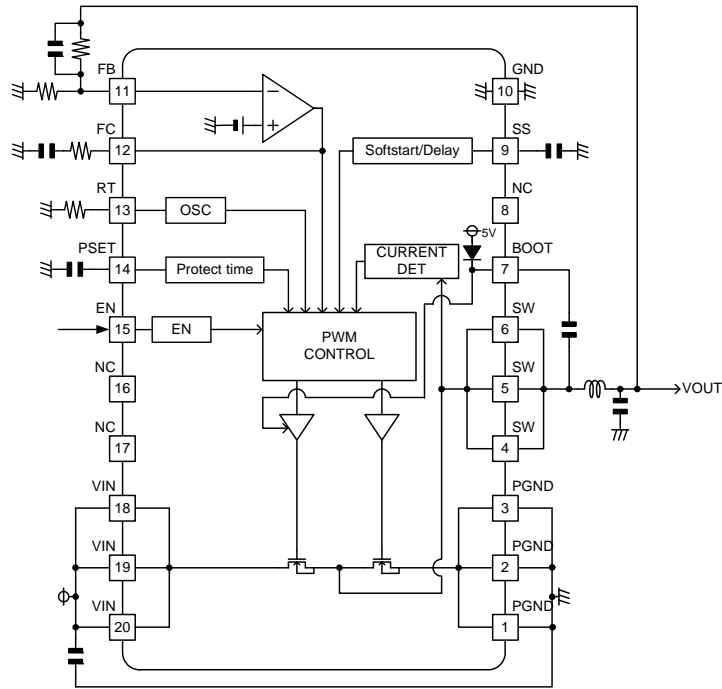
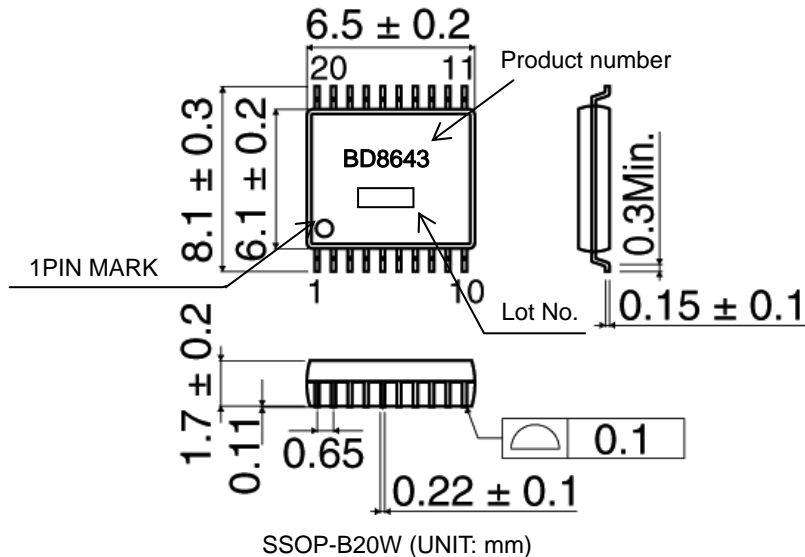

Fig.11 Block diagram

●terminal assignment

No.	Symbol	Description	No.	Symbol	Description
1	PGND	Power GND terminal	11	FB	Feedback terminal
2	PGND	Power GND terminal	12	FC	Phase amends terminal
3	PGND	Power GND terminal	13	RT	Frequency adjustment resistance connection terminal
4	SW	Switching output terminal	14	PSET	Adjust OFF LATCH time terminal
5	SW	Switching output terminal	15	EN	Enable input
6	SW	Switching output terminal	16	NC	-
7	BOOT	Boot strap terminal	17	NC	-
8	NC	-	18	VIN	Power supply input terminal
9	SS/DELAY	Soft start adjustment capacity connection terminal	19	VIN	Power supply input terminal
10	GND	Signal GND terminal	20	VIN	Power supply input terminal

●Package outline dimension



SSOP-B20W (UNIT: mm)

●Operation description

1 Enable control

The device can be controlled ON/OFF by EN terminal (15 pin) voltage.

An internal circuit starts when VEN reaches 1.4V.

When standing up of VIN is too steep (1msec or less), a defective start might be caused according to the state of Pascon between GND substrate pattern and power supply-when the terminal EN is short-circuited to the terminal VIN and it is used.

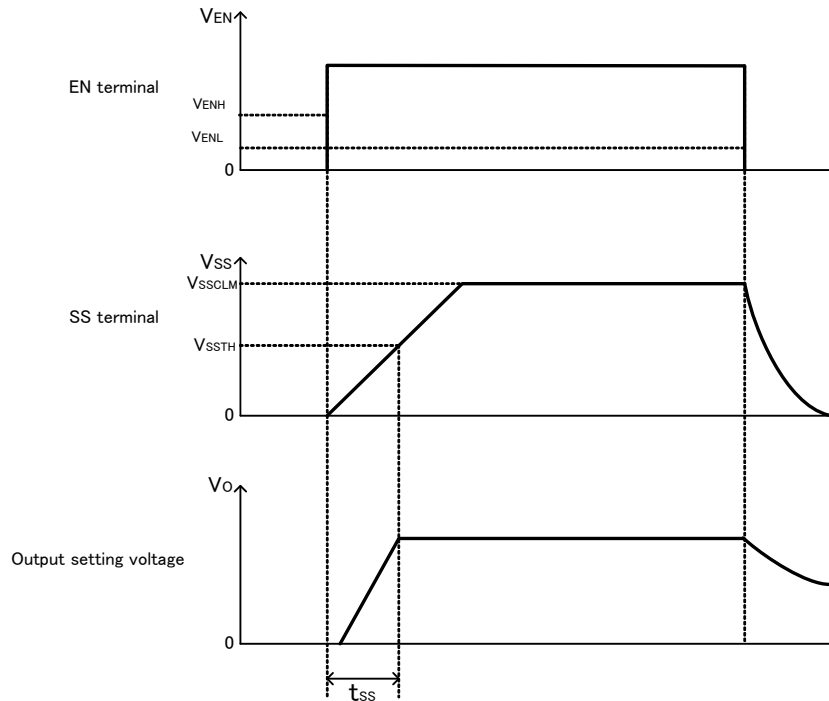

Fig.12 ON/OFF transition wave form in EN controlling

2 Soft start time set function

As for BD8643FV, output can do soft start without overshoot by charging soft start capacity (C_{SS}) connected between SS/DELAY (9 pin) and GND (10 pin) terminal.

Also, soft start time (t_{SS}) can be set by setting soft start capacity (C_{SS}) arbitrarily.(Refer to 5-2 soft start time setting method)

3 OSC oscillation frequency setting function

The output oscillation frequency can be set by connecting resistance between terminal RT (13 pin) and GND (range = 100kHz – 600kHz)

The relation between RT terminal resistance and the oscillation frequency follows Fig.13.

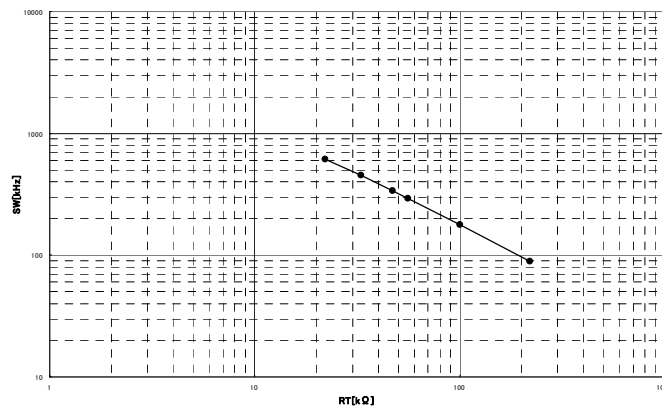

Fig.13 Oscillation frequency setting by RT resistance

●Protection function

Protection circuit is effective for destruction prevention due to accident so that avoid using under continuous protection operation.

1 Low voltage protection function (LVP)

The voltage of the terminal FB (11pin) is compared with internal reference voltage VREF.
 If FB terminal voltage falls below $V_{LVP}(= VREF -120mV)$ and the state continues, output changes to low voltage and the state is fixed.

Table 1 output low voltage protection function

EN terminal	SS terminal	FB terminal	Low voltage Protection function	Low voltage Protection operation
$>V_{ENH}$	$>1.4V(\text{typ})$	$<V_{LVP}$	Effective	ON
		$>V_{LVP}$		OFF
$<V_{ENL}$	$<1.4V(\text{typ})$	-	Invalidity	OFF
	-	-	Invalidity	OFF

※ Low voltage protection function is available when SS terminal voltage becomes more than 1.4V (typ) in the transition to ON control (during soft start).

2 Over voltage protection function (OVP)

The voltage of the terminal FB is compared with internal reference voltage VREF.
 If FB terminal voltage is over $V_{ovp}(=VREF +120mV)$ and the state is continues, output changes to low voltage and the state is fixed.

Table 2 output low voltage protection function

EN terminal	SS terminal	FB terminal	Low voltage Protection function	Low voltage Protection operation
$>V_{ENH}$	$>1.4V(\text{typ})$	$>V_{OVP}$	Effective	ON
		$<V_{OVP}$		OFF
$<V_{ENL}$	$<1.4V(\text{typ})$	-	Invalidity	OFF
	-	-	Invalidity	OFF

※ Over voltage protection function is available when SS terminal voltage becomes more than 1.4V (typ) in the transition to ON control (during soft start).

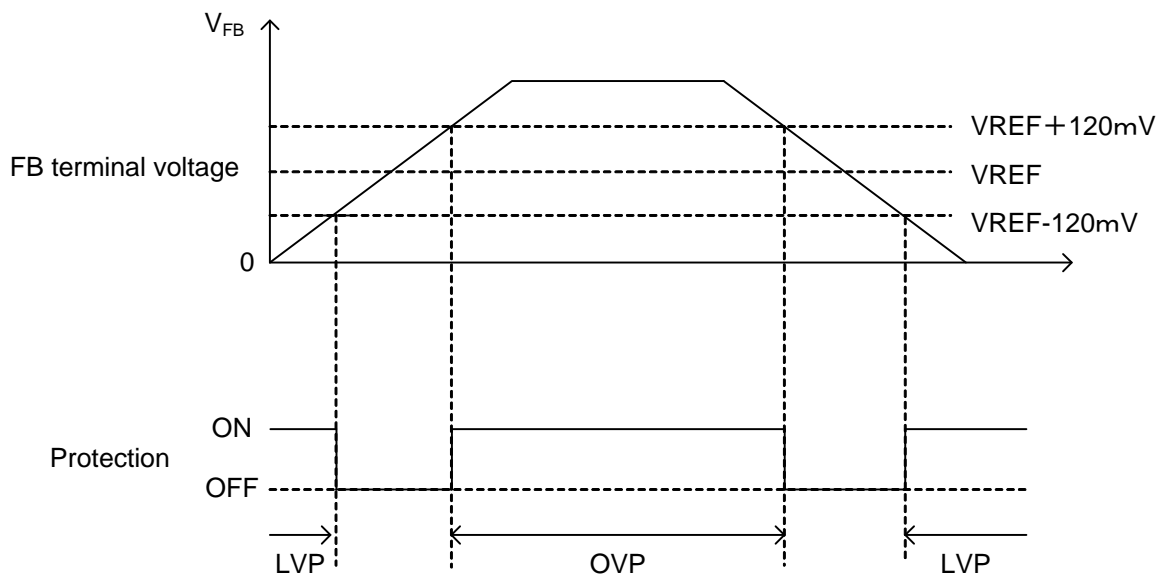

Fig.14 Output voltage error detection range

3 Under voltage lock out protection (UVLO)

As for BD8643FV, the power-supply voltage decrease detection protection circuit is built in. If the input voltage decrease below the UVLO voltage (4.0V typ), the device state changes to the standby mode (Moreover, to prevent the chattering of the output) hysteresis width of 300mV(typ) has been installed in the UVLO cancel voltage.

4 RT terminal open/short protection function (RTO/RTS)

RT terminal opening/short protection function prevent the clock from abnormal oscillation. If RT terminal open/short protection function is detected, output voltage changes to low level and is fixed.

5 Soft start time-out function

If VSS doesn't exceed VSSTH within 64msec (typ) since a soft start began, BD8643FV controls an off latch. Vo is fixed in a low level.

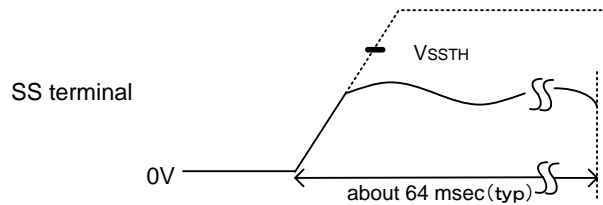

Fig.15 Soft start time-out

6 Thermal shut down function

Thermal shut down circuit (TSD circuit) is built into BD8643FV. When the temperature of the chip exceeds $T_{jmax}=175$, the DC/DC converter is fixed in a low voltage. TSD function is aimed to shut down IC from thermal reckless driving under an abnormal state to exceed $T_{jmax}=175$. It aims at neither protection nor the guarantee of the set. Therefore, please do not use this function to protect the set.

7 Over current protection function

The over current protection function has been achieved by limiting the current that flows on high side MOSFET. The current is controlled in every one cycle of the switching frequency. When an abnormal state continues, the output is fixed in a low level.

8 Error detection (off latch) release method

BD8643FV enters the state of an off latch when the protection function operates. To release the off latch state, VIN terminal voltage should be changed to less than UVLO level (=4.0V [typ]) once time.

●External parts setting method

1 Output voltage setting method

The output voltage can be arbitrarily set by external resistance.

$$V_o = \frac{(R1+R2)}{R2} V_{REF}$$

Please select the constant of R1 and R2 by this expression.

Please select the current that flows to R1 and R2 to become much smaller than output current.

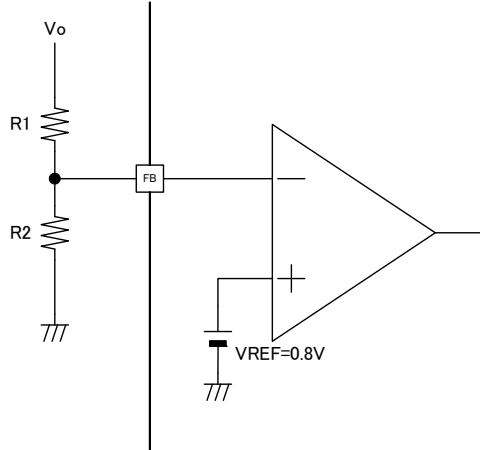

Fig.16 Output voltage setting circuit

2 Soft start time setting method

BD8643FV can soft start without overshoot because of a charge current to the soft start capacitance (CSS).

The soft start time can be set by connecting soft start capacity (CSS).

When the EN terminal voltage is set VIN_EN or more, the charge to the capacity between SS/DELAY and GND terminal is begun. The output voltage becomes soft start in proportion to a SS/DELAY terminal voltage rising. When the SS/DELAY terminal voltage exceeds VSSTH, the output voltage is fixed in a setting value.

Please set soft start time (tss) in 1msec-52.5msec.

$$T_{VO} = \underbrace{TW_{EN}(= 50\mu s)}_{\text{①}} + \underbrace{\frac{V_{OST}(= 0.6V) \times C_{SS}}{I_{SS}(= 4\mu A)}}_{\text{②}} + \underbrace{\frac{(V_{SSTH} - V_{OST}) \times C_{SS}}{I_{SS}(= 4\mu A)}}_{\text{③}}$$

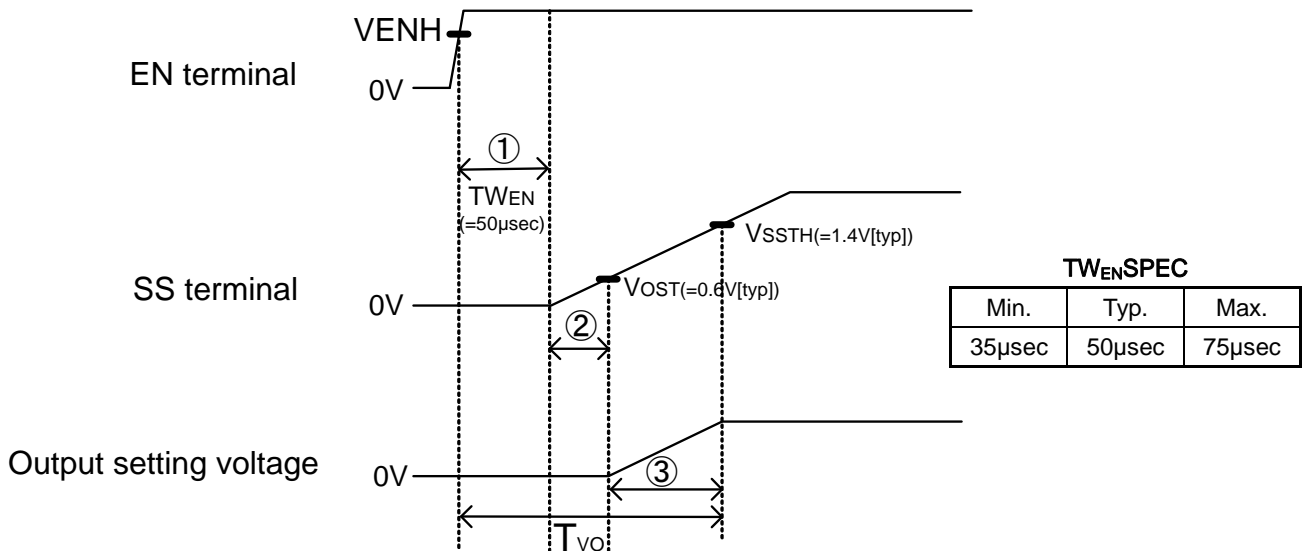

Fig.17 Soft start

3 Selection of inductor (L)

Please select the value of the inductor according to the following expressions.

$$L = \frac{(V_{IN} - V_{OUT}) \times V_{OUT}}{\Delta I_L \times V_{IN} \times f} \text{ [H]}$$

(ΔI_L : Output ripple current, f: Switching frequency)

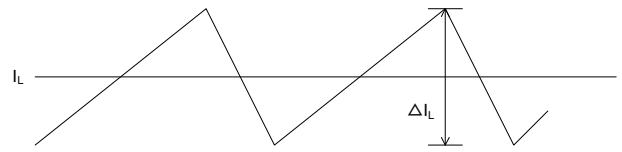

Fig.18 Current of output ripple

※Please have and select an enough margin so that the current peak should not exceed the ratings current value of the inductor.

4 Selection of input capacitor (Cin)

Please use a low ESR input capacitor which can be used with high voltage and ripple current to prevent a big transition voltage.

※Please put on the input capacitor near side by VIN-PGND.

5 Selection of diode

Please have and set the margin enough to the current rating of the diode for the maximum load current. Moreover, please similarly have and set the margin enough to a ratings reverse-voltage for the maximum input voltage.

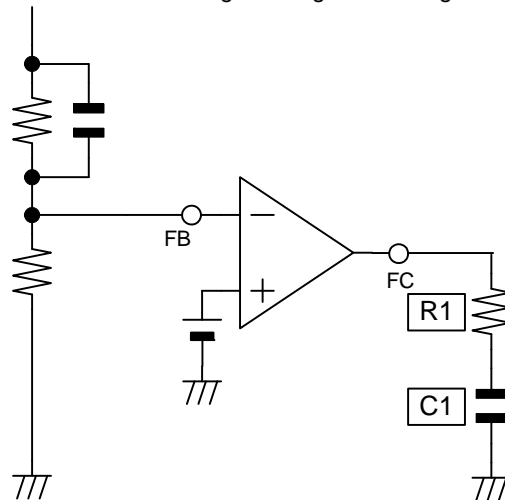

Fig.19 Phase amends part external circuit chart

6 OFFLATCH time setting method

If it continues abnormal state, BD8643FV output become low voltage and state is fixed.

In this case, the OFFLATCH time can be set by connecting capacitor between PSET and GND. Please select the value of OFFLATCH time according to the following expression. Please set OFFLATCH time in 200μsec~5msec.

$$T_{TM} = \frac{C_{PSET}}{I_{PSET}(5\mu A \text{ typ})} \text{ [sec]} \cdot \cdot \cdot (11)$$

To release the off latch state, EN or VIN terminal voltage should be changed to low level once time.

● Typical application circuit

【Condition】

VOUT = 1.2V
fosc = 300kHz
OFFLATCH time = 500μsec

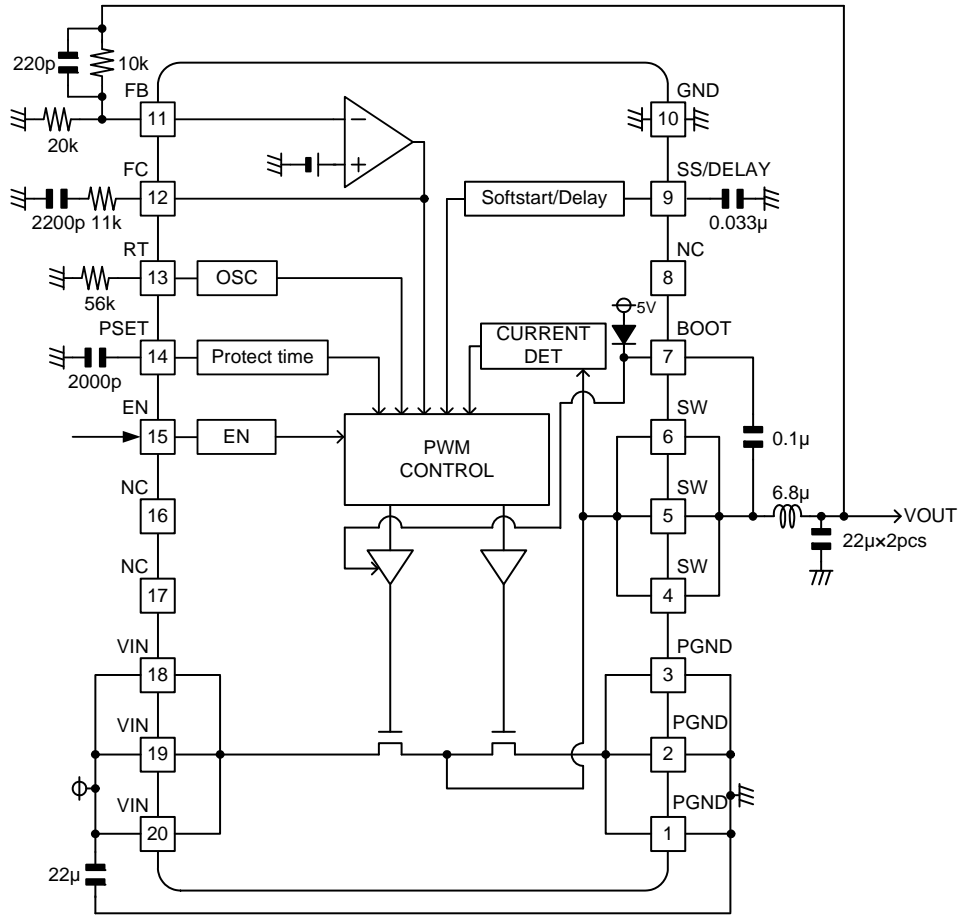
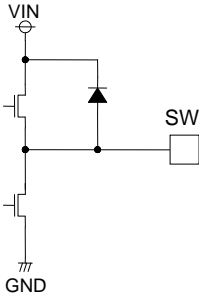
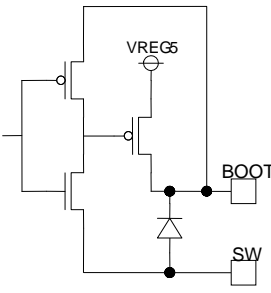
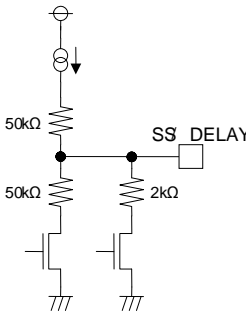
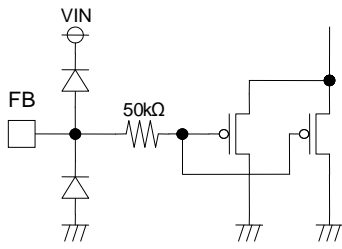
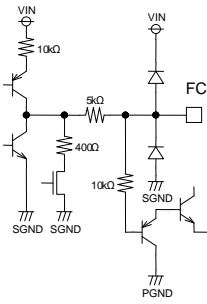
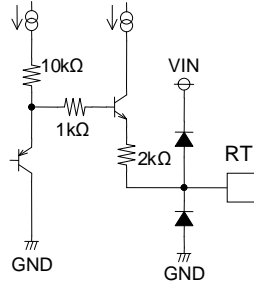
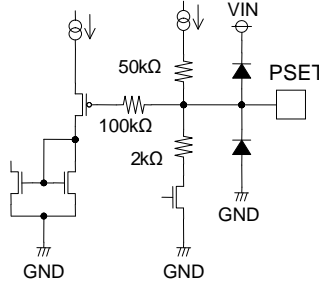
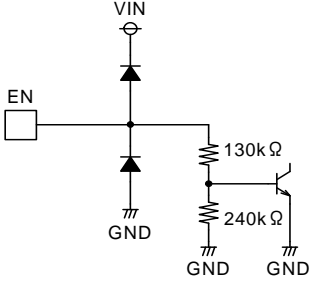

Fig.20 Typical application

● I/O equivalence circuit

4, 5, 6PIN(SW)	7PIN(BOOT)	9PIN(SS/DELAY)
		
11PIN(FB)	12PIN(FC)	13PIN(RT)
		
14PIN(PSET)	15PIN(EN)	
		

●Note for use

1. About the absolute maximum rating
Attention is brushed off enough to the quality control, it is likely to destroy when the absolute maximum rating such as impressed voltages (VCC_IN,DCIN) and ranges (Topr) of the operating temperature as it is exceeded, the mode of breakings of the short or the opening, etc. cannot be specified, and examine it in this IC to give physical measures for safety such as fuses when a special mode that exceeds the absolute maximum rating is assumed.
2. GND pin voltage
GND terminal should be connected the lowest voltage, under all conditions. And all terminals except SW should be under GND terminal voltage under all conditions including transient situations. If a terminal exists under GND, it should be inserting a bypass route.
3. Power dissipation
If IC is used on condition that the power loss is over the power dissipation, the reliability will become worse by heat up, such as reduced output current capability. Also, be sure to use this IC within a power dissipation range allowing enough of margin.
4. Input supply voltage
Input supply pattern layout should be as short as possible.
5. About the short and the miss-installation between terminals
Note the direction and the miss-registration of IC enough when you install it in the set substrate. IC might destroy it as well as reversely connecting the power supply connector when installing it by mistake. Moreover, there is fear of destruction when the foreign body enters between terminals, the terminal, the power supply, and grandeur and it is short-circuited.
6. About operation in strong electromagnetic field
In use in strong electromagnetic field, note that there is a possibility of malfunctioning.
7. About the inspection by the set substrate
It is likely to suffer stress to IC and discharge electricity every one process when you connect the capacitor with the pin with low impedance when inspecting it in the set substrate. Moreover, detach it after connecting after the power supply is turned off without fail when detaching it to G in the inspection process, inspecting, and turning off the power supply. In addition, be give the earth to the assembly process as a static electricity measures, and careful enough when it transports and you preserve it.
8. About each input terminal

This IC is a monolithic IC which has a P⁺ isolations and P substrate to isolate elements each other.

This P layer and an N layer in each element form a PN junction to construct various parasitic elements.

For instance, the potential difference operates in resistance as shown in the figure below when resistance and the playground connect it with the terminal and the playground (GND) >(terminal B) joint of PN operates as a parasitic diode in playground (GND) >(terminal A) transistor (NPN). In addition, the NPN transistor of parasitism works with N layer of the element of the above-mentioned parasitic diode and the neighborhood and others in transistor (NPN). A parasitic element in IC composition is inevitably formed because of the potential relation.

A parasitic element can operate, the interference with the circuit operation be caused, it malfunction, and, consequently, it cause destruction. Therefore, do not do the usage that a parasitic element operates as a voltage that is lower than the playground (GND;P substrate) is impressed to the input terminal enough. Moreover, do not impress the voltage to the input terminal when you do not impress the power-supply voltage to IC. Give each input terminal to me the voltage below the power-supply voltage or in the guarantee value of an electric characteristic when you similarly impress the power-supply voltage.

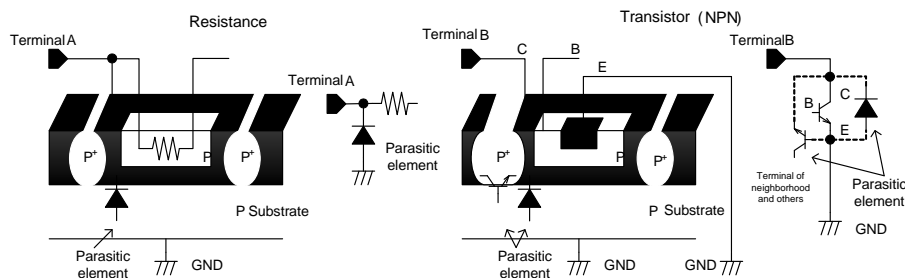

Example of IC of simple structure

9. Earth wiring pattern
If small signal GND and large current GND exist, disperse their pattern. In addition, for voltage change by pattern wiring impedance and large current not to change voltage of small signal GND, each ground terminal of IC must be connected at the one point on the set circuit board. As for GND of external parts, it is similar to the above-mentioned.
10. About each output terminal
We recommend to put Diode for protection purpose in case of output pin connected with large load of impedance or reserve current occurred at initial and output off.
11. Thermal Shut Down Circuit
A temperature control is built in the IC to prevent the damage due to overheat. Therefore, the outputs are turned off when the thermal circuit works.
12. Over Output Current Protection
SW Output terminal has over current protection circuit of 5A, with prevents IC from being damage by short circuit at over current. However, It is recommend not to use that continuously operates the protection circuit (For instance, always the load that greatly exceeds the output current ability is connected or the output is short-circuited, etc.) in these protection circuits by an effective one to the destruction prevention due to broken accident.

●Ordering part number

B	D
---	---

Part No.

8	6	4	3
---	---	---	---

Part No.

F	V
---	---

Package
F: SSOP-B20W

E	2
---	---

Packaging and forming specification
E2: Embossed tape and reel

SSOP-B20W

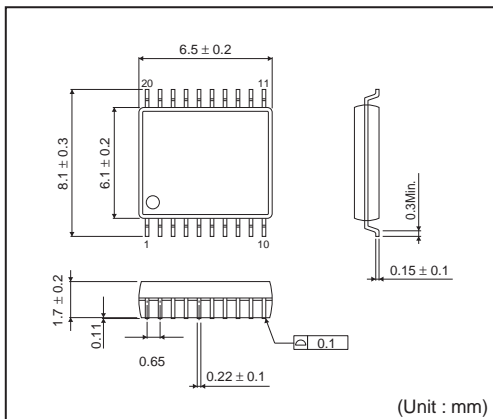

<Tape and Reel information>

Tape	Embossed carrier tape
Quantity	2000pcs
Direction of feed	E2 (The direction is the 1pin of product is at the upper left when you hold reel on the left hand and you pull out the tape on the right hand)

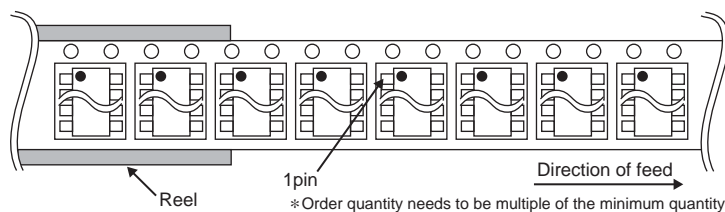

Notice

Precaution on using ROHM Products

- Our Products are designed and manufactured for application in ordinary electronic equipments (such as AV equipment, OA equipment, telecommunication equipment, home electronic appliances, amusement equipment, etc.). If you intend to use our Products in devices requiring extremely high reliability (such as medical equipment ^(Note 1), transport equipment, traffic equipment, aircraft/spacecraft, nuclear power controllers, fuel controllers, car equipment including car accessories, safety devices, etc.) and whose malfunction or failure may cause loss of human life, bodily injury or serious damage to property ("Specific Applications"), please consult with the ROHM sales representative in advance. Unless otherwise agreed in writing by ROHM in advance, ROHM shall not be in any way responsible or liable for any damages, expenses or losses incurred by you or third parties arising from the use of any ROHM's Products for Specific Applications.

(Note1) Medical Equipment Classification of the Specific Applications

JAPAN	USA	EU	CHINA
CLASS III	CLASS III	CLASS II b	CLASS III
CLASS IV		CLASS III	

- ROHM designs and manufactures its Products subject to strict quality control system. However, semiconductor products can fail or malfunction at a certain rate. Please be sure to implement, at your own responsibilities, adequate safety measures including but not limited to fail-safe design against the physical injury, damage to any property, which a failure or malfunction of our Products may cause. The following are examples of safety measures:
 - Installation of protection circuits or other protective devices to improve system safety
 - Installation of redundant circuits to reduce the impact of single or multiple circuit failure
- Our Products are designed and manufactured for use under standard conditions and not under any special or extraordinary environments or conditions, as exemplified below. Accordingly, ROHM shall not be in any way responsible or liable for any damages, expenses or losses arising from the use of any ROHM's Products under any special or extraordinary environments or conditions. If you intend to use our Products under any special or extraordinary environments or conditions (as exemplified below), your independent verification and confirmation of product performance, reliability, etc. prior to use, must be necessary:
 - Use of our Products in any types of liquid, including water, oils, chemicals, and organic solvents
 - Use of our Products outdoors or in places where the Products are exposed to direct sunlight or dust
 - Use of our Products in places where the Products are exposed to sea wind or corrosive gases, including Cl₂, H₂S, NH₃, SO₂, and NO₂
 - Use of our Products in places where the Products are exposed to static electricity or electromagnetic waves
 - Use of our Products in proximity to heat-producing components, plastic cords, or other flammable items
 - Sealing or coating our Products with resin or other coating materials
 - Use of our Products without cleaning residue of flux (even if you use no-clean type fluxes, cleaning residue of flux is recommended); or Washing our Products by using water or water-soluble cleaning agents for cleaning residue after soldering
 - Use of the Products in places subject to dew condensation
- The Products are not subject to radiation-proof design.
- Please verify and confirm characteristics of the final or mounted products in using the Products.
- In particular, if a transient load (a large amount of load applied in a short period of time, such as pulse. is applied, confirmation of performance characteristics after on-board mounting is strongly recommended. Avoid applying power exceeding normal rated power; exceeding the power rating under steady-state loading condition may negatively affect product performance and reliability.
- De-rate Power Dissipation (Pd) depending on Ambient temperature (Ta). When used in sealed area, confirm the actual ambient temperature.
- Confirm that operation temperature is within the specified range described in the product specification.
- ROHM shall not be in any way responsible or liable for failure induced under deviant condition from what is defined in this document.

Precaution for Mounting / Circuit board design

- When a highly active halogenous (chlorine, bromine, etc.) flux is used, the residue of flux may negatively affect product performance and reliability.
- In principle, the reflow soldering method must be used; if flow soldering method is preferred, please consult with the ROHM representative in advance.

For details, please refer to ROHM Mounting specification

Precautions Regarding Application Examples and External Circuits

1. If change is made to the constant of an external circuit, please allow a sufficient margin considering variations of the characteristics of the Products and external components, including transient characteristics, as well as static characteristics.
2. You agree that application notes, reference designs, and associated data and information contained in this document are presented only as guidance for Products use. Therefore, in case you use such information, you are solely responsible for it and you must exercise your own independent verification and judgment in the use of such information contained in this document. ROHM shall not be in any way responsible or liable for any damages, expenses or losses incurred by you or third parties arising from the use of such information.

Precaution for Electrostatic

This Product is electrostatic sensitive product, which may be damaged due to electrostatic discharge. Please take proper caution in your manufacturing process and storage so that voltage exceeding the Products maximum rating will not be applied to Products. Please take special care under dry condition (e.g. Grounding of human body / equipment / solder iron, isolation from charged objects, setting of ionizer, friction prevention and temperature / humidity control).

Precaution for Storage / Transportation

1. Product performance and soldered connections may deteriorate if the Products are stored in the places where:
 - [a] the Products are exposed to sea winds or corrosive gases, including Cl₂, H₂S, NH₃, SO₂, and NO₂
 - [b] the temperature or humidity exceeds those recommended by ROHM
 - [c] the Products are exposed to direct sunshine or condensation
 - [d] the Products are exposed to high Electrostatic
2. Even under ROHM recommended storage condition, solderability of products out of recommended storage time period may be degraded. It is strongly recommended to confirm solderability before using Products of which storage time is exceeding the recommended storage time period.
3. Store / transport cartons in the correct direction, which is indicated on a carton with a symbol. Otherwise bent leads may occur due to excessive stress applied when dropping of a carton.
4. Use Products within the specified time after opening a humidity barrier bag. Baking is required before using Products of which storage time is exceeding the recommended storage time period.

Precaution for Product Label

QR code printed on ROHM Products label is for ROHM's internal use only.

Precaution for Disposition

When disposing Products please dispose them properly using an authorized industry waste company.

Precaution for Foreign Exchange and Foreign Trade act

Since our Products might fall under controlled goods prescribed by the applicable foreign exchange and foreign trade act, please consult with ROHM representative in case of export.

Precaution Regarding Intellectual Property Rights

1. All information and data including but not limited to application example contained in this document is for reference only. ROHM does not warrant that foregoing information or data will not infringe any intellectual property rights or any other rights of any third party regarding such information or data. ROHM shall not be in any way responsible or liable for infringement of any intellectual property rights or other damages arising from use of such information or data.:
2. No license, expressly or implied, is granted hereby under any intellectual property rights or other rights of ROHM or any third parties with respect to the information contained in this document.

Other Precaution

1. This document may not be reprinted or reproduced, in whole or in part, without prior written consent of ROHM.
2. The Products may not be disassembled, converted, modified, reproduced or otherwise changed without prior written consent of ROHM.
3. In no event shall you use in any way whatsoever the Products and the related technical information contained in the Products or this document for any military purposes, including but not limited to, the development of mass-destruction weapons.
4. The proper names of companies or products described in this document are trademarks or registered trademarks of ROHM, its affiliated companies or third parties.

General Precaution

1. Before you use our Products, you are requested to carefully read this document and fully understand its contents. ROHM shall not be in any way responsible or liable for failure, malfunction or accident arising from the use of any ROHM's Products against warning, caution or note contained in this document.
2. All information contained in this document is current as of the issuing date and subject to change without any prior notice. Before purchasing or using ROHM's Products, please confirm the latest information with a ROHM sales representative.
3. The information contained in this document is provided on an "as is" basis and ROHM does not warrant that all information contained in this document is accurate and/or error-free. ROHM shall not be in any way responsible or liable for any damages, expenses or losses incurred by you or third parties resulting from inaccuracy or errors of or concerning such information.

Looking for pricing, stock, or lifecycle information?

Click below to explore more details on WIN SOURCE:

- [View BD8643FV-E2 on WIN SOURCE](#)
- [Rohm Semiconductor Information](#)

Optimize Your Supply Chain with WIN SOURCE Solutions

- ✓ Global Sourcing Solution
- ✓ Obsolete Management
- ✓ Cost Control Management
- ✓ Shortage Management
- ✓ Alternative Solution
- ✓ Excess Inventory Management