



**THE DATASHEET OF
SG723J-JAN**



Precision Voltage Regulator

Description

This monolithic voltage regulator is designed for use with either positive or negative supplies as a series, shunt, switching, or floating regulator with currents up to 150 mA. Higher current requirements may be accommodated through the use of external NPN or PNP power transistors. This device consists of a temperature compensated reference amplifier, error amplifier, power series pass transistor, current limit, and remote shutdown circuitry.

The SG723 will operate over the full military ambient temperature range of -55°C to 125°C.

Features

- Positive or Negative Supply Operation
- Series, Shunt, Switching or Floating Operation
- Low Line and Load Regulation
- Output Adjustable from 2 V to 37 V
- Output Current to 150 mA
- Low Standby Current Drain
- 0.002%/°C Average Temperature Variation

High Reliability Features

- MIL-M38510/10201BHA - SG723F-JAN
- MIL-M38510/10201BIA - SG723T-JAN
- MIL-M38510/10201BCA - SG723J-JAN
- MSC-AMS Level "S" Processing Available

Block Diagram

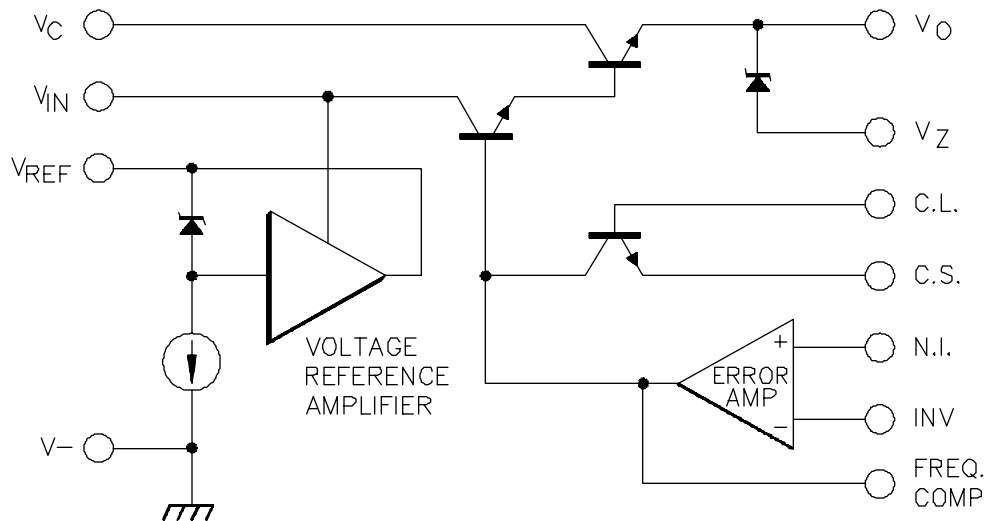

Absolute Maximum Ratings (Note 1)

Pulse (50 ms) Input Voltage from V_{IN} to V_-	50 V	Current from V_{REF}	15 mA
Continuous Input Voltage from V_{IN} to V_-	40 V	Operating Junction Temperature	
Input to Output Voltage Differential	40 V	Hermetic (T, J, F - Packages).....	150°C
Maximum Output Current	150 mA	Storage Temperature Range	-65°C to 150°C
Current from V_Z (J-Package only).....	25 mA	Lead Temperature (Soldering, 10 s).....	300°C

Note 1. Exceeding these ratings could cause damage to the device.

Thermal Data

J Package:

Thermal Resistance-Junction to Case, θ_{JC}	30°C/W
Thermal Resistance-Junction to Ambient, θ_{JA}	80°C/W

T Package:

Thermal Resistance-Junction to Case, θ_{JC}	25°C/W
Thermal Resistance-Junction to Ambient, θ_{JA}	130°C/W

F Package:

Thermal Resistance-Junction to Case, θ_{JC}	80°C/W
Thermal Resistance-Junction to Ambient, θ_{JA}	145°C/W

Note A. Junction Temperature Calculation: $T_J = T_A + (P_D \times \theta_{JA})$.

Note B. The above numbers for θ_{JC} are maximums for the limiting thermal resistance of the package in a standard mounting configuration. The θ_{JA} numbers are meant to be guidelines for the thermal performance of the device/pc-board system. All of the above assume no ambient airflow.

Recommended Operating Conditions (Note 2)

Input Voltage Range	($V_{OUT} + 4.5 V$) to 38 V	Zener Current (J-Package only).....	5 mA
Output Current Range	5 mA to 45 mA	Operating Ambient Temperature Range	
Reference Current.....	5 mA	SG723	-55°C to 125°C

Note 2. Range over which the device is functional.

Electrical Characteristics

(Unless otherwise specified, these specifications apply for the operating ambient temperature of $T_A = 25^\circ\text{C}$, $V_{IN} = V_C = 12\text{ V}$, $V_- = 0\text{ V}$, $V_{OUT} = 5\text{ V}$, $I_L = 1\text{ mA}$, $R_{SC} = 0\ \Omega$, $C_1 = 100\text{ pF}$, and divider impedance as seen by error amplifier $\leq 10\text{ k}\Omega$. Low duty cycle pulse testing techniques are used which maintains junction and case temperatures equal to the ambient temperature.)

Parameter	Test Conditions	SG723			Units
		Min.	Typ.	Max.	
Input Voltage Range		9.5		40	V
Output Voltage Range		2.0		37	V
Input to Output Differential		3.0		38	V
Line Regulation (Note 3)	$V_{IN} = 12\text{ V to }15\text{ V}$ $T_A = T_{MIN} \text{ to } T_{MAX}$ $V_{IN} = 12\text{ V to }40\text{ V}$		0.01	0.1	% V_{OUT}
				0.3	% V_{OUT}
Load Regulation (Note 3)	$I_L = 1 \text{ to } 50\text{ mA}$ $T_A = T_{MIN} \text{ to } T_{MAX}$		0.02	0.2	% V_{OUT}
			0.03	0.15	% V_{OUT}
Ripple Rejection	$f = 50\text{ Hz to }10\text{ kHz}$ $C_{REF} = 0$			0.6	% V_{OUT}
	$C_{REF} = 5\ \mu\text{F}$		74		dB
Temperature Stability (Note 4)	$T_A = T_{MIN} \text{ to } T_{MAX}$		86		dB
Short Circuit Current Limit	$R_{SC} = 10\ \Omega$		0.002	0.015	%/ $^\circ\text{C}$
Reference Voltage		6.95	7.15	7.35	mA
Output Noise Voltage	$BW = 100\text{ Hz to }10\text{ kHz}$				V
	$C_{REF} = 0$		20		μV_{rms}
	$C_{REF} = 5\ \mu\text{F}$		2.5		μV_{rms}
Standby Current Drain	$I_L = 0, V_{IN} = 30\text{ V}$		2.3	3.5	mA
Long Term Stability			0.1		%/khr

Note 3. Applies for constant junction temperature. Temperature drift effects must be taken into account separately when the unit is operating under conditions of high dissipation.

Note 4. These parameters, although guaranteed, are not tested in production.

Characteristic Curves

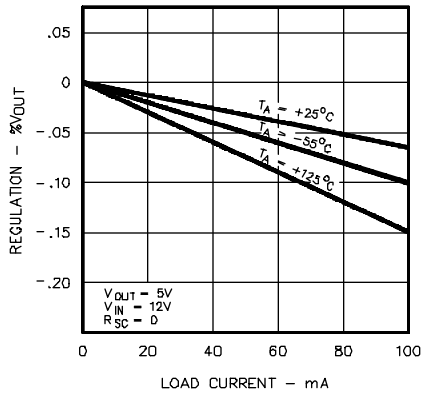

Figure 1. Load Regulation

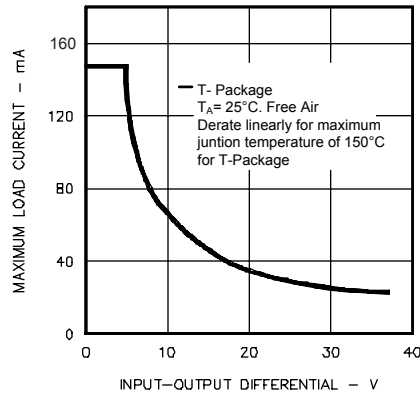

Figure 2. Maximum Load Current

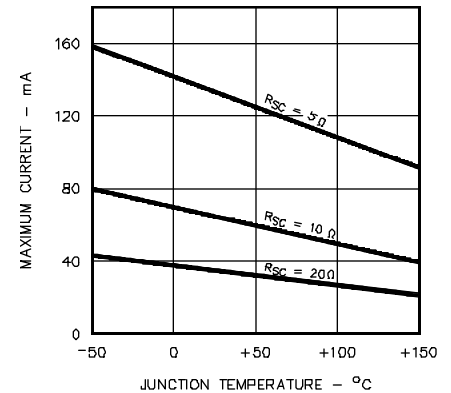

Figure 3. Current Limiting Characteristics

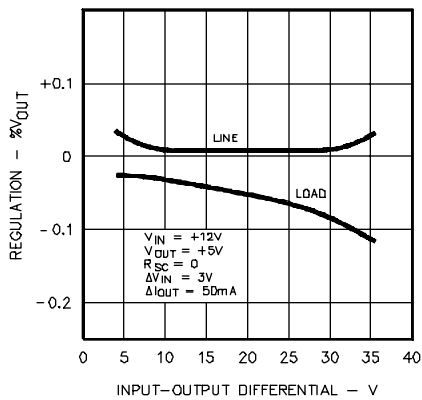

Figure 4. Regulations vs. Input-Output Voltage Regulation

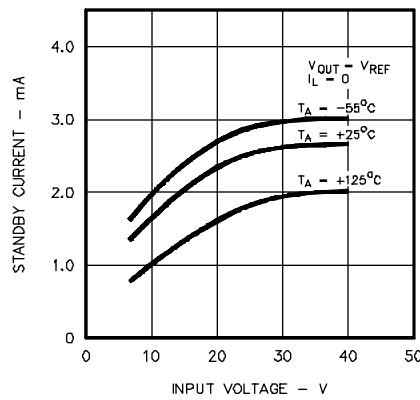

Figure 5. Standby Current Drain

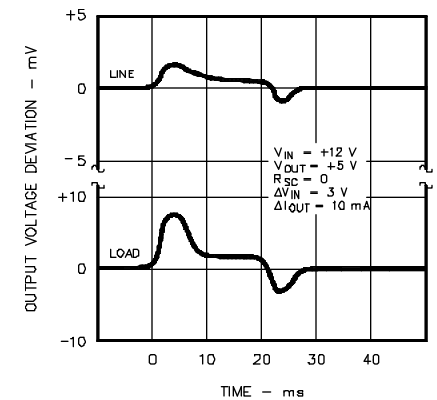

Figure 6. Transient Response

Application Information

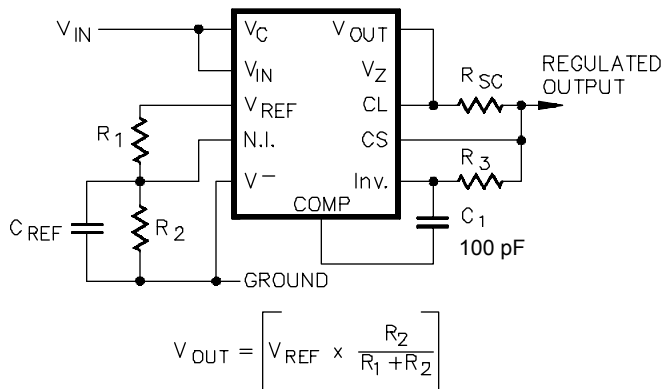

Figure 7 - Basic Low Voltage Regulator $V_{OUT} = 2 \text{ V TO } 7 \text{ V}$

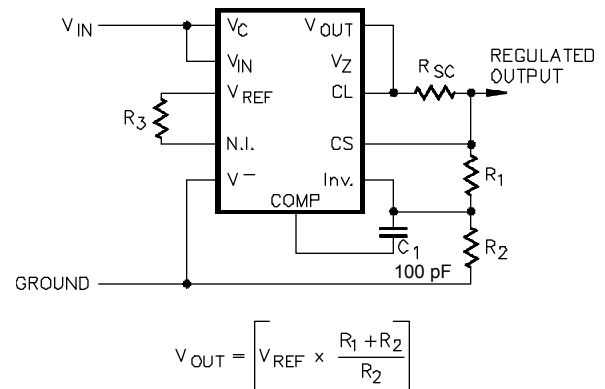

Figure 8 - Basic High Voltage Regulator $V_{OUT} = 7 \text{ V TO } 37 \text{ V}$

Application Information (Continued)

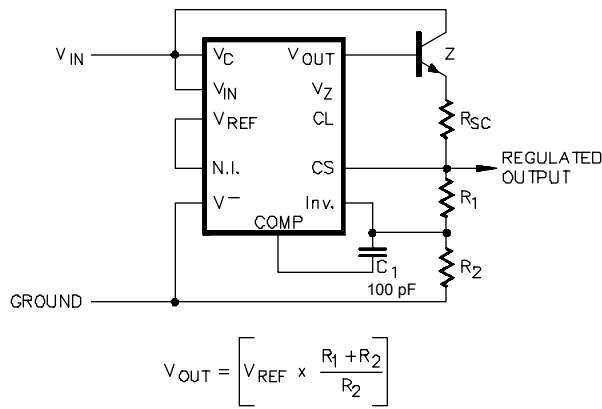

Figure 9 - High Current Regulator External NPN Transistor $I_L = 1.0$ A

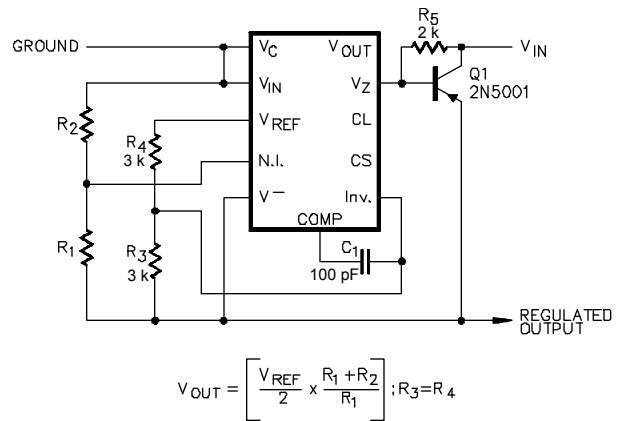

Figure 10 - Negative Voltage Regulator

Connection Diagrams and Ordering Information (See Notes Below)

Package	Part Number	Ambient Temperature Range	Connection Diagram
10-PIN CERAMIC FLAT PACK F - PACKAGE	SG723F-JAN	-55°C to 125°C	(Note 3)
14-PIN CERAMIC DIP J - PACKAGE	SG723J-JAN	-55°C to 125°C	
10-PIN METAL CAN T - PACKAGE	SG723T-JAN SG723T	-55°C to 125°C -55°C to 125°C	(Notes 3 & 4)

Note 1. Contact factory for JAN product availability.
 Note 2. All packages are viewed from the top. Lead finish is Sn63/Pb37 for RoHS compliant version contact factory.

Note 3. V_Z output is not available in T, F-packages.
 Note 4. Pin 5 is connected to case.

Package Outline Dimensions

Controlling dimensions are in inches, metric equivalents are shown for general information.

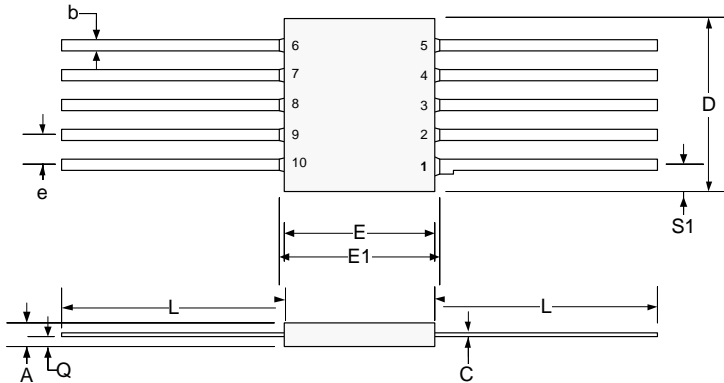

DIM	MILLIMETERS		INCHES	
	MIN	MAX	MIN	MAX
A	1.45	1.90	0.057	0.075
b	0.25	0.483	0.010	0.019
c	0.102	0.152	0.004	0.006
D	-	7.37	-	0.290
E	6.04	6.40	0.238	0.252
E1	-	6.91	-	0.272
e	1.27 BSC		0.050 BSC	
L	6.35	9.40	0.250	0.370
Q	0.51	1.02	0.020	0.040
S1	0.20	0.38	0.008	0.015

Note:

1. Lead No. 1 is identified by tab on lead or dot on cover.
2. Leads are within 0.13 mm (.0005") radius of the true position (TP) at maximum material condition.
3. Dimension "e" determines a zone within which all body and lead irregularities lie.
4. Dimensions are in mm, inches are for reference only.

Figure 11 · F 10-Pin Ceramic Flat-pack Package Outline Dimensions

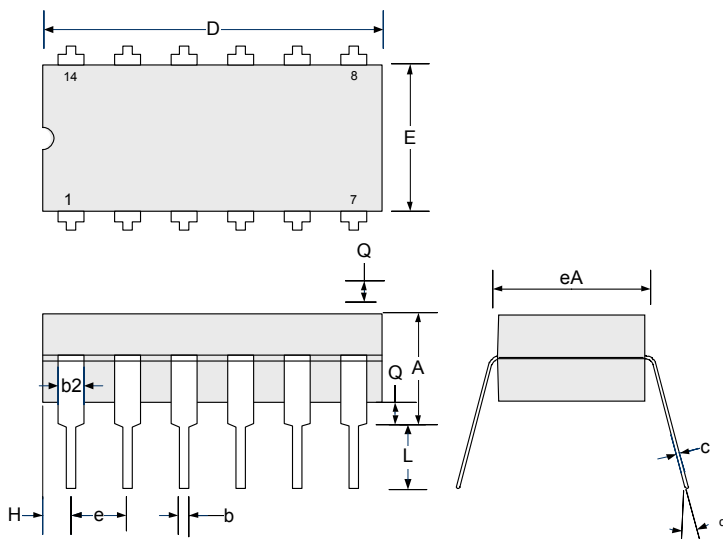

DIM	MILLIMETERS		INCHES	
	MIN	MAX	MIN	MAX
A	-	5.08	-	0.200
b	0.38	0.51	0.015	0.020
b2	1.04	1.65	0.045	0.065
c	0.20	0.38	0.008	0.015
D	19.30	19.94	0.760	0.785
E	5.59	7.11	0.220	0.280
e	2.54 BSC		0.100 BSC	
eA	7.37	7.87	0.290	0.310
H	0.63	1.78	0.025	0.070
L	3.18	5.08	0.125	0.200
α	-	15°	-	15°
Q	0.51	1.02	0.020	0.040

Note:

Dimensions do not include protrusions; these shall not exceed 0.155 mm (.006") on any side. Lead dimension shall not include solder coverage.

Figure 12 · J 14-Pin Ceramic Dip Package Dimensions

Package Outline Dimensions (Continued)

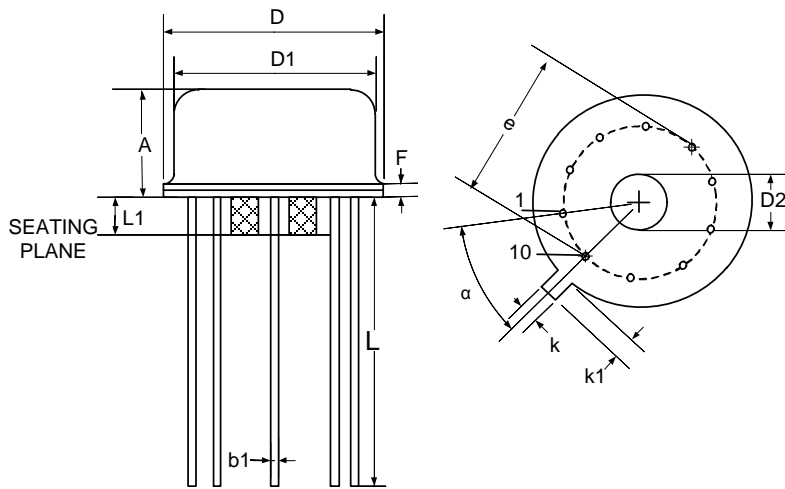

DIM	MILLIMETERS		INCHES	
	MIN	MAX	MIN	MAX
D	8.890	9.398	0.350	0.370
D1	8.00	8.51	0.315	0.335
A	4.191	4.699	0.165	0.185
b1	0.406	0.533	0.016	0.021
F	-	1.016	-	0.040
e	5.842 TYP		0.230 TYP	
k	0.711	0.864	0.028	0.034
k1	0.737	1.143	0.029	0.045
L	12.70	14.48	0.500	0.570
α	36° TYP		36° TYP	
D2	3.556	4.064	0.140	0.160
L1	0.254	1.016	0.010	0.040

Note:

Dimensions do not include protrusions; these shall not exceed 0.155 mm (.006") on any side. Lead dimension shall not include solder coverage.

Figure 13 · T 10-Pin Metal Can Package Dimensions



Microsemi Corporate Headquarters
One Enterprise, Aliso Viejo,
CA 92656 USA

Within the USA: +1 (800) 713-4113
Outside the USA: +1 (949) 380-6100
Sales: +1 (949) 380-6136
Fax: +1 (949) 215-4996

E-mail: sales.support@microsemi.com

© 2015 Microsemi Corporation. All rights reserved. Microsemi and the Microsemi logo are trademarks of Microsemi Corporation. All other trademarks and service marks are the property of their respective owners.

Microsemi Corporation (MSCC) offers a comprehensive portfolio of semiconductor and system solutions for communications, defense & security, aerospace and industrial markets. Products include high-performance and radiation-hardened analog mixed-signal integrated circuits, FPGAs, SoCs and ASICs; power management products; timing and synchronization devices and precise time solutions, setting the world's standard for time; voice processing devices; RF solutions; discrete components; security technologies and scalable anti-tamper products; Ethernet solutions; Power-over-Ethernet ICs and midspans; as well as custom design capabilities and services. Microsemi is headquartered in Aliso Viejo, Calif., and has approximately 3,600 employees globally. Learn more at www.microsemi.com.

Microsemi makes no warranty, representation, or guarantee regarding the information contained herein or the suitability of its products and services for any particular purpose, nor does Microsemi assume any liability whatsoever arising out of the application or use of any product or circuit. The products sold hereunder and any other products sold by Microsemi have been subject to limited testing and should not be used in conjunction with mission-critical equipment or applications. Any performance specifications are believed to be reliable but are not verified, and Buyer must conduct and complete all performance and other testing of the products, alone and together with, or installed in, any end-products. Buyer shall not rely on any data and performance specifications or parameters provided by Microsemi. It is the Buyer's responsibility to independently determine suitability of any products and to test and verify the same. The information provided by Microsemi hereunder is provided "as is, where is" and with all faults, and the entire risk associated with such information is entirely with the Buyer. Microsemi does not grant, explicitly or implicitly, to any party any patent rights, licenses, or any other IP rights, whether with regard to such information itself or anything described by such information. Information provided in this document is proprietary to Microsemi, and Microsemi reserves the right to make any changes to the information in this document or to any products and services at any time without notice.

Looking for pricing, stock, or lifecycle information?

Click below to explore more details on WIN SOURCE:

- ⊖ [View SG723J-JAN on WIN SOURCE](#)
- ⊖ [Microchip Technology](#) Information

Optimize Your Supply Chain with WIN SOURCE Solutions

- ✓ Global Sourcing Solution
- ✓ Obsolete Management
- ✓ Cost Control Management
- ✓ Shortage Management
- ✓ Alternative Solution
- ✓ Excess Inventory Management