



**THE DATASHEET OF
BD8924G-GTR**



Boost DC/DC Converter IC for TV tuner

BD8924G

General Description

Boost DCDC converter IC for TV tuner output 31V from 5V input voltage. It is possible to contribute to no adjustment and miniaturization of the set.

Features

- Over Current Protection.
- Small Package.
- Built-in UVLO(Under voltage Lockout).
- STB.
- Personal Medical Products.

Applications

- TV tuner(Analog · Digital).
- TV.
- Blue-ray Disc.
- STB.
- Personal Medical Products

Key Specifications

- Input Voltage Range: 4.5V to 5.5V
- Output Voltage: 31V
- Output Current: 4mA(Max)
- Switching Frequency: 400kHz(Typ)
- Operating Temperature Range: -30°C to +85°C

Package

SSOP5

W(Typ) x D(Typ) x H(Max)

2.80mm x 2.90mm x 1.25mm

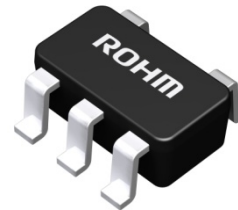

Typical Application Circuit

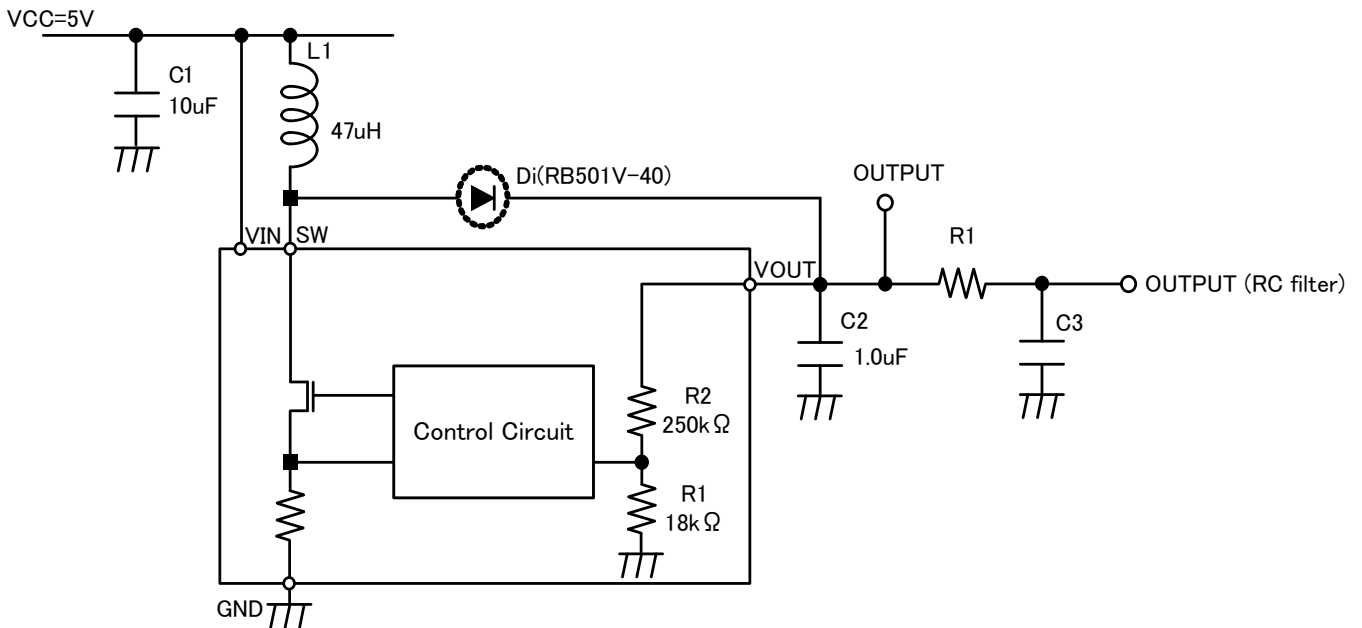

Contents

General Description	1
Features.....	1
Applications	1
Key Specifications	1
Typical Application Circuit	1
Contents	2
Pin Configuration(s)	3
Pin Description(s)	3
Input-Output Equivalent Circuit	3
Block Diagram(s)	4
Description of Block(s)	4
Absolute Maximum Ratings (Ta = 25°C)	5
Recommended Operating Conditions	5
Electrical Characteristics(Unless otherwise specified Ta=25°C, VIN=5V)	5
Typical Performance Curves	6
Figure 1. VIN vs ICC Figure 2. VIN vs Frequency	6
Figure 3. IOUT vs Efficiency Figure4. IOUT vs VOUT	6
Application Example1	8
Selection1 of Components Externally Connected	8
Application Example2	9
Selection2 of Components Externally Connected	9
Power Dissipation	10
About board layout.....	10
Operational Notes	11
Ordering Information	13
Marking Diagrams.....	13
Physical Dimension, Tape and Reel Information.....	14
Revision History	15

Pin Configuration(s)

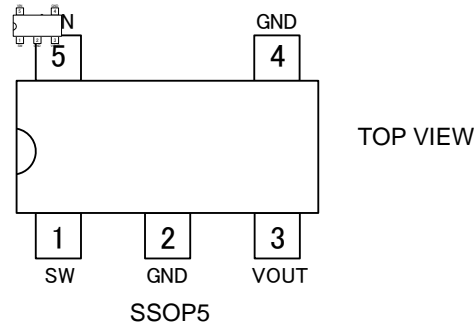

Pin Description(s)

Symbol	Pin No.	Function	Terminal circuit
SW	1	Inductor connection terminal	B
GND	2	GND	C
VOUT	3	Boost voltage output	A
GND	4	GND	C
VIN	5	Power supply input	D

Input-Output Equivalent Circuit

I/O equivalent circuit diagram is as follows.

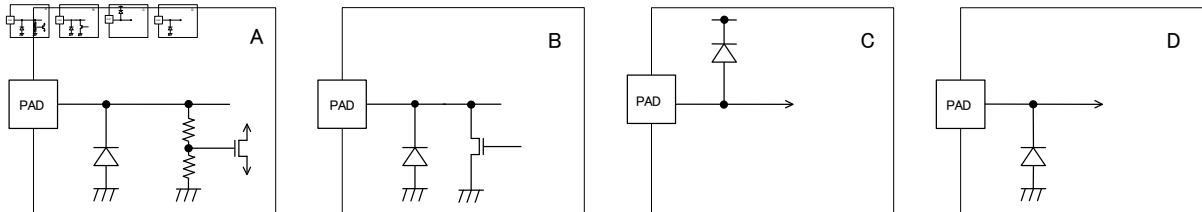

Block Diagram(s)

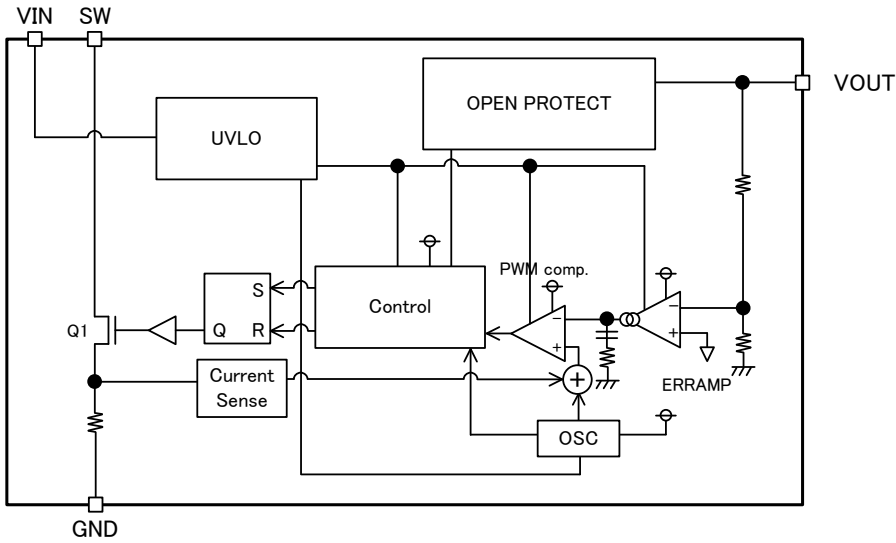

Description of Block(s)

- 1) Under voltage Lockout (UVLO)
 DCDC converter stops the boost action when power-supply voltage drops to detect voltage.
 UVLO release automatically when power-supply voltage rise, Release voltage is 3.2V to 4.2V.
- 2) Over Current Protection
 Over current protection circuit work when over current run to Q1.
- 3) Open Protect
 Q1 is OFF and prevent over current when VOUT terminal is Open.

Absolute Maximum Ratings (Ta = 25°C)

Parameter	Symbol	Ratings	Unit	Condition
Maximum applied voltage 1	Vmax1	7	V	It applies to VIN terminal
Maximum applied voltage 2	Vmax2	36	mW	It applies to SW, VOUT terminals
Power dissipation	Pd	674.9 (*1)	mW	At single unit
Operating temperature range	Topr	-30 ~ +85	°C	
Storage temperature range	Tstr	-55 ~ +150	°C	

*1 Pd derated at 5.4mW/°C for temperature above Ta=25°C, mounted on 70mm × 70mm × 1.6mm glass-epoxy PCB.

Recommended Operating Conditions

Parameter	Symbol	Ratings	Unit	Condition
Operation power supply voltage	VCC	4.5~5.5	V	VIN terminal voltage

Electrical Characteristics(Unless otherwise specified Ta=25°C, VIN=5V)

Parameter	Symbol	Min.	Typ.	Max.	Unit	Condition
Circuit current 1	ICC1	-	1.0	2.0	mA	Vout=35V force
Oscillation frequency	fsw	250	400	600	kHz	
Maximum output current1	Iomax1	2.0	-	-	mA	L1=47uH, C2=1uF
Maximum output current2	Iomax2	4.0	-	-	mA	L1=68uH, C2=1uF, C4 ≥ 15uF
Output voltage range	Vomax	30.0	31.0	32.0	V	Io=0mA
Oscillation beginning power-supply voltage	Vst	4.2	-	-	V	VIN Terminal Voltage The oscillation is confirmed with SW pin.
Efficiency	Eff	-	58.4	-	%	L=47uH, Io=2mA
ON Resistance	Ron	-	3.2	-	Ω	SW = 100mA force
Over Current Limiter Value	Clim	-	270	-	mA	
Load Regulation	LoadR	-	100	-	mV	0mA to 2mA
Line Regulation	LineR	-	50	-	mV	4.5V to 5.5V

Typical Performance Curves

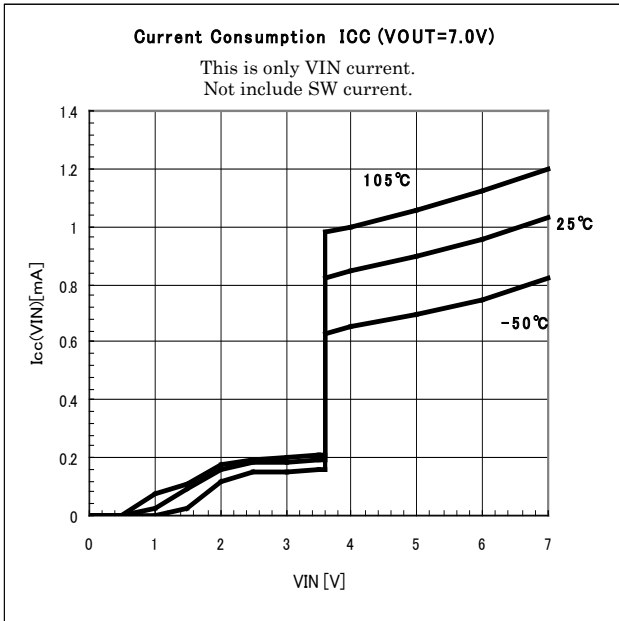

Figure 1. VIN vs ICC

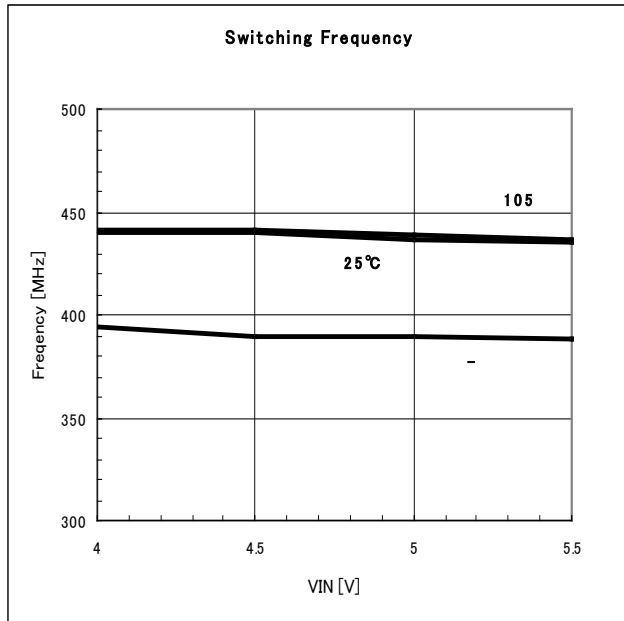

Figure 2. VIN vs Frequency

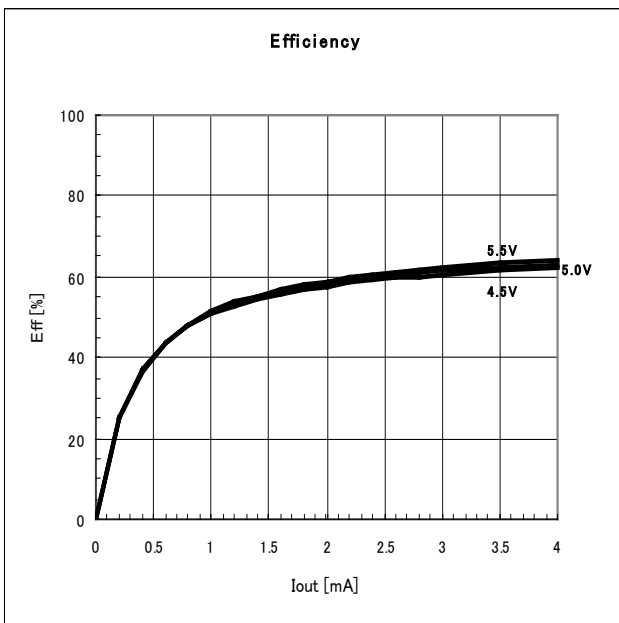

Figure 3. IOUT vs Efficiency

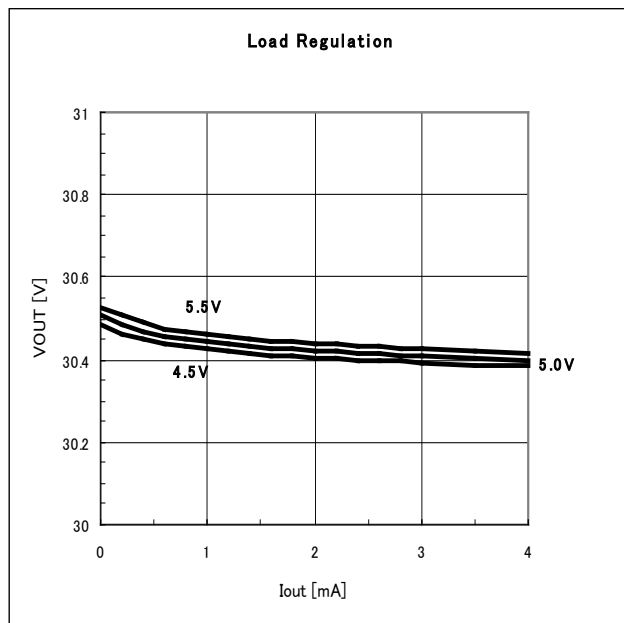

Figure 4. IOUT vs VOUT

Typical Performance Curves – continued

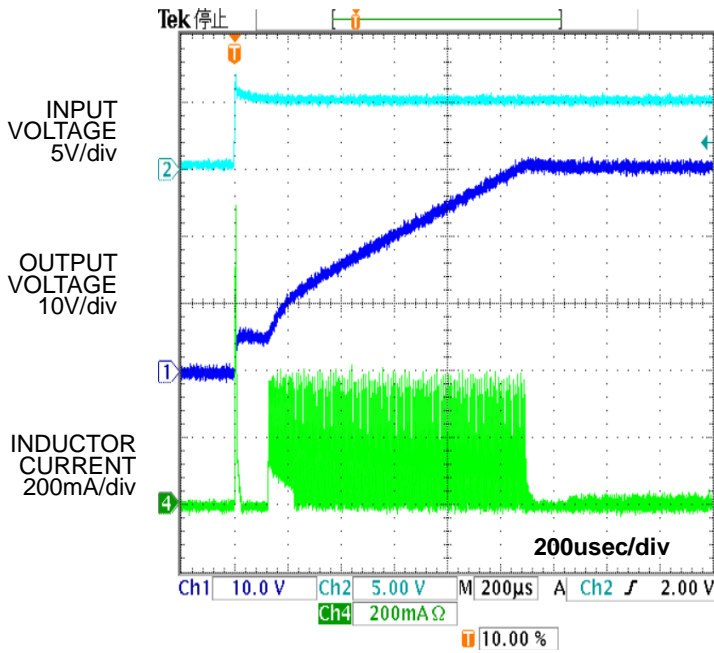

Fig5. EXITING SHUTDOWN (Condition: Vin=5V, VOUT=31V, Iload=0mA)

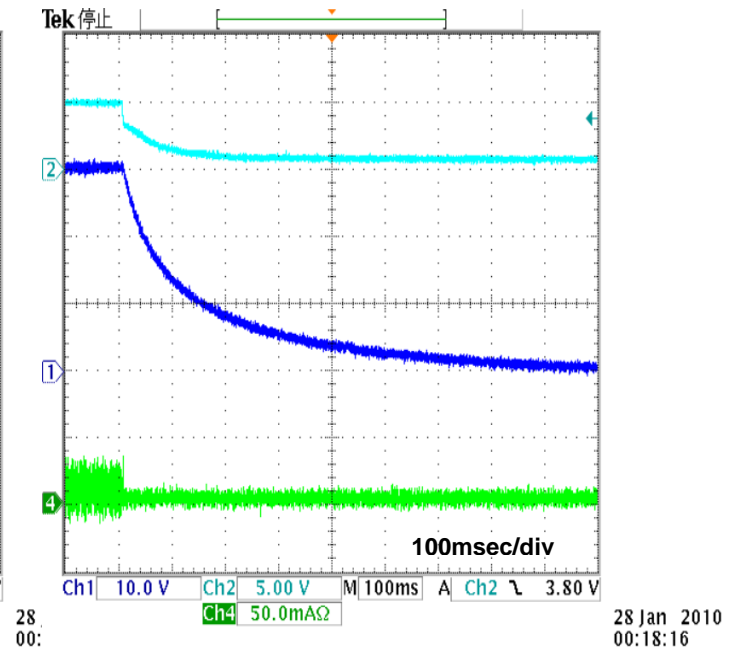

Fig6. ENTERING SHUTDOWN (Condition: Vin=5V, VOUT=31V, Iload=0mA)

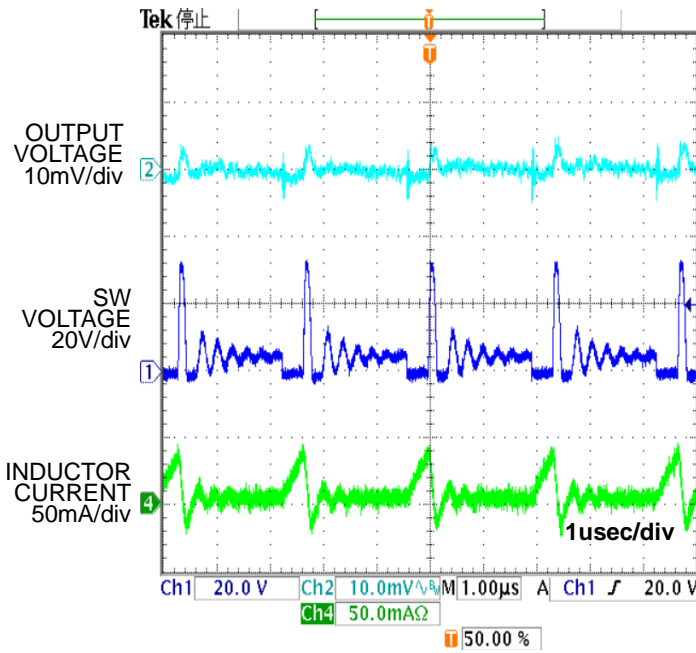

Fig7. LIGHT-ROAD SWITCHING WAVEFORM (Condition: Vin=5V, VOUT=31V, Iload=0mA)

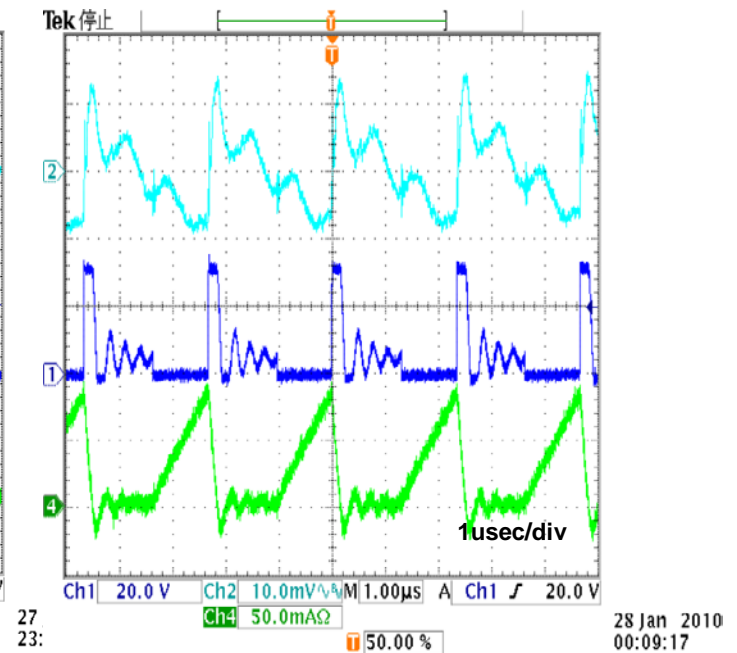
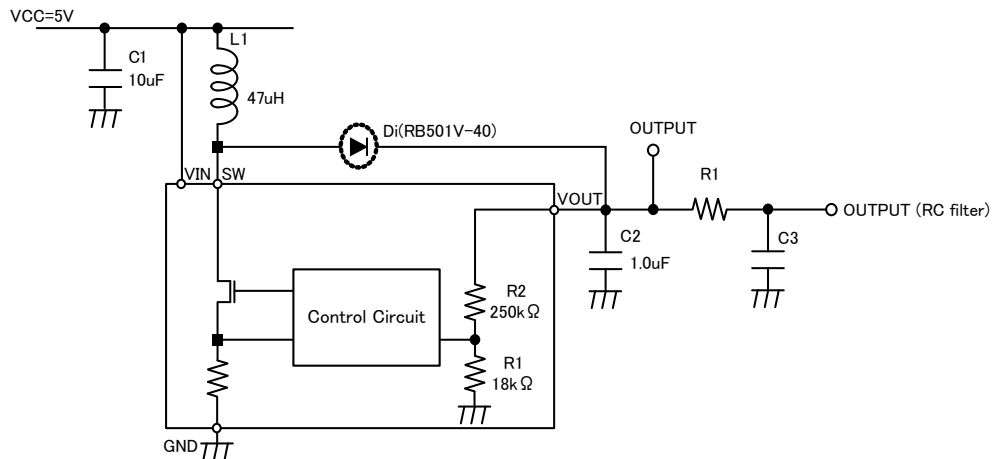

Fig8. ILOAD SWITCHING WAVEFORM WITHOUT RC FILTER (Condition: Vin=5V, VOUT=31V, Iload=2mA)

Application Example1In the case of $I_{omax} \leq 2mA$

< Recommend Circuit >

**Selection1 of Components Externally Connected**

Recommend RC filter when TV reception is bad with noise.

Parts No.	Name	Value	Use
L1	Inductance	47uH	For Boost
C1	Ceramic Capacitor	10uF~	Input decoupling
C2	Ceramic Capacitor	1uF~	Output decoupling
C3	Ceramic Capacitor	-	LPF
R1	Resistance	-	LPF

< About external parts >

(1) Input decoupling capacitor (C1)

Please connect the ceramic capacitor of 10uF or more nearest of LSI for low the impedance of VIN (power supply terminal). The capacity value should be made big according to the state of the output noise and the substrate.

(2) About Inductor (L1)

The inductor must use 47uH one. The characteristic that the direct current resistance is small, and the big one of the current rating is excellent is obtained about the selection of the inductor. It decides about the current rating of the inductor depending on the output voltage and the current that is necessary.

Moreover, the current of up to 270mA flows to the inductor when the inductor is in saturated region though a current limiter is built into BD8924G. Please inquire details about current rush of the inductor manufacturer.

(3) Output capacitor (C2)

Please use the ceramic capacitor of 1uF or more for an output smooth ripple. The voltage of 32V or more add to this capacitor. Please it joins and notices the resisting pressure and considers it is possible to pull out capacity by the temperature characteristic and the direct current bias characteristic about the capacitor. Especially, please note that the change in the direct current bias characteristic is large about the capacitor with small size of the case.

Please arrange this capacitor in nearest LSI as well as C1.

(4) LPF

Please compose LPF of R3 and C3, and cut the noise. (Especially needs in analog tuner.)

Application Example2In the case of $2\text{mA} < I_{\text{omax}} \leq 4\text{mA}$

< Recommend Circuit >

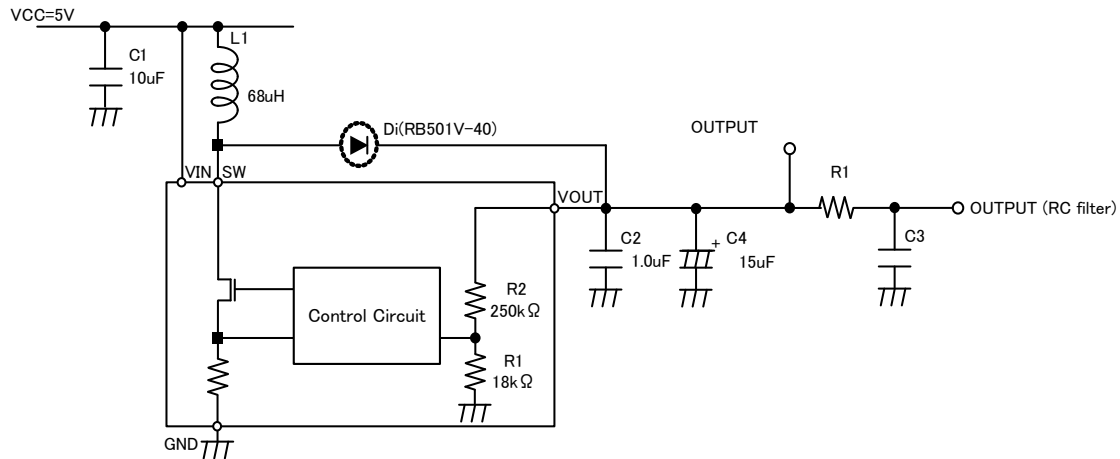
**Selection2 of Components Externally Connected**

Recommend RC filter when TV reception is bad with noise.

Parts No.	Name	Value	Use
L1	Inductance	68uH	For Boost
C1	Ceramic Capacitor	10uF~	Input decoupling
C2	Ceramic Capacitor	1uF~	Output decoupling
C3	Ceramic Capacitor	-	LPF
C4	Aluminum Electrolytic Capacitor	15uF~	Output decoupling
R1	Resistance	-	LPF

< About external parts >

(1) Input decoupling capacitor (C1)

Please connect the ceramic capacitor of 10uF or more nearest of LSI for low the impedance of VIN (power supply terminal). The capacity value should be made big according to the state of the output noise and the substrate.

(2) About Inductor (L1)

The inductor must use 68uH one. The characteristic that the direct current resistance is small, and the big one of the current rating is excellent is obtained about the selection of the inductor. It decides about the current rating of the inductor depending on the output voltage and the current that is necessary.

Moreover, the current of up to 270mA flows to the inductor when the inductor is in saturated region though a current limiter is built into BD8924G. Please inquire details about current rush of the inductor manufacturer.

(3) Output capacitor (C2 and C4)

Please use the ceramic capacitor of 1uF or more and Aluminum Electrolytic Capacitor of 15uF or more for an output smooth ripple. The voltage of 32V or more add to these capacitors. Please it joins and notices the resisting pressure and considers it is possible to pull out capacity by the temperature characteristic and the direct current bias characteristic about the capacitor. Especially, please note that the change in the direct current bias characteristic is large about the capacitor with small size of the case.

Please arrange these capacitors in nearest LSI as well as C1.

(4) LPF

Please compose LPF of R3 and C3, and cut the noise. (Especially needs in analog tuner.)

Power Dissipation

In the heat design, please operate it in the following condition.
 (Please consider the margin etc. because the following temperature is a guarantee temperature.)

1. Surrounding temperature T_a must be 85°C or less.
2. Loss of IC must be permissible loss P_d or less.

The allowable dissipation (P_d) characteristics are described below.

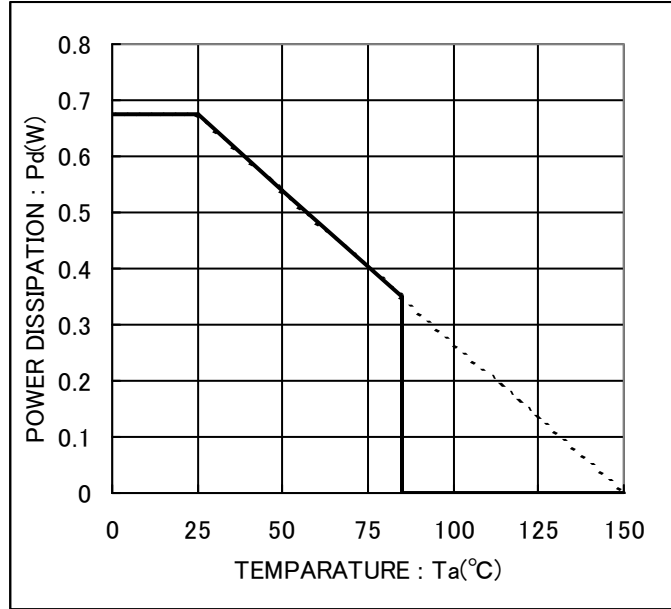

About board layout

BD8924G is switching DCDC converter, so characteristics of noise and etc changing by board layout. Please note the following respect besides a general board layout matter when you make PCB.

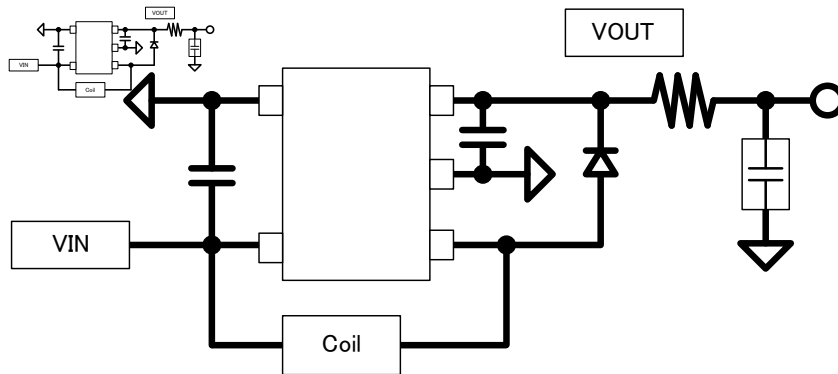

Operational Notes

1. Reverse Connection of Power Supply

Connecting the power supply in reverse polarity can damage the IC. Take precautions against reverse polarity when connecting the power supply, such as mounting an external diode between the power supply and the IC's power supply pins.

2. Power Supply Lines

Design the PCB layout pattern to provide low impedance supply lines. Furthermore, connect a capacitor to ground at all power supply pins. Consider the effect of temperature and aging on the capacitance value when using electrolytic capacitors.

3. Ground Voltage

Ensure that no pins are at a voltage below that of the ground pin at any time, even during transient condition.

4. Ground Wiring Pattern

When using both small-signal and large-current ground traces, the two ground traces should be routed separately but connected to a single ground at the reference point of the application board to avoid fluctuations in the small-signal ground caused by large currents. Also ensure that the ground traces of external components do not cause variations on the ground voltage. The ground lines must be as short and thick as possible to reduce line impedance.

5. Thermal Consideration

Should by any chance the power dissipation rating be exceeded the rise in temperature of the chip may result in deterioration of the properties of the chip. In case of exceeding this absolute maximum rating, increase the board size and copper area to prevent exceeding the Pd rating.

6. Recommended Operating Conditions

These conditions represent a range within which the expected characteristics of the IC can be approximately obtained. The electrical characteristics are guaranteed under the conditions of each parameter.

7. Inrush Current

When power is first supplied to the IC, it is possible that the internal logic may be unstable and inrush current may flow instantaneously due to the internal powering sequence and delays, especially if the IC has more than one power supply. Therefore, give special consideration to power coupling capacitance, power wiring, width of ground wiring, and routing of connections.

8. Operation Under Strong Electromagnetic Field

Operating the IC in the presence of a strong electromagnetic field may cause the IC to malfunction.

9. Testing on Application Boards

When testing the IC on an application board, connecting a capacitor directly to a low-impedance output pin may subject the IC to stress. Always discharge capacitors completely after each process or step. The IC's power supply should always be turned off completely before connecting or removing it from the test setup during the inspection process. To prevent damage from static discharge, ground the IC during assembly and use similar precautions during transport and storage.

Operational Notes – continued

10. Inter-pin Short and Mounting Errors

Ensure that the direction and position are correct when mounting the IC on the PCB. Incorrect mounting may result in damaging the IC. Avoid nearby pins being shorted to each other especially to ground, power supply and output pin. Inter-pin shorts could be due to many reasons such as metal particles, water droplets (in very humid environment) and unintentional solder bridge deposited in between pins during assembly to name a few.

11. Unused Input Pins

Input pins of an IC are often connected to the gate of a MOS transistor. The gate has extremely high impedance and extremely low capacitance. If left unconnected, the electric field from the outside can easily charge it. The small charge acquired in this way is enough to produce a significant effect on the conduction through the transistor and cause unexpected operation of the IC. So unless otherwise specified, unused input pins should be connected to the power supply or ground line.

12. Regarding the Input Pin of the IC

This monolithic IC contains P+ isolation and P substrate layers between adjacent elements in order to keep them isolated. P-N junctions are formed at the intersection of the P layers with the N layers of other elements, creating a parasitic diode or transistor. For example (refer to figure below):

When $GND > Pin A$ and $GND > Pin B$, the P-N junction operates as a parasitic diode.

When $GND > Pin B$, the P-N junction operates as a parasitic transistor.

Parasitic diodes inevitably occur in the structure of the IC. The operation of parasitic diodes can result in mutual interference among circuits, operational faults, or physical damage. Therefore, conditions that cause these diodes to operate, such as applying a voltage lower than the GND voltage to an input pin (and thus to the P substrate) should be avoided.

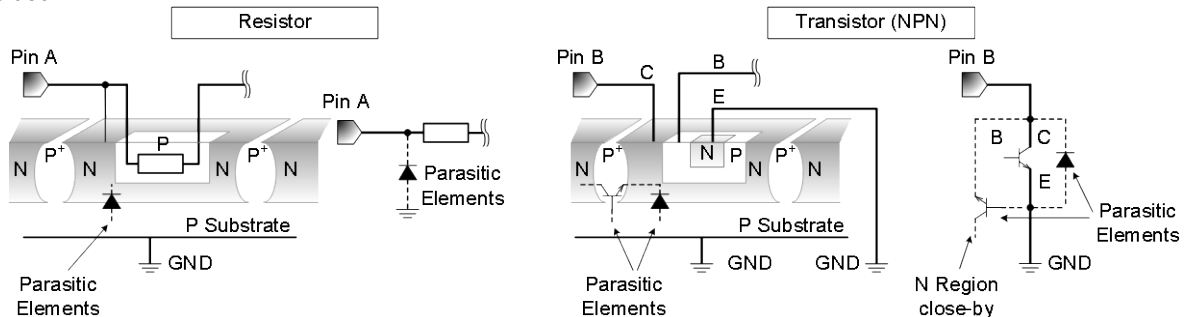

Figure xx. Example of monolithic IC structure

13. Ceramic Capacitor

When using a ceramic capacitor, determine the dielectric constant considering the change of capacitance with temperature and the decrease in nominal capacitance due to DC bias and others.

14. Area of Safe Operation (ASO)

Operate the IC such that the output voltage, output current, and power dissipation are all within the Area of Safe Operation (ASO).

15. Thermal Shutdown Circuit(TSD)

This IC has a built-in thermal shutdown circuit that prevents heat damage to the IC. Normal operation should always be within the IC's power dissipation rating. If however the rating is exceeded for a continued period, the junction temperature (T_j) will rise which will activate the TSD circuit that will turn OFF all output pins. When the T_j falls below the TSD threshold, the circuits are automatically restored to normal operation.

Note that the TSD circuit operates in a situation that exceeds the absolute maximum ratings and therefore, under no circumstances, should the TSD circuit be used in a set design or for any purpose other than protecting the IC from heat damage.

16. Over Current Protection Circuit (OCP)

This IC incorporates an integrated overcurrent protection circuit that is activated when the load is shorted. This protection circuit is effective in preventing damage due to sudden and unexpected incidents. However, the IC should not be used in applications characterized by continuous operation or transitioning of the protection circuit.

Ordering Information

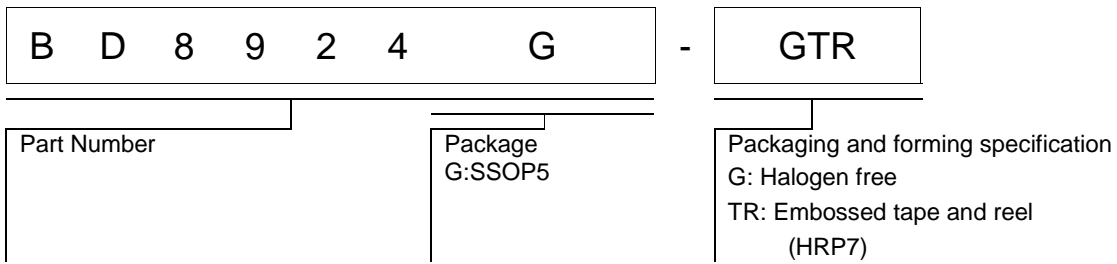

Marking Diagrams

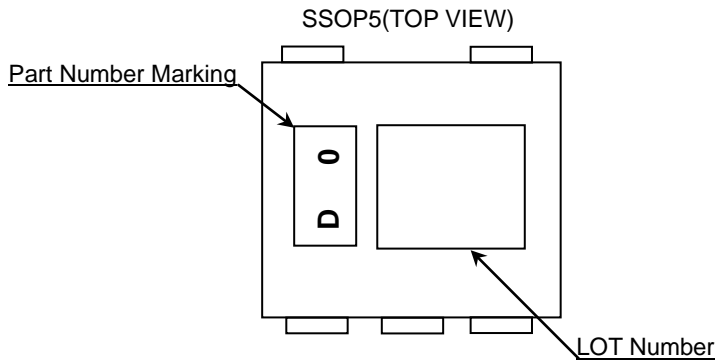

Part Number Marking	Package	Orderable Part Number
D0	SSOP5	BD8924G-GTR

Physical Dimension, Tape and Reel Information

Package Name	SSOP5
--------------	-------

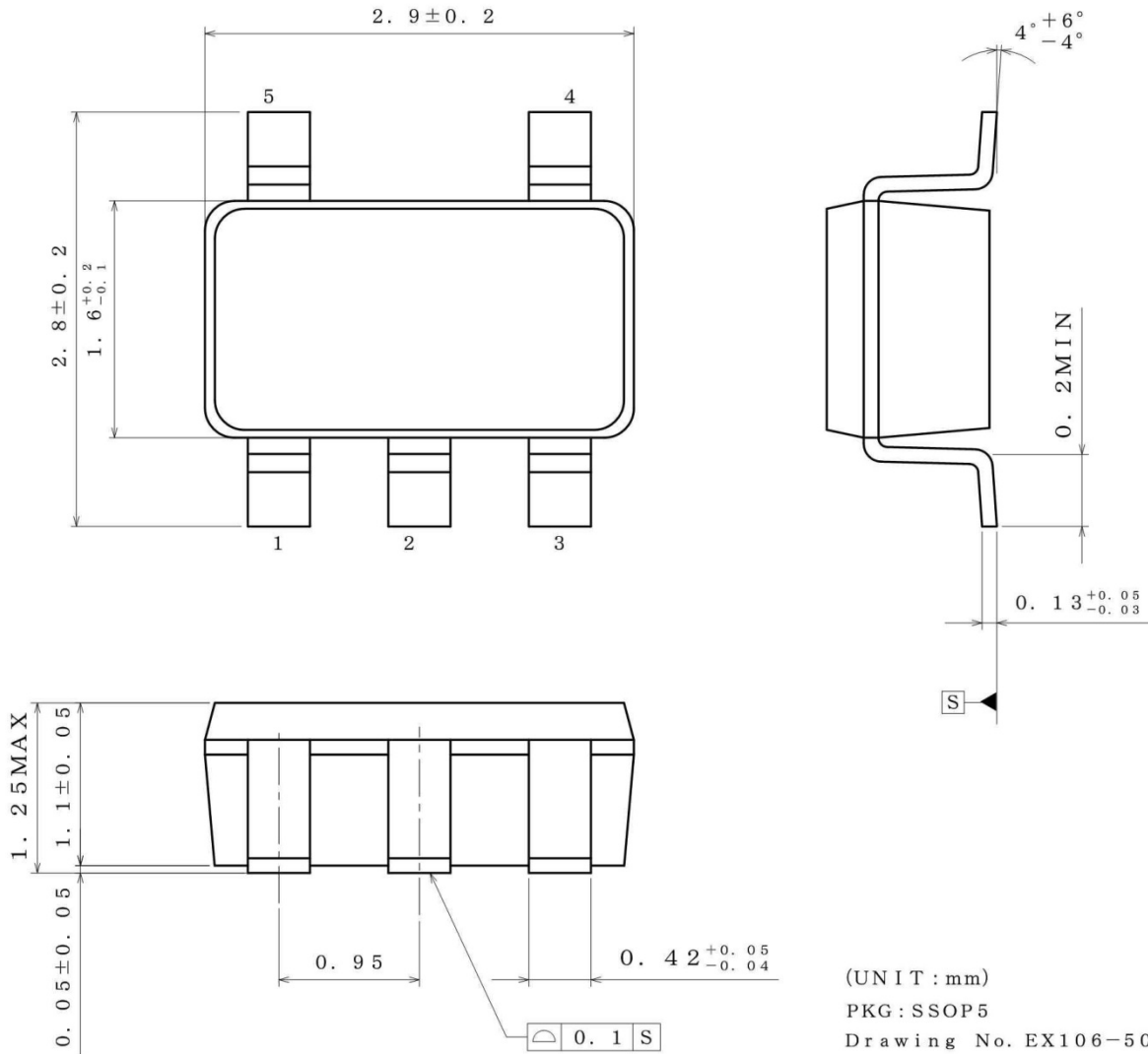

< Tape and Reel Information >

Tape	Embossed carrier tape
Quantity	3000pcs
Direction of feed	TR (The direction is the 1pin of product is at the upper right when you hold reel on the left hand and you pull out the tape on the right hand)

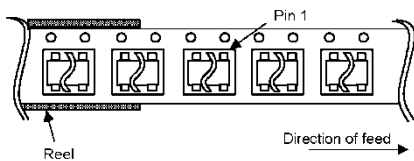

< Tape and Reel Information >

Tape	Embossed carrier tape
Quantity	3000pcs
Direction of feed	TL (The direction is the 1pin of product is at the lower left when you hold reel on the left hand and you pull out the tape on the right hand)

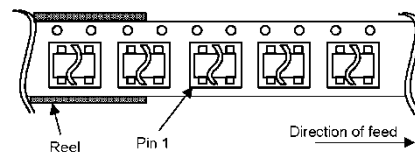

Revision History

Date	Revision	Changes
26.Jan.2015	001	New Release

Notice

Precaution on using ROHM Products

- Our Products are designed and manufactured for application in ordinary electronic equipments (such as AV equipment, OA equipment, telecommunication equipment, home electronic appliances, amusement equipment, etc.). If you intend to use our Products in devices requiring extremely high reliability (such as medical equipment ^(Note 1), transport equipment, traffic equipment, aircraft/spacecraft, nuclear power controllers, fuel controllers, car equipment including car accessories, safety devices, etc.) and whose malfunction or failure may cause loss of human life, bodily injury or serious damage to property ("Specific Applications"), please consult with the ROHM sales representative in advance. Unless otherwise agreed in writing by ROHM in advance, ROHM shall not be in any way responsible or liable for any damages, expenses or losses incurred by you or third parties arising from the use of any ROHM's Products for Specific Applications.

(Note1) Medical Equipment Classification of the Specific Applications

JAPAN	USA	EU	CHINA
CLASS III	CLASS III	CLASS II b	CLASS III
CLASS IV		CLASS III	

- ROHM designs and manufactures its Products subject to strict quality control system. However, semiconductor products can fail or malfunction at a certain rate. Please be sure to implement, at your own responsibilities, adequate safety measures including but not limited to fail-safe design against the physical injury, damage to any property, which a failure or malfunction of our Products may cause. The following are examples of safety measures:
 - Installation of protection circuits or other protective devices to improve system safety
 - Installation of redundant circuits to reduce the impact of single or multiple circuit failure
- Our Products are designed and manufactured for use under standard conditions and not under any special or extraordinary environments or conditions, as exemplified below. Accordingly, ROHM shall not be in any way responsible or liable for any damages, expenses or losses arising from the use of any ROHM's Products under any special or extraordinary environments or conditions. If you intend to use our Products under any special or extraordinary environments or conditions (as exemplified below), your independent verification and confirmation of product performance, reliability, etc. prior to use, must be necessary:
 - Use of our Products in any types of liquid, including water, oils, chemicals, and organic solvents
 - Use of our Products outdoors or in places where the Products are exposed to direct sunlight or dust
 - Use of our Products in places where the Products are exposed to sea wind or corrosive gases, including Cl₂, H₂S, NH₃, SO₂, and NO₂
 - Use of our Products in places where the Products are exposed to static electricity or electromagnetic waves
 - Use of our Products in proximity to heat-producing components, plastic cords, or other flammable items
 - Sealing or coating our Products with resin or other coating materials
 - Use of our Products without cleaning residue of flux (even if you use no-clean type fluxes, cleaning residue of flux is recommended); or Washing our Products by using water or water-soluble cleaning agents for cleaning residue after soldering
 - Use of the Products in places subject to dew condensation
- The Products are not subject to radiation-proof design.
- Please verify and confirm characteristics of the final or mounted products in using the Products.
- In particular, if a transient load (a large amount of load applied in a short period of time, such as pulse. is applied, confirmation of performance characteristics after on-board mounting is strongly recommended. Avoid applying power exceeding normal rated power; exceeding the power rating under steady-state loading condition may negatively affect product performance and reliability.
- De-rate Power Dissipation (Pd) depending on Ambient temperature (Ta). When used in sealed area, confirm the actual ambient temperature.
- Confirm that operation temperature is within the specified range described in the product specification.
- ROHM shall not be in any way responsible or liable for failure induced under deviant condition from what is defined in this document.

Precaution for Mounting / Circuit board design

- When a highly active halogenous (chlorine, bromine, etc.) flux is used, the residue of flux may negatively affect product performance and reliability.
- In principle, the reflow soldering method must be used on a surface-mount products, the flow soldering method must be used on a through hole mount products. If the flow soldering method is preferred on a surface-mount products, please consult with the ROHM representative in advance.

For details, please refer to ROHM Mounting specification

Precautions Regarding Application Examples and External Circuits

1. If change is made to the constant of an external circuit, please allow a sufficient margin considering variations of the characteristics of the Products and external components, including transient characteristics, as well as static characteristics.
2. You agree that application notes, reference designs, and associated data and information contained in this document are presented only as guidance for Products use. Therefore, in case you use such information, you are solely responsible for it and you must exercise your own independent verification and judgment in the use of such information contained in this document. ROHM shall not be in any way responsible or liable for any damages, expenses or losses incurred by you or third parties arising from the use of such information.

Precaution for Electrostatic

This Product is electrostatic sensitive product, which may be damaged due to electrostatic discharge. Please take proper caution in your manufacturing process and storage so that voltage exceeding the Products maximum rating will not be applied to Products. Please take special care under dry condition (e.g. Grounding of human body / equipment / solder iron, isolation from charged objects, setting of Ionizer, friction prevention and temperature / humidity control).

Precaution for Storage / Transportation

1. Product performance and soldered connections may deteriorate if the Products are stored in the places where:
 - [a] the Products are exposed to sea winds or corrosive gases, including Cl₂, H₂S, NH₃, SO₂, and NO₂
 - [b] the temperature or humidity exceeds those recommended by ROHM
 - [c] the Products are exposed to direct sunshine or condensation
 - [d] the Products are exposed to high Electrostatic
2. Even under ROHM recommended storage condition, solderability of products out of recommended storage time period may be degraded. It is strongly recommended to confirm solderability before using Products of which storage time is exceeding the recommended storage time period.
3. Store / transport cartons in the correct direction, which is indicated on a carton with a symbol. Otherwise bent leads may occur due to excessive stress applied when dropping of a carton.
4. Use Products within the specified time after opening a humidity barrier bag. Baking is required before using Products of which storage time is exceeding the recommended storage time period.

Precaution for Product Label

QR code printed on ROHM Products label is for ROHM's internal use only.

Precaution for Disposition

When disposing Products please dispose them properly using an authorized industry waste company.

Precaution for Foreign Exchange and Foreign Trade act

Since our Products might fall under controlled goods prescribed by the applicable foreign exchange and foreign trade act, please consult with ROHM representative in case of export.

Precaution Regarding Intellectual Property Rights

1. All information and data including but not limited to application example contained in this document is for reference only. ROHM does not warrant that foregoing information or data will not infringe any intellectual property rights or any other rights of any third party regarding such information or data. ROHM shall not be in any way responsible or liable for infringement of any intellectual property rights or other damages arising from use of such information or data.:
2. No license, expressly or implied, is granted hereby under any intellectual property rights or other rights of ROHM or any third parties with respect to the information contained in this document.

Other Precaution





1. This document may not be reprinted or reproduced, in whole or in part, without prior written consent of ROHM.
2. The Products may not be disassembled, converted, modified, reproduced or otherwise changed without prior written consent of ROHM.
3. In no event shall you use in any way whatsoever the Products and the related technical information contained in the Products or this document for any military purposes, including but not limited to, the development of mass-destruction weapons.
4. The proper names of companies or products described in this document are trademarks or registered trademarks of ROHM, its affiliated companies or third parties.

Looking for pricing, stock, or lifecycle information?

Click below to explore more details on WIN SOURCE:

-  [View BD8924G-GTR](#) on WIN SOURCE
-  [Rohm Semiconductor](#) Information

Optimize Your Supply Chain with WIN SOURCE Solutions

-  Global Sourcing Solution
-  Obsolete Management
-  Cost Control Management
-  Shortage Management
-  Alternative Solution
-  Excess Inventory Management