



200mA, Negative-Output, Low-Dropout Linear Regulator in SOT23

MAX1735

General Description

The MAX1735 negative-output, low-dropout linear regulator operates from a -2.5V to -6.5V input and delivers a guaranteed 200mA with a low 80mV dropout. The high-accuracy ($\pm 1\%$) output voltage is preset or can be adjusted from -1.25V to -5.5V with an external resistive voltage-divider.

An internal N-channel MOSFET allows for a low 85 μ A quiescent current virtually independent of the load, making this device ideal for battery-powered portable equipment, such as PDAs, mobile phones, cordless phones, and wireless data modems.

The device is available in several preset output voltage versions: -5.0V, -3.0V, and -2.5V. All versions offer a 1nA low-power shutdown mode, short-circuit protection, and thermal overload protection. The device is offered in a tiny 5-pin SOT23 package.

Applications

Disk Drives
Modems
Instrumentation Amplifiers
Notebook Computers
Mobile and Cordless Telephones
PCMCIA Cards
GaAsFET Bias
Mobile Wireless Data Modems
PDAs and Palmtop Computers

Features

- ◆ Guaranteed 200mA Output Current
- ◆ Low 80mV Dropout Voltage at 200mA
- ◆ Low 85 μ A Quiescent Supply Current
- ◆ Low 1nA Current Shutdown Mode
- ◆ Stable with 1 μ F C_{OUT}
- ◆ PSRR >60dB at 100Hz
- ◆ Thermal Overload Protection
- ◆ Short-Circuit Protection
- ◆ -5.0V, -3.0V, or -2.5V Output Voltage or Adjustable (-1.25V to -5.5V)
- ◆ Tiny SOT23-5 Package

Ordering Information

PART	TEMP RANGE	PIN-PACKAGE
MAX1735EUK50-T	-40°C to +85°C	5 SOT23-5
MAX1735EUK30-T	-40°C to +85°C	5 SOT23-5
MAX1735EUK25-T	-40°C to +85°C	5 SOT23-5

Output-Voltage Selector Guide

PART	PRESET OUTPUT VOLTAGE	SOT TOP MARK
MAX1735EUK50-T	-5.0V or adj	ADOZ
MAX1735EUK30-T	-3.0V or adj	ADOY
MAX1735EUK25-T	-2.5V or adj	ADOX

Typical Operating Circuit

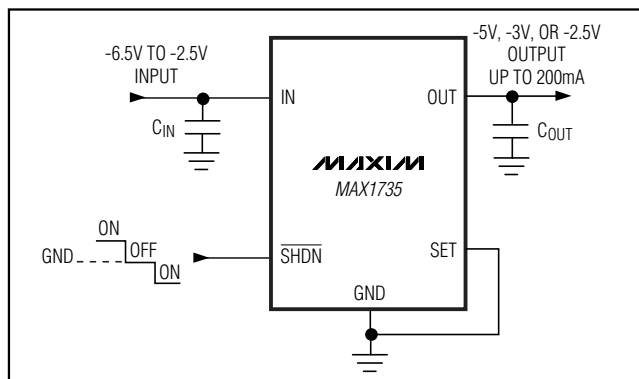

Pin Configuration

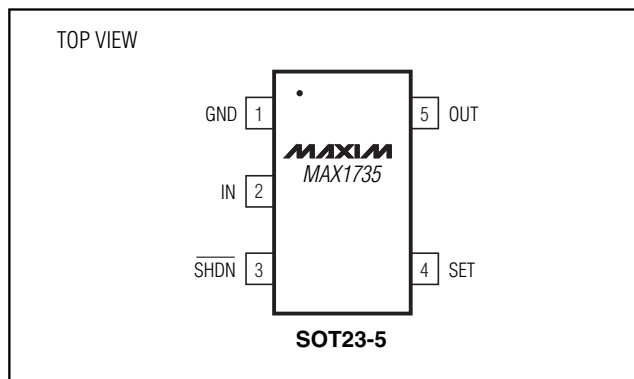

200mA, Negative-Output, Low-Dropout Linear Regulator in SOT23

ABSOLUTE MAXIMUM RATINGS

IN, SET to GND -7.0V to +0.3V
 SHDN to GND (VIN - 0.3)V to +7.0V
 OUT to GND (VIN - 0.3)V to +0.3V
 Output Short-Circuit Duration Indefinite
 Continuous Power Dissipation (TA = +70°C)
 5-Pin SOT23 (derate 7.1mW/°C above +70°C) 571mW

Operating Temperature Range -40°C to +85°C
 Junction Temperature +150°C
 Storage Temperature Range -65°C to +150°C
 Lead Temperature (soldering, 10s) +300°C

Stresses beyond those listed under "Absolute Maximum Ratings" may cause permanent damage to the device. These are stress ratings only, and functional operation of the device at these or any other conditions beyond those indicated in the operational sections of the specifications is not implied. Exposure to absolute maximum rating conditions for extended periods may affect device reliability.

ELECTRICAL CHARACTERISTICS

(Circuit of Figure 2, VIN = VOUT - 1V, VSHDN = VIN, TA = -40°C to +85°C, unless otherwise noted. Typical values are at TA = +25°C.) (Note 1)

PARAMETER	SYMBOL	CONDITIONS	MIN	TYP	MAX	UNITS
Input Voltage	VIN		-6.5		-2.5	V
Output Voltage Accuracy		TA = +25°C, IOUT = -100μA	-1		+1	%
		IOUT = -100μA, TA = 0°C to +85°C	-2		+2	
		ILOAD = -100μA to -200mA	-3		+2	
SET Regulation Set Point		Circuit of Figure 3, TA = +25°C, IOUT = -100μA	-1.2625	-1.25	-1.2375	V
		Circuit of Figure 3, IOUT = -100μA, TA = 0°C to +85°C	-1.275		-1.225	
		Circuit of Figure 3, ILOAD = -100μA to -200mA	-1.275		-1.2125	
Maximum Output Current	IOUT		-200			mA
Current Limit	ILIM	VOUT = 0	-1020	-515	-250	mA
Ground-Pin Current	IQ	IOUT = -100μA	-180	-85		μA
		IOUT = -200mA		-125		
Dropout Voltage (Note 2)		IOUT = -100mA		40		mV
		IOUT = -200mA		80	240	
Line Regulation		Circuit of Figure 3, VIN from -6.5V to -2.5V, VOUT = -1.25V	-0.15	0	+0.15	%/V
Load Regulation		IOUT from 0mA to -200mA		0.004		%/mA
Output Voltage Noise		10Hz to 1MHz, COUT = 1μF		160		μVRMS
Power-Supply Rejection Ratio	PSRR	f = 100Hz		60		dB
Shutdown Supply Current		VSHDN = 0	TA = +25°C	-1	-0.001	μA
			TA = +85°C		-1	
SHDN Input High Threshold (Note 3)		Positive voltage at SHDN			+1.6	V
		Negative voltage at SHDN	-1.6			
SHDN Input Low Threshold (Note 3)		Positive voltage at SHDN	+0.4			V
		Negative voltage at SHDN			-0.4	
Set Input Bias Current	ISET	VSET = -1.25V, TA = +25°C	-100	-15		nA
SHDN Input Bias Current		TA = +25°C	VSHDN = +6.5V		3.5	μA
			VSHDN = 0, -6.5V	-0.5		
Thermal Shutdown Junction Temperature		Hysteresis = 15°C (typ)		160		°C

Note 1: Limits are 100% production tested at TA = +25°C. Limits over operating temperature range are guaranteed by design.

Note 2: The dropout voltage is defined as VOUT - VIN, when VOUT is 100mV above the nominal value of VOUT.

Note 3: The SHDN logic input can be driven by either a positive voltage or a negative voltage. |VSHDN| < 0.4V puts the device in shutdown, while |VSHDN| > 1.6V enables the device.

200mA, Negative-Output, Low-Dropout Linear Regulator in SOT23

MAX1735

Typical Operating Characteristics

(Circuit of Figure 2, $V_{IN} = -4.0V$, $V_{OUT} = -3.0V$, $T_A = +25^\circ C$, unless otherwise specified.)

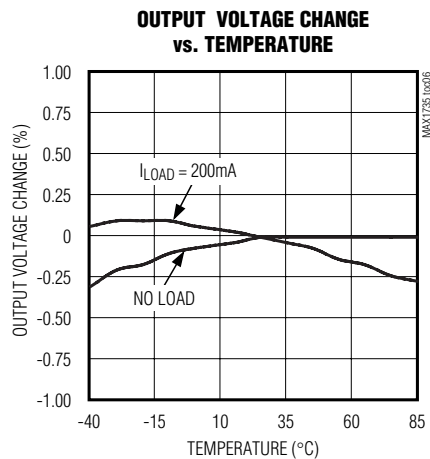
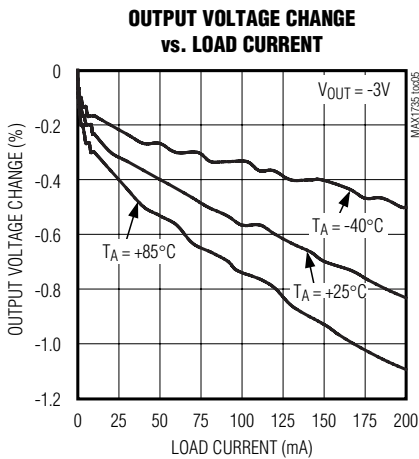
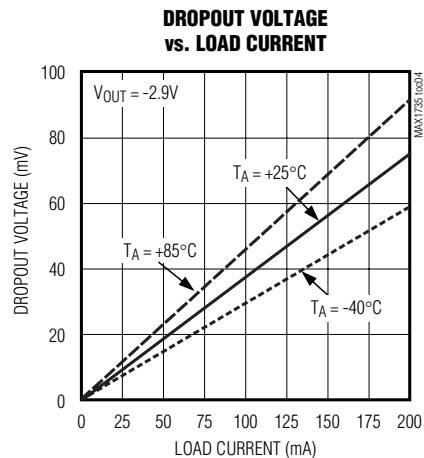
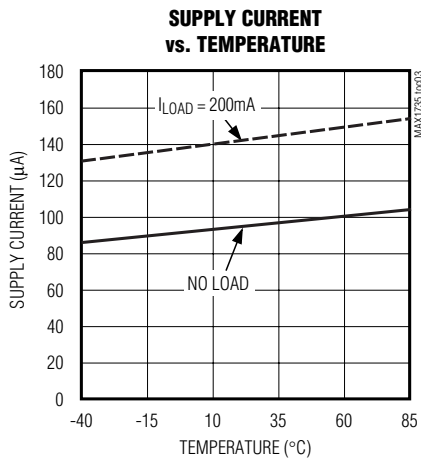
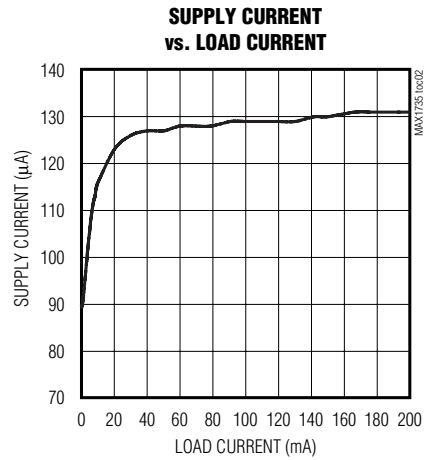
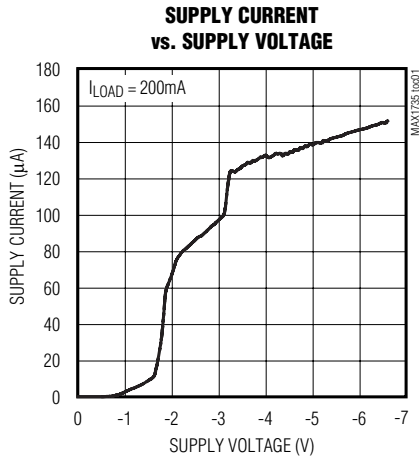

200mA, Negative-Output, Low-Dropout Linear Regulator in SOT23

Typical Operating Characteristics (continued)

(Circuit of Figure 2, $V_{IN} = -4.0V$, $V_{OUT} = -3.0V$, $T_A = +25^\circ C$, unless otherwise specified.)

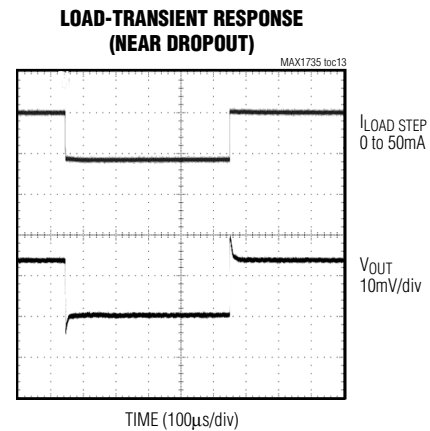
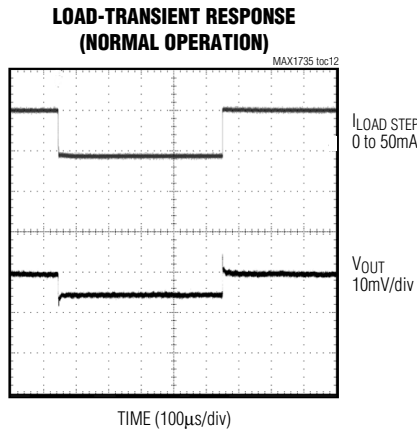
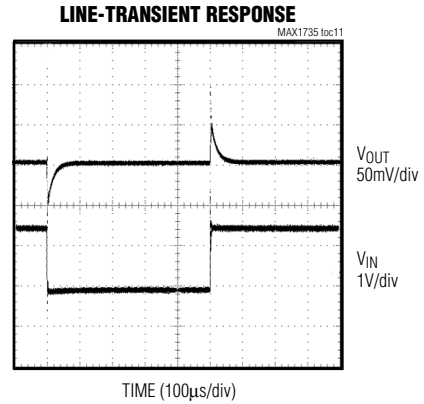
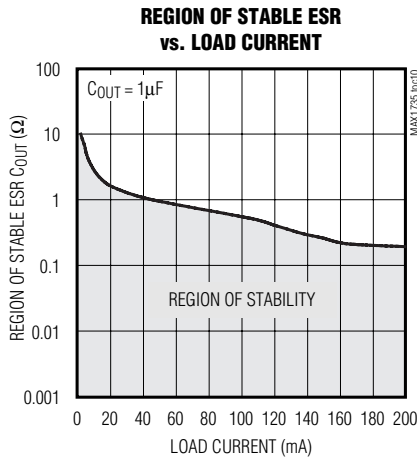
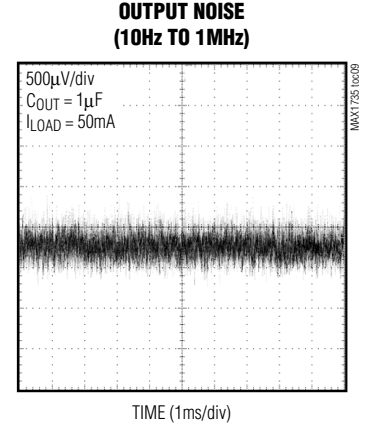
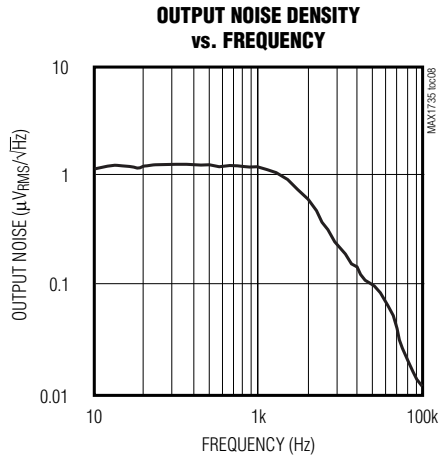
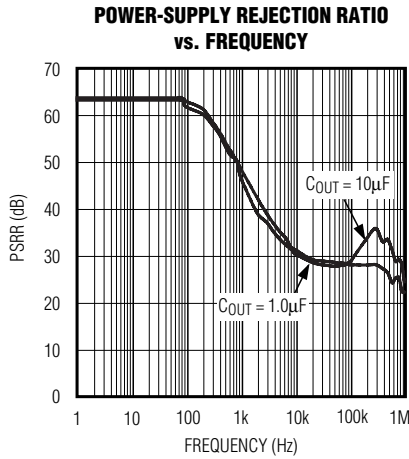

200mA, Negative-Output, Low-Dropout Linear Regulator in SOT23

MAX1735

Typical Operating Characteristics (continued)

(Circuit of Figure 2, $V_{IN} = -4.0V$, $V_{OUT} = -3.0V$, $T_A = +25^{\circ}C$, unless otherwise specified.)

**SHUTDOWN RESPONSE
(DRIVEN FROM A POSITIVE VOLTAGE)**

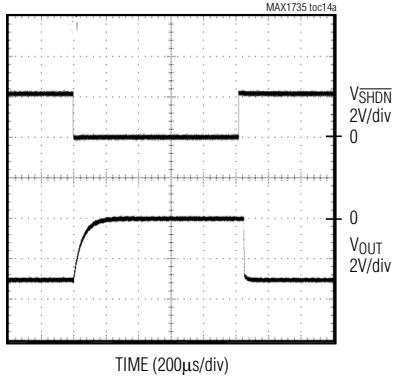

**SHUTDOWN RESPONSE
(DRIVEN BY A NEGATIVE VOLTAGE)**

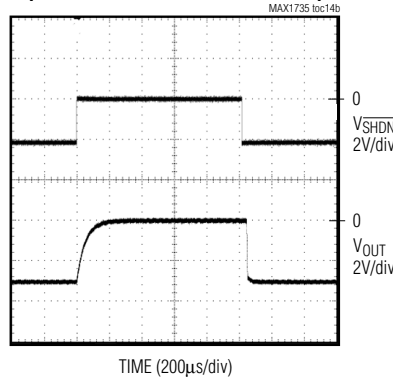

**SHUTDOWN-PIN BIAS CURRENT
vs. SHUTDOWN-PIN VOLTAGE**

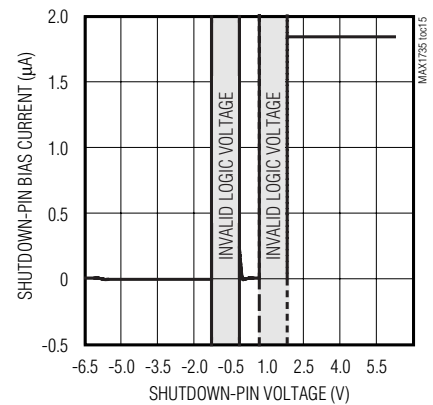

Pin Description

PIN	NAME	FUNCTION
1	GND	Ground
2	IN	Regulator Input. Supply voltage can range from -2.5V to -6.5V. Bypass with a 1µF capacitor to GND (see <i>Capacitor Selection and Regulator Stability</i>). This pin also functions as a heatsink. Solder to a large PC board pad or directly to the PC board power plane to maximize thermal dissipation.
3	$\overline{\text{SHDN}}$	Shutdown Input. Drive $\overline{\text{SHDN}}$ to GND to turn the regulator off, reducing the input current to less than 1nA. Drive $\overline{\text{SHDN}}$ above +1.6V or below -1.6V to enable the regulator. Connect $\overline{\text{SHDN}}$ to IN for always-on operation.
4	SET	Dual Mode™ Regulator Feedback Input. Connect SET to GND for the preset output voltage. Use a resistive voltage-divider from OUT to SET to set the output voltage between -1.25V and -5.5V. Regulation setpoint is -1.25V.
5	OUT	Regulator Output. OUT supplies up to 200mA in regulation. Bypass to GND with a 1µF ceramic capacitor.

Dual Mode is a trademark of Maxim Integrated Products, Inc.

200mA, Negative-Output, Low-Dropout Linear Regulator in SOT23

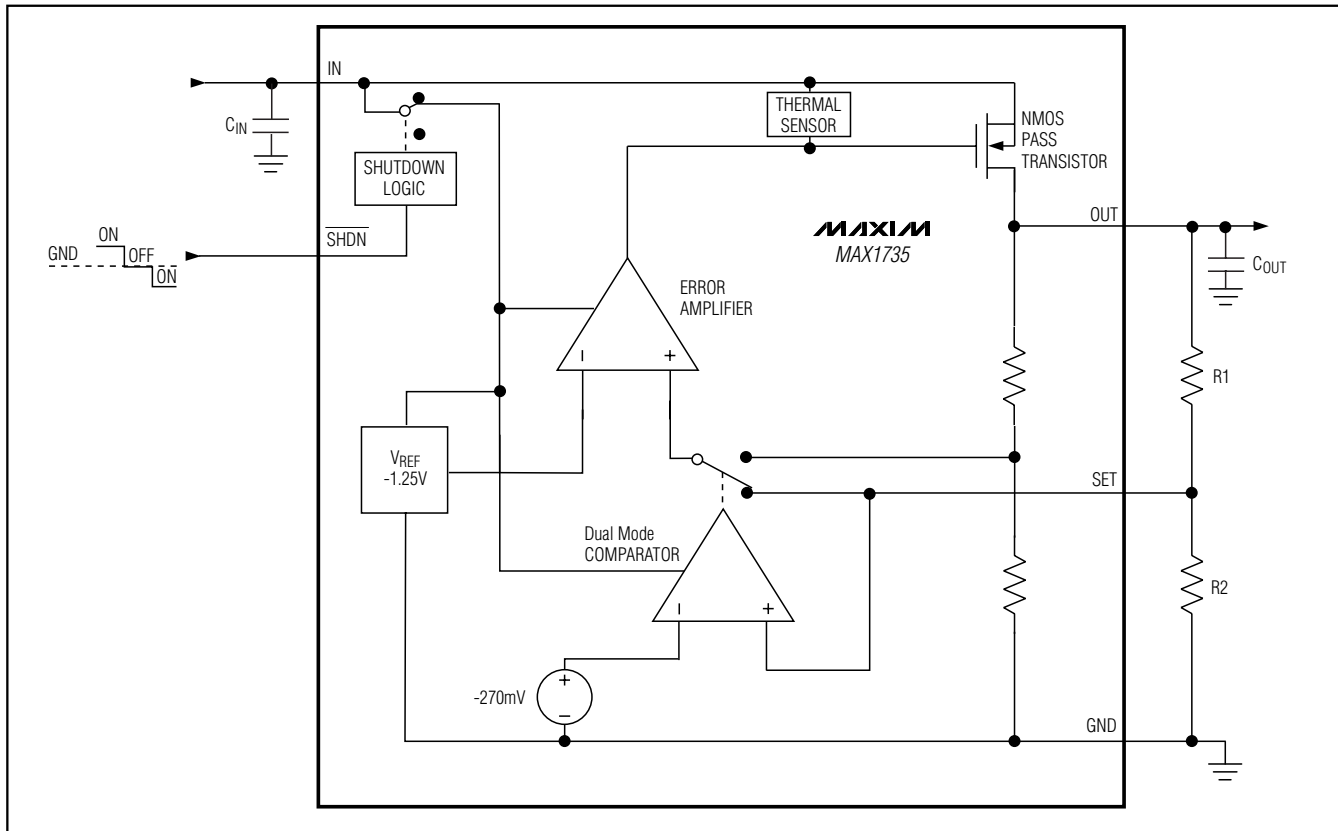

Figure 1. Functional Diagram

Detailed Description

The MAX1735 is a low-dropout negative linear voltage regulator. It features Dual Mode operation, allowing a fixed -5.0V, -3.0V, or -2.5V output voltage or an adjustable output from -1.25V to -5.5V. The regulator is guaranteed to supply 200mA of output current. It features 60dB power-supply rejection for noise-sensitive applications and a low 85 μ A operating current that optimizes it for battery-operated devices.

As Figure 1 illustrates, the device consists of an internal -1.25V reference, an error amplifier, an N-channel MOSFET, an internal precision-trimmed feedback voltage-divider, and a Dual Mode comparator.

The -1.25V reference is connected to the inverting input of the error amplifier. The error amplifier compares the reference voltage with the selected feedback voltage and amplifies the difference. The error amplifier drives the MOSFET to control the output voltage.

The feedback voltage for regulation is generated by either an internal or external resistive voltage-divider connected from OUT to SET. The internal Dual Mode

comparator selects the feedback path based on VSET. Connect SET to GND to use the internal feedback path, setting the output voltage to the preset value. If an external voltage-divider is used, see *Output Voltage Selection*.

Internal N-Channel MOSFET

The MAX1735 features an N-channel MOSFET pass transistor. Unlike similar designs using NPN bipolar pass transistors, N-channel MOSFETs require extremely low drive currents, reducing overall quiescent current. Also, NPN-based regulators consume still more base current in dropout conditions when the pass transistor saturates. The MAX1735 does not suffer from these problems, consuming only 125 μ A total current at full load and in dropout.

Output Voltage Selection

The MAX1735 features Dual Mode operation, allowing for a preset or adjustable output voltage. In preset voltage mode, the output of the MAX1735 is set to -5.0V, -3.0V, or -2.5V (see *Ordering Information*). Select this mode by connecting SET to GND (Figure 2).

200mA, Negative-Output, Low-Dropout Linear Regulator in SOT23

MAX1735

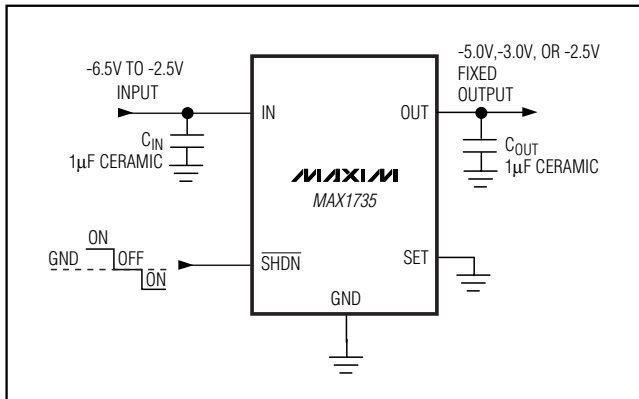

Figure 2. Typical Application Circuit with Preset Output Voltage

In adjustable mode, an output voltage between -5.5V and -1.25V is selected using two external resistors connected as a voltage-divider from OUT to SET (Figure 3). The output voltage is determined by the following equation:

$$V_{OUT} = V_{SET} \left[1 + \left(\frac{R1}{R2} \right) \right]$$

where $V_{SET} = V_{REFERENCE} = -1.25V$ when in regulation. Since the input bias current at SET is $<100nA$, use large resistance values for R1 and R2 to minimize power consumption in the feedback network. A typical value of 100kΩ for R2 is acceptable for most applications. Higher values consume less current at the expense of output voltage accuracy. The above equation solved for R1 is:

$$R1 = R2 \left[\left(\frac{V_{OUT}}{V_{SET}} \right) - 1 \right]$$

For preset output voltage mode, connect SET directly to GND.

Shutdown

In shutdown, the N-channel MOSFET, control circuitry, reference, and all internal circuits are turned off, reducing supply current to typically 1nA. \overline{SHDN} can be driven by either a positive or negative voltage. Drive \overline{SHDN} above +1.6V or below -1.6V to turn the regulator on. To turn the regulator off, drive \overline{SHDN} to GND. For always-on operation, connect \overline{SHDN} to IN. By including a positive threshold at \overline{SHDN} , it can be driven by a standard 5V TTL level without needing level-shifting circuitry.

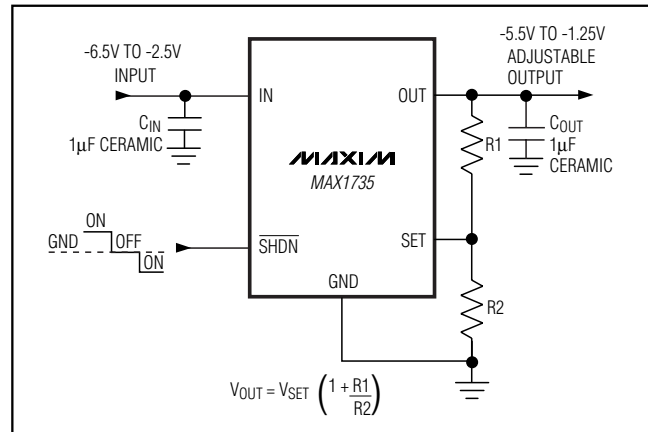

Figure 3. Typical Application Circuit with Adjustable Output Voltage

Current Limiting

The MAX1735 features a current limit that protects the regulator. Short-circuit output current is typically 515mA. The output will withstand a short to ground indefinitely; however, if the increased power dissipation heats the die to +160°C, the thermal overload protection will shut off the regulator, preventing damage to the IC.

Thermal Overload Protection

The thermal overload protection circuit protects the regulator against overheating due to prolonged overload conditions. When the die temperature exceeds +160°C, an on-chip thermal sensor disables the pass transistor, allowing the IC to cool. The thermal sensor reenables the pass MOSFET once the die temperature drops 15°C. A continuous short-circuit fault condition results in a cyclical enabling and disabling of the output.

Thermal overload protection is designed to safeguard the MAX1735 in the event of overload fault conditions. For normal operation, do not exceed the absolute maximum junction temperature rating of +150°C. Junction temperature is greater than ambient by an amount depending on package heat dissipation and the thermal resistance from the junction to ambient (θ_{JA}):

$$T_{JUNCTION} = T_{AMBIENT} + (\theta_{JA})(P_{DISSIPATION})$$

where

$$\theta_{JA} \text{ for the 5-pin SOT23 is about } 0.140^{\circ}\text{C/mW.}$$

200mA, Negative-Output, Low-Dropout Linear Regulator in SOT23

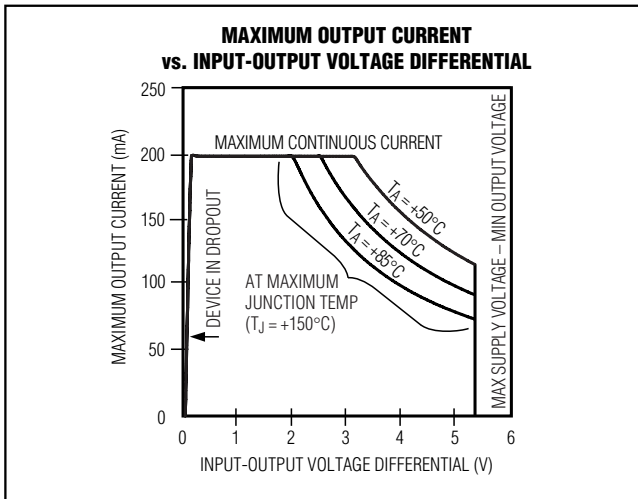

Figure 4. Output Current and In-Out Voltage Differential Operating Region Bounded by Available Power Dissipation at Selected Ambient Temperatures

Operating Region and Power Dissipation

Maximum power dissipation of the MAX1735 depends on the thermal resistance of the case and the circuit board, the temperature difference between the die junction and ambient air, and the rate of air flow (see also *Thermal Overload Protection*). The maximum power that can be dissipated by the device is:

$$P_{MAX} = \frac{T_{JMAX} - T_A}{\theta_{JC} + \theta_{CA}} = \frac{T_{JMAX} - T_A}{\theta_{JA}}$$

where the numerator expresses the temperature difference between the maximum allowed die junction (+150°C) and the surrounding air, θ_{JC} (junction to case) is the thermal resistance of the package, and θ_{CA} (case to ambient) is the thermal resistance from the package through the PC board, traces, and other material to the surrounding air. The former is a characteristic solely of the device in its package, and the latter is completely defined by PC board layout and airflow. It is important to note that the ability to dissipate power is as much a function of the PC board layout and air flow as the packaged part itself. Hence, a manufacturer can reliably provide a value for θ_{JC} , but *not* accurately provide a value for the total thermal resistance θ_{JA} . θ_{JA} is the sum of θ_{JC} and θ_{CA} , and the manufacturer can seldom reliably predict the thermal characteristics of the application circuit. Figure 4 shows the estimated allowable power dissipation for a MAX1735 mounted on a typical PC board at ambient temperatures of +50°C, +70°C, and +85°C.

Figure 4 shows the maximum continuous output current for a particular input-to-output voltage differential, for

selected ambient temperatures. The working principle is that the SOT23-5 package is small enough that in a typical application circuit at room temperature, the package cannot dissipate enough power to allow -6.5V to be regulated to -1.25V at -200mA output (more than 1200mW). As ambient temperature falls, the available power dissipation increases to allow for a greater operating region. The equation for the family of curves follows:

$$|I_{OUT}| = \frac{P_{MAX} - \frac{T_A - 70}{\theta_{JA}}}{|V_{OUT} - V_{IN}|}$$

where $|I_{OUT}|$ is in mA, $|V_{OUT} - V_{IN}|$ in V, P_{MAX} (571mW) is the absolute maximum rated power dissipation at +70°C for the SOT23-5, and θ_{JA} (0.140°C/mW) is the approximate junction-to-ambient thermal resistance of the SOT23-5 in a typical application.

A key to reducing θ_{CA} , thereby increasing thermal conductivity to the PC board, is to provide large PC board pads and traces for IN.

Applications Information

Capacitor Selection and Regulator Stability

Capacitors are required at the input and output of the MAX1735. Connect a 1 μ F or greater capacitor between IN and GND. This input capacitor serves only to lower the source impedance of the input supply in transient conditions; a smaller value can be used when the regulator is powered from a low-impedance source, such as another regulated supply or low-impedance batteries. For output voltages between -2.5V and -5.5V, connect a 1 μ F or greater capacitor between OUT and GND. For voltages between -1.25V and -2.5V, use a 2.2 μ F or greater output capacitor. The maximum value of the output capacitor to guarantee stability is 10 μ F.

The output capacitor's value and equivalent series resistance (ESR) affect stability and output noise. To ensure stability and optimum transient response, output capacitor ESR should be 0.1 Ω or less for output voltages from -1.25V to -2.45V and 0.2 Ω or less for output voltages between -2.5V and -5.5V. Inexpensive surface-mount ceramic capacitors typically have very-low ESR and are commonly available in values up to 10 μ F. Other low-ESR capacitors, such as surface-mount tantalum, may also be used. Do not use low-cost aluminum electrolytic capacitors due to their large size and relatively high ESR. Lastly, make sure the input and output capacitors are as close to the IC as possible to minimize the impact of PC board trace impedance.

200mA, Negative-Output, Low-Dropout Linear Regulator in SOT23

MAX1735

Noise, PSRR, and Transient Response

MAX1735 output noise is typically $160\mu\text{V}_{\text{RMS}}$. This is suitably low for most applications. See the Output Noise vs. Frequency plot in the *Typical Operating Characteristics*.

The MAX1735 is optimized for battery-powered equipment, with low dropout voltage and low quiescent current. It maintains good transient response, AC rejection, and noise characteristics even near dropout. See Power-Supply Rejection Ratio vs. Frequency in the *Typical Operating Characteristics*. When operating from very noisy sources, supply noise rejection and transient response can be improved by increasing the input and output capacitance, and by employing passive postfiltering.

Dropout Voltage

A regulator's minimum input-to-output voltage differential dropout voltage determines the lowest usable supply voltage for an application. In battery-powered systems, this determines the useful end-of-life battery voltage. Since the MAX1735's pass element is an N-channel MOSFET, dropout voltage is the product of $R_{\text{DS(ON)}}$ and the load current; see *Electrical Characteristics* and Dropout Voltage vs. Load Current in the *Typical Operating Characteristics* for details. The MAX1735 operating (ground pin) current typically remains below $125\mu\text{A}$ at full load in dropout.

Chip Information

TRANSISTOR COUNT: 293

200mA, Negative-Output, Low-Dropout Linear Regulator in SOT23

Package Information

(The package drawing(s) in this data sheet may not reflect the most current specifications. For the latest package outline information, go to www.maxim-ic.com/packages.)

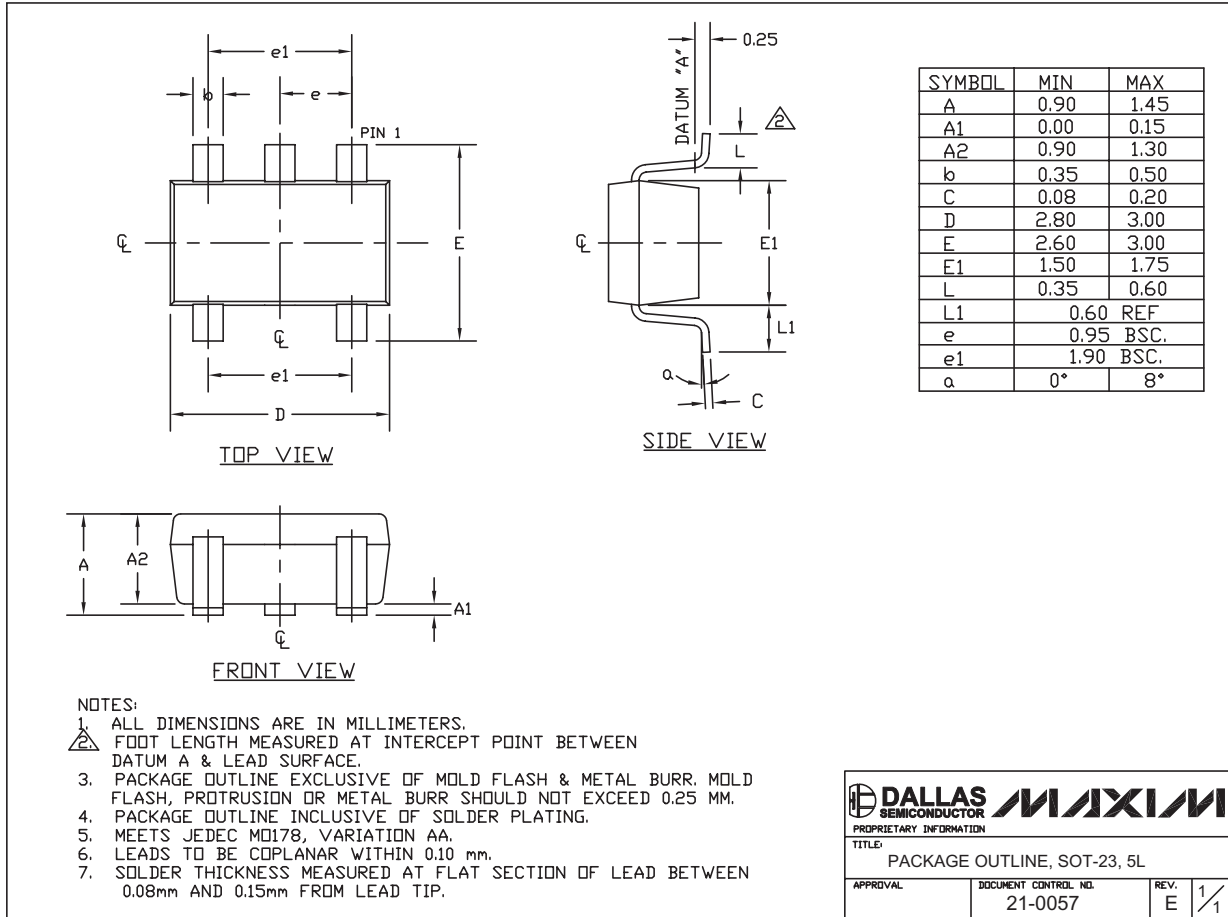

SOT-23 5L.EPS

Maxim cannot assume responsibility for use of any circuitry other than circuitry entirely embodied in a Maxim product. No circuit patent licenses are implied. Maxim reserves the right to change the circuitry and specifications without notice at any time.

10 **Maxim Integrated Products, 120 San Gabriel Drive, Sunnyvale, CA 94086 408-737-7600**

Looking for pricing, stock, or lifecycle information?

Click below to explore more details on WIN SOURCE:

 [View MAX1735EUK50-T on WIN SOURCE](#)

 [Maxim Integrated](#) Information

Optimize Your Supply Chain with WIN SOURCE Solutions

-  Global Sourcing Solution
-  Obsolete Management
-  Cost Control Management
-  Shortage Management
-  Alternative Solution
-  Excess Inventory Management