



**THE DATASHEET OF
MAX17499AAUB+**





Current-Mode PWM Controllers with Programmable Switching Frequency

General Description

The MAX17499/MAX17500 current-mode PWM controllers contain all the control circuitry required for the design of wide-input-voltage isolated and nonisolated power supplies. The MAX17499 is well suited for low input voltage (9.5V DC to 24V DC) power supplies. The MAX17500 is well suited for universal input (rectified 85V AC to 265V AC) or telecom (-36V DC to -72V DC) power supplies.

The ICs contain an internal error amplifier that regulates the tertiary winding output voltage that is used in primary-side-regulated isolated power supplies. Primary-side regulation eliminates the need for an optocoupler. An input undervoltage lockout (UVLO) is provided for programming the input-supply start voltage and to ensure proper operation during brownout conditions. An open-drain UVLO flag output, with 210 μ s internal delay, allows the sequencing of a secondary-side controller. The input-supply start voltage is externally programmable with a voltage-divider. A UVLO/EN input is used to shut down the devices. Internal digital soft-start eliminates output voltage overshoot.

The MAX17500 has an internal bootstrap UVLO with large hysteresis that requires a minimum 23.6V for startup. The MAX17499 does not have the internal bootstrap UVLO and can be biased directly from a minimum voltage of 9.5V.

The switching frequency for the ICs is programmable with an external resistor. The MAX17499A/MAX17500A provide a 50% maximum duty-cycle limit, while the MAX17499B/MAX17500B provide a 75% maximum duty-cycle limit. These devices are available in 10-pin μ MAX[®] packages and are rated for operation over the -40°C to +125°C temperature range.

Selector Guide appears at end of data sheet.

μ MAX is a registered trademark of Maxim Integrated Products, Inc.

Features

- ◆ Current-Mode Control
- ◆ Programmable Switching Frequency Up to 625kHz
- ◆ Accurate UVLO Threshold (1%)
- ◆ Open-Drain UVLO Flag Output with Internal Delay
- ◆ 36V to 72V Telecom Voltage Range
- ◆ Universal Offline Input Voltage Range
Rectified 85V AC to 265V AC (MAX17500)
- ◆ 9.5V to 24V Input (MAX17499)
- ◆ Digital Soft-Start
- ◆ Internal Bootstrap UVLO with Large Hysteresis (MAX17500)
- ◆ Internal Error Amplifier with 1.5% Accurate Reference
- ◆ 50 μ A (typ) Startup Supply Current
- ◆ 50% Maximum Duty-Cycle Limit (MAX17499A/MAX17500A)
- ◆ 75% Maximum Duty-Cycle Limit (MAX17499B/MAX17500B)
- ◆ 60ns Cycle-by-Cycle Current-Limit Propagation Delay
- ◆ Available in Tiny 10-Pin μ MAX Packages

Applications

- 1/2, 1/4, and 1/8 Brick Power Modules
- High-Efficiency, Isolated Telecom Power Supplies
- Networking/Servers
- Isolated Keep-Alive Power Supplies
- 12V Boost and SEPIC Regulators
- Isolated and Nonisolated High-Brightness LED Power Supplies
- Industrial Power Conversion

Ordering Information

PART	D _{MAX} (%)	STARTUP VOLTAGE (V)	TEMP RANGE	PIN-PACKAGE
MAX17499AAUB+	50	9.5	-40°C to +125°C	10 μ MAX
MAX17499BAUB+	75	9.5	-40°C to +125°C	10 μ MAX
MAX17500AAUB+	50	22	-40°C to +125°C	10 μ MAX
MAX17500BAUB+	75	22	-40°C to +125°C	10 μ MAX

Warning: The ICs are designed to work with high voltages. Exercise caution.

+Denotes a lead(Pb)-free/RoHS-compliant package.



Current-Mode PWM Controllers with Programmable Switching Frequency

ABSOLUTE MAXIMUM RATINGS

IN to GND	-0.3V to +30V
IN Clamp (internal shunt) Current	5mA
V _{CC} to GND	-0.3V to +13V
FB, COMP, UVLO/EN, RT, CS to GND	-0.3V to +6V
UFLG to GND	-0.3V to +30V
NDRV to GND	-0.3V to (V _{CC} + 0.3V)

Continuous Power Dissipation (T _A = +70°C)	
10-Pin μMAX (derate 5.6mW/°C above +70°C)	444.4mW
Operating Temperature Range	-40°C to +125°C
Storage Temperature Range	-65°C to +150°C
Junction Temperature	+150°C
Lead Temperature (soldering, 10s)	+300°C
Soldering Temperature (reflow)	+260°C

Stresses beyond those listed under "Absolute Maximum Ratings" may cause permanent damage to the device. These are stress ratings only, and functional operation of the device at these or any other conditions beyond those indicated in the operational sections of the specifications is not implied. Exposure to absolute maximum rating conditions for extended periods may affect device reliability.

ELECTRICAL CHARACTERISTICS

(V_{IN} = +12V (for MAX17500, bring V_{IN} up to 23.6V for startup), 10nF bypass capacitors at IN and V_{CC}, R12 = 15kΩ (MAX17499A/MAX17500A), R12 = 7.5kΩ (MAX17499B/MAX17500B), R15 = 1kΩ, C6 = 100nF (see the *Typical Application Circuit*), NDRV = open, V_{UVLO/EN} = +1.4V, V_{FB} = +1.0V, COMP = open, V_{CS} = 0V, T_A = -40°C to +125°C, unless otherwise noted. Typical values are at T_A = +25°C.) (Note 1)

PARAMETER	SYMBOL	CONDITIONS	MIN	TYP	MAX	UNITS
UVLO/STARTUP						
Bootstrap UVLO Wake-Up Level	V _{SUVR}	V _{IN} rising (MAX17500 only)	19.68	21.6	23.60	V
Bootstrap UVLO Shutdown Level	V _{SUVF}	V _{IN} falling (MAX17500 only)	9.05	9.74	10.43	V
UVLO/EN Wake-Up Threshold	V _{ULR2}	UVLO/EN rising	1.215	1.23	1.245	V
UVLO/EN Shutdown Threshold	V _{ULF2}	UVLO/EN falling	1.14	1.17	1.20	V
UVLO/EN Input Current	I _{UVLO}	V _{UVLO/EN} ≤ 2V	-50		+50	nA
UVLO/EN Hysteresis				60		mV
IN Supply Current In UVLO	I _{START}	V _{IN} = 19V, MAX17500 only when in bootstrap UVLO		50	90	μA
IN Input Voltage Range	V _{IN}	MAX17499 only	9.5		24.0	V
UVLO/EN to UFLG Propagation Delay (Figure 3)		UVLO/EN steps up from 1V to 1.4V		3		μs
		UVLO/EN steps down from 1.4V to 1V		0.6		
UVLO/EN to NDRV Propagation Delay (Figure 3)	t _{EXTR}	UVLO/EN steps up from 1V to 1.4V		3	10	ms
	t _{EXTF}	UVLO/EN steps down from 1.4V to 1V	150	210	300	
Bootstrap UVLO Propagation Delay	t _{BUVR}	V _{IN} steps up from 9V to 24V (MAX17500 only)		5		μs
	t _{BUVF}	V _{IN} steps down from 24V to 9V (MAX17500 only)		1		
UFLG Low Output Voltage	V _{UFLG}	I _{UFLG} = 5mA sinking			1.5	V
UFLG High Output Leakage Current		V _{UFLG} = 25V		0.1	1	μA
INTERNAL SUPPLY						
V _{CC} Regulator Set Point	V _{CCSP}	V _{IN} = 10.8V to 24V, sinking 1μA to 20mA from V _{CC}	7.0		10.5	V
IN Supply Current After Startup	I _{IN}	V _{IN} = 24V		2	4	mA
Shutdown Supply Current		UVLO/EN = low		50	90	μA

Current-Mode PWM Controllers with Programmable Switching Frequency

MAX17499/MAX17500

ELECTRICAL CHARACTERISTICS (continued)

($V_{IN} = +12V$ (for MAX17500, bring V_{IN} up to 23.6V for startup), 10nF bypass capacitors at IN and V_{CC} , $R_{12} = 15k\Omega$ (MAX17499A/MAX17500A), $R_{12} = 7.5k\Omega$ (MAX17499B/MAX17500B), $R_{15} = 1k\Omega$, $C_6 = 100nF$ (see the *Typical Application Circuit*), NDRV = open, $V_{UVLO/EN} = +1.4V$, $V_{FB} = +1.0V$, COMP = open, $V_{CS} = 0V$, $T_A = -40^{\circ}C$ to $+125^{\circ}C$, unless otherwise noted. Typical values are at $T_A = +25^{\circ}C$.) (Note 1)

PARAMETER	SYMBOL	CONDITIONS	MIN	TYP	MAX	UNITS
GATE DRIVER						
Driver Output Impedance	$R_{ON(LOW)}$	Measured at NDRV sinking 100mA		2	4	Ω
	$R_{ON(HIGH)}$	Measured at NDRV sourcing 20mA		4	10	
Driver Peak Sink Current				1		A
Driver Peak Source Current				0.65		A
PWM COMPARATOR						
Comparator Offset Voltage	V_{PWM}	$V_{COMP} - V_{CS}$	1.24	1.38	1.54	V
CS Input Bias Current	I_{CS}	$V_{CS} = 0V$	-4		+4	μA
Comparator Propagation Delay	t_{PWM}	Change in $V_{CS} = 0.1V$		60		ns
CURRENT-LIMIT COMPARATOR						
Current-Limit Trip Threshold	V_{CS}		900	1000	1100	mV
CS Input Bias Current	I_{CS}	$V_{CS} = 0V$	-4		+4	μA
Propagation Delay from Comparator Input to NDRV	t_{PDCS}	100mV overdrive		60		ns
IN CLAMP VOLTAGE						
IN Clamp Voltage	V_{INC}	2mA sink current (Note 2)	24.1	26.1	29.0	V
ERROR AMPLIFIER						
Voltage Gain		$R_{LOAD} = 100k\Omega$		80		dB
Unity-Gain Bandwidth		$R_{LOAD} = 100k\Omega$, $C_{LOAD} = 200pF$		2		MHz
Phase Margin		$R_{LOAD} = 100k\Omega$, $C_{LOAD} = 200pF$		65		Degrees
FB Input Offset Voltage				± 1		mV
COMP High Voltage		$I_{COMP} = 0A$	2.5			V
COMP Low Voltage		$I_{COMP} = 0A$			1.1	V
Source Current			0.5			mA
Sink Current			0.5			mA
Reference Voltage	V_{REF}	(Note 3)		1.230		V
Reference Voltage Accuracy			-1.5		+1.5	%
FB Input Bias Current			-50		+50	nA
COMP Short-Circuit Current				8		mA
DIGITAL SOFT-START						
Soft-Start Duration	t_{SS}			1984		NDRV cycles
		$f_{SW} = 350kHz$		5.6		ms
Reference Voltage Steps During Soft-Start				31		Steps
Reference Voltage Step				39.67		mV

Current-Mode PWM Controllers with Programmable Switching Frequency

ELECTRICAL CHARACTERISTICS (continued)

($V_{IN} = +12V$ (for MAX17500, bring V_{IN} up to 23.6V for startup), 10nF bypass capacitors at IN and V_{CC} , $R12 = 15k\Omega$ (MAX17499A/MAX17500A), $R12 = 7.5k\Omega$ (MAX17499B/MAX17500B), $R15 = 1k\Omega$, $C6 = 100nF$ (see the *Typical Application Circuit*), NDRV = open, $V_{UVLO/EN} = +1.4V$, $V_{FB} = +1.0V$, COMP = open, $V_{CS} = 0V$, $T_A = -40^\circ C$ to $+125^\circ C$, unless otherwise noted. Typical values are at $T_A = +25^\circ C$.) (Note 1)

PARAMETER	SYMBOL	CONDITIONS	MIN	TYP	MAX	UNITS
OSCILLATOR						
Oscillator Frequency Range	f_{OSC}		50		2500	kHz
Oscillator Frequency Accuracy		$f_{OSC} = 200kHz$ to $800kHz$	-10		+10	%
		$f_{OSC} = 50kHz$ to $250kHz$	-20		+20	
NDRV Switching Frequency (Note 4)	f_{SW}	MAX17499A/MAX17500A, $f_{SW} = f_{OSC}/2$	25		625	kHz
		MAX17499B/MAX17500B, $f_{SW} = f_{OSC}/4$	12.5		625.0	
Maximum Duty Cycle	D_{MAX}	MAX17499A/MAX17500A		50		%
		MAX17499B/MAX17500B		75		

Note 1: All devices are 100% tested at $T_A = +125^\circ C$. All limits over temperature are guaranteed by characterization.

Note 2: The MAX17500 is intended for use in universal input power supplies. The internal clamp circuit at IN is used to prevent the bootstrap capacitor (C1 in Figure 1) from charging to a voltage beyond the absolute maximum rating of the device when UVLO/EN is low (shutdown mode). Externally limit the maximum current to IN (hence to clamp) to 2mA maximum when UVLO/EN is low. Clamp currents higher than 2mA may result in a clamp voltage higher than 30V, thus exceeding the absolute maximum rating for IN. For the MAX17499, do not exceed the 24V maximum operating voltage of the device.

Note 3: V_{REF} is measured with FB connected to COMP (see the *Functional Diagram*).

Note 4: The oscillator in the MAX17499A/MAX17500A is capable of operating up to 2500kHz. However, the NDRV switching frequency is limited to operate up to 625kHz. Thus, the oscillator frequency for the MAX17499A/MAX17500A must be limited to 1250kHz (maximum).

Typical Operating Characteristics

($V_{UVLO/EN} = +1.4V$, $V_{FB} = +1V$, COMP = open, $V_{CS} = 0V$, $T_A = +25^\circ C$, unless otherwise noted.)

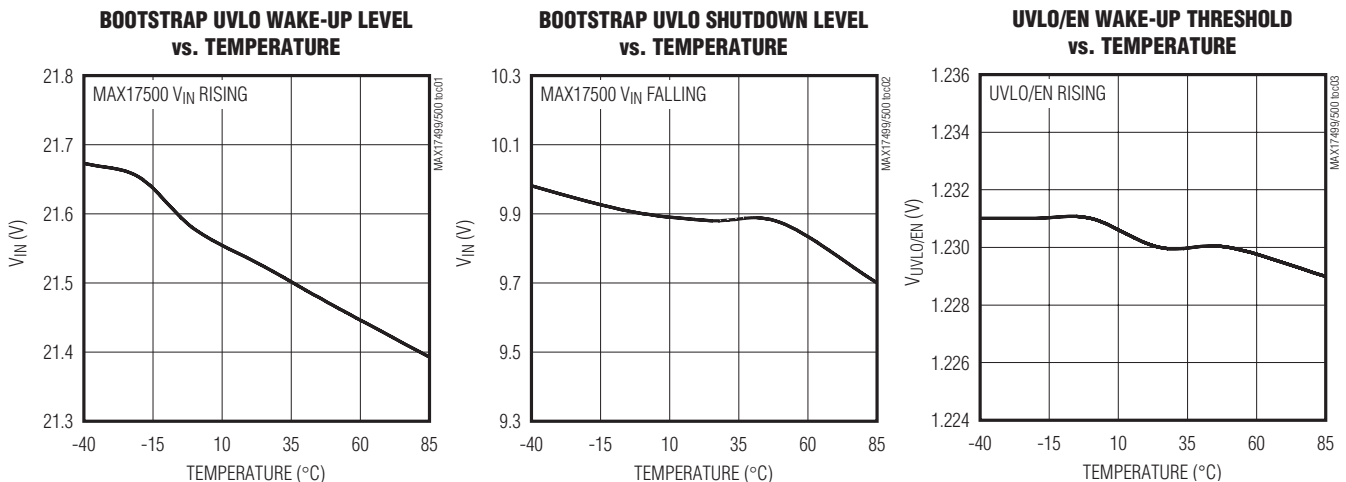

Current-Mode PWM Controllers with Programmable Switching Frequency

Typical Operating Characteristics (continued)

($V_{UVLO/EN} = +1.4V$, $V_{FB} = +1V$, COMP = open, $V_{CS} = 0V$, $T_A = +25^\circ C$, unless otherwise noted.)

MAX17499/MAX17500

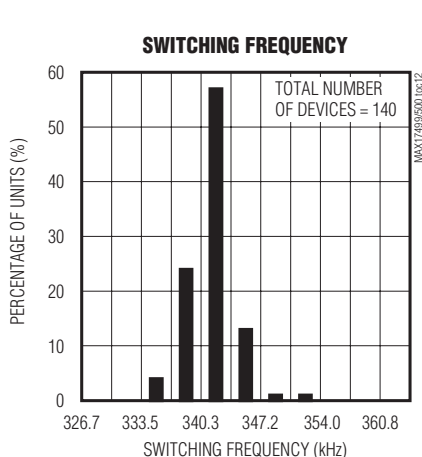
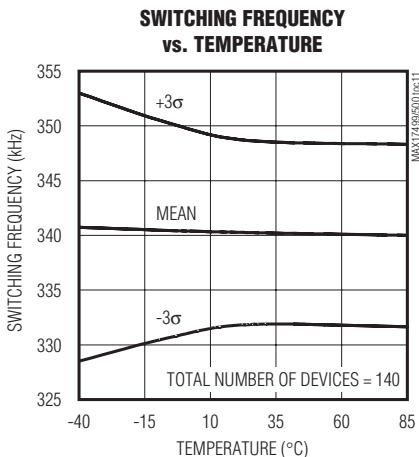
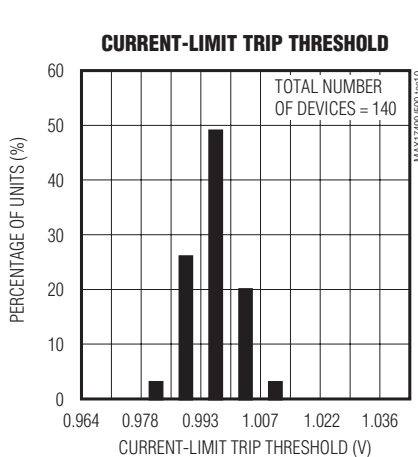
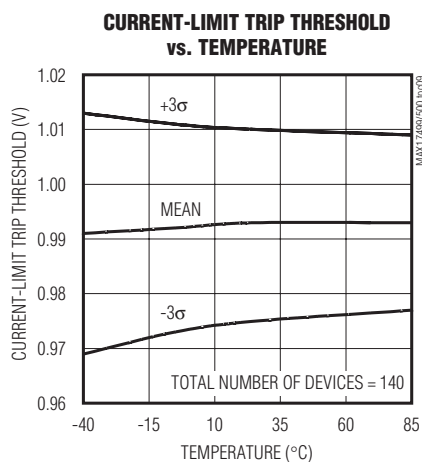
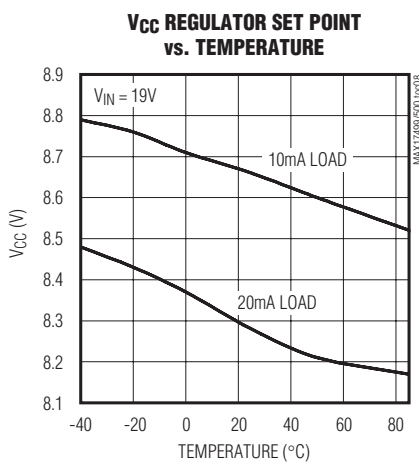
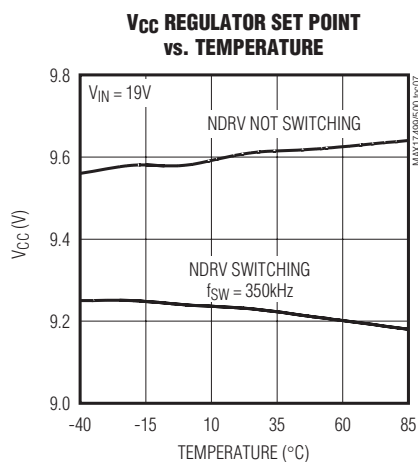
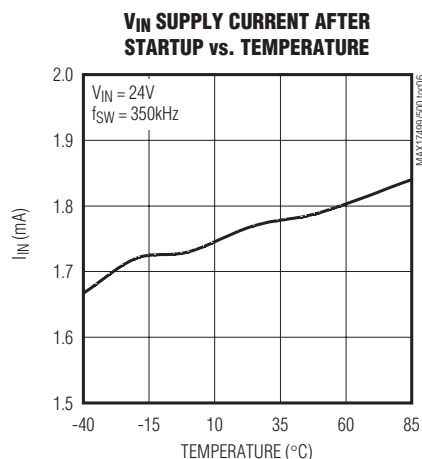
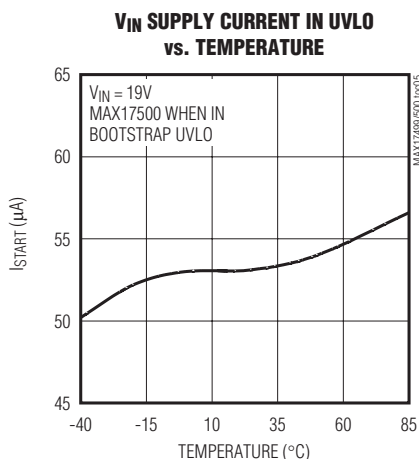
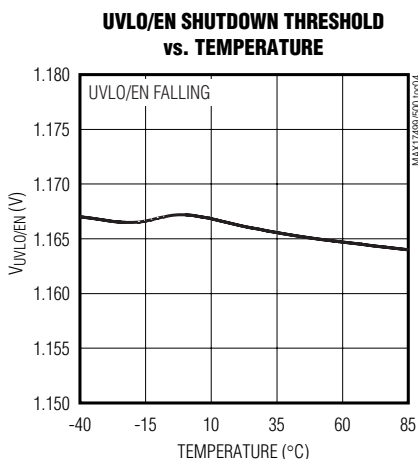

Current-Mode PWM Controllers with Programmable Switching Frequency

Typical Operating Characteristics (continued)

($V_{UVLO/EN} = +1.4V$, $V_{FB} = +1V$, COMP = open, $V_{CS} = 0V$, $T_A = +25^\circ C$, unless otherwise noted.)

SWITCHING FREQUENCY vs. TIMING RESISTOR

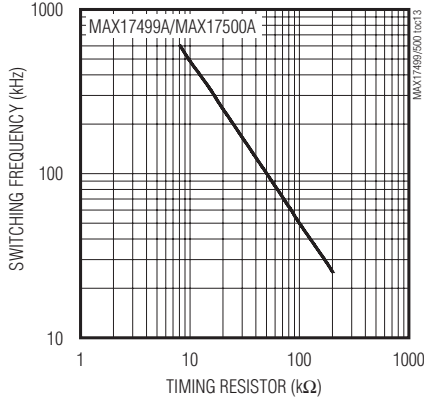

PROPAGATION DELAY FROM CURRENT-LIMIT COMPARATOR INPUT TO NDRV vs. TEMPERATURE

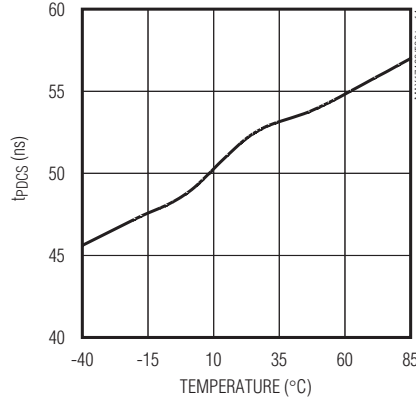

UVLO/EN-TO-NDRV PROPAGATION DELAY vs. TEMPERATURE

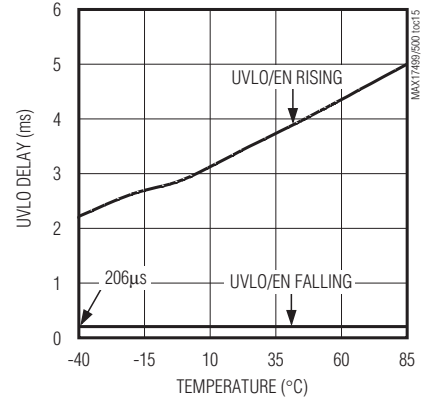

UVLO/EN-TO-UFLG PROPAGATION DELAY vs. TEMPERATURE

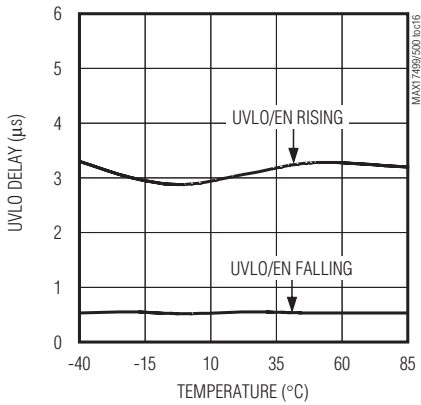

REFERENCE VOLTAGE vs. TEMPERATURE

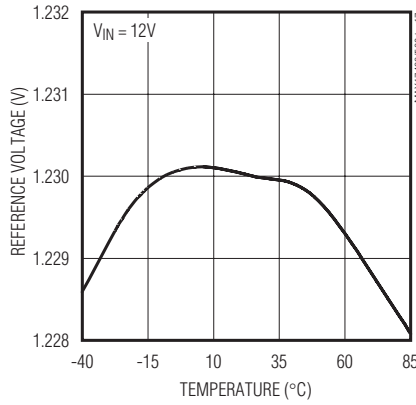

INPUT CURRENT vs. IN VOLTAGE

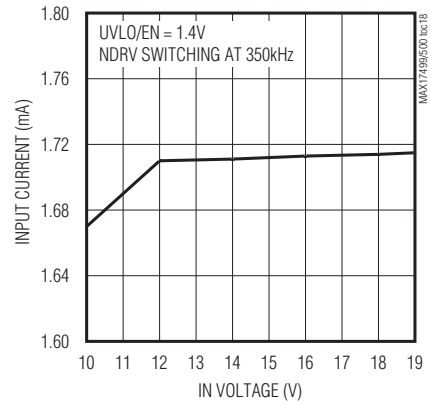

INPUT CLAMP VOLTAGE vs. TEMPERATURE

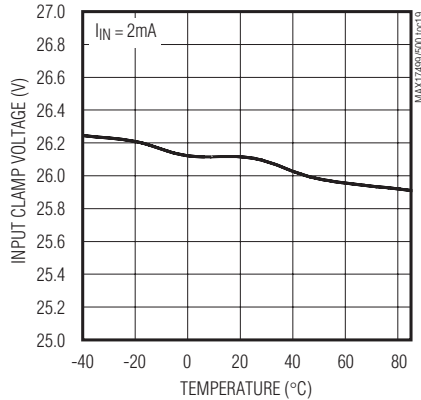

NDRV LOW-OUTPUT IMPEDANCE vs. TEMPERATURE

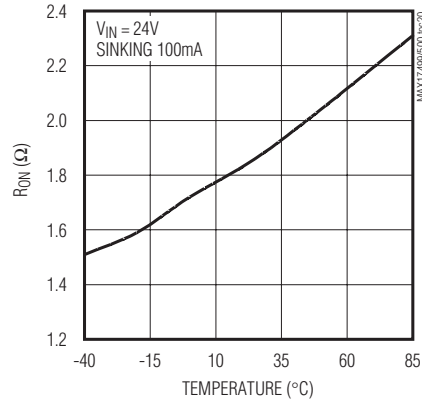

Current-Mode PWM Controllers with Programmable Switching Frequency

Typical Operating Characteristics (continued)

($V_{UVLO/EN} = +1.4V$, $V_{FB} = +1V$, COMP = open, $V_{CS} = 0V$, $T_A = +25^\circ C$, unless otherwise noted.)

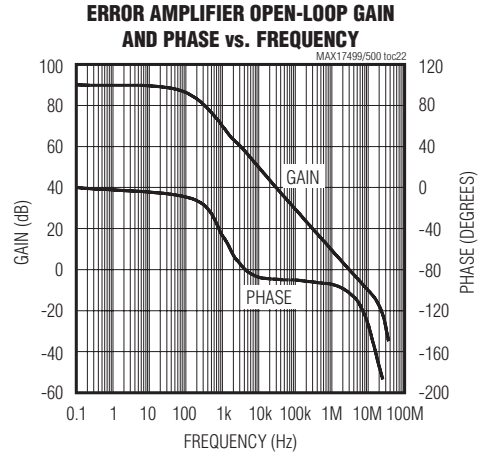
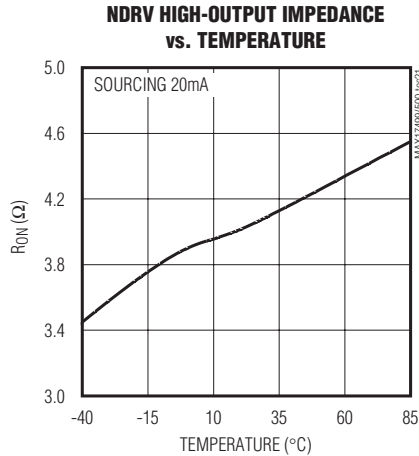

Pin Configuration

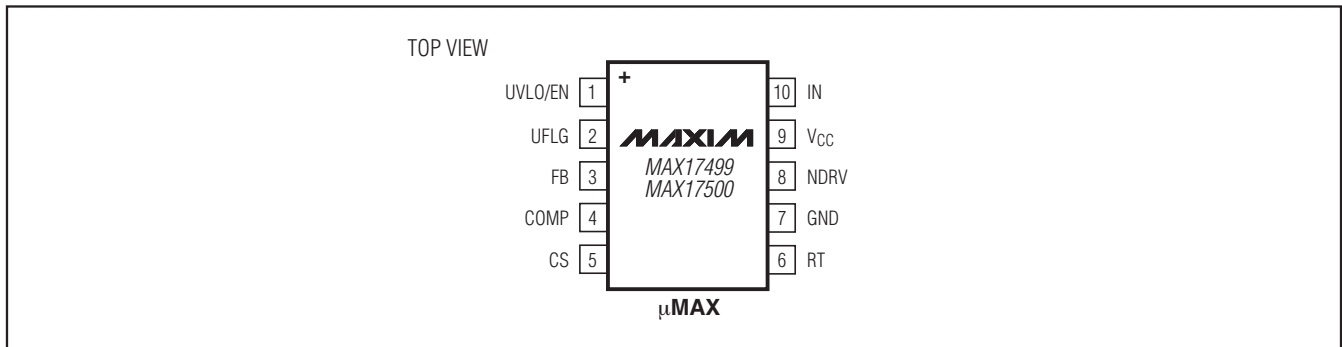

Pin Description

PIN	NAME	FUNCTION
1	UVLO/EN	Externally Programmable Undervoltage Lockout. UVLO/EN programs the input start voltage. Connect UVLO/EN to GND to disable the device. NDRV stops switching approximately 210μs after the UVLO/EN voltage falls below 1.17V.
2	UFLG	Open-Drain Undervoltage Flag Output. UFLG is asserted low as soon as the UVLO/EN voltage falls below its threshold.
3	FB	Error-Amplifier Inverting Input
4	COMP	Error-Amplifier Output
5	CS	Current-Sense Input. Current-sense connection for PWM regulation and cycle-by-cycle current limit. Connect to the high side of the sense resistor. An RC filter may be necessary to eliminate leading-edge spikes. Current-limit trip voltage is 1V.
6	RT	Oscillator Timing Resistor Input. An RC network may be required to reduce jitter (see the <i>Typical Application Circuit</i>).

Current-Mode PWM Controllers with Programmable Switching Frequency

Pin Description (continued)

PIN	NAME	FUNCTION
7	GND	Ground Connection
8	NDRV	External n-Channel MOSFET Gate Connection
9	VCC	Gate-Drive Supply. Internally generated supply from IN. Decouple V _{CC} with a 10nF or larger capacitor to GND.
10	IN	IN Supply. Decouple with a 10nF or larger capacitor to GND. For bootstrapped operation (MAX17500), connect a startup resistor from the input supply line to IN. Connect the bias winding supply to IN also (see the <i>Typical Application Circuit</i>). For the MAX17499, connect IN directly to the 9.5V to 24V supply.

Detailed Description

The MAX17499/MAX17500 current-mode PWM controllers are ideal for isolated and nonisolated power-supply applications. The devices offer an accurate input startup voltage programmable through the UVLO/EN input. This feature prevents the power supply from entering a brownout condition in case the input voltage sags below its minimum value. This is important since switching power supplies increase their input supply current as the input voltage drops to keep the output power constant. In addition to this externally adjustable UVLO feature, the MAX17500 also offers a bootstrap UVLO with a large hysteresis (11.9V) and very low startup and operating current, which result in

an efficient universal input power supply. The switching frequency of the devices is programmable with an external resistor.

The MAX17500 is well suited for universal input (rectified 85V AC to 265V AC) or telecom (-36V DC to -72V DC) power supplies. The MAX17499 is well suited for low-input-voltage (9.5V DC to 24V DC) power supplies. The devices include an internal clamp at IN to prevent the input voltage from exceeding the absolute maximum rating (see Note 2 at the end of the *Electrical Characteristics* table). The input is clamped when the devices are started with a bleed resistor (R1 in Figure 1) from a high input voltage and the UVLO/EN input is low. The clamp can safely sink up to 2mA current.

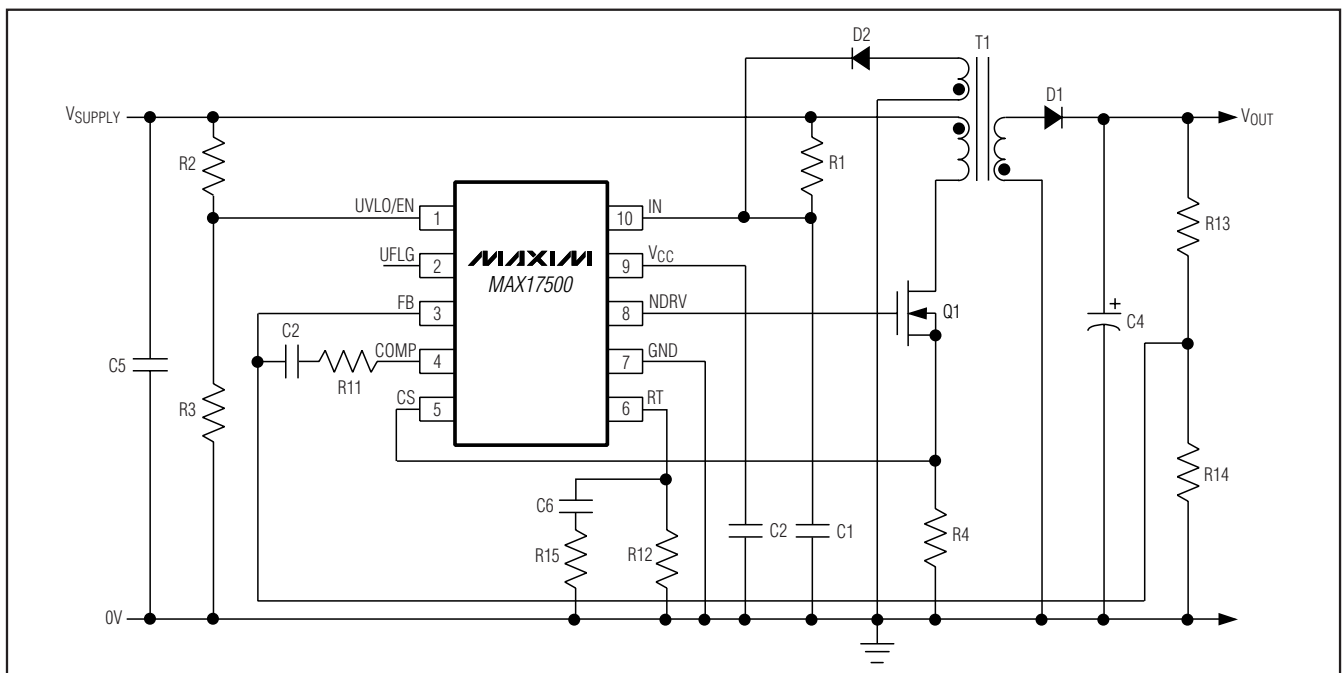

Figure 1. Nonisolated Power Supply with Programmable Input-Supply Start Voltage

Current-Mode PWM Controllers with Programmable Switching Frequency

Power supplies designed with the MAX17500 use a high-value startup resistor, R1, that charges a reservoir capacitor, C1 (see Figure 1). During this initial period, while the voltage is less than the internal bootstrap UVLO threshold, the device typically consumes only 50μA of quiescent current. This low startup current and the large bootstrap UVLO hysteresis help to minimize the power dissipation across R1 even at the high end of the universal AC input voltage (265V AC).

The devices include a cycle-by-cycle current limit that turns off the gate drive to the external MOSFET whenever the internally set threshold of 1V is exceeded. When using the MAX17500 in bootstrapped mode, if the power-supply output is shorted, the tertiary winding voltage drops below the internally set threshold causing the UVLO to turn off the gate drive to the external power MOSFET. This reinitiates a startup sequence with soft-start.

Current-Mode Control Loop

The advantages of current-mode control over voltage-mode control are twofold. First, there is the feed-forward characteristic brought on by the controller's ability to adjust for variations in the input voltage on a cycle-by-cycle basis. Secondly, the stability requirements of the current-mode controller are reduced to that of a single-pole system unlike the double pole in voltage-mode control.

The devices use a current-mode control loop where the output of the error amplifier (COMP) is compared to the current-sense voltage at CS. When the current-sense signal is lower than the noninverting input of the CPWM comparator, the output of the CPWM comparator is low and the switch is turned on at each clock pulse. When the current-sense signal is higher than the inverting input of the CPWM, the output of the CPWM comparator goes high and the switch is turned off.

Undervoltage Lockout

The devices provide a UVLO/EN input. The threshold for UVLO is 1.23V with 60mV hysteresis. Before any operation can commence, the voltage on UVLO/EN has to exceed 1.23V. The UVLO circuit keeps the CPWM comparator, ILIM comparator, oscillator, and output driver shut down to reduce current consumption (see the *Functional Diagram*).

Use this UVLO/EN input to program the input-supply start voltage. For example, a reasonable start voltage for a 36V to 72V telecom range is usually 34V. Calculate the resistor-divider values, R2 and R3 (see Figure 1) by using the following formulas:

$$R3 \cong \frac{V_{ULR2} V_{IN}}{500 I_{UVLO} (V_{IN} - V_{ULR2})}$$

$$R2 = \frac{V_{IN} - V_{ULR2}}{V_{ULR2}} R3$$

where I_{UVLO} is the UVLO/EN input current (50nA max), and V_{ULR2} is the UVLO/EN wake-up threshold (1.23V). V_{IN} is the value of the input-supply voltage where the power supply must start. The value of R3 is calculated to minimize the voltage-drop error across R2 as a result of the input bias current of the UVLO/EN input.

MAX17500 Bootstrap UVLO

In addition to the externally programmable UVLO function offered in both devices, the MAX17500 includes an internal bootstrap UVLO that is very useful when designing high-voltage power supplies (see the *Functional Diagram*). This allows the device to bootstrap itself during initial power-up. The MAX17500 attempts to start when V_{IN} exceeds the bootstrap UVLO threshold of 21.6V. During startup, the UVLO circuit keeps the CPWM comparator, ILIM comparator, oscillator, and output driver shut down to reduce current consumption. Once V_{IN} reaches 21.6V, the UVLO circuit turns on the CPWM and ILIM comparators, the oscillator, and allows the output driver to switch. If V_{IN} drops below 1.17V, the UVLO circuit shuts down the CPWM comparator, ILIM comparator, oscillator, and output driver returning the MAX17500 to the low-current startup mode.

Startup Operation

The MAX17499 starts up when the voltage at IN exceeds 9.5V and the UVLO/EN input is greater than 1.23V. However, the MAX17500 requires that, in addition to meeting the specified startup conditions for the MAX17499, the voltage at IN exceeds the bootstrap UVLO threshold of 21.6V.

Current-Mode PWM Controllers with Programmable Switching Frequency

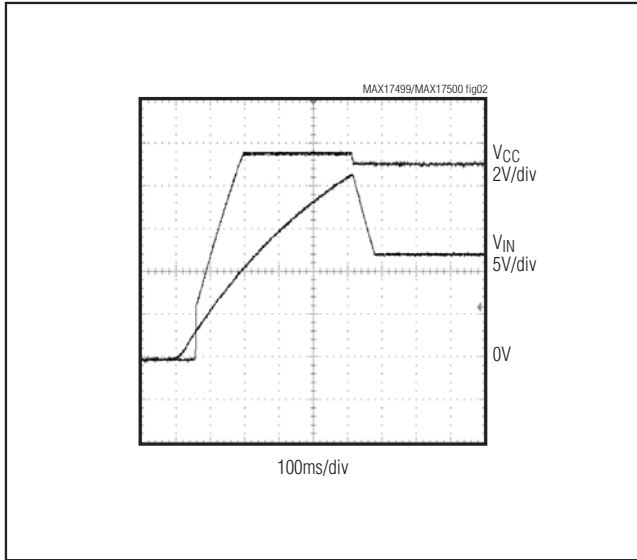

Figure 2. V_{IN} and V_{CC} During Startup When Using the MAX17500 in Bootstrapped Mode (Figure 1)

For the MAX17500, the voltage at IN is normally derived from a tertiary winding of the transformer. However, at startup there is no energy being delivered through the transformer; hence, a special bootstrap sequence is required. Figure 2 shows the voltages at V_{IN} and V_{CC} during startup. Initially, both V_{IN} and V_{CC} are 0V. After the line voltage is applied, C1 charges through the startup resistor, R1, to an intermediate voltage. At this

point, the internal regulator begins charging C2 (see Figure 1). Only 50 μ A of the current supplied through R1 is used by the MAX17500; the remaining input current charges C1 and C2. The charging of C2 stops when the V_{CC} voltage reaches approximately 9.5V, while the voltage across C1 continues rising until it reaches the wake-up level of 21.6V. Once V_{IN} exceeds the bootstrap UVLO threshold, NDRV begins switching the MOSFET and transfers energy to the secondary and tertiary outputs. If the voltage on the tertiary output builds to higher than 9.74V (the bootstrap UVLO lower threshold), then startup has been accomplished and sustained operation commences. If V_{IN} drops below 9.74V before startup is complete, the device goes back to low-current UVLO. In this case, increase the value of C1 to store enough energy to allow for the voltage at the tertiary winding to build up.

UVLO Flag (UFLG)

The devices have an open-drain undervoltage flag output (UFLG). When used with an optocoupler, the UFLG output can serve to sequence a secondary-side controller. An internal 210 μ s delay occurs the instant the voltage on UVLO/EN drops below 1.17V until NDRV stops switching. This allows for the UFLG output to change state before the devices shut down (Figure 3).

When the voltage at the UVLO/EN is above the threshold, UFLG is high impedance. When UVLO/EN is below the threshold, UFLG goes low. UFLG is not affected by bootstrap UVLO (MAX17500).

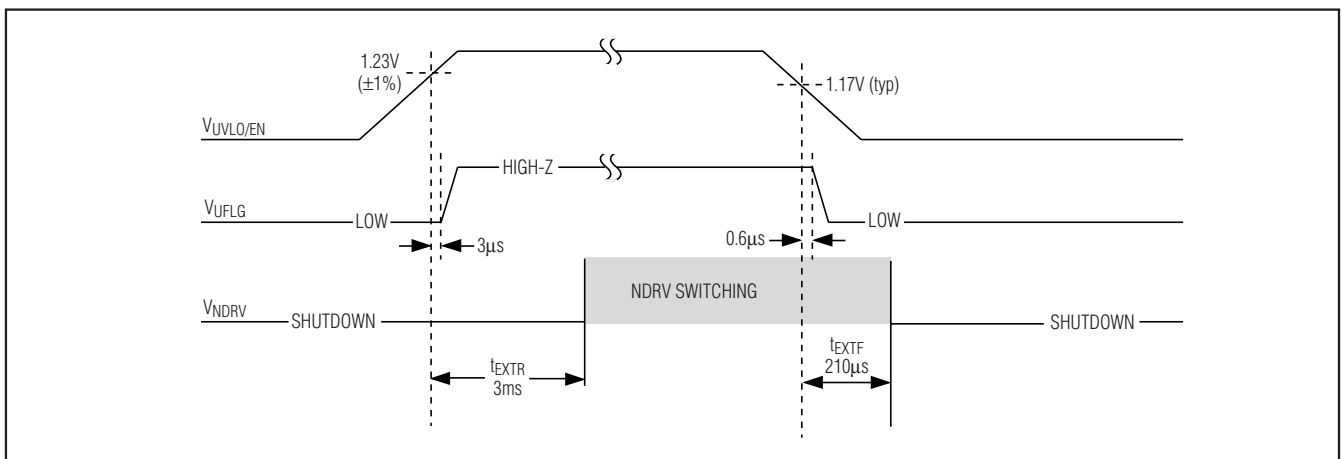

Figure 3. UVLO/EN and UFLG Operation Timing

Current-Mode PWM Controllers with Programmable Switching Frequency

MAX17499/MAX17500

Soft-Start

The devices' soft-start feature allows the output voltage to ramp up in a controlled manner, eliminating voltage overshoot. The devices' reference generator that is internally connected to the error amplifier soft-starts to achieve superior control of the output voltage under heavy- and light-load conditions. Soft-start begins after UVLO is deasserted (V_{IN} is above 21.6V for the MAX17500, V_{IN} is above 9.5V for the MAX17499, and the voltage on UVLO/EN is above 1.23V). The voltage applied to the noninverting node of the amplifier ramps from 0 to 1.23V in 1984 NDRV switching cycles. Use the following formula to calculate the soft-start time (t_{SS}):

$$t_{SS} = \frac{1984}{f_{NDRV}}$$

where f_{NDRV} is the switching frequency at the NDRV output. Figure 4 shows the soft-start regulated output of a power supply using the MAX17500 during startup.

n-Channel MOSFET Switch Driver

The NDRV output drives an external n-channel MOSFET. The internal regulator output (V_{CC}), set to approximately 9V, drives NDRV. For the universal input voltage range, the MOSFET used must withstand the DC level of the high-line input voltage plus the reflected voltage at the primary of the transformer. Most applications that use the discontinuous flyback topology require a MOSFET rated at 600V. NDRV can source/sink in excess of 650mA/1000mA peak current; therefore, select a MOSFET that mA yields acceptable conduction and switching losses.

Oscillator/Switching Frequency

Use an external resistor at RT to program the devices' internal oscillator frequency between 50kHz and 2.5MHz. The MAX17499A/MAX17500A output switching frequency is one-half the programmed oscillator frequency with a 50% duty cycle. The MAX17499B/MAX17500B output switching frequency is one-quarter of the programmed oscillator frequency with a 75% duty cycle.

The MAX17499A/MAX17500A and MAX17499B/MAX17500B have programmable output switching frequencies from 25kHz to 625kHz and 12.5kHz to 625kHz, respectively. Use the following formulas to determine the appropriate value of resistor R12 (see Figure 1) needed to generate the desired output switching frequency (f_{sw}) at the NDRV output:

$$R12 = \frac{10^{10}}{2f_{sw}} \text{ for the MAX17499A/MAX17500A.}$$

$$R12 = \frac{10^{10}}{4f_{sw}} \text{ for the MAX17499B/MAX17500B.}$$

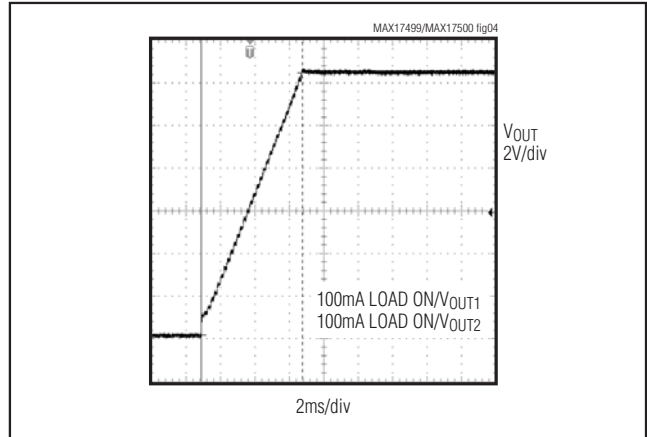

Figure 4. Primary-Side Output Voltage Soft-Start During Initial Startup for the Circuit in Figure 6

where R12 is the resistor connected from RT to GND (see Figure 1).

Connect an RC network in parallel with R12 as shown in Figure 1. The RC network should consist of a 100nF capacitor, C6, (for stability) in series with resistor R15, which serves to further minimize jitter. Use the following formula to determine the value of R15:

$$R15 = 88.9 \times (R12)^{\frac{1}{4}}$$

For example, if R12 is 4k Ω , R15 becomes 707 Ω .

Internal Error Amplifier

The devices include an internal error amplifier to regulate the output voltage in the case of a nonisolated power supply (see Figure 1). For the circuit in Figure 1, calculate the output voltage using the following equation:

$$V_{OUT} = \left(1 + \frac{R13}{R14}\right) V_{REF}$$

where $V_{REF} = 1.23V$. The amplifier's noninverting input is internally connected to a digital soft-start circuit that gradually increases the reference voltage during start-up applied to this input. This forces the output voltage to come up in an orderly and well-defined manner under all load conditions.

The error amplifier may also be used to regulate the tertiary winding output, which implements a primary-side-regulated, isolated power supply (see Figure 6). For the

Current-Mode PWM Controllers with Programmable Switching Frequency

circuit in Figure 6, calculate the output voltage using the following equation:

$$V_{OUT} = \frac{N_S}{N_T} \left[\left(1 + \frac{R_1}{R_2} \right) V_{REF} + V_{D6} \right] - V_{D2}$$

where N_S is the number of secondary winding turns, N_T is the number of tertiary winding turns, and both V_{D6} and V_{D2} are the diode drops at the respective outputs.

Current Limit

The current-sense resistor (R_4 in Figure 1), connected between the source of the MOSFET and ground, sets the current limit. The current-limit comparator has a voltage trip level (V_{CS}) of 1V. Use the following equation to calculate the value of R_4 :

$$R_4 = \frac{V_{CS}}{I_{PRI}}$$

where I_{PRI} is the peak current in the primary side of the transformer, which also flows through the MOSFET. When the voltage produced by this current (through the current-sense resistor) exceeds the current-limit comparator threshold, the MOSFET driver (NDRV) terminates the current on-cycle within 60ns (typ). Use a small RC network to filter out the leading-edge spikes on the sensed waveform when needed. Set the corner frequency between 2MHz and 10MHz.

Applications Information

Startup Time Considerations for Power Supplies Using the MAX17500

The bypass capacitor at I_N , C_1 , supplies current immediately after the MAX17500 wakes up (see Figure 1). The size of C_1 and the connection configuration of the tertiary winding determine the number of cycles available for startup. Large values of C_1 increase the start-up time but also supply gate charge for more cycles during initial startup. If the value of C_1 is too small, V_{IN} drops below 9.74V because NDRV does not have enough time to switch and build up sufficient voltage across the tertiary output, which powers the device. The device goes back into UVLO and does not start. Use a low-leakage capacitor for C_1 and C_2 .

Typically, offline power supplies keep startup times to less than 500ms even in low-line conditions (85V AC input for universal offline or 36V DC for telecom applications). Size the startup resistor, R_1 , to supply both

the maximum startup bias of the device ($90\mu\text{A}$) and the charging current for C_1 and C_2 . The bypass capacitor, C_2 , must charge to 9.5V and C_1 to 24V, all within the desired time period of 500ms. Because of the internal soft-start time of the MAX17500 (approximately 5.6ms when $f_{sw} = 350\text{kHz}$), C_1 must store enough charge to deliver current to the device for at least this much time. To calculate the approximate amount of capacitance required, use the following formula:

$$I_G = Q_{GTOT} f_{sw}$$

$$C_1 = \frac{(I_{IN} + I_G)(t_{SS})}{V_{HYST}}$$

where I_{IN} is the MAX17500's internal supply current (2mA) after startup, Q_{GTOT} is the total gate charge for Q_1 , f_{sw} is the MAX17500's switching frequency (350kHz), V_{HYST} is the bootstrap UVLO hysteresis (approximately 12V), and t_{SS} is the internal soft-start time (5.6ms).

Example: $I_G = (8\text{nC})(350\text{kHz}) \cong 2.8\text{mA}$

$$C_1 = \frac{(2\text{mA} + 2.8\text{mA})(5.6\text{ms})}{12\text{V}} = 2.24\mu\text{F}$$

Choose a 2.2 μF standard value (assuming 350kHz switching frequency).

Assuming $C_1 > C_2$, calculate the value of R_1 as follows:

$$I_{C1} = \frac{V_{SUVR} C_1}{(500\text{ms})}$$

$$R_1 \cong \frac{V_{IN(MIN)} - V_{SUVR}}{I_{C1} + I_{START}}$$

where $V_{IN(MIN)}$ is the minimum input supply voltage for the application (36V for telecom), V_{SUVR} is the bootstrap UVLO wake-up level (23.6V max), and I_{START} is the I_N supply current at startup ($90\mu\text{A}$ max).

For example:

$$I_{C1} = \frac{(24\text{V})(2.2\mu\text{F})}{(500\text{ms})} = 0.105\text{mA}$$

$$R_1 \cong \frac{(36\text{V}) - (24\text{V})}{(0.105\text{mA}) + (90\mu\text{A})} = 61.5\text{k}\Omega$$

Choose a 61.9k Ω standard value.

Current-Mode PWM Controllers with Programmable Switching Frequency

Choose a higher value for R1 than the one calculated in the previous equation if a longer startup time can be tolerated to minimize power loss on this resistor.

The above startup method is applicable to a circuit similar to the one shown in Figure 1. In this circuit, the tertiary winding has the same phase as the output windings. Thus, the voltage on the tertiary winding at any given time is proportional to the output voltage and goes through the same soft-start period as the output voltage. The minimum discharge time of C1 from 21.6V to 9.74V must be greater than the soft-start time of 5.6ms.

Another method for bootstrapping the power supply is to use a bias winding that is in-phase with the MOSFET on-time (see Figure 5). In this case, the amount of capacitance required at IN (C1) is much smaller. However, the input voltage cannot have a range greater than approximately 2:1 (primary-winding voltage to bias-winding voltage ratio).

For hiccup-mode fault protection, make the bias winding in-phase with the output, then the power-supply hiccups and soft-starts under output short-circuit conditions. The power supply does not hiccup if the bias winding is in-phase with the MOSFET on-time.

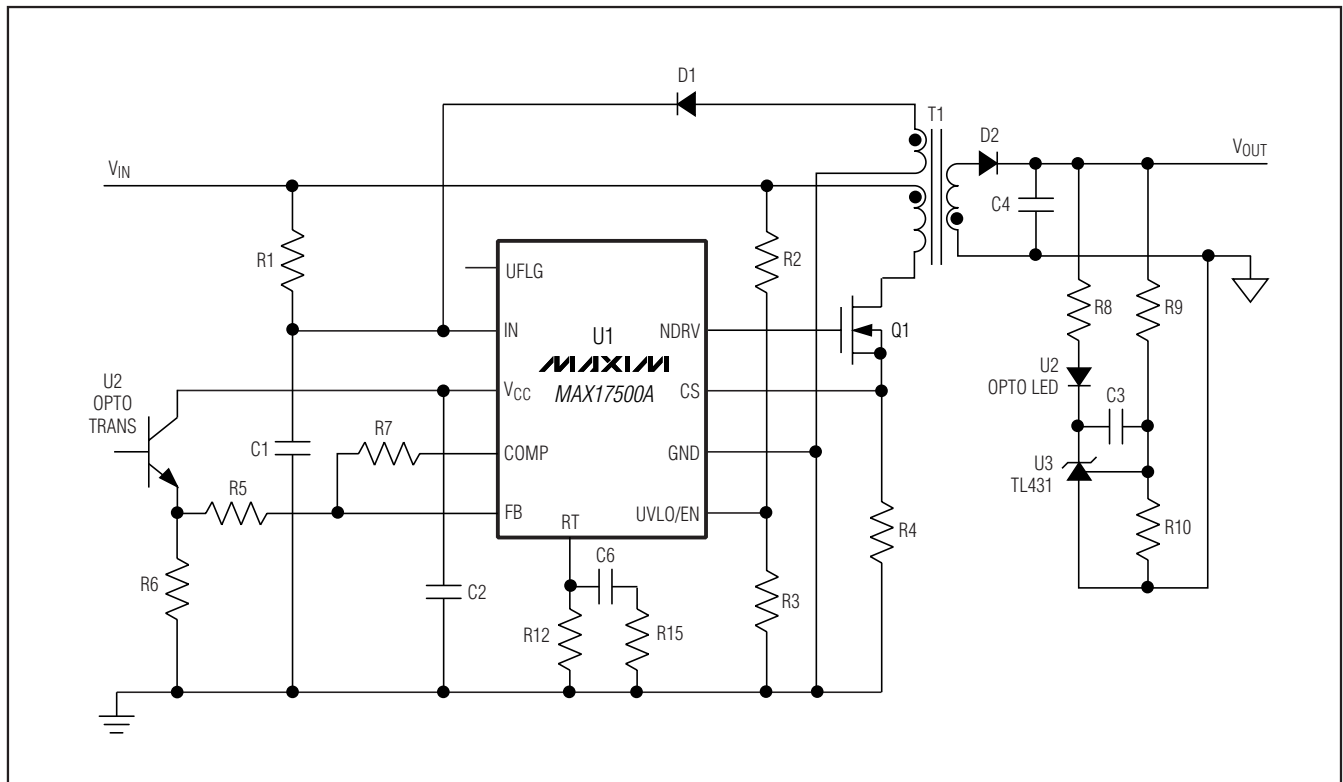

Figure 5. Secondary-Side Regulated, Isolated Power Supply

Current-Mode PWM Controllers with Programmable Switching Frequency

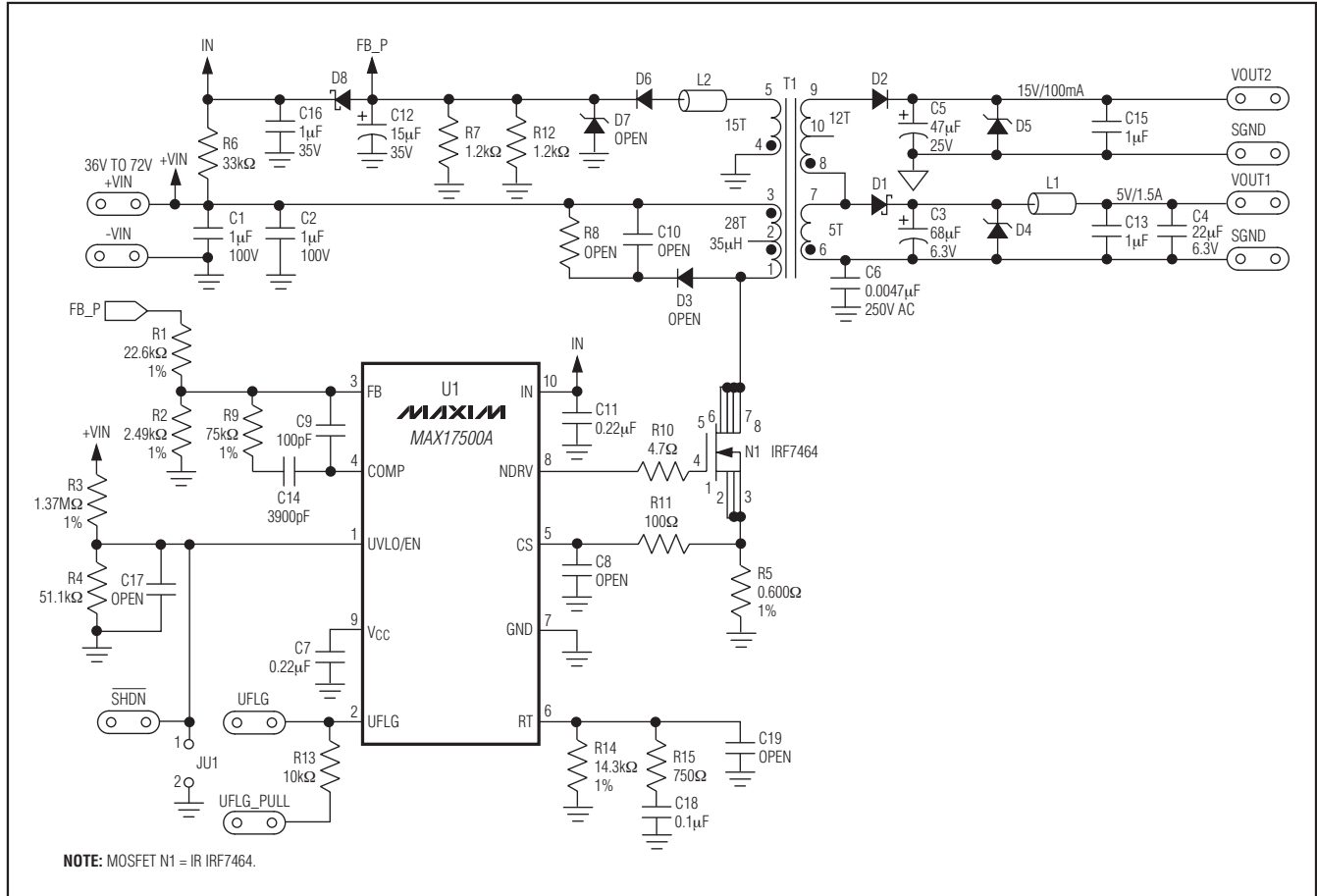

Figure 6. Primary-Side-Regulated, Dual-Output, Isolated Telecom Power Supply

Primary-Side-Regulated, Isolated Telecom Power Supply

Figure 6 shows a complete circuit of a dual-output power supply with a 36V to 72V telecom voltage range. An important aspect of this power supply is that it is primary-side regulated. The regulation through the tertiary winding also supplies bias for the MAX17500.

In the circuit of Figure 6, cross-regulation has been improved (tertiary and 5V outputs) by using chip inductors, L1 and L2, and R7 || R12 across C12. R7 || R12 presents enough loading on the tertiary winding output to allow $\pm 10\%$ load regulation on the 5V output over a 150mA to 1.5A load current range (Figure 7).

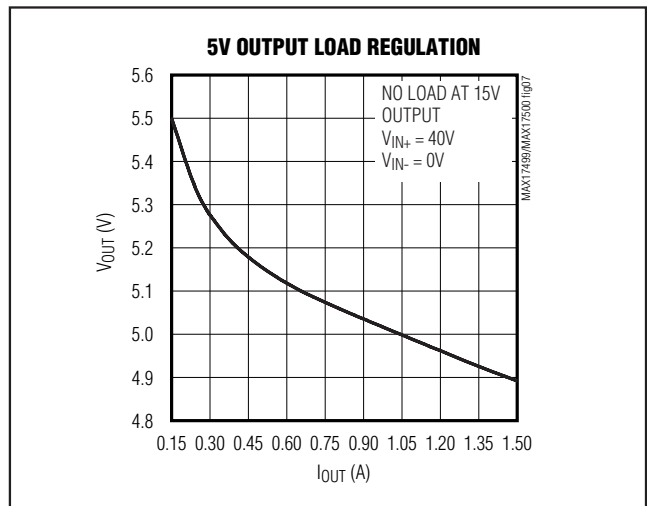

Figure 7. Output Voltage Regulation for the Circuit in Figure 6

Current-Mode PWM Controllers with Programmable Switching Frequency

MAX17499/MAX17500

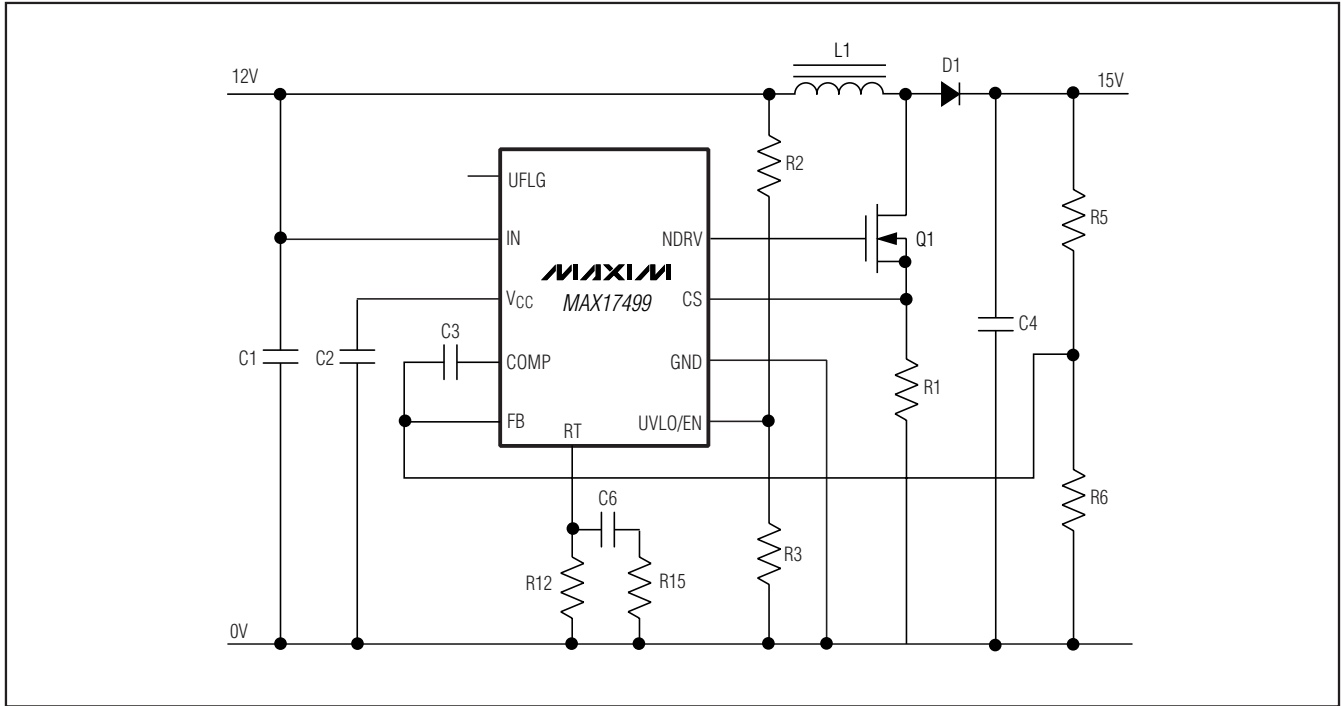

Figure 8. 12V to 15V Output Boost Regulator

Figure 8 shows the 12V to 15V output boost regulator.

Layout Recommendations

Typically, there are two sources of noise emission in a switching power supply: high di/dt loops and high dV/dt surfaces. For example, traces that carry the drain current often form high di/dt loops. Similarly, the heatsink of the MOSFET presents a dV/dt source; therefore, minimize the surface area of the heatsink as much as possible. Keep all PCB traces carrying switching

currents as short as possible to minimize current loops. Use a ground plane for best results. The pins of the μ MAX package are positioned to allow easy interfacing to the external MOSFET.

For universal AC input design, follow all applicable safety regulations. Offline power supplies may require UL, VDE, and other similar agency approvals. To avoid noise coupling of signals from RT to NDRV, route traces from RT away from NDRV.

Current-Mode PWM Controllers with Programmable Switching Frequency

Typical Application Circuit

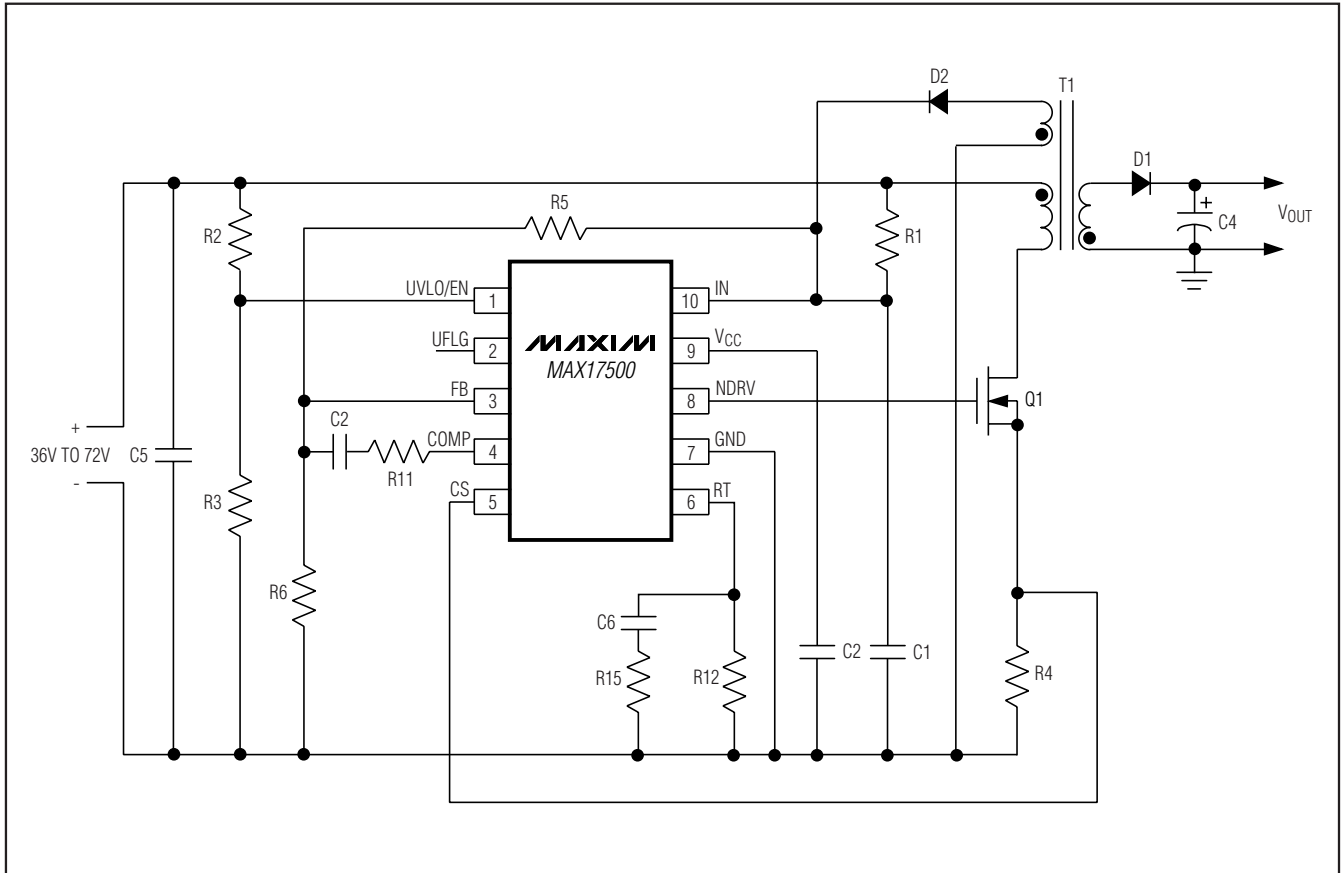

Current-Mode PWM Controllers with Programmable Switching Frequency

Functional Diagram

MAX17499/MAX17500

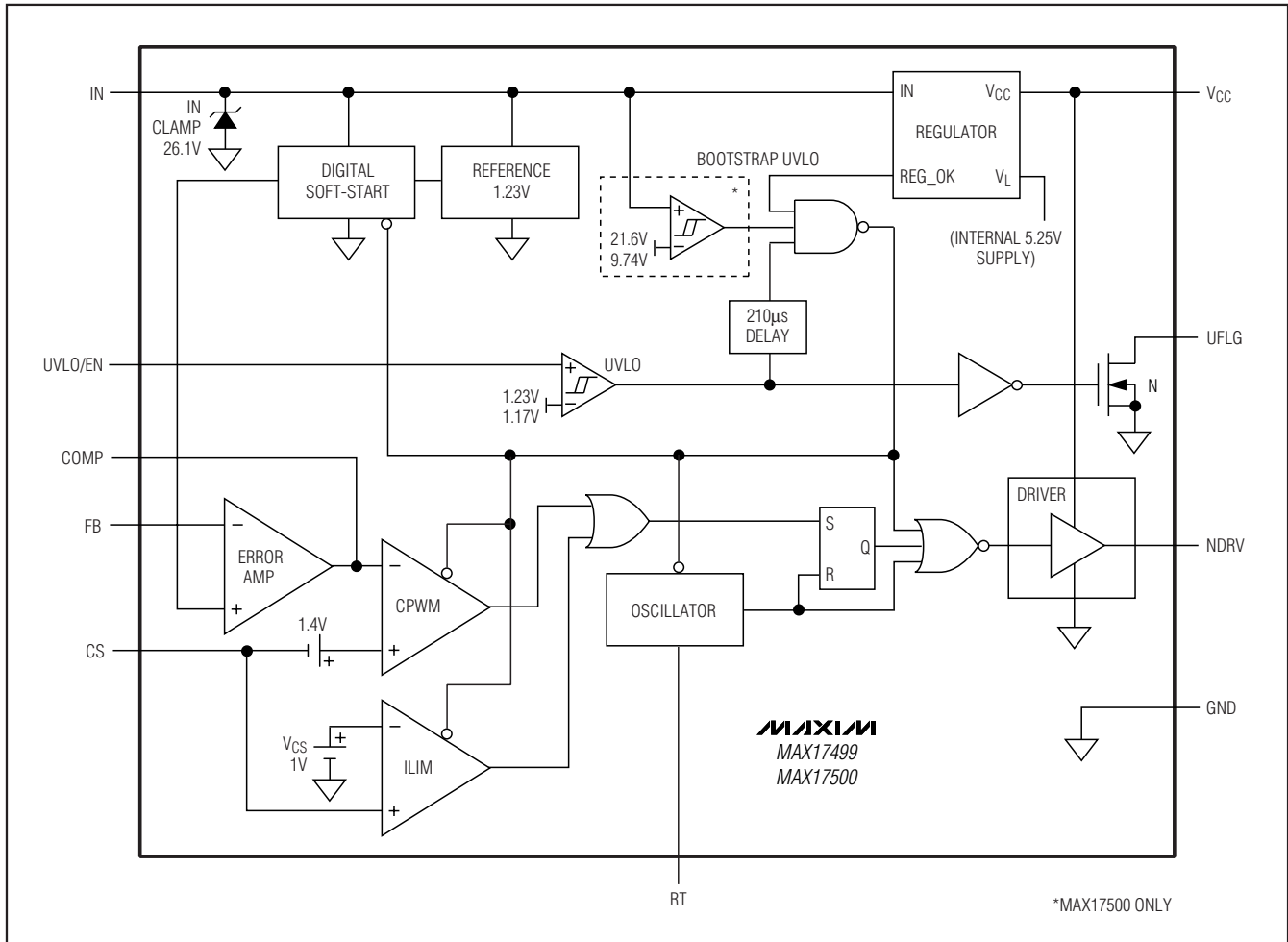

Selector Guide

PART*	BOOTSTRAP UVLO	STARTUP VOLTAGE (V)	MAX DUTY CYCLE (%)
MAX17499A	No	9.5	50
MAX17499B	No	9.5	75
MAX17500A	Yes	22	50
MAX17500B	Yes	22	75

*The MAX17499 does not have an internal bootstrap UVLO. The MAX17499 starts operation as long as V_{IN} is higher than 9.5V and UVLO/EN is higher than 1.23V.

Chip Information

PROCESS: BiCMOS

Package Information

For the latest package outline information and land patterns (footprints), go to www.maxim-ic.com/packages. Note that a "+", "#", or "-" in the package code indicates RoHS status only. Package drawings may show a different suffix character, but the drawing pertains to the package regardless of RoHS status.

PACKAGE TYPE	PACKAGE CODE	OUTLINE NO.	LAND PATTERN NO.
10 μ MAX	U10+2	21-0061	90-0330

Current-Mode PWM Controllers with Programmable Switching Frequency

Revision History

REVISION NUMBER	REVISION DATE	DESCRIPTION	PAGES CHANGED
0	9/10	Initial release	—
1	7/11	Changed operating temperature from -40°C to +85°C to -40°C to +125°C	1-4

Maxim cannot assume responsibility for use of any circuitry other than circuitry entirely embodied in a Maxim product. No circuit patent licenses are implied. Maxim reserves the right to change the circuitry and specifications without notice at any time.

18 _____ **Maxim Integrated Products, 120 San Gabriel Drive, Sunnyvale, CA 94086 408-737-7600**

Looking for pricing, stock, or lifecycle information?

Click below to explore more details on WIN SOURCE:

 [View MAX17499AAUB+](#) on WIN SOURCE

 [Maxim Integrated](#) Information

Optimize Your Supply Chain with WIN SOURCE Solutions

-  Global Sourcing Solution
-  Obsolete Management
-  Cost Control Management
-  Shortage Management
-  Alternative Solution
-  Excess Inventory Management