



**THE DATASHEET OF  
MAX845ESA+TG55**



EVALUATION KIT  
AVAILABLE

# MAXIM

## Isolated Transformer Driver for PCMCIA Applications

MAX845

### General Description

The MAX845 provides an isolated power supply small enough to fit in thin PCMCIA cards and space-sensitive applications. It drives a low-profile center-tapped transformer primary from a 5V or 3.3V DC power supply. The secondary can be wound to provide any isolated positive or negative voltage at powers up to 750mW.

The MAX845 consists of an oscillator followed by a toggle flip-flop. The flip-flop generates two 50% duty-cycle square waves, which are complementary at half the oscillator frequency (450kHz, min). These two signals drive the ground-referenced N-channel power switches. Internal circuitry ensures break-before-make action between the two switches.

A low-power shutdown disables both the switches and the oscillator, reducing power consumption. An evaluation kit (MAX845EVKIT-MM) is available to evaluate low-profile 5V 40mA and 5V 100mA applications.

### Applications

PCMCIA Modem Cards  
Isolated Data Acquisition  
Isolated Interface Power Supply  
Noise-Immunity Communications Interface  
Bridging Ground Differences  
Medical Equipment  
Process Control  
Low-Power LAN Networks

### Features

- ◆ Transformer Driver for Ultra-Thin 5V- $\mu$ s Transformers
- ◆ Isolated DC-to-DC Power Supply for PCMCIA Applications
- ◆ 450kHz Minimum Switching Frequency
- ◆ Ultra-Low Input Supply Current Ripple
- ◆ Single +5V or +3.3V Supply
- ◆ 5 $\mu$ W Low-Power Shutdown Mode
- ◆ 8-Pin SO and  $\mu$ MAX Packages
- ◆ Low Output Ripple Permits Miniature Output Capacitors

### Ordering Information

PART	TEMP. RANGE	PIN-PACKAGE
MAX845C/D	0°C to +70°C	Dice*
MAX845ESA	-40°C to +85°C	8 SO
MAX845EUA	-40°C to +85°C	8 $\mu$ MAX

\*Contact factory for dice specifications.

### Typical Operating Circuit

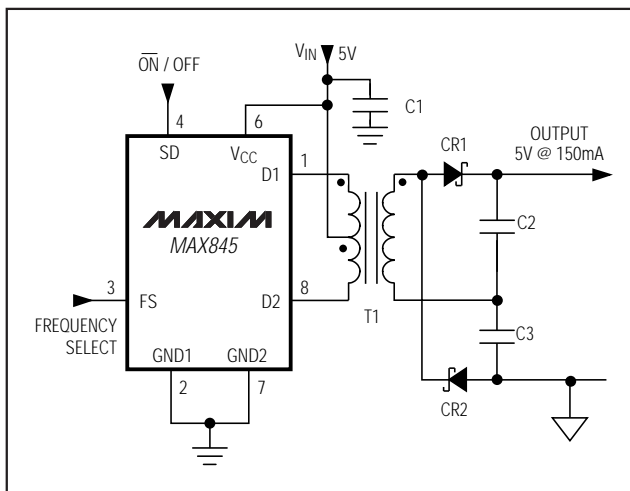

### Pin Configuration

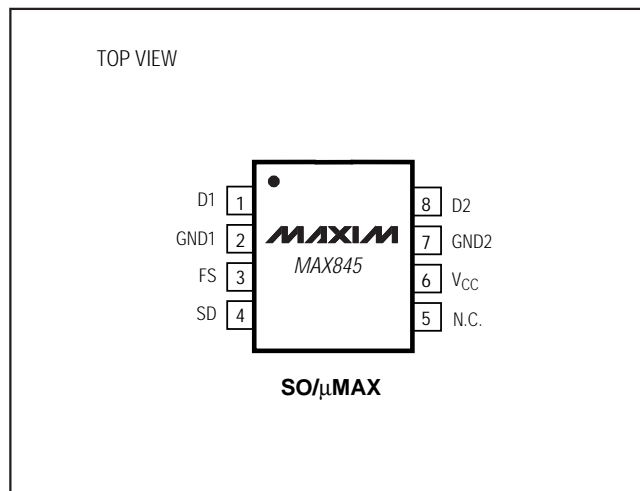

MAXIM

Maxim Integrated Products 1

For free samples & the latest literature: <http://www.maxim-ic.com>, or phone 1-800-998-8800.  
For small orders, phone 408-737-7600 ext. 3468.

# Isolated Transformer Driver for PCMCIA Applications

## ABSOLUTE MAXIMUM RATINGS

Supply Voltage ( $V_{CC}$ )	-0.3V to +7V	Operating Temperature Range	-40°C to +85°C
Control Input Voltage (SD, FS)	-0.3V to ( $V_{CC} + 0.3V$ )	Storage Temperature Range	-65°C to +160°C
Peak Output Switch Current (D1, D2)	1A	Junction Temperature	+150°C
Output Switch Voltage (D1, D2)	12V	Lead Temperature (soldering, 10sec)	+300°C
Average Output Switch Current (D1, D2)	200mA		
Continuous Power Dissipation ( $T_A = +70^\circ\text{C}$ )			
SO (derate 5.88mW/°C above +70°C)	471mW		
$\mu\text{MAX}$ (derate 4.10mW/°C above +70°C)	330mW		

Stresses beyond those listed under "Absolute Maximum Ratings" may cause permanent damage to the device. These are stress ratings only, and functional operation of the device at these or any other conditions beyond those indicated in the operational sections of the specifications is not implied. Exposure to absolute maximum rating conditions for extended periods may affect device reliability.

## ELECTRICAL CHARACTERISTICS

( $V_{CC} = 5V \pm 10\%$ ,  $T_A = T_{MIN}$  to  $T_{MAX}$ , unless otherwise noted. Typical values are at  $T_A = +25^\circ\text{C}$ .)

PARAMETER	CONDITIONS	MIN	TYP	MAX	UNITS
Switch On-Resistance	D1, D2: 100mA		1.5	4.0	$\Omega$
Switch Frequency	FS = $V_{CC} = 4.5V$	450	675	900	kHz
	FS = $V_{CC} = 5.5V$	550	860	1100	
	FS = 0V, $V_{CC} = 4.5V$		500		
	FS = 0V, $V_{CC} = 5.5V$		575		
Operating Supply Current (Note 1)	No load, SD = 0V, FS = $V_{CC}$		1.1	5.0	mA
Shutdown Supply Current (Note 2)	SD = $V_{CC}$		0.4		$\mu\text{A}$
Shutdown Input Threshold	High	2.4			V
	Low			0.8	
Shutdown Input Leakage Current			10		pA
FS Input Threshold	High	2.4			V
	Low			0.8	
FS Input Current	FS = 0V			50	$\mu\text{A}$
	FS = $V_{CC}$		10		
Minimum Start-Up Voltage		2.5	2.2		V

**Note 1:** Operating supply current is the current used by the MAX845 only. Load current is not included.

**Note 2:** Shutdown supply current includes output switch leakage currents.

# Isolated Transformer Driver for PCMCIA Applications

## Typical Operating Characteristics

(Typical Operating Circuit,  $V_{IN} = 5V$ ,  $C1 = 0.1\mu F$ ,  $C2 = C3 = 0.33\mu F$ ,  $T1 = \text{Halo TGM-010P3}$ ,  $CR1 = CR2 = \text{MBR0520}$ ,  $FS = V_{CC}$ ,  $T_A = +25^\circ C$ , unless otherwise noted.)

MAX845

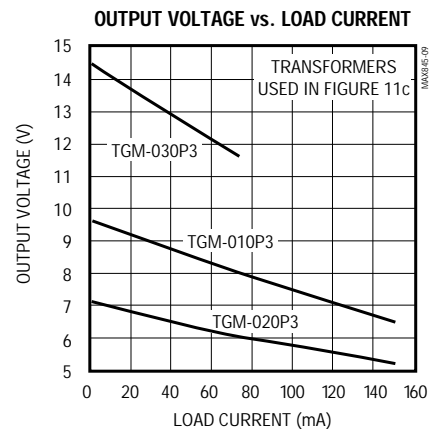
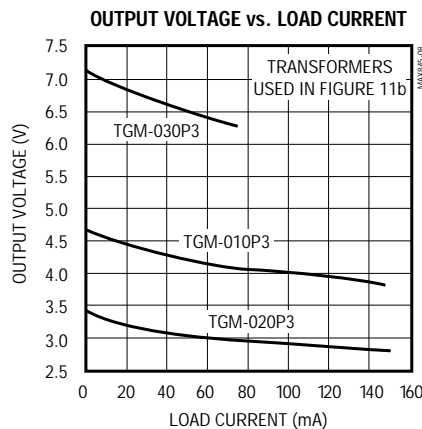
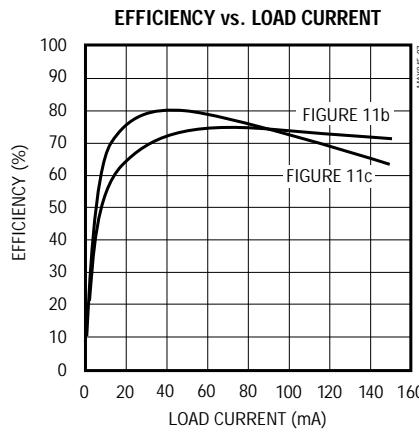
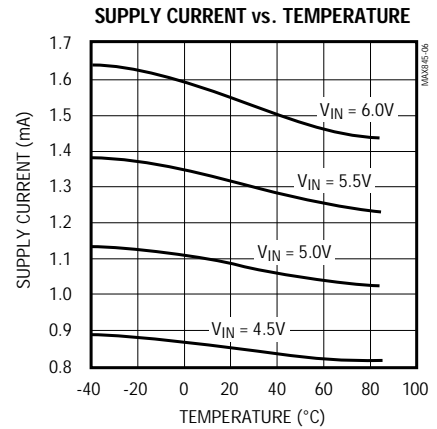
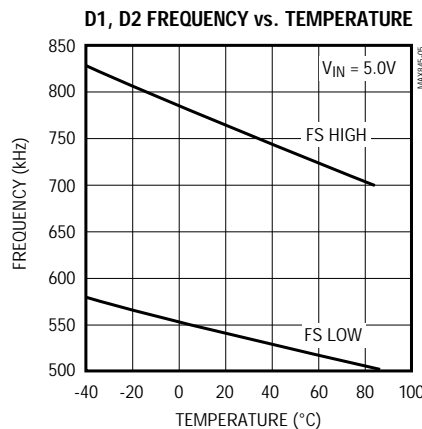
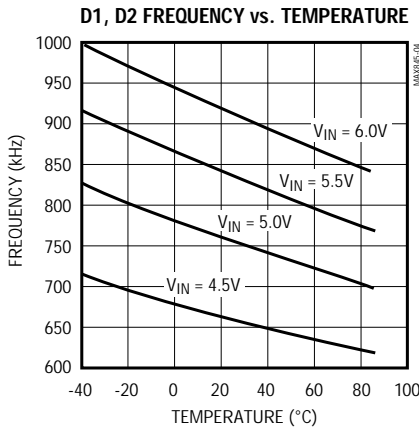
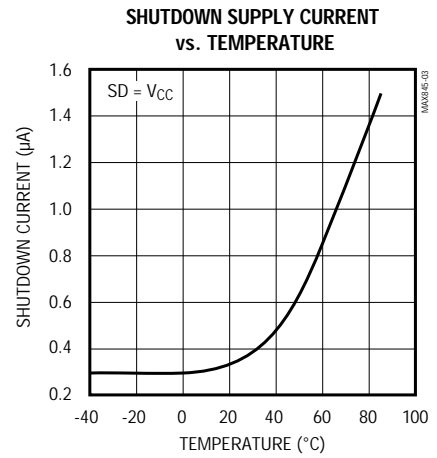
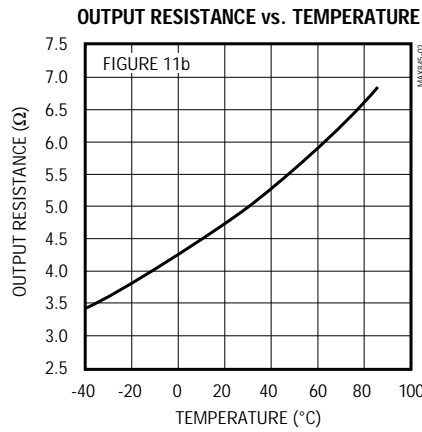
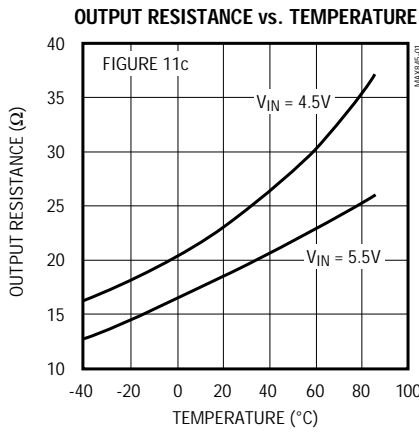

# Isolated Transformer Driver for PCMCIA Applications

## Typical Operating Characteristics (continued)

(Typical Operating Circuit,  $V_{IN} = 5V$ ,  $C1 = 0.1\mu F$ ,  $C2 = C3 = 0.33\mu F$ ,  $T1 = \text{Halo TGM-010P3}$ ,  $CR1 = CR2 = \text{MBR0520}$ ,  $FS = V_{CC}$ ,  $T_A = +25^\circ C$ , unless otherwise noted.)

**SWITCHING WAVEFORMS (TWO CYCLES)**

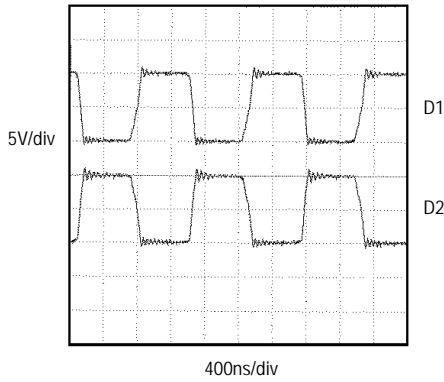

**SWITCHING WAVEFORM (BREAK-BEFORE-MAKE)**

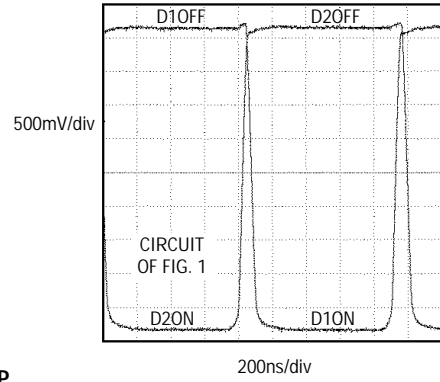

**TIME FROM SHUTDOWN TO POWER-UP**

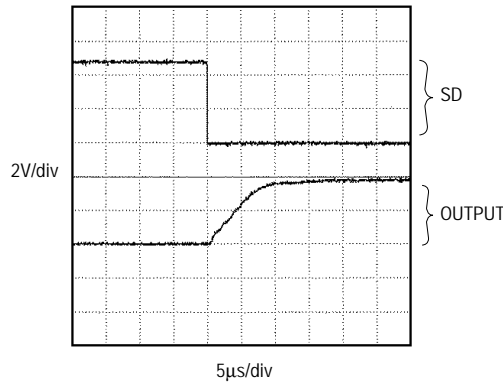

## Pin Description

PIN	NAME	FUNCTION
1	D1	Open Drain of N-Channel Transformer Drive 1
2	GND1	Ground. Connect both GND1 and GND2 to ground.
3	FS	Frequency Select (internal pull-up). If $FS = V_{CC}$ or open, switch frequency = 725kHz; if $FS = 0V$ , switch frequency = 535kHz.
4	SD	Shutdown. Ground for normal operation, connect to $V_{CC}$ for shutdown.
5	N.C.	No Connect. Not internally connected.
6	$V_{CC}$	+5V Supply Voltage
7	GND2	Ground. Connect both GND1 and GND2 to ground.
8	D2	Open Drain of N-Channel Transformer Drive 2

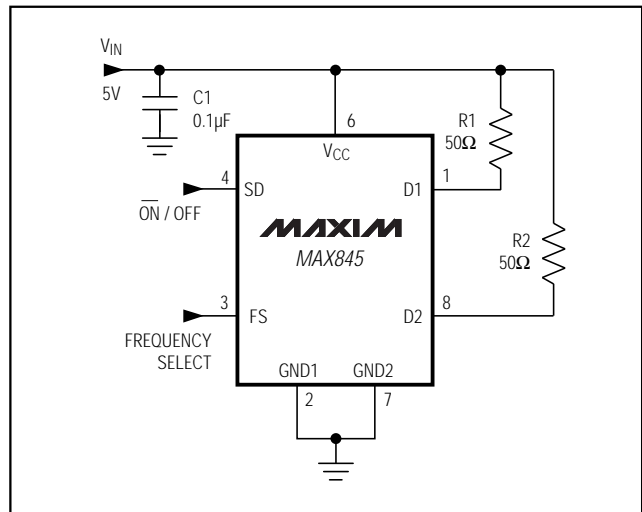

Figure 1. Test Circuit

# Isolated Transformer Driver for PCMCIA Applications

MAX845

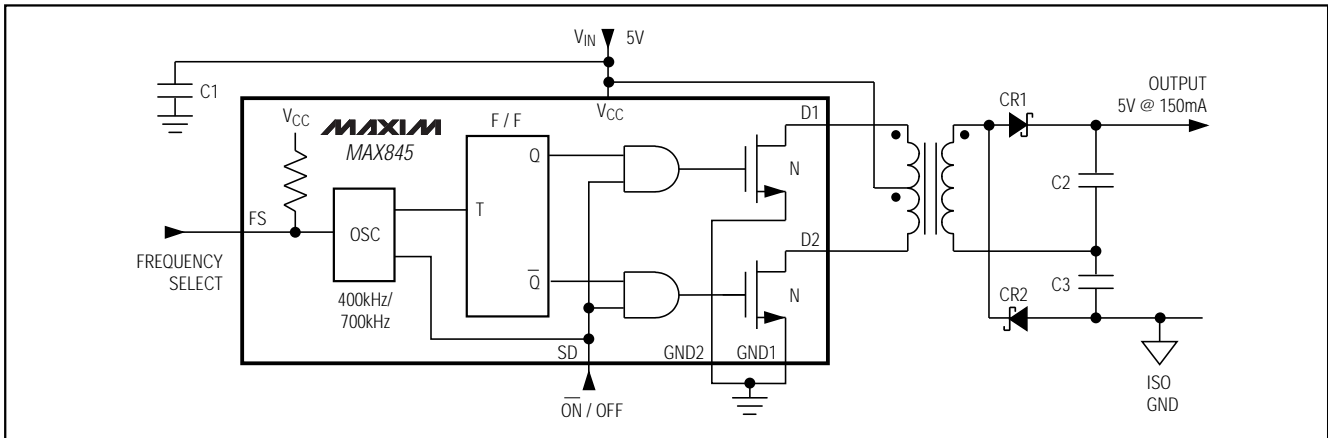

Figure 2. Detailed Block Diagram

## Detailed Description

The MAX845 is a transformer driver specifically designed to provide isolated power for PCMCIA and other height- and/or space-sensitive applications. It drives a center-tapped transformer primary from a 5V or 3.3V DC power supply. The secondary can be wound to provide any isolated DC voltage needed at power levels up to 750mW.

The 450kHz minimum switching frequency allows the use of very thin transformers, making the MAX845 ideal for PCMCIA and other space-limited applications. The MAX845 is designed to drive a single transformer less than 0.09 inches (2.3mm) in height, including package. Further reduction down to 0.050 inches (1.27mm) can be achieved using a transformer without a package.

The MAX845 consists of an RC oscillator driving a pair of N-channel power switches. The oscillator runs at double the output frequency, driving a toggle flip-flop to ensure 50% duty cycle to each of the switches. Internal circuitry ensures break-before-make action between the two switches.

A low-current shutdown mode disables all internal circuitry, including the oscillator and both power switches. Drive the shutdown pin (SD) high to shut down the part; drive SD low for normal operation. The SD pin has no internal default condition and must not be allowed to float.

Most MAX845 applications will operate at high frequencies. The frequency-select pin (FS) is pulled high or left open (FS is internally pulled up to V<sub>CC</sub>) to operate at a minimum of 450kHz. Pulling FS low selects the low-frequency state.

## Theory of Operation

Figure 2 shows the MAX845 driving both a TGM-010P3 transformer with a center-tapped primary, and a secondary with a voltage-doubler rectifier topology. All of the transformers driven by the MAX845 must have a center tap with V<sub>IN</sub> applied. Whenever one of the MAX845 outputs (D1 or D2) goes low, the other goes to approximately double the supply voltage. A voltage is induced in the secondary and the rectifier diodes steer the currents into the appropriate output capacitor. On alternate half cycles, each capacitor is charged. The output voltage is the sum of the voltages from each output capacitor. This topology yields the simplest and smallest transformer because the least number of secondary turns is required for a given voltage.

## Applications Information

With the MAX845 transformer driver, designers have the advantages of push/pull converter topology in space-sensitive applications. The push/pull DC-DC converter topology allows isolated multiple outputs, step-up/step-down or inverted outputs, easier filtering on the input and the output, and lower overall noise.

### Isolated Power for PCMCIA Applications

Medical instrumentation, modems, and LAN-interface cards often require isolated power supplies. One of the best switching-regulator topologies for this application is the push/pull forward-converting DC-DC power supply shown in Figures 3 and 4. Because the transformer works in the forward mode (rather than the flyback mode), its core does not store energy and, therefore, can be small. Input and output capacitors can be small because of the high-frequency and continuous-current waveforms.

# Isolated Transformer Driver for PCMCIA Applications

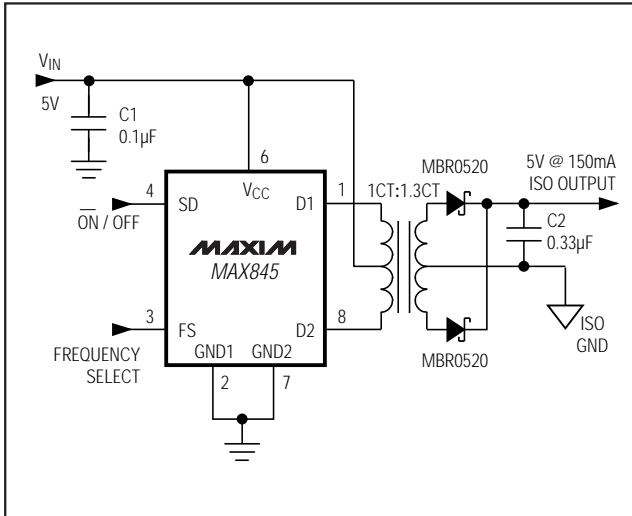

Figure 3. 5V to Isolated 5V Application Circuit

The MAX845 is a versatile transformer driver, capable of driving a center-tapped transformer primary from a 5V or 3.3V DC power supply (Figures 3 and 4). The secondary can be wound to provide any isolated voltage needed at power levels up to 750mW with a 5V supply or up to 500mW with a 3.3V supply. Figure 3 shows a typical 5V to isolated 5V application circuit that delivers up to 150mA of isolated 5V power.

### 3.3V Supply

Any of the application circuits shown may be converted to 3.3V operation by changing the turns ratio of the transformer and operating the MAX845 from a boost supply, as shown in Figure 4. In normal operation, whenever one of the MAX845 outputs goes low, the other goes to approximately double the supply voltage. Since the circuit is symmetrical, the two outputs can be combined with diodes, lightly filtered, then used to power the MAX845, and possibly other light loads as well.

The diodes on the primary side may be any fast-switching small-signal diodes, such as the 1N914, 1N4148, or CMPD2838. The value of the primary filter capacitor is not critical and can be very small, since it only needs to supply current to the MAX845 during the break-before-make interval.

The transformer could be any of the same ones used for 5V operation, but for optimum performance it should have fewer primary turns, as the ET product required is now only 3.3V-µs. For a given power level, the currents

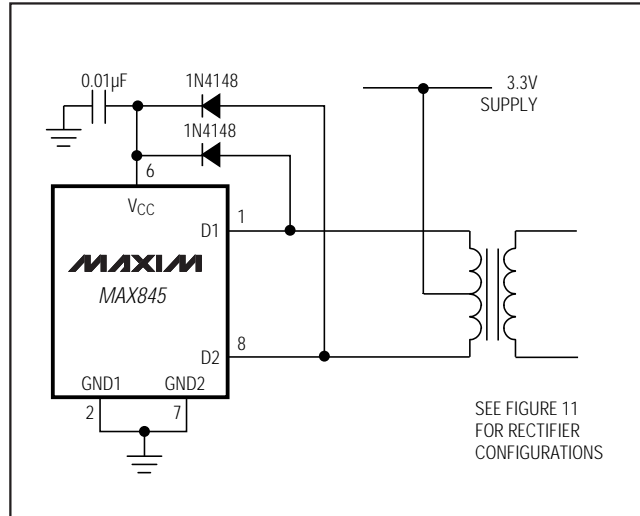

Figure 4. 3.3V Input to Isolated Output Application Circuit

will be higher at 3.3V, so transformer winding resistance will be more critical and efficiencies will be lower. The MAX845 output current must still be limited to 200mA (see *Absolute Maximum Ratings*), so the available output power will be less than with a 5V power source.

### Low-Noise Power Supply

The MAX845 topology is inherently low noise, in that either one or the other of the two power devices is on at any given time. By alternating between two identical states with one side on and the other off, the input current is nearly constant and secondary output power is available at all times. There is an intentional break-before-make action to prevent any possibility of both power switches conducting at the same time. During this 100ns non-overlap interval, the input current goes to zero. This adds a small high-frequency component to the input current waveform. This ripple current can easily be absorbed by a small input bypass capacitor (0.33µF) from VCC to ground. Figure 5 shows a low-noise bias supply using the MAX845 transformer driver.

When using the two-diode push-pull (Figure 11a) rectifier or the four-diode bridge (Figure 11b), the output voltage tends to be more constant than in most alternative topologies. As described above, the circuit alternates between two identical states that both provide power to the load. The only part of the cycle that produces output ripple is the 100ns non-overlap interval, which can easily be filtered by a small ceramic output capacitor (0.33µF).

# Isolated Transformer Driver for PCMCIA Applications

MAX845

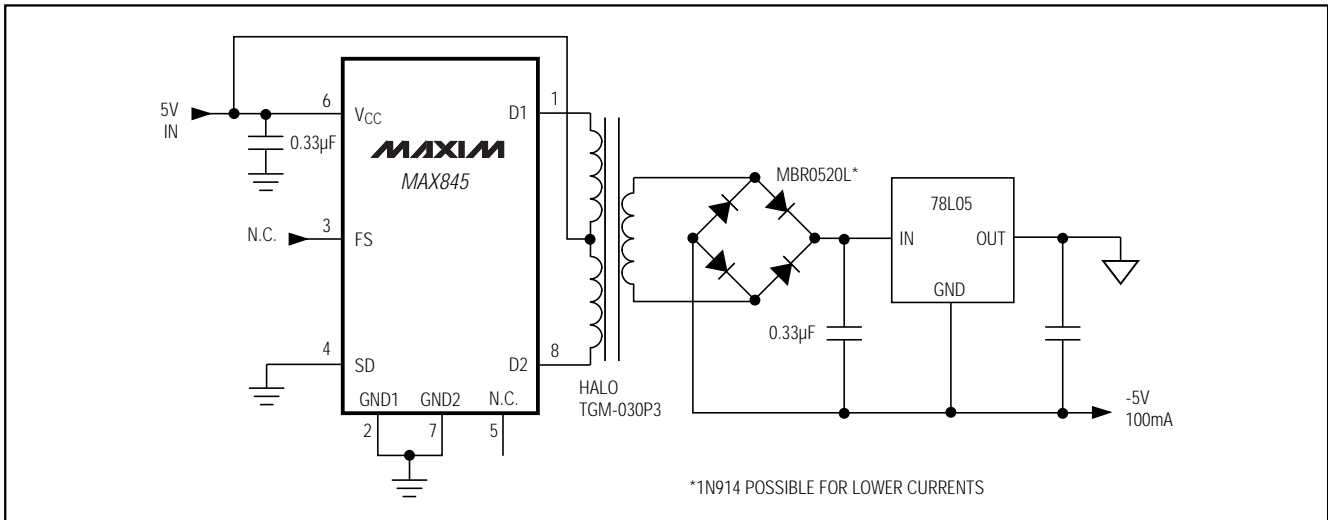

Figure 5. Low-Noise Supply

## Isolated Data Conversion

Almost any serial-interface device is a candidate for operation across an isolation barrier; Figure 6 illustrates one example. The MAX176 analog-to-digital converter (ADC) operates from +5V and -12V supplies, provided by the multiple-tapped secondary and linear regulators. This circuit easily supplies several hundred milliwatts of additional isolated power for signal conditioning, multiplexing, or sensors. A +12V supply can be generated by adding two more diodes from the ends of the secondary, and a -5V supply can be generated by connecting additional diodes to the 1/4 and 3/4 tap points on the secondary. The MAX845 supplies sufficient power for almost any Maxim ADC.

## Telephone-Subscriber-Line Power Supply

The standard telephone system is placed in the "off hook" state by placing a load on the line to signal the central office that service is requested. Normally, most of this power is wasted in a load resistor, but some systems can benefit from utilizing this free power. Figure 7 shows one way to transform the wasted telephone power to an isolated, regulated 5V at currents up to 50mA.

Because the telephone line is a high-impedance source, there can be a start-up problem with any DC-to-DC converter; when the line voltage is low during start-up, the frequency can be too low for the transformer, causing it to saturate. This excess saturation current can keep the voltage from climbing to normal operating levels. Thus the purpose of Q1, Q2, and the associated resistors is to ensure that the MAX845

remains in the shutdown mode until the voltage is high enough to allow proper operation.

## Isolated 4mA to 20mA Analog Interface

The 4mA to 20mA current loop is widely used in the process-control industry for transducer and actuator control signals. These signals are commonly referred to a distant ground that may be at a considerably higher voltage with respect to the local ground. The circuit in Figure 8 generates an isolated 4mA to 20mA current from a 5V supply.

## Isolated RS-485 Data Interface

The MAX845 power-supply transformer driver also provides isolated power for RS-485 data-interface applications. The application circuit of Figure 9 combines the MAX845 with a low-dropout linear regulator, a transformer, several high-speed optocouplers, and a Maxim RS-485 interface device.

## Isolated RS-232 Data Interface

The MAX845 is ideal for isolated RS-232 data-interface applications requiring more than four transceivers. Its 750mW output power capability enables it to drive 10 transceivers simultaneously. Figure 10 shows the typical application circuit for a complete 120kbps isolated RS-232 data interface. This figure also shows how the Sharp PC417 optocouplers can be replaced by the lower-cost Quality Technologies 4N25 devices to achieve data transfer rates up to 19.2kbps.



# Isolated Transformer Driver for PCMCIA Applications

MAX845

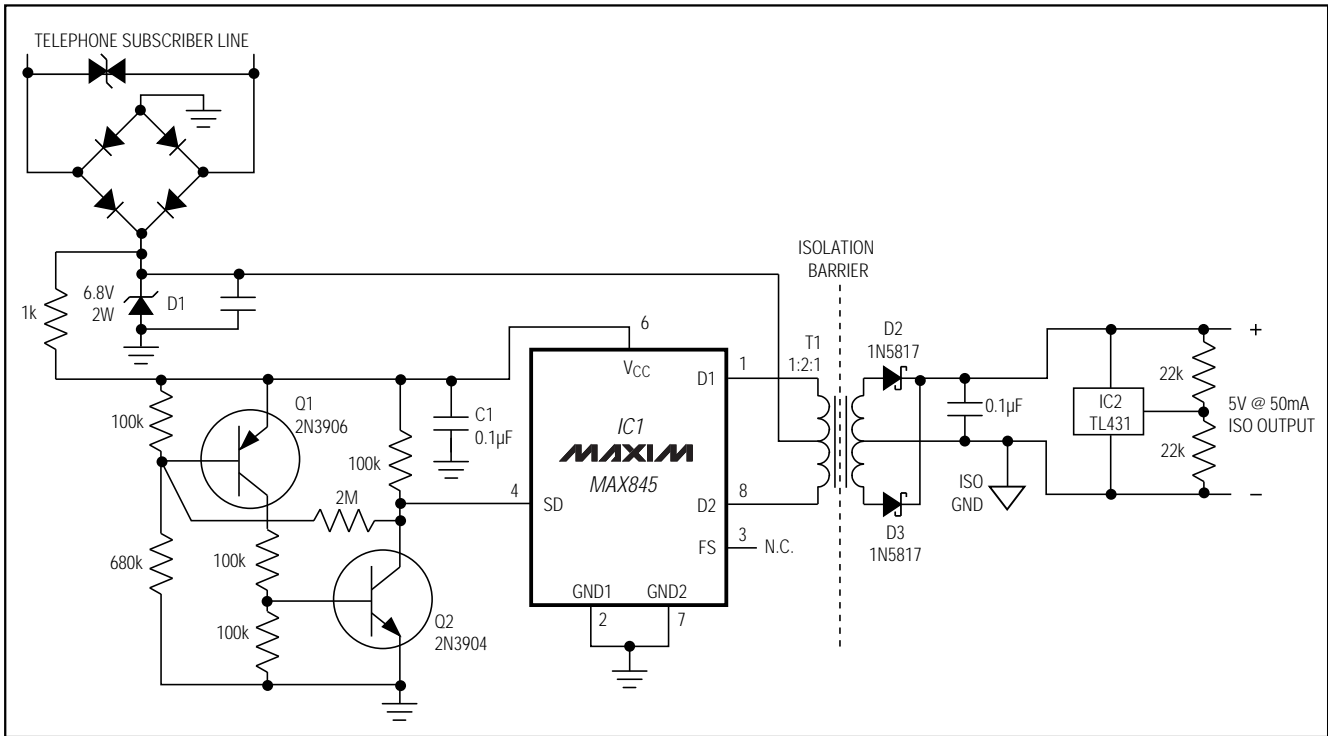

Figure 7. 5V from Telephone-Subscriber Line

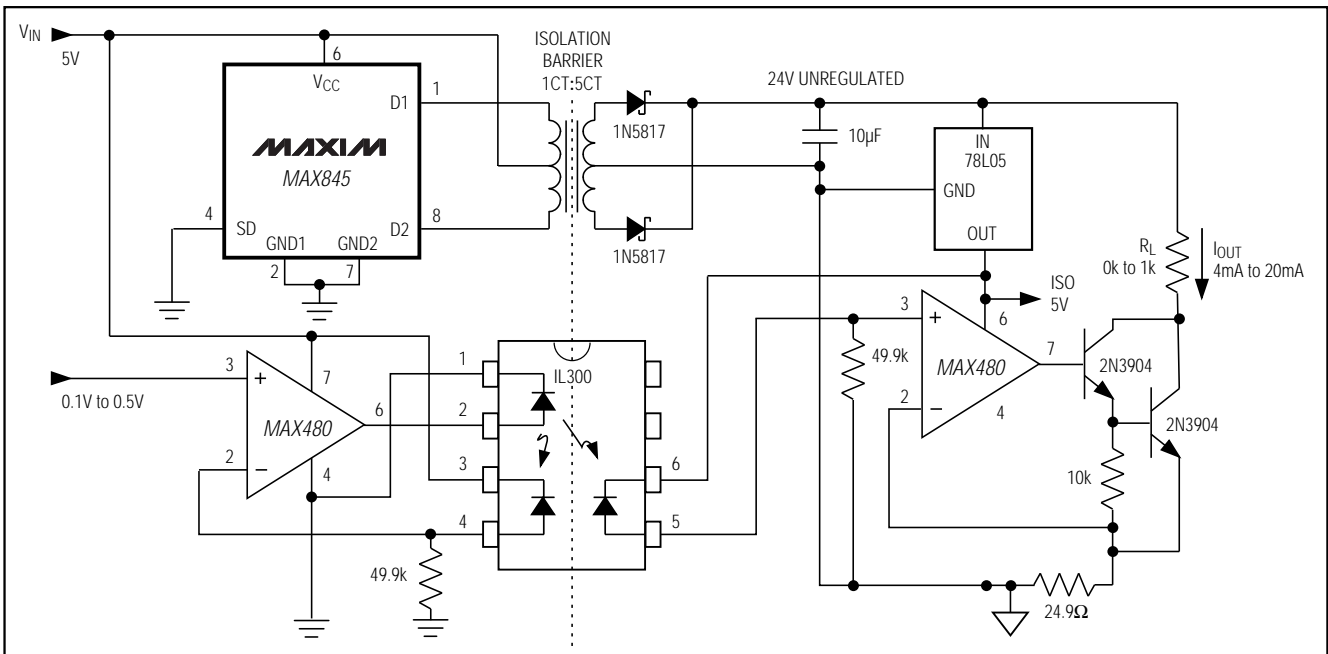

Figure 8. Typical 4mA/20mA Application Circuit



# Isolated Transformer Driver for PCMCIA Applications

MAX845

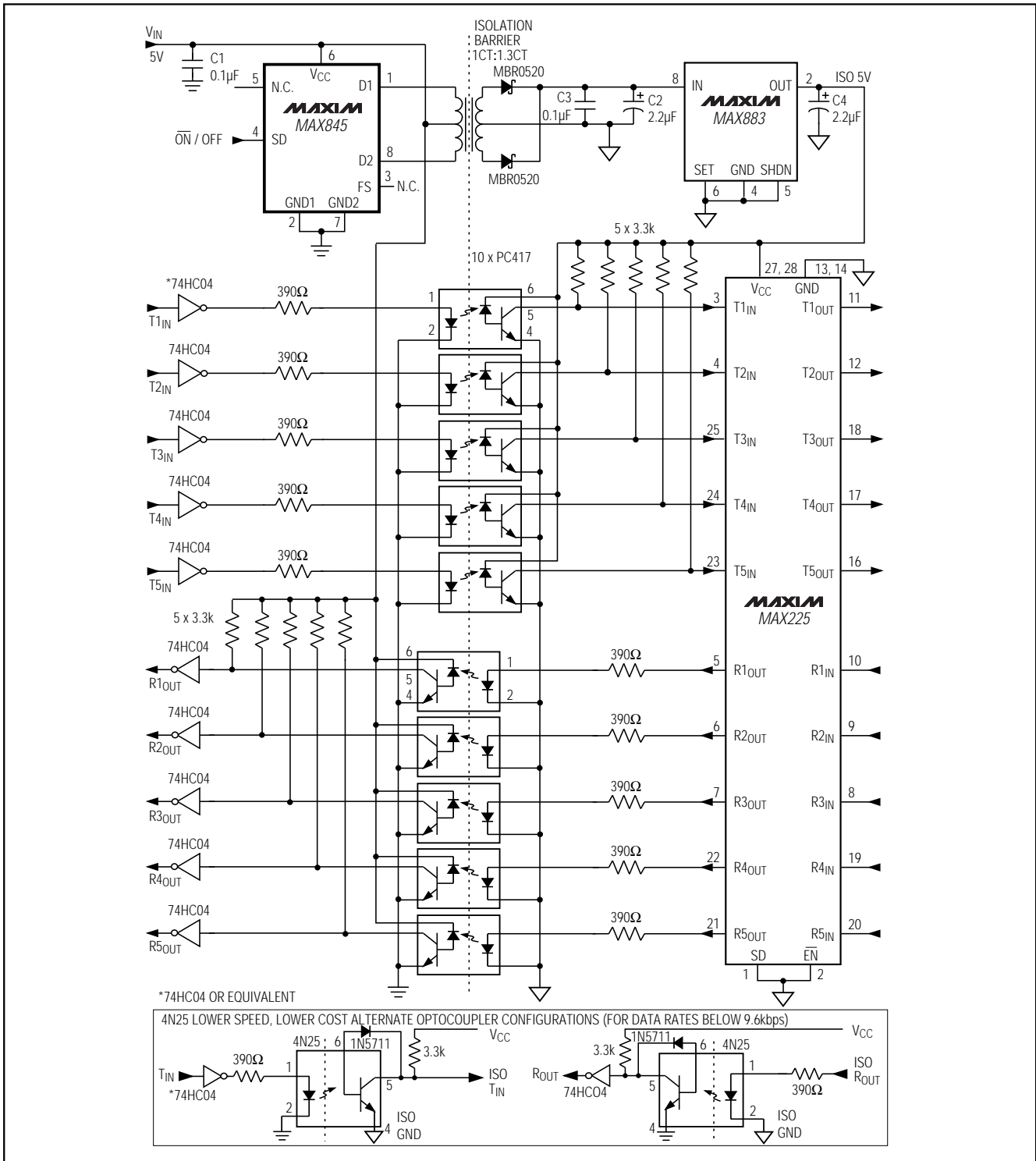

Figure 10. Typical RS-232 Application Circuit

# Isolated Transformer Driver for PCMCIA Applications

## Component Selection

### Transformer

The MAX845 drives any transformer that has a center-tapped primary and a saturation rating of at least 5V- $\mu$ s (ET product) per side. The oscillator frequency varies linearly with  $V_{CC}$ . The transformer is most vulnerable to saturation at the minimum frequency, because the switches are on for the longest period. At  $V_{CC} = 4.5V$ , the transformer must withstand at least:

$$4.5V \times \frac{1}{450\text{kHz min}} \times \frac{1}{2} = 5V\text{-}\mu\text{s}$$

And at  $V_{CC} = 5.5V$ , the transformer must withstand at least:

$$5.5V \times \frac{1}{550\text{kHz min}} \times \frac{1}{2} = 5V\text{-}\mu\text{s}$$

Thus, the required ET product is constant over the entire 5V  $\pm$ 10% range.

Select either a toroid or a gapped core. Although some applications will require custom transformers, many can use standard transformer designs, such as those listed in Table 1. Some of these manufacturers have standard products designed for the MAX845, while some have standard products that can be adapted for specific customer requirements. Table 1 also lists some suppliers of suitable magnetic cores.

**Table 1. Transformer and Transformer-Core Suppliers**

TRANSFORMERS	TRANSFORMER CORES
Halo Electronics Phone: (415) 969-7313 FAX: (415) 367-7158 Ask for MAX845 Transformer	Magnetics Inc. Phone: (412) 282-8282 FAX: (412) 282-6955
Coilcraft Phone: (708) 639-6400 FAX: (708) 639-1469 Ask for MAX845 Transformer	Fair-Rite Products Phone: (914) 895-2055 FAX: (914) 895-2629
BH Electronics Phone: (612) 894-9590 FAX: (612) 894-9380 Ask for MAX845 Transformer	Philips Components Phone: (401) 762-3800 FAX: (401) 762-3805, ext. 324
Sumida USA Phone: (708) 956-0666 FAX: (708) 956-0702	MMG (Magnetic Materials Group) Phone: (201) 345-8900 FAX: (201) 345-1172
	Amidon Associates Phone: (714) 850-4660 FAX: (714) 850-1163

An ungapped toroid core must never be allowed to saturate. An empirical way to measure a toroid's ET product is to wind 20 turns on the bare core and observe the current waveform on an oscilloscope while driving the winding with a function generator. Generate a 50% duty-cycle square wave at a test frequency of 500kHz, with no DC offset. Gradually increase the driving voltage until the waveform suddenly begins to draw more current. At this point, the core is saturating, so reduce the driving voltage until the core just barely stops saturating. The ET product indicated is simply the maximum voltage that can be applied without saturation, multiplied by 1 $\mu$ s (the time of half of the period of the input signal). Because the ET product varies linearly with the number of turns, this test winding can be scaled up or down to act as a suitable primary for that particular core.

A gapped core, such as a bobbin or drum core, is not limited by ET product, but rather by inductance and winding resistance. The primary inductance must be high enough to prevent excessive current flow under light-load conditions, yet low enough that it can be wound on the core. Good results can be achieved by using a primary inductance between 50 $\mu$ H and 200 $\mu$ H. Calculate the number of turns required by using the manufacturer's  $A_L$  (inductance per turn squared) value, or measure a test winding with an inductance meter. Inductance varies with the square of the number of turns.

While most MAX845 applications will use a toroid transformer for highest efficiency and lowest EMI, there may be applications that can utilize less expensive transformers, such as E, I, or U-shaped cores, magnetic bobbins, or etched windings on a printed circuit board. Table 1 lists some transformer and core suppliers who can assist with your magnetics design.

The secondary or secondaries can be scaled to produce whatever output is required for the application at hand, taking into account the rectifier topology to be used and the forward voltage loss of the diodes selected.

### Step-by-Step Transformer Design Procedure

Before starting the design, determine the minimum and maximum output voltage requirement, the minimum and maximum load current, the physical size constraints, and the cost budget.

- 1) Select an appropriate core shape and material from core vendors' data sheets; trade-off EMI vs. space and cost. Since the MAX845's output waveform is a square wave, it is rich in harmonics, so choose a material with low losses at up to several MHz.

# Isolated Transformer Driver for PCMCIA Applications

- 2) Use a test winding to measure ET product (if using an ungapped toroid) and/or  $A_L$  value for the core.
- 3) Determine the number of turns required for the primary winding. For an ungapped toroid, ET product from center-tap to D1 must be at least  $5V\text{-}\mu\text{s}$ . Other core types must have sufficient inductance to limit D1 and D2 output current under minimum load conditions, and must not be allowed to saturate.
- 4) Select a rectifier topology based on performance requirements (ripple vs. loss, and space required for secondary winding). Refer to Table 2, Rectifier Topology Trade-Offs.
- 5) Work backward from  $V_{OUT}$  requirements to determine the secondary to primary turns ratio. Include losses in the rectifier diodes, and estimate resistive losses in the windings. For load currents exceeding 150mA, use a voltage step-down transformer to step up the output current from the MAX845. Do not exceed the MAX845's absolute maximum output current rating (200mA).
- 6) Wind the transformer with the largest diameter wire that will fit the winding area. Select a wire gauge to fill the winding aperture as much as possible. Larger diameter wire has lower resistance per unit length. Doubling the wire diameter reduces resistive losses by a factor of four.

Bobbin or drum cores suffer from low coupling between windings. This usually requires bifilar winding for the two halves of the primary.

Due to the inherent complexity of magnetic circuit design, it will be necessary to build a prototype and reiterate the design. If necessary, adjust the design by altering the number of primary or secondary turns, or the wire gauge. If using a different core material or geometry, evaluate its ET product or  $A_L$  as described above.

### Rectifier Topology

Figure 11 shows various rectifier topologies. Refer to Table 2 for selection criteria. The turns ratio of the transformer must be set to provide the minimum required output voltage at the maximum anticipated load, with the minimum expected input voltage. In addition, the calculations should allow for worst-case losses in the rectifiers. Since the turns ratio determined in this manner will ordinarily produce a much higher voltage at the secondary under conditions of high input voltage and/or light loading, be careful to prevent an overvoltage condition from occurring (see the Output Voltage vs. Load Current graph in the *Typical Operating Characteristics*).

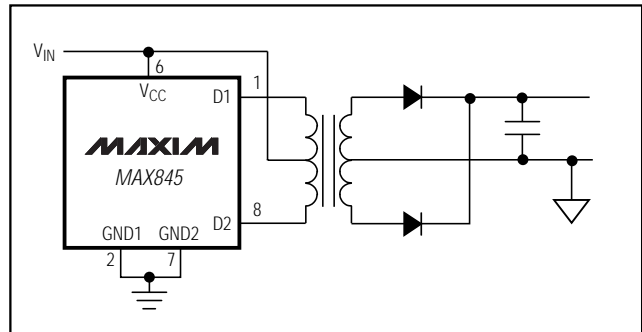

Figure 11a. 2-Diode Push-Pull

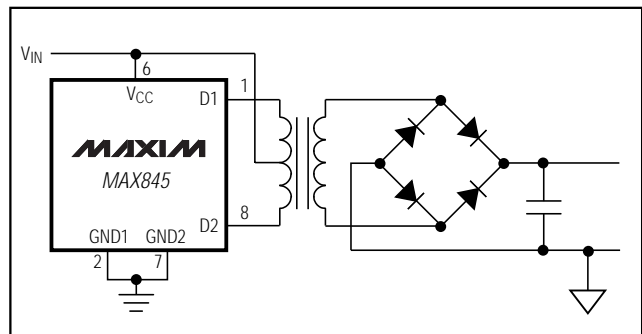

Figure 11b. 4-Diode Bridge

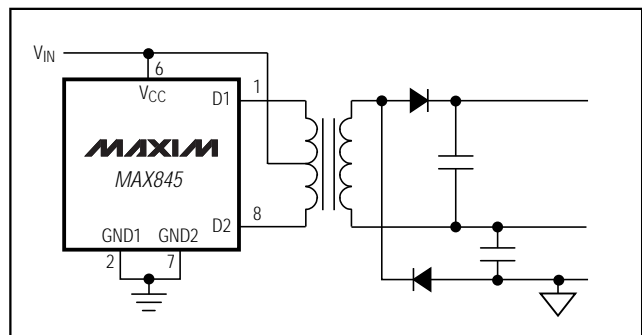

Figure 11c. Voltage Doubler

### Diodes

Use fast-switching diode rectifiers. Ordinary silicon signal diodes like the 1N914 or 1N4148 may be used for low output current levels (less than 50mA), but Schottky diodes have a lower forward voltage drop and should be used for higher-current applications. Central Semiconductor has low-current Schottky diodes as duals in SOT-23 packages (CMPSH-3 series). The Nihon SB05W05C is a common-cathode dual in a SOT-23; it works well in the two-diode full-wave configuration. The Motorola MBR0520 is an excellent choice for all configurations.

# Isolated Transformer Driver for PCMCIA Applications

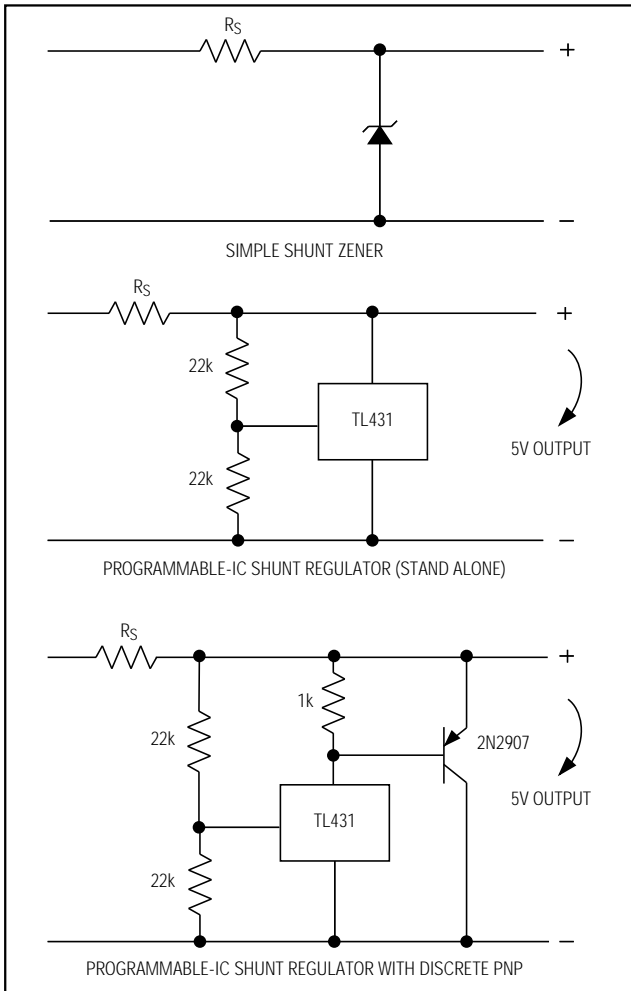

Figure 12. Shunt-Regulator Circuits

## Output Regulator

Since the output voltage is not regulated against changes in the input voltage or load current, an output voltage regulator may be needed. A series linear regulator gives good performance and reasonably good efficiency at low cost. A shunt regulator costs less, occupies less space, and gives adequate performance for some applications.

Series regulators such as the MAX666, MAX667, MAX882/MAX883/MAX884, or MAX603/MAX604 simplify designs. Just select one with the desired output voltage and current capability, and connect it.

The simplest voltage regulator is the shunt zener shown in Figure 12. The series resistor ( $R_S$ ) value should be as high as possible to still deliver the maximum expected load current with minimum input voltage. Be sure that no ratings are exceeded at maximum input voltage and minimum load current conditions; under such conditions, the zener diode may have to dissipate much more power than the load. Alternatively, start with the maximum allowable zener dissipation and select the series resistor under light-load, high-line conditions. Then verify that there is sufficient output current available with worst-case low input voltage.

For better regulation than the simple shunt zener, consider a shunt regulator IC such as the TL431. This device behaves like a zener diode whose voltage can be programmed by a resistor ratio. It can be used as a stand-alone device or can be boosted above its 150mA maximum rating without compromising its accuracy by adding a discrete PNP transistor, as shown in Figure 12.

The input power of a shunt regulator is nearly independent of load, so efficiency at light loads tends to be worse than it would be with a series regulator.

## Output Filter Capacitor

Ceramic capacitors can be used as output capacitors because of the lower level of output ripple current. In applications where output ripple is not critical, a 0.33 $\mu$ F chip or ceramic capacitor is normally sufficient. Refer to Table 3 for suggested capacitor suppliers.

In applications sensitive to output-ripple noise, the output filter capacitor ( $C_2$ ) should have a low equivalent series resistance (ESR) and a low equivalent series inductance (ESL), and its capacitance should remain fairly constant over temperature.

Sprague 595D surface-mount solid tantalum capacitors and Sanyo OS-CON through-hole capacitors are recommended, if space allows, due to their extremely low ESR. Capacitor ESR usually rises at low temperatures, but OS-CON capacitors provide very low ESR below 0°C.

## Input Bypass Capacitor

The input bypass capacitor ( $C_1$ ) is not critical. Unlike switching regulators, the MAX845's supply current is fairly constant, and is therefore less dependent on the input bypass capacitor. A low-cost 0.33 $\mu$ F chip or ceramic capacitor is normally sufficient for input bypassing.

# Isolated Transformer Driver for PCMCIA Applications

MAX845

**Table 2. Rectifier Topology Trade-Offs**

TOPOLOGY	ADVANTAGE	DISADVANTAGE
2-Diode Push/Pull (Figure 11a)	<ul style="list-style-type: none"> <li>• Only 3 external components</li> <li>• Low output ripple</li> <li>• Single diode drop</li> </ul>	<ul style="list-style-type: none"> <li>• More turns on transformer</li> </ul>
4-Diode Bridge (Figure 11b)	<ul style="list-style-type: none"> <li>• Simpler transformer winding requirements</li> <li>• Low output ripple</li> </ul>	<ul style="list-style-type: none"> <li>• 5 external components</li> <li>• Higher cost</li> <li>• 2 diode drops</li> </ul>
Voltage Doubler (Figure 11c)	<ul style="list-style-type: none"> <li>• Fewest turns on transformer</li> </ul>	<ul style="list-style-type: none"> <li>• 4 external components</li> <li>• Higher output ripple</li> <li>• 2 diode drops</li> </ul>

**Table 3. Suggested Capacitor Suppliers**

CAPACITOR	SUPPLIER
Low-ESR 267 Series	Matsuo USA Phone: (714) 969-2491 FAX: (714) 960-6492
Ceramic	Murata Erie USA Phone: (800) 831-9172 FAX: (404) 436-3030
Very Low-ESR 595D/293D Series	Sprague Electric Co. USA Phone: (603) 224-1961 FAX: (603) 224-1430

## Chip Topography

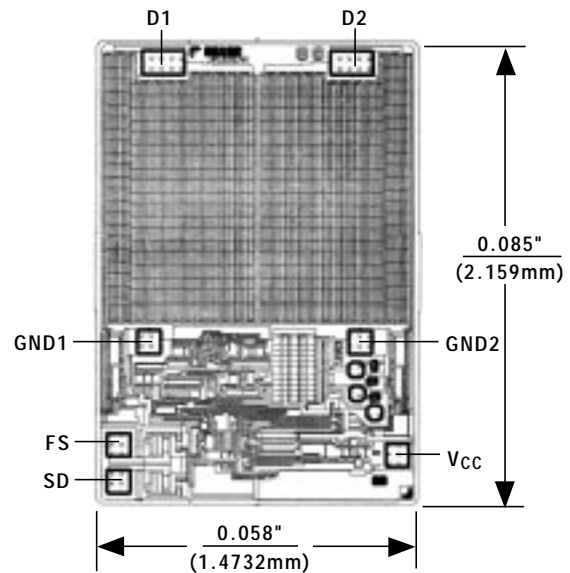

SUBSTRATE CONNECTED TO V<sub>CC</sub>  
TRANSISTOR COUNT: 31

# Isolated Transformer Driver for PCMCIA Applications

## Package Information

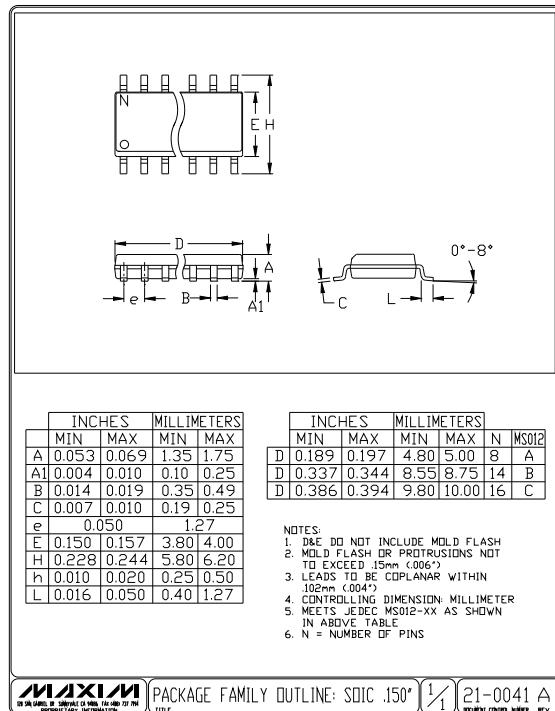
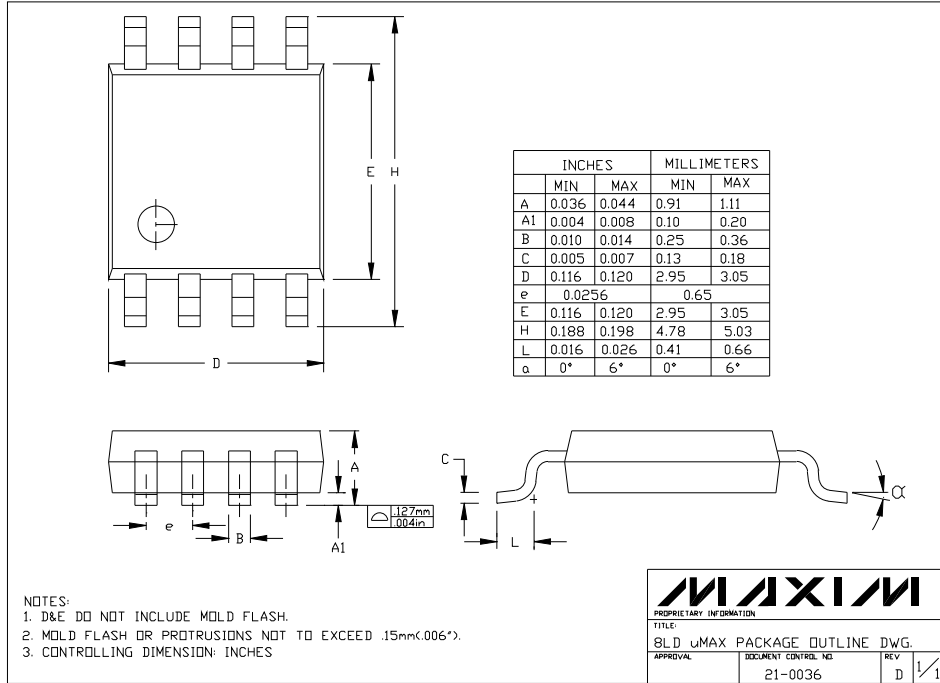

## Looking for pricing, stock, or lifecycle information?

Click below to explore more details on WIN SOURCE:

- ⊖ [View MAX845ESA+TG55 on WIN SOURCE](#)
- ⊖ [Maxim Integrated Information](#)

## Optimize Your Supply Chain with WIN SOURCE Solutions

- ✓ Global Sourcing Solution
- ✓ Obsolete Management
- ✓ Cost Control Management
- ✓ Shortage Management
- ✓ Alternative Solution
- ✓ Excess Inventory Management