



# THE DATASHEET OF MAX921CPA



## ISO732x Robust EMC, Low Power, Dual-Channel Digital Isolators

### 1 Features

- Signaling Rate: 25 Mbps
- Integrated Noise Filter on the Inputs
- Default Output 'High' and 'Low' Options
- Low Power Consumption: Typical  $I_{CC}$  per Channel at 1 Mbps:
  - ISO7320: 1.2 mA (5 V Supplies), 0.9 mA (3.3 V Supplies)
  - ISO7321: 1.7 mA (5 V Supplies), 1.2 mA (3.3 V Supplies)
- Low Propagation Delay: 33 ns Typical (5V Supplies)
- 3.3 V and 5 V Level Translation
- Wide Temperature Range:  $-40^{\circ}\text{C}$  to  $125^{\circ}\text{C}$
- 65 KV/ $\mu\text{s}$  Transient Immunity, Typical (5V Supplies)
- Robust Electromagnetic Compatibility (EMC)
  - System-level ESD, EFT, and Surge Immunity
  - Low Emissions
- Isolation Barrier Life: > 25 Years
- Operates from 3.3 V and 5 V Supplies
- Narrow Body SOIC-8 Package
- Safety and Regulatory Approvals:
  - 4242  $V_{PK}$  Isolation per DIN V VDE V 0884-10 and DIN EN 61010-1
  - 3000  $V_{RMS}$  Isolation for 1 minute per UL 1577
  - CSA Component Acceptance Notice 5A, IEC 60950-1 and IEC 61010-1 Standards
  - CQC Certification per GB4943.1-2011

### 2 Applications

- Opto-Coupler Replacement in:
  - Industrial FieldBus
    - ProfiBus
    - ModBus
    - DeviceNet™ Data Buses
  - Servo Control Interface
  - Motor Control
  - Power Supplies
  - Battery Packs

### 3 Description

ISO732x provide galvanic isolation up to 3000  $V_{RMS}$  for 1 minute per UL and 4242  $V_{PK}$  per VDE. These devices have two isolated channels comprised of logic input and output buffers separated by silicon dioxide ( $\text{SiO}_2$ ) insulation barriers. ISO7320 has both channels in the same direction while ISO7321 has the two channels in opposite direction. In case of input power or signal loss, default output is 'low' for devices with suffix 'F' and 'high' for devices without suffix 'F'. See [Device Functional Modes](#) for further details. Used in conjunction with isolated power supplies, these devices prevent noise currents on a data bus or other circuits from entering the local ground and interfering with or damaging sensitive circuitry. ISO732x have integrated noise filters for harsh industrial environment where short noise pulses may be present at the device input pins. ISO732x have TTL input thresholds and operate from 3 V to 5.5 V supply levels. Through innovative chip design and layout techniques, electromagnetic compatibility of ISO732x have been significantly enhanced to enable system-level ESD, EFT, Surge and Emissions compliance.

#### Device Information<sup>(1)</sup>

PART NUMBER	PACKAGE	BODY SIZE (NOM)
ISO7320C	SOIC (8)	4,90mm x 3,91mm
ISO7320FC		
ISO7321C		
ISO7321FC		

(1) For all available packages, see the orderable addendum at the end of the datasheet.

#### Simplified Schematic

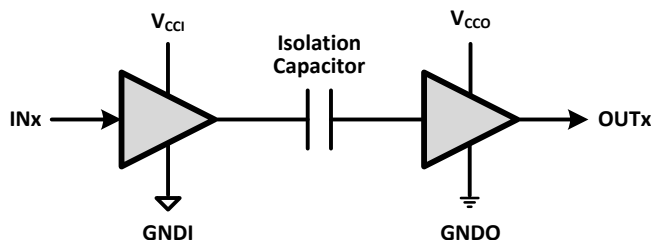

- (1)  $V_{CCI}$  and  $GNDI$  are supply and ground connections respectively for the input channels.
- (2)  $V_{CCO}$  and  $GNDO$  are supply and ground connections respectively for the output channels.



## Table of Contents

<b>1 Features</b> .....	1	8.2 Functional Block Diagram .....	10
<b>2 Applications</b> .....	1	8.3 Feature Description .....	11
<b>3 Description</b> .....	1	8.4 Device Functional Modes .....	14
<b>4 Revision History</b> .....	2	<b>9 Applications and Implementation</b> .....	15
<b>5 Pin Configuration and Functions</b> .....	3	9.1 Application Information .....	15
<b>6 Specifications</b> .....	4	9.2 Typical Application .....	15
6.1 Absolute Maximum Ratings .....	4	<b>10 Power Supply Recommendations</b> .....	17
6.2 ESD Ratings .....	4	<b>11 Layout</b> .....	17
6.3 Recommended Operating Conditions .....	4	11.1 PCB Material .....	17
6.4 Thermal Information .....	4	11.2 Layout Guidelines .....	17
6.5 Electrical Characteristics, 5 V .....	5	11.3 Layout Example .....	17
6.6 Electrical Characteristics, 3.3 V .....	5	<b>12 Device and Documentation Support</b> .....	18
6.7 Switching Characteristics, 5 V .....	6	12.1 Related Links .....	18
6.8 Switching Characteristics, 3.3 V .....	6	12.2 Trademarks .....	18
6.9 Typical Characteristics .....	7	12.3 Electrostatic Discharge Caution .....	18
<b>7 Parameter Measurement Information</b> .....	9	12.4 Glossary .....	18
<b>8 Detailed Description</b> .....	10	<b>13 Mechanical, Packaging, and Orderable Information</b> .....	18
8.1 Overview .....	10		

## 4 Revision History

Changes from Revision B (April 2015) to Revision C	Page
• Added "and DINEN 61010-1" to the 4242 VPK in the <i>Features</i> .....	1
• Deleted "(Approval Pending)" from the the CSA Component Acceptance list item in <i>Features</i> .....	1
• Changed From: $V_{CC1}$ To: $V_{CC1}$ in <i>Figure 11</i> .....	9
• Changed From: $V_{CC1}$ To: $V_{CC1}$ and From: $V_{CC2}$ To: $V_{CC0}$ in <i>Figure 13</i> .....	9
• Deleted IEC from the section title: <i>Insulation and Safety-Related Specifications for D-8 Package</i> .....	11
• Changed the CTI Test Conditions in <i>Insulation and Safety-Related Specifications for D-8 Package</i> .....	11
• Changed $V_{ISO}$ Test Condition in the <i>Insulation Characteristics</i> table .....	12

Changes from Revision A (March 2015) to Revision B	Page
• Changed from device status From: Product Preview To: Production .....	1

Changes from Original (January 2015) to Revision A	Page
• Changed from First page only to the full datasheet. ....	1
• Changed $V_{CC1}$ to $V_{CC1}$ , $V_{CC2}$ to $V_{CC0}$ , GND1 to GND1, GND2 to GND0 and added foot notes to the <i>Simplified Schematic</i> ..	1

## 5 Pin Configuration and Functions

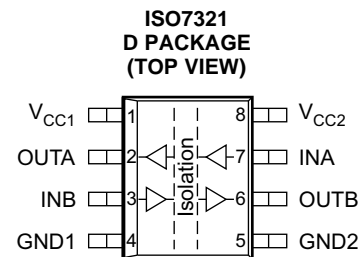
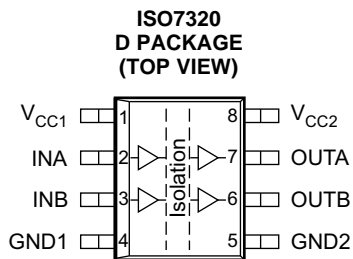

### Pin Functions

NAME	PIN		I/O	DESCRIPTION
	ISO7320	ISO7321		
INA	2	7	I	Input, channel A
INB	3	3	I	Input, channel B
GND1	4	4	–	Ground connection for $V_{CC1}$
GND2	5	5	–	Ground connection for $V_{CC2}$
OUTA	7	2	O	Output, channel A
OUTB	6	6	O	Output, channel B
$V_{CC1}$	1	1	–	Power supply, $V_{CC1}$
$V_{CC2}$	8	8	–	Power supply, $V_{CC2}$

## 6 Specifications

### 6.1 Absolute Maximum Ratings<sup>(1)</sup>

	MIN	MAX	UNIT
Supply voltage, $V_{CC1}$ , $V_{CC2}$ <sup>(2)</sup>	-0.5	6	V
Voltage <sup>(2)</sup>   INx, OUTx	-0.5	$V_{CC} + 0.5$ <sup>(3)</sup>	V
Output current, $I_O$		±15	mA
Junction temperature, $T_J$		150	°C
Storage temperature, $T_{stg}$	-65	150	°C

- (1) Stresses beyond those listed under *absolute maximum ratings* may cause permanent damage to the device. These are stress ratings only and functional operation of the device at these or any other conditions beyond those indicated under *recommended operating conditions* is not implied. Exposure to absolute-maximum-rated conditions for extended periods may affect device reliability.
- (2) All voltage values are with respect to network ground terminal and are peak voltage values.
- (3) Maximum voltage must not exceed 6 V.

### 6.2 ESD Ratings

	VALUE	UNIT
$V_{ESD}$	Human body model (HBM), per ANSI/ESDA/JEDEC JS-001 <sup>(1)</sup>	±4000
	Charged device model (CDM), per JEDEC specification JESD22-C101 <sup>(2)</sup>	±1500

- (1) JEDEC document JEP155 states that 500-V HBM allows safe manufacturing with a standard ESD control process.
- (2) JEDEC document JEP157 states that 250-V CDM allows safe manufacturing with a standard ESD control process.

### 6.3 Recommended Operating Conditions

	MIN	TYP	MAX	UNIT
$V_{CC1}$ , $V_{CC2}$   Supply voltage	3		5.5	V
$I_{OH}$   High-level output current	-4			mA
$I_{OL}$   Low-level output current			4	mA
$V_{IH}$   High-level input voltage	2		5.5	V
$V_{IL}$   Low-level input voltage	0		0.8	V
$t_{ui}$   Input pulse duration	40			ns
$1 / t_{ui}$   Signaling rate	0		25	Mbps
$T_J$ <sup>(1)</sup>   Junction temperature			136	°C
$T_A$   Ambient temperature	-40	25	125	°C

- (1) To maintain the recommended operating conditions for  $T_J$ , see the [Thermal Information](#) table.

### 6.4 Thermal Information

THERMAL METRIC <sup>(1)</sup>		D PACKAGE	UNIT
		(8) PINS	
$R_{\theta JA}$	Junction-to-ambient thermal resistance	121	°C/W
$R_{\theta Jtop}$	Junction-to-case (top) thermal resistance	67.9	
$R_{\theta JB}$	Junction-to-board thermal resistance	61.6	
$\Psi_{JT}$	Junction-to-top characterization parameter	21.5	
$\Psi_{JB}$	Junction-to-board characterization parameter	61.1	
$R_{\theta Jcbot}$	Junction-to-case (bottom) thermal resistance	N/A	
$P_D$ (ISO7320)	Maximum power dissipation by ISO7320	56	mW
$P_{D1}$ (ISO7320)	Maximum power dissipation by side-1 of ISO7320	15	
$P_{D2}$ (ISO7320)	Maximum power dissipation by side-2 of ISO7320	41	
$P_D$ (ISO7321)	Maximum power dissipation by ISO7321	67	mW
$P_{D1}$ (ISO7321)	Maximum power dissipation by side-1 of ISO7321	33.5	
$P_{D2}$ (ISO7321)	Maximum power dissipation by side-2 of ISO7321	33.5	

- (1) For more information about traditional and new thermal metrics, see the IC Package Thermal Metrics application report, [SPRA953](#).

## 6.5 Electrical Characteristics, 5 V

 $V_{CC1}$  and  $V_{CC2}$  at 5 V  $\pm$  10% (over recommended operating conditions unless otherwise noted)

PARAMETER		TEST CONDITIONS		MIN	TYP	MAX	UNIT
$V_{OH}$	High-level output voltage	$I_{OH} = -4$ mA; see <a href="#">Figure 11</a>		$V_{CCO}^{(1)} - 0.5$	4.7		V
		$I_{OH} = -20$ $\mu$ A; see <a href="#">Figure 11</a>		$V_{CCO}^{(1)} - 0.1$	5		
$V_{OL}$	Low-level output voltage	$I_{OL} = 4$ mA; see <a href="#">Figure 11</a>			0.2	0.4	V
		$I_{OL} = 20$ $\mu$ A; see <a href="#">Figure 11</a>			0	0.1	
$V_{I(HYS)}$	Input threshold voltage hysteresis				460		mV
$I_{IH}$	High-level input current	$I_N = V_{CC}$				10	$\mu$ A
$I_{IL}$	Low-level input current	$I_N = 0$ V		-10			$\mu$ A
CMTI	Common-mode transient immunity	$V_I = V_{CC}$ or 0 V; see <a href="#">Figure 13</a> .		25	65		kV/ $\mu$ s
<b>SUPPLY CURRENT (All inputs switching with square wave clock signal for dynamic <math>I_{CC}</math> measurement)</b>							
<b>ISO7320</b>							
$I_{CC1}$	Supply current for $V_{CC1}$ and $V_{CC2}$	DC to 1 Mbps	DC Input: $V_I = V_{CC}$ or 0 V, AC Input: $C_L = 15$ pF		0.4	0.9	mA
$I_{CC2}$					2	3.2	
$I_{CC1}$		10 Mbps	$C_L = 15$ pF		0.8	1.4	
$I_{CC2}$					3.2	4.4	
$I_{CC1}$		25 Mbps	$C_L = 15$ pF		1.4	2.3	
$I_{CC2}$					4.9	6.8	
<b>ISO7321</b>							
$I_{CC1}, I_{CC2}$	Supply current for $V_{CC1}$ and $V_{CC2}$	DC to 1 Mbps	DC Input: $V_I = V_{CC}$ or 0 V, AC Input: $C_L = 15$ pF		1.7	2.8	mA
$I_{CC1}, I_{CC2}$		10 Mbps	$C_L = 15$ pF		2.5	3.7	
$I_{CC1}, I_{CC2}$		25 Mbps	$C_L = 15$ pF		3.7	5.4	

(1)  $V_{CCO}$  is supply voltage,  $V_{CC1}$  or  $V_{CC2}$ , for the output channel being measured.

## 6.6 Electrical Characteristics, 3.3 V

 $V_{CC1}$  and  $V_{CC2}$  at 3.3 V  $\pm$  10% (over recommended operating conditions unless otherwise noted)

PARAMETER		TEST CONDITIONS		MIN	TYP	MAX	UNIT
$V_{OH}$	High-level output voltage	$I_{OH} = -4$ mA; see <a href="#">Figure 11</a>		$V_{CCO}^{(1)} - 0.5$	3		V
		$I_{OH} = -20$ $\mu$ A; see <a href="#">Figure 11</a>		$V_{CCO}^{(1)} - 0.1$	3.3		
$V_{OL}$	Low-level output voltage	$I_{OL} = 4$ mA; see <a href="#">Figure 11</a>			0.2	0.4	V
		$I_{OL} = 20$ $\mu$ A; see <a href="#">Figure 11</a>			0	0.1	
$V_{I(HYS)}$	Input threshold voltage hysteresis				450		mV
$I_{IH}$	High-level input current	$I_N = V_{CC}$				10	$\mu$ A
$I_{IL}$	Low-level input current	$I_N = 0$ V		-10			$\mu$ A
CMTI	Common-mode transient immunity	$V_I = V_{CC}$ or 0 V; see <a href="#">Figure 13</a>		25	50		kV/ $\mu$ s
<b>SUPPLY CURRENT (All inputs switching with square wave clock signal for dynamic <math>I_{CC}</math> measurement)</b>							
<b>ISO7320</b>							
$I_{CC1}$	Supply current for $V_{CC1}$ and $V_{CC2}$	DC to 1 Mbps	DC Input: $V_I = V_{CC}$ or 0 V, AC Input: $C_L = 15$ pF		0.2	0.5	mA
$I_{CC2}$					1.5	2.5	
$I_{CC1}$		10 Mbps	$C_L = 15$ pF		0.5	0.8	
$I_{CC2}$					2.2	3.2	
$I_{CC1}$		25 Mbps	$C_L = 15$ pF		0.9	1.4	
$I_{CC2}$					3.3	4.7	
<b>ISO7321</b>							
$I_{CC1}, I_{CC2}$	Supply current for $V_{CC1}$ and $V_{CC2}$	DC to 1 Mbps	DC Input: $V_I = V_{CC}$ or 0 V, AC Input: $C_L = 15$ pF		1.2	2	mA
$I_{CC1}, I_{CC2}$		10 Mbps	$C_L = 15$ pF		1.7	2.5	
$I_{CC1}, I_{CC2}$		25 Mbps	$C_L = 15$ pF		2.5	3.6	

(1)  $V_{CCO}$  is supply voltage,  $V_{CC1}$  or  $V_{CC2}$ , for the output channel being measured.

## 6.7 Switching Characteristics, 5 V

 $V_{CC1}$  and  $V_{CC2}$  at 5 V  $\pm$  10% (over recommended operating conditions unless otherwise noted)

PARAMETER		TEST CONDITIONS	MIN	TYP	MAX	UNIT
$t_{PLH}$ , $t_{PHL}$	Propagation delay time	See Figure 11	20	33	57	ns
PWD <sup>(1)</sup>	Pulse width distortion $ t_{PHL} - t_{PLH} $				4	ns
$t_{sk(o)}$ <sup>(2)</sup>	Channel-to-channel output skew time	ISO7320			2	ns
		ISO7321			17	
$t_{sk(pp)}$ <sup>(3)</sup>	Part-to-part skew time				23	ns
$t_r$	Output signal rise time	See Figure 11		2.4		ns
$t_f$	Output signal fall time			2.1		ns
$t_{fs}$	Fail-safe output delay time from input power loss	See Figure 12		7.5		$\mu$ s

- (1) Also known as pulse skew.
- (2)  $t_{sk(o)}$  is the skew between outputs of a single device with all driving inputs connected together and the outputs switching in the same direction while driving identical loads.
- (3)  $t_{sk(pp)}$  is the magnitude of the difference in propagation delay times between any terminals of different devices switching in the same direction while operating at identical supply voltages, temperature, input signals and loads.

## 6.8 Switching Characteristics, 3.3 V

 $V_{CC1}$  and  $V_{CC2}$  at 3.3 V  $\pm$  10% (over recommended operating conditions unless otherwise noted)

PARAMETER		TEST CONDITIONS	MIN	TYP	MAX	UNIT3
$t_{PLH}$ , $t_{PHL}$	Propagation delay time	See Figure 11	22	37	66	ns
PWD <sup>(1)</sup>	Pulse width distortion $ t_{PHL} - t_{PLH} $				3	ns
$t_{sk(o)}$ <sup>(2)</sup>	Channel-to-channel output skew time	ISO7320			3	ns
		ISO7321			16	
$t_{sk(pp)}$ <sup>(3)</sup>	Part-to-part skew time				28	ns
$t_r$	Output signal rise time	See Figure 11		3.1		ns
$t_f$	Output signal fall time			2.6		ns
$t_{fs}$	Fail-safe output delay time from input power loss	See Figure 12		7.4		$\mu$ s

- (1) Also known as pulse skew.
- (2)  $t_{sk(o)}$  is the skew between outputs of a single device with all driving inputs connected together and the outputs switching in the same direction while driving identical loads.
- (3)  $t_{sk(pp)}$  is the magnitude of the difference in propagation delay times between any terminals of different devices switching in the same direction while operating at identical supply voltages, temperature, input signals and loads.

## 6.9 Typical Characteristics

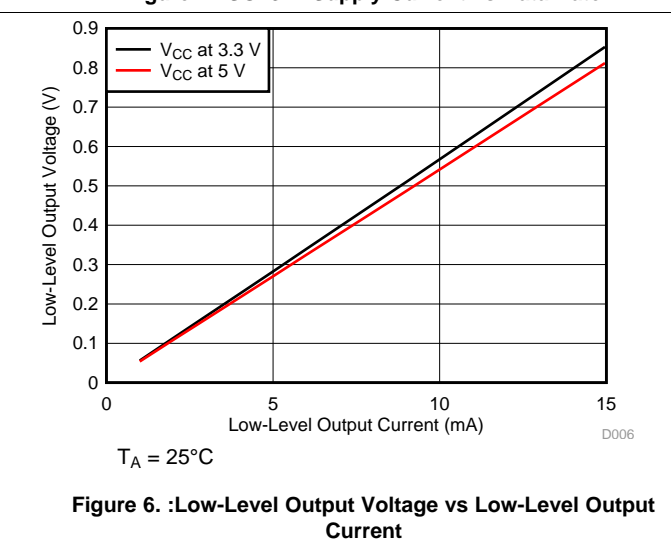
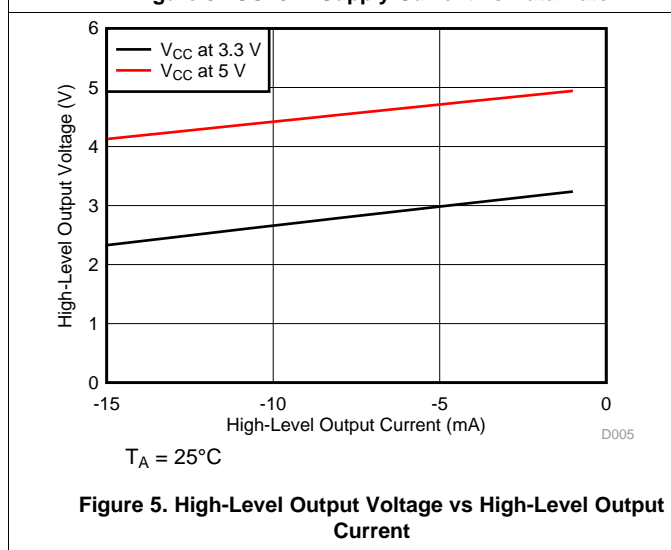
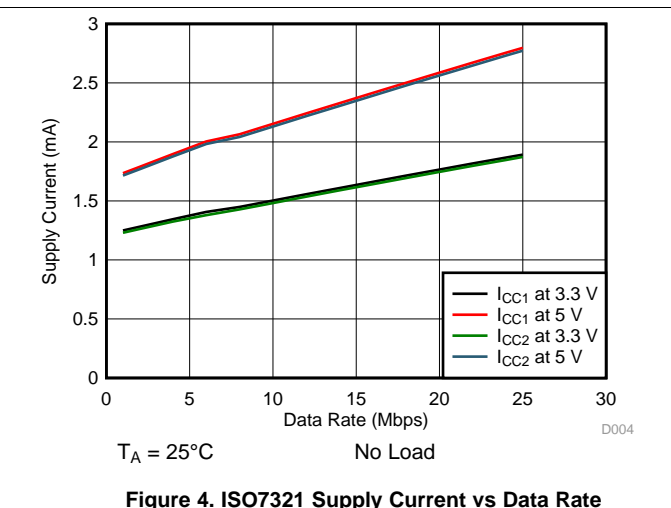
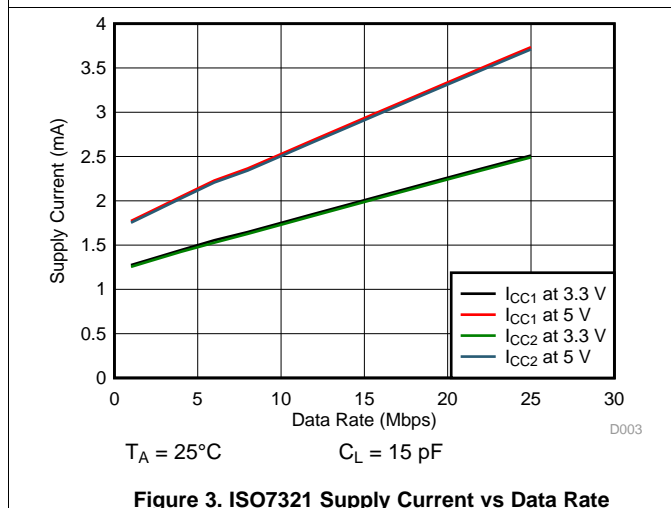
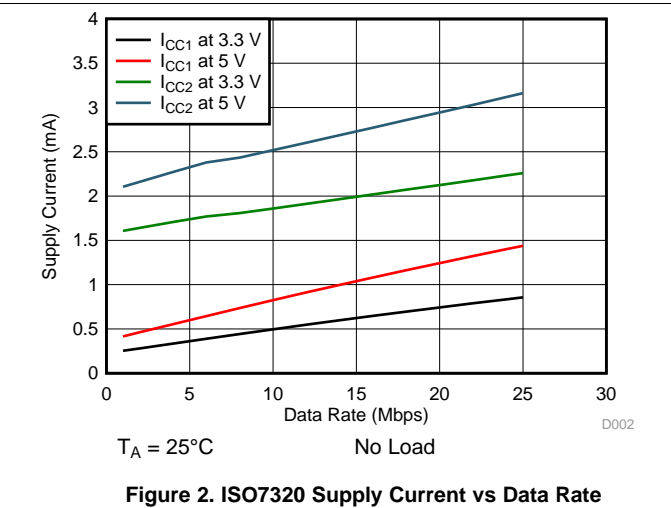
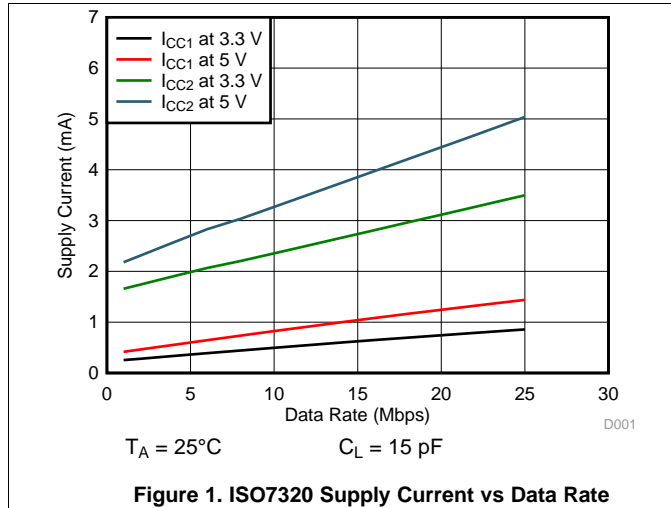

Typical Characteristics (continued)

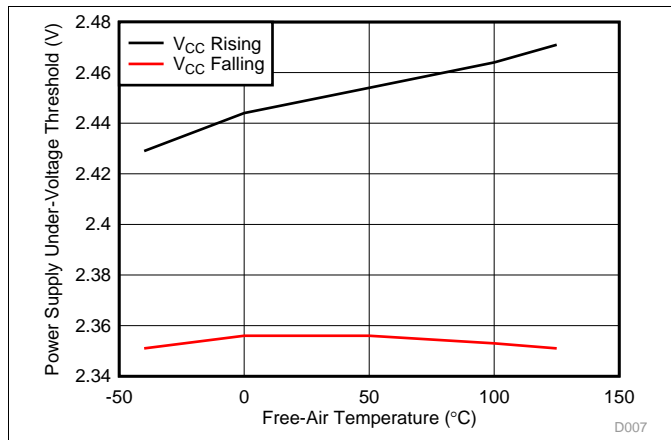

Figure 7. Power Supply Under Voltage Threshold vs Free-Air Temperature

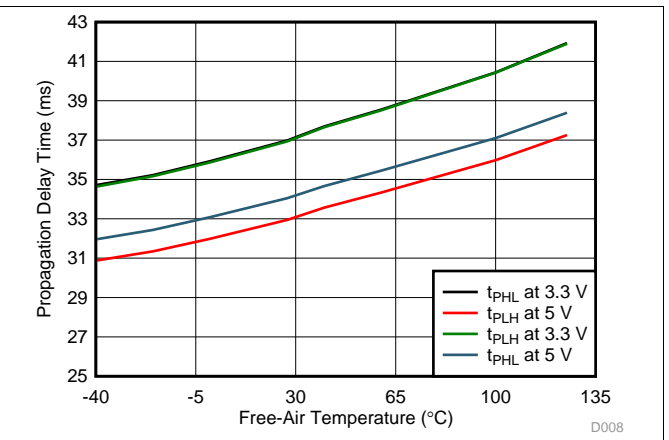

Figure 8. Propagation Delay Time vs Free-Air Temperature

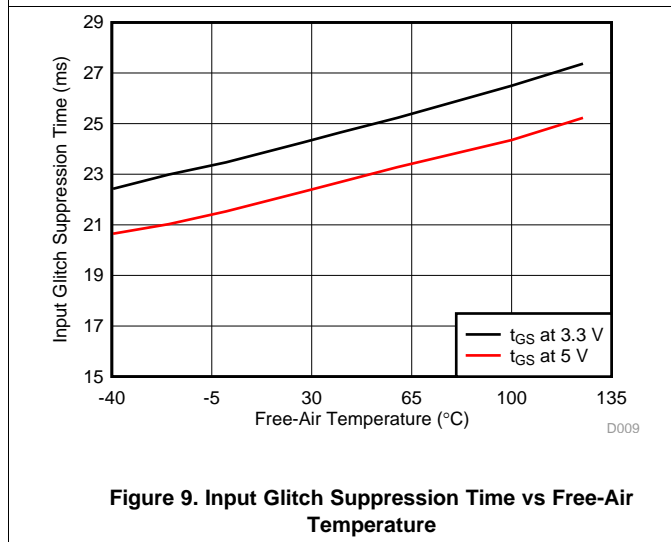

Figure 9. Input Glitch Suppression Time vs Free-Air Temperature

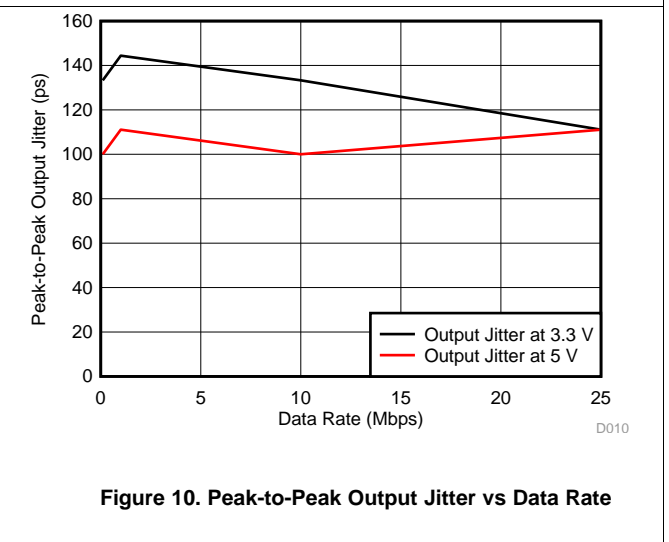
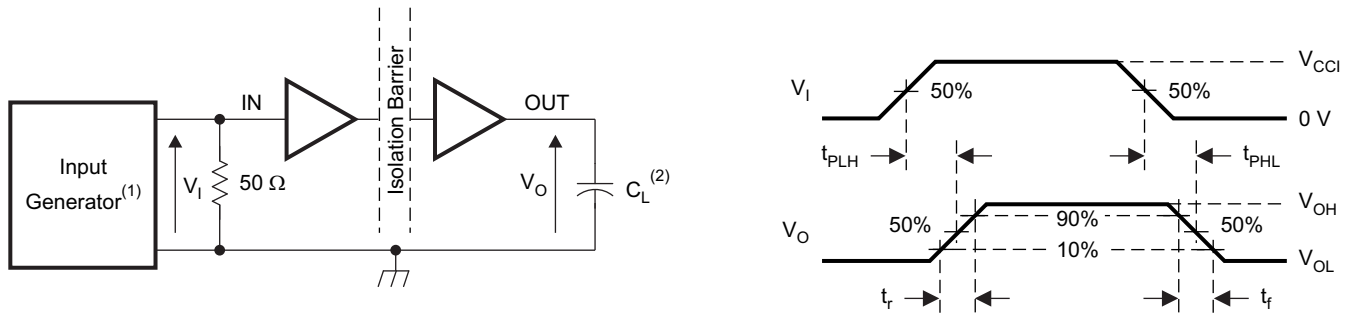

Figure 10. Peak-to-Peak Output Jitter vs Data Rate

## 7 Parameter Measurement Information



- (1) The input pulse is supplied by a generator having the following characteristics: PRR  $\leq$  50 kHz, 50% duty cycle,  $t_r \leq$  3 ns,  $t_f \leq$  3 ns,  $Z_O = 50 \Omega$ . At the input, a 50- $\Omega$  resistor is required to terminate the Input Generator signal. It is not needed in actual application.
- (2)  $C_L = 15$  pF and includes instrumentation and fixture capacitance within  $\pm 20\%$ .

**Figure 11. Switching Characteristic Test Circuit and Voltage Waveforms**

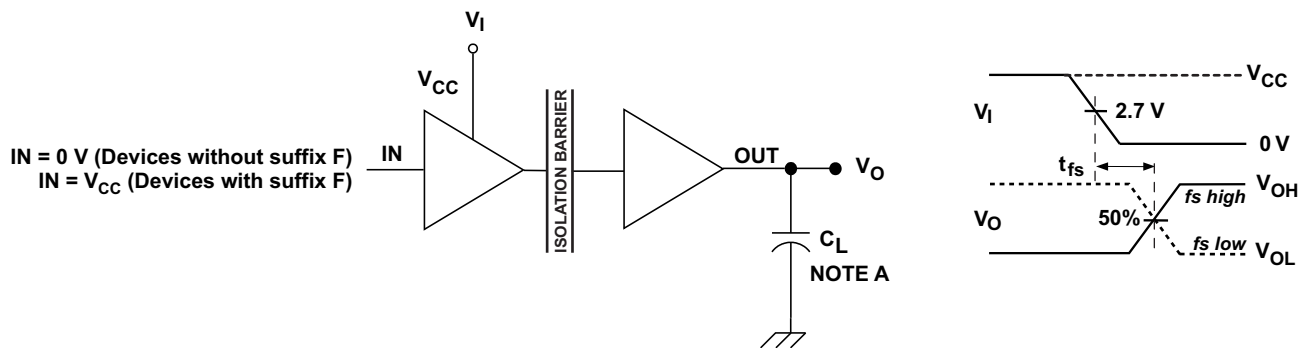

- A.  $C_L = 15$  pF and includes instrumentation and fixture capacitance within  $\pm 20\%$ .

**Figure 12. Fail-Safe Output Delay-Time Test Circuit and Voltage Waveforms**

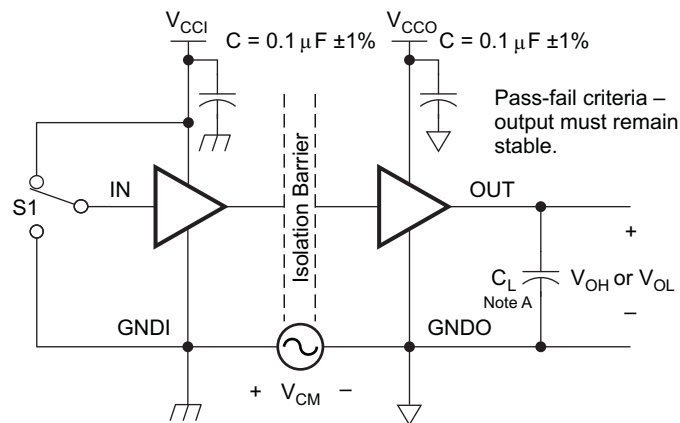

- (1)  $C_L = 15$  pF and includes instrumentation and fixture capacitance within  $\pm 20\%$ .

**Figure 13. Common-Mode Transient Immunity Test Circuit**

## 8 Detailed Description

### 8.1 Overview

The isolator in [Figure 14](#) is based on a capacitive isolation barrier technique. The I/O channel of the device consists of two internal data channels, a high-frequency (HF) channel with a bandwidth from 100 kbps up to 25 Mbps, and a low-frequency (LF) channel covering the range from 100 kbps down to DC.

In principle, a single-ended input signal entering the HF channel is split into a differential signal via the inverter gate at the input. The following capacitor-resistor networks differentiate the signal into transient pulses, which then are converted into CMOS levels by a comparator. The transient pulses at the input of the comparator can be either above or below the common mode voltage  $V_{REF}$  depending on whether the input bit transitioned from 0 to 1 or 1 to 0. The comparator threshold is adjusted based on the expected bit transition. A decision logic (DCL) at the output of the HF channel comparator measures the durations between signal transients. If the duration between two consecutive transients exceeds a certain time limit, (as in the case of a low-frequency signal), the DCL forces the output-multiplexer to switch from the high-frequency to the low-frequency channel.

### 8.2 Functional Block Diagram

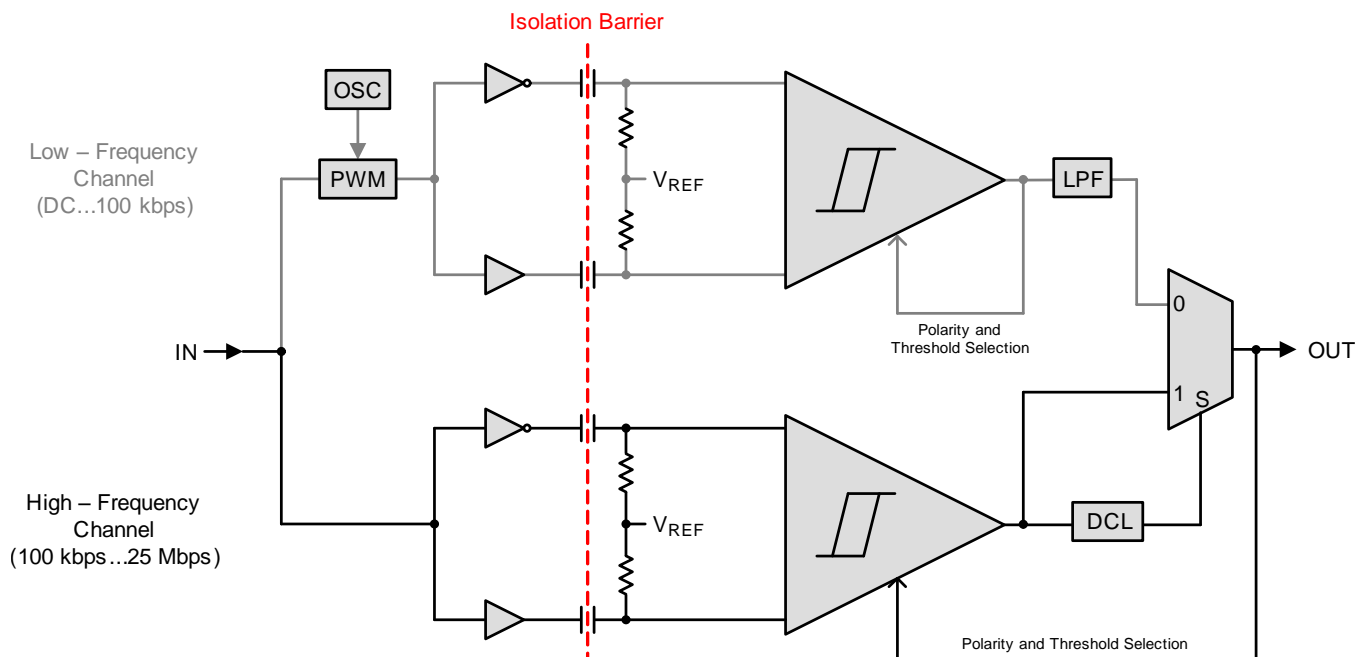

Figure 14. Conceptual Block Diagram of a Digital Capacitive Isolator

Because low-frequency input signals require the internal capacitors to assume prohibitively large values, these signals are pulse-width modulated (PWM) with the carrier frequency of an internal oscillator, thus creating a sufficiently high frequency, capable of passing the capacitive barrier. As the input is modulated, a low-pass filter (LPF) is needed to remove the high-frequency carrier from the actual data before passing it on to the output multiplexer.

### 8.3 Feature Description

PRODUCT	CHANNEL DIRECTION	RATED ISOLATION	MAX DATA RATE	DEFAULT OUTPUT
ISO7320C	Same	3000 V <sub>RMS</sub> / 4242 V <sub>PK</sub> <sup>(1)</sup>	25 Mbps	High
ISO7320FC				Low
ISO7321C	Opposite			High
ISO7321FC				Low

(1) See the [Regulatory Information](#) section for detailed Isolation Ratings

#### 8.3.1 High Voltage Feature Description

##### 8.3.1.1 Insulation and Safety-Related Specifications for D-8 Package

over recommended operating conditions (unless otherwise noted)

PARAMETER		TEST CONDITIONS	MIN	TYP	MAX	UNIT
L(I01)	Minimum air gap (clearance)	Shortest terminal-to-terminal distance through air	4			mm
L(I02)	Minimum external tracking (creepage)	Shortest terminal-to-terminal distance across the package surface	4			mm
CTI	Tracking resistance (comparative tracking index)	DIN EN 60112 (VDE 0303-11); IEC 60112	400			V
DTI	Minimum internal gap (internal clearance)	Distance through insulation	13			μm
R <sub>IO</sub>	Isolation resistance, input to output <sup>(1)</sup>	V <sub>IO</sub> = 500 V, T <sub>A</sub> = 25°C	10 <sup>12</sup>			Ω
		V <sub>IO</sub> = 500 V, 100°C ≤ T <sub>A</sub> ≤ 125°C	10 <sup>11</sup>			Ω
C <sub>IO</sub>	Isolation capacitance, input to output <sup>(1)</sup>	V <sub>IO</sub> = 0.4 sin (2πft), f = 1 MHz		1.5		pF
C <sub>I</sub>	Input capacitance <sup>(2)</sup>	V <sub>I</sub> = V <sub>CC</sub> /2 + 0.4 sin (2πft), f = 1 MHz, V <sub>CC</sub> = 5 V		1.8		pF

(1) All pins on each side of the barrier tied together creating a two-terminal device.

(2) Measured from input pin to ground.

#### NOTE

Creepage and clearance requirements should be applied according to the specific equipment isolation standards of an application. Care should be taken to maintain the creepage and clearance distance of a board design to ensure that the mounting pads of the isolator on the printed-circuit board do not reduce this distance.

Creepage and clearance on a printed-circuit board become equal in certain cases. Techniques such as inserting grooves and/or ribs on a printed circuit board are used to help increase these specifications.

### 8.3.1.2 Insulation Characteristics

over recommended operating conditions (unless otherwise noted)

PARAMETER <sup>(1)</sup>		TEST CONDITIONS	SPECIFICATION	UNIT
V <sub>IOWM</sub>	Maximum isolation working voltage		400	V <sub>RMS</sub>
V <sub>IORM</sub>	Maximum repetitive peak voltage per DIN V VDE V 0884-10		566	V <sub>PK</sub>
V <sub>PR</sub>	Input-to-output test voltage per DIN V VDE V 0884-10	After Input/Output safety test subgroup 2/3, V <sub>PR</sub> = V <sub>IORM</sub> × 1.2, t = 10 s, Partial discharge < 5 pC	680	V <sub>PK</sub>
		Method a, After environmental tests subgroup 1, V <sub>PR</sub> = V <sub>IORM</sub> × 1.6, t = 10 s, Partial Discharge < 5 pC	906	
		Method b1, V <sub>PR</sub> = V <sub>IORM</sub> × 1.875, t = 1 s (100% Production test) Partial discharge < 5 pC	1062	
V <sub>IOTM</sub>	Maximum transient overvoltage per DIN V VDE V 0884-10	V <sub>TEST</sub> = V <sub>IOTM</sub> t = 60 sec (qualification) t = 1 sec (100% production)	4242	V <sub>PK</sub>
V <sub>IOSM</sub>	Maximum surge isolation voltage per DIN V VDE V 0884-10	Test method per IEC 60065, 1.2/50 μs waveform, V <sub>TEST</sub> = 1.3 × V <sub>IOSM</sub> = 7800 V <sub>PK</sub> (qualification)	6000	V <sub>PK</sub>
V <sub>ISO</sub>	Withstand isolation voltage per UL 1577	V <sub>TEST</sub> = V <sub>ISO</sub> = 3000 V <sub>RMS</sub> , t = 60 sec (qualification); V <sub>TEST</sub> = 1.2 × V <sub>ISO</sub> = 3600 V <sub>RMS</sub> , t = 1 sec (100% production)	3000	V <sub>RMS</sub>
R <sub>S</sub>	Insulation resistance	V <sub>IO</sub> = 500 V at T <sub>S</sub>	>10 <sup>9</sup>	Ω
	Pollution degree		2	

(1) Climatic Classification 40/125/21

**Table 1. IEC 60664-1 Ratings Table**

PARAMETER	TEST CONDITIONS	SPECIFICATION
Basic isolation group	Material group	II
Installation classification	Rated mains voltage ≤ 150 V <sub>RMS</sub>	I–IV
	Rated mains voltage ≤ 300 V <sub>RMS</sub>	I–III

### 8.3.1.3 Regulatory Information

VDE	CSA	UL	CQC
Certified according to DIN V VDE V 0884-10 (VDE V 0884-10):2006-12	Approved under CSA Component Acceptance Notice 5A, IEC 60950-1, and IEC 61010-1	Recognized under UL 1577 Component Recognition Program	Certified according to GB4943.1-2011
Basic Insulation Maximum Transient Overvoltage, 4242 V <sub>PK</sub> Maximum Surge Isolation Voltage, 6000 V <sub>PK</sub> Maximum Repetitive Peak Voltage, 566 V <sub>PK</sub>	400 V <sub>RMS</sub> Basic Insulation and 200 V <sub>RMS</sub> Reinforced Insulation working voltage per CSA 60950-1-07+A1+A2 and IEC 60950-1 2nd Ed.+A1+A2; 300 V <sub>RMS</sub> Basic Insulation working voltage per CSA 61010-1-12 and IEC 61010-1 3rd Ed.	Single protection, 3000 V <sub>RMS</sub> <sup>(1)</sup>	Basic Insulation, Altitude ≤ 5000 m, Tropical Climate, 250 V <sub>RMS</sub> maximum working voltage
Certificate number: 40016131	Master contract number: 220991	File number: E181974	Certificate number: CQC15001121656

 (1) Production tested ≥ 3600 V<sub>RMS</sub> for 1 second in accordance with UL 1577.

### 8.3.1.4 Safety Limiting Values

Safety limiting intends to prevent potential damage to the isolation barrier upon failure of input or output circuitry. A failure of the I/O can allow low resistance to ground or the supply and, without current limiting, dissipate sufficient power to overheat the die and damage the isolation barrier, potentially leading to secondary system failures.

PARAMETER	TEST CONDITIONS	MIN	TYP	MAX	UNIT
I <sub>S</sub>	R <sub>θJA</sub> = 121 °C/W, V <sub>I</sub> = 5.5 V, T <sub>J</sub> = 150°C, T <sub>A</sub> = 25°C			188	mA
	R <sub>θJA</sub> = 121 °C/W, V <sub>I</sub> = 3.6 V, T <sub>J</sub> = 150°C, T <sub>A</sub> = 25°C			287	
T <sub>S</sub>	Maximum case temperature			150	°C

The safety-limiting constraint is the absolute-maximum junction temperature specified in the [Absolut Maximun Ratings](#) table. The power dissipation and junction-to-air thermal impedance of the device installed in the application hardware determines the junction temperature. The assumed junction-to-air thermal resistance in the [Thermal Information](#) table is that of a device installed on a High-K Test Board for Leaded Surface-Mount Packages. The power is the recommended maximum input voltage times the current. The junction temperature is then the ambient temperature plus the power times the junction-to-air thermal resistance.

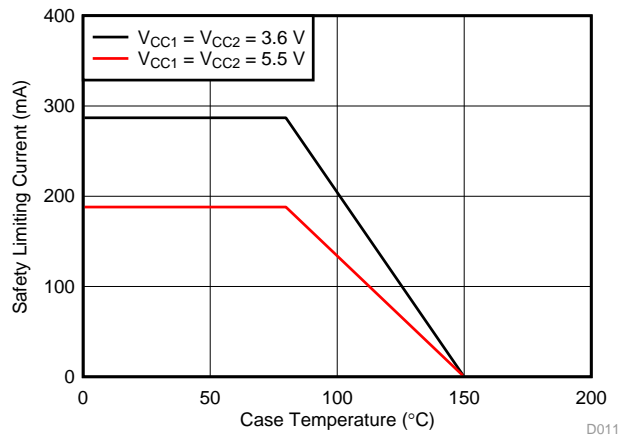

Figure 15.  $\theta_{JC}$  Thermal Derating Curve per DIN V VDE V 0884-10

### 8.4 Device Functional Modes

Table 2. Function Table<sup>(1)</sup>

V <sub>CCI</sub>	V <sub>CCO</sub>	INA, INB	OUTA, OUTB	
			ISO7320C, ISO7321C	ISO7320FC, ISO7321FC
PU	PU	H	H	H
		L	L	L
		Open	H <sup>(2)</sup>	L <sup>(3)</sup>
PD	PU	X	H <sup>(2)</sup>	L <sup>(3)</sup>
X	PD	X	Undetermined	Undetermined

- (1) V<sub>CCI</sub> = Input-side V<sub>CC</sub>; V<sub>CCO</sub> = Output-side V<sub>CC</sub>; PU = Powered up (V<sub>CC</sub> ≥ 3 V); PD = Powered down (V<sub>CC</sub> ≤ 2.1 V); X = Irrelevant; H = High level; L = Low level; Open = Not connected
- (2) In fail-safe condition, output defaults to high level
- (3) In fail-safe condition, output defaults to low level

#### 8.4.1 Device I/O Schematics

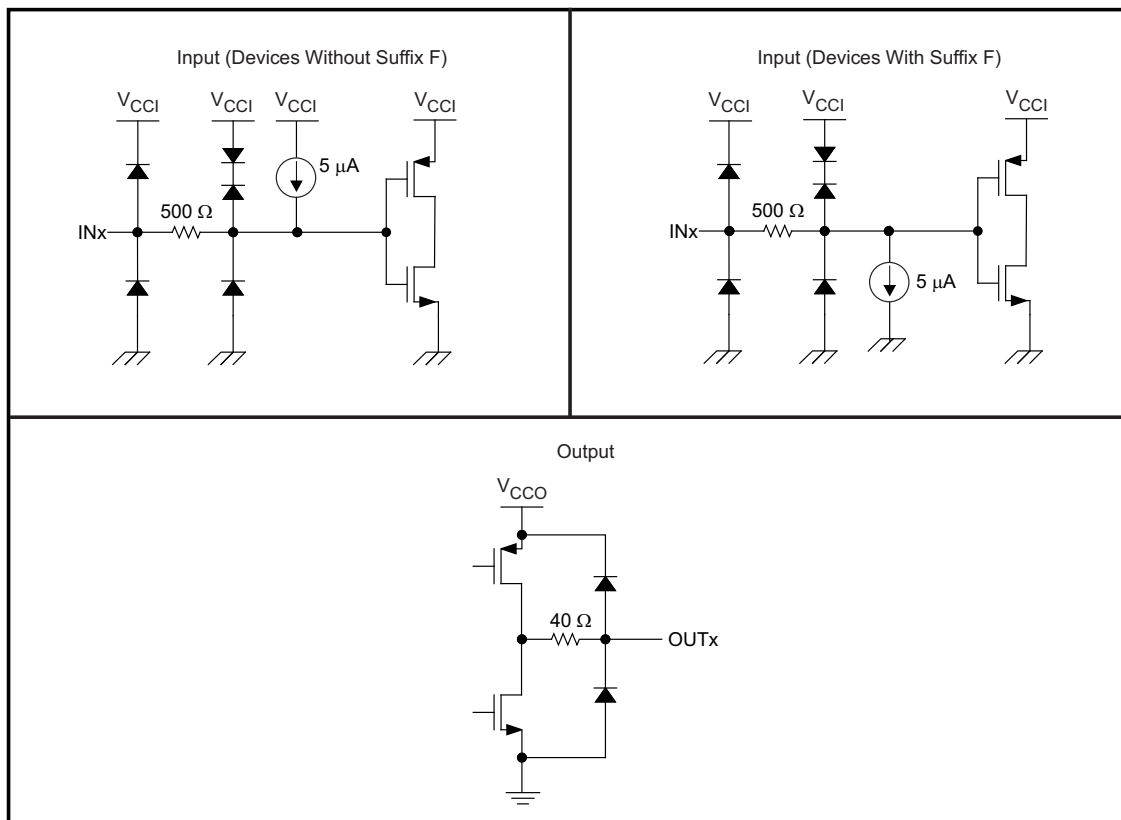

Figure 16. Device I/O Schematics

## 9 Applications and Implementation

### NOTE

Information in the following applications sections is not part of the TI component specification, and TI does not warrant its accuracy or completeness. TI's customers are responsible for determining suitability of components for their purposes. Customers should validate and test their design implementation to confirm system functionality.

### 9.1 Application Information

ISO732x utilize single-ended TTL-logic switching technology. Its supply voltage range is from 3 V to 5.5 V for both supplies,  $V_{CC1}$  and  $V_{CC2}$ . When designing with digital isolators, it is important to keep in mind that due to the single-ended design structure, digital isolators do not conform to any specific interface standard and are only intended for isolating single-ended CMOS or TTL digital signal lines. The isolator is typically placed between the data controller (i.e.  $\mu C$  or UART), and a data converter or a line transceiver, regardless of the interface type or standard.

### 9.2 Typical Application

ISO7321 can be used with Texas Instruments' mixed signal micro-controller, digital-to-analog converter, transformer driver, and voltage regulator to create an isolated 4-20 mA current loop.

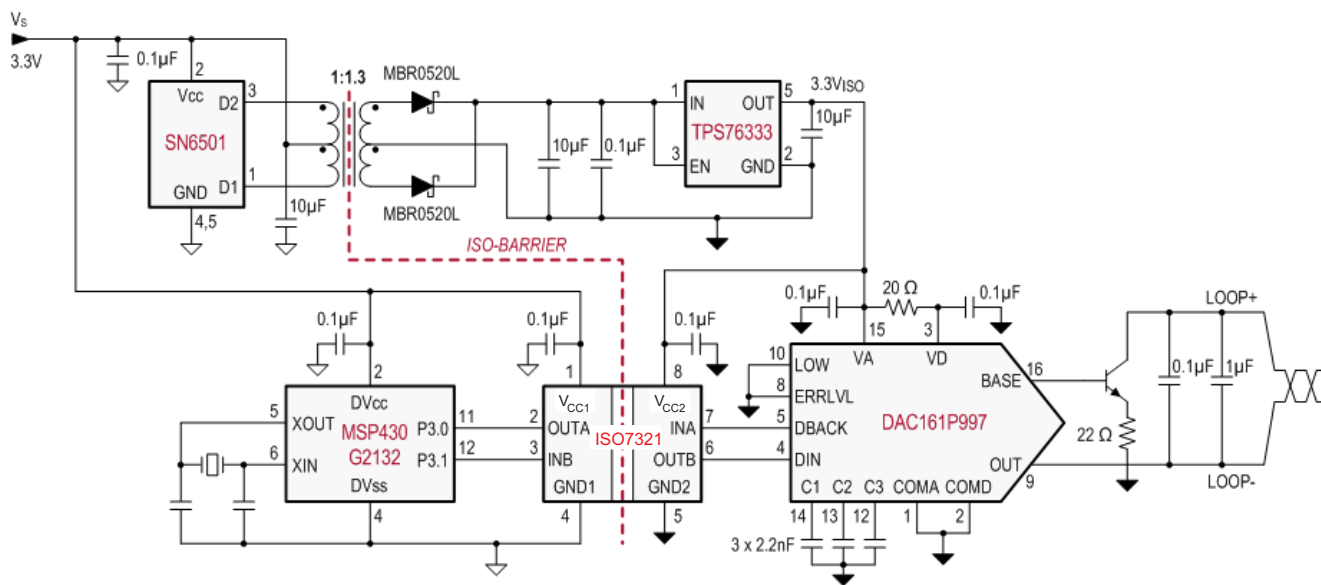

Figure 17. Typical ISO7321 Application Circuit

## Typical Application (continued)

### 9.2.1 Design Requirements

#### 9.2.1.1 Typical Supply Current Equations

##### ISO7320:

- At  $V_{CC1} = V_{CC2} = 5\text{ V}$
- $I_{CC1} = 0.3838 + (0.0431 \times f)$
  - $I_{CC2} = 2.74567 + (0.08433 \times f) + (0.01 \times f \times C_L)$
- At  $V_{CC1} = V_{CC2} = 3.3\text{ V}$
- $I_{CC1} = 0.2394 + (0.02355 \times f)$
  - $I_{CC2} = 2.10681 + (0.04374 \times f) + (0.007045 \times f \times C_L)$

##### ISO7321:

- At  $V_{CC1} = V_{CC2} = 5\text{ V}$
- $I_{CC1}$  and  $I_{CC2} = 1.5877 + (0.066 \times f) + (0.00123 \times f \times C_L)$
- At  $V_{CC1} = V_{CC2} = 3.3\text{ V}$
- $I_{CC1}$  and  $I_{CC2} = 1.187572 + (0.019399 \times f) + (0.0019029 \times f \times C_L)$

$I_{CC1}$  and  $I_{CC2}$  are typical supply currents measured in mA,  $f$  is data rate measured in Mbps,  $C_L$  is the capacitive load measured in pF.

### 9.2.2 Detailed Design Procedure

#### 9.2.2.1 Electromagnetic Compatibility (EMC) Considerations

Many applications in harsh industrial environment are sensitive to disturbances such as electrostatic discharge (ESD), electrical fast transient (EFT), surge and electromagnetic emissions. These electromagnetic disturbances are regulated by international standards such as IEC 61000-4-x and CISPR 22. Although system-level performance and reliability depends, to a large extent, on the application board design and layout, the ISO732x incorporate many chip-level design improvements for overall system robustness. Some of these improvements include:

- Robust ESD protection cells for input and output signal pins and inter-chip bond pads.
- Low-resistance connectivity of ESD cells to supply and ground pins.
- Enhanced performance of high voltage isolation capacitor for better tolerance of ESD, EFT and surge events.
- Bigger on-chip decoupling capacitors to bypass undesirable high energy signals through a low impedance path.
- PMOS and NMOS devices isolated from each other by using guard rings to avoid triggering of parasitic SCRs.
- Reduced common mode currents across the isolation barrier by ensuring purely differential internal operation.

### 9.2.3 Application Performance Curves

Typical eye diagrams of ISO732x below indicate low jitter and wide open eye at the maximum data rate of 25 Mbps.

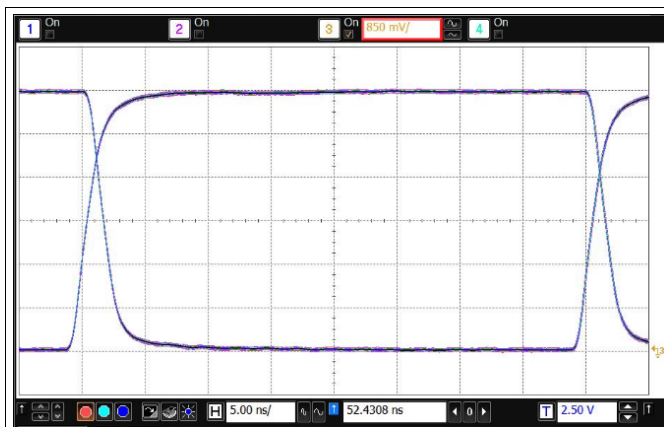

Figure 18. Eye Diagram at 25 Mbps, 5 V and 25°C

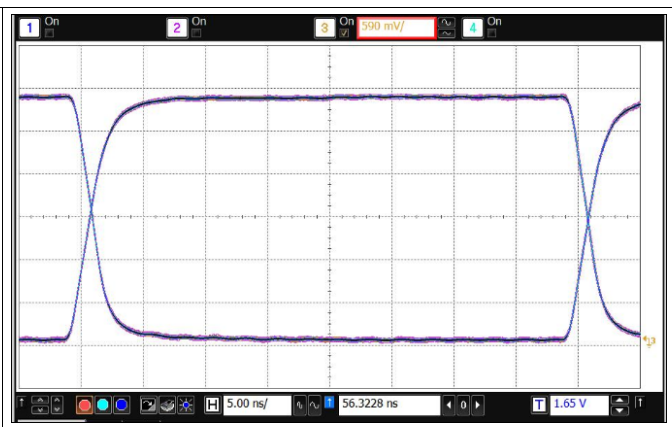

Figure 19. Eye Diagram at 25 Mbps, 3.3 V and 25°C

## 10 Power Supply Recommendations

To ensure reliable operation at all data rates and supply voltages, a 0.1  $\mu\text{F}$  bypass capacitor is recommended at input and output supply pins ( $V_{CC1}$  &  $V_{CC2}$ ). The capacitors should be placed as close to the supply pins as possible. If only a single primary-side power supply is available in an application, isolated power can be generated for the secondary-side with the help of a transformer driver such as Texas Instruments' [SN6501](#). For such applications, detailed power supply design and transformer selection recommendations are available in [SN6501](#) datasheet ([SLLSEA0](#)).

## 11 Layout

### 11.1 PCB Material

For digital circuit boards operating below 150 Mbps, (or rise and fall times higher than 1 ns), and trace lengths of up to 10 inches, use standard FR-4 epoxy-glass as PCB material. FR-4 (Flame Retardant 4) meets the requirements of Underwriters Laboratories UL94-V0, and is preferred over cheaper alternatives due to its lower dielectric losses at high frequencies, less moisture absorption, greater strength and stiffness, and its self-extinguishing flammability-characteristics.

### 11.2 Layout Guidelines

A minimum of four layers is required to accomplish a low EMI PCB design (see [Figure 20](#)). Layer stacking should be in the following order (top-to-bottom): high-speed signal layer, ground plane, power plane and low-frequency signal layer.

- Routing the high-speed traces on the top layer avoids the use of vias (and the introduction of their inductances) and allows for clean interconnects between the isolator and the transmitter and receiver circuits of the data link.
- Placing a solid ground plane next to the high-speed signal layer establishes controlled impedance for transmission line interconnects and provides an excellent low-inductance path for the return current flow.
- Placing the power plane next to the ground plane creates additional high-frequency bypass capacitance of approximately 100pF/in<sup>2</sup>.
- Routing the slower speed control signals on the bottom layer allows for greater flexibility as these signal links usually have margin to tolerate discontinuities such as vias.

If an additional supply voltage plane or signal layer is needed, add a second power / ground plane system to the stack to keep it symmetrical. This makes the stack mechanically stable and prevents it from warping. Also the power and ground plane of each power system can be placed closer together, thus increasing the high-frequency bypass capacitance significantly.

For detailed layout recommendations, see Application Note [SLLA284](#), *Digital Isolator Design Guide*.

### 11.3 Layout Example

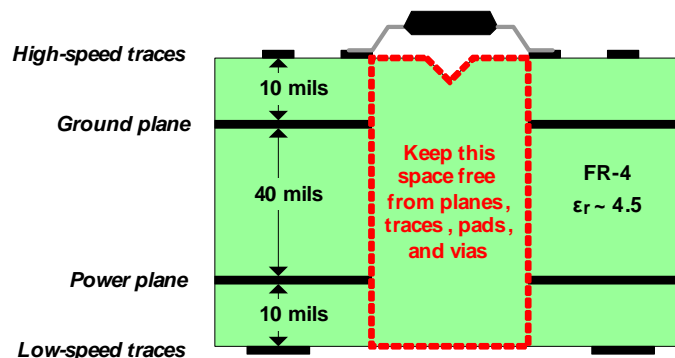

**Figure 20. Recommended Layer Stack**

## 12 Device and Documentation Support

### 12.1 Related Links

The table below lists quick access links. Categories include technical documents, support and community resources, tools and software, and quick access to sample or buy.

**Table 3. Related Links**

PARTS	PRODUCT FOLDER	SAMPLE & BUY	TECHNICAL DOCUMENTS	TOOLS & SOFTWARE	SUPPORT & COMMUNITY
ISO7320C	<a href="#">Click here</a>	<a href="#">Click here</a>	<a href="#">Click here</a>	<a href="#">Click here</a>	<a href="#">Click here</a>
ISO7320FC	<a href="#">Click here</a>	<a href="#">Click here</a>	<a href="#">Click here</a>	<a href="#">Click here</a>	<a href="#">Click here</a>
ISO7321C	<a href="#">Click here</a>	<a href="#">Click here</a>	<a href="#">Click here</a>	<a href="#">Click here</a>	<a href="#">Click here</a>
ISO7321FC	<a href="#">Click here</a>	<a href="#">Click here</a>	<a href="#">Click here</a>	<a href="#">Click here</a>	<a href="#">Click here</a>

### 12.2 Trademarks

DeviceNet is a trademark of Texas Instruments.  
All other trademarks are the property of their respective owners.

### 12.3 Electrostatic Discharge Caution



These devices have limited built-in ESD protection. The leads should be shorted together or the device placed in conductive foam during storage or handling to prevent electrostatic damage to the MOS gates.

### 12.4 Glossary

[SLYZ022](#) — *TI Glossary*.

This glossary lists and explains terms, acronyms, and definitions.

*Isolation Glossary*, [SLLA353](#)

## 13 Mechanical, Packaging, and Orderable Information

The following pages include mechanical packaging and orderable information. This information is the most current data available for the designated devices. This data is subject to change without notice and revision of this document. For browser-based versions of this data sheet, refer to the left-hand navigation.

# D0008B



# PACKAGE OUTLINE

## SOIC - 1.75 mm max height

SOIC

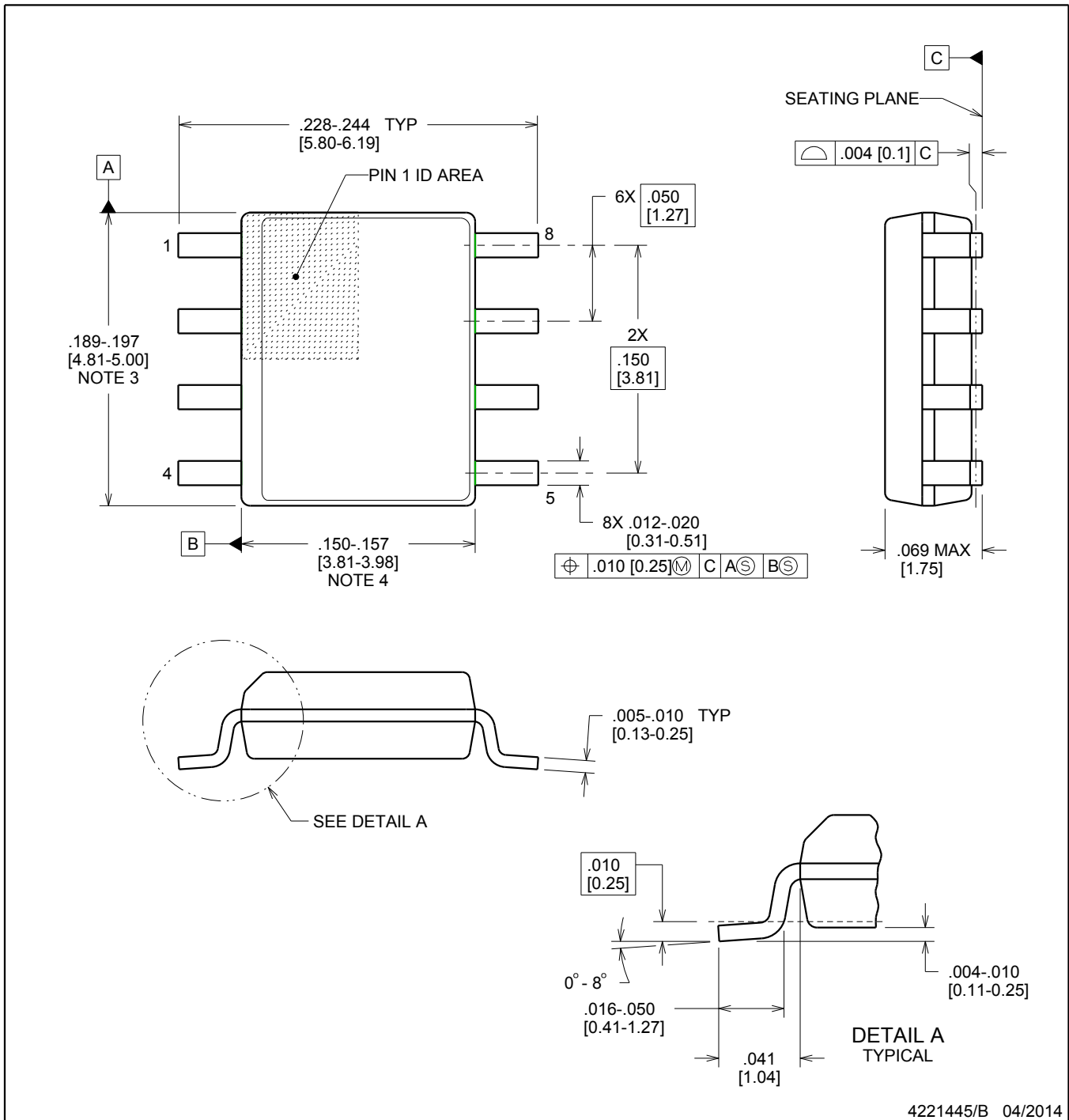

4221445/B 04/2014

### NOTES:

- Linear dimensions are in inches [millimeters]. Dimensions in parenthesis are for reference only. Controlling dimensions are in inches. Dimensioning and tolerancing per ASME Y14.5M.
- This drawing is subject to change without notice.
- This dimension does not include mold flash, protrusions, or gate burrs. Mold flash, protrusions, or gate burrs shall not exceed  $.006$  [0.15], per side.
- This dimension does not include interlead flash.
- Reference JEDEC registration MS-012, variation AA.

# EXAMPLE BOARD LAYOUT

D0008B

SOIC - 1.75 mm max height

SOIC

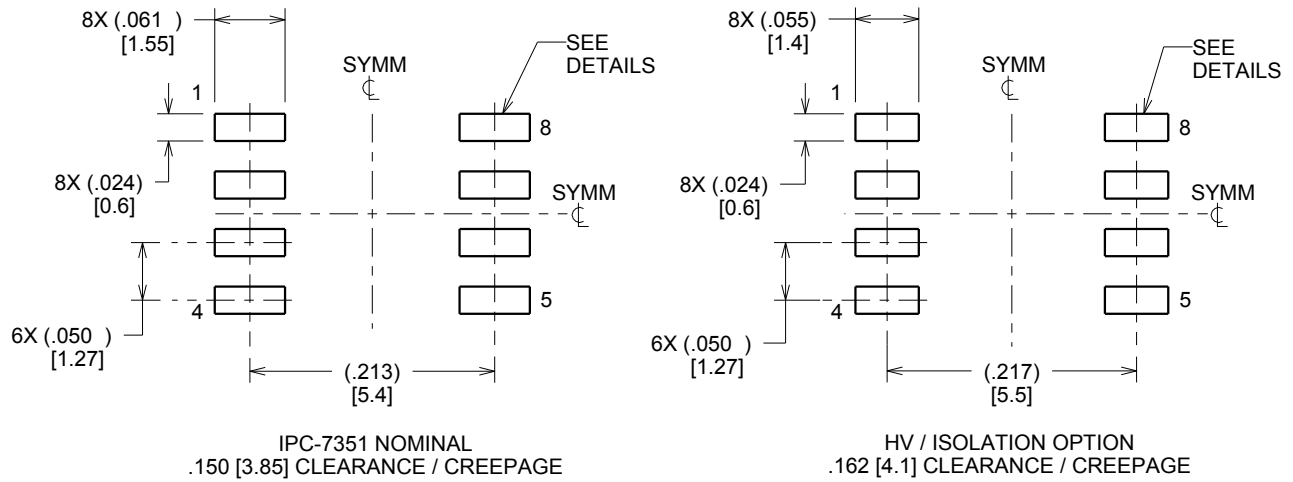

LAND PATTERN EXAMPLE  
SCALE:6X

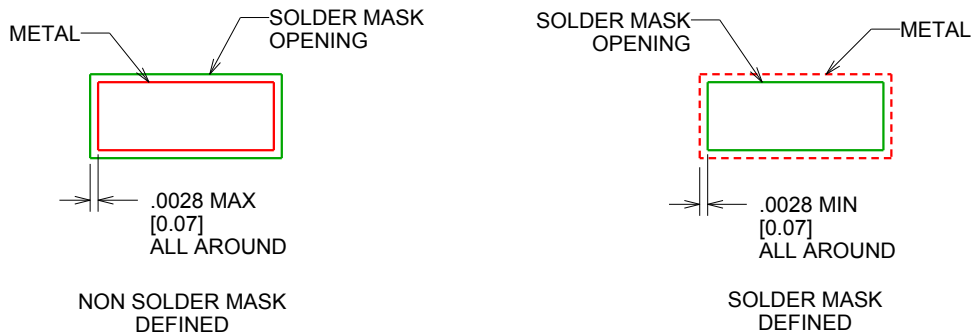

SOLDER MASK DETAILS

4221445/B 04/2014

NOTES: (continued)

- 6. Publication IPC-7351 may have alternate designs.
- 7. Solder mask tolerances between and around signal pads can vary based on board fabrication site.

# EXAMPLE STENCIL DESIGN

D0008B

SOIC - 1.75 mm max height

SOIC

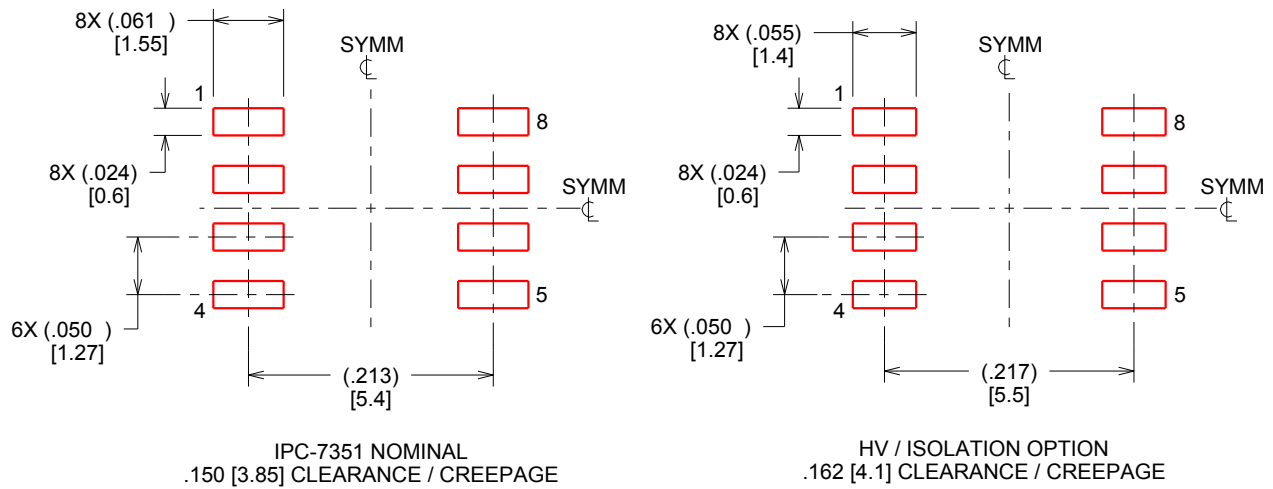

SOLDER PASTE EXAMPLE  
BASED ON .005 INCH [0.127 MM] THICK STENCIL  
SCALE:6X

4221445/B 04/2014

NOTES: (continued)

8. Laser cutting apertures with trapezoidal walls and rounded corners may offer better paste release. IPC-7525 may have alternate design recommendations.
9. Board assembly site may have different recommendations for stencil design.

**PACKAGING INFORMATION**

Orderable Device	Status (1)	Package Type	Package Drawing	Pins	Package Qty	Eco Plan (2)	Lead finish/ Ball material (6)	MSL Peak Temp (3)	Op Temp (°C)	Device Marking (4/5)	Samples
ISO7320CD	ACTIVE	SOIC	D	8	75	RoHS & Green	NIPDAU	Level-2-260C-1 YEAR	-40 to 125	7320C	<a href="#">Samples</a>
ISO7320CDR	ACTIVE	SOIC	D	8	2500	RoHS & Green	NIPDAU	Level-2-260C-1 YEAR	-40 to 125	7320C	<a href="#">Samples</a>
ISO7320FCD	ACTIVE	SOIC	D	8	75	RoHS & Green	NIPDAU	Level-2-260C-1 YEAR	-40 to 125	7320FC	<a href="#">Samples</a>
ISO7320FCDR	ACTIVE	SOIC	D	8	2500	RoHS & Green	NIPDAU	Level-2-260C-1 YEAR	-40 to 125	7320FC	<a href="#">Samples</a>
ISO7321CD	ACTIVE	SOIC	D	8	75	RoHS & Green	NIPDAU	Level-2-260C-1 YEAR	-40 to 125	7321C	<a href="#">Samples</a>
ISO7321CDR	ACTIVE	SOIC	D	8	2500	RoHS & Green	NIPDAU	Level-2-260C-1 YEAR	-40 to 125	7321C	<a href="#">Samples</a>
ISO7321FCD	ACTIVE	SOIC	D	8	75	RoHS & Green	NIPDAU	Level-2-260C-1 YEAR	-40 to 125	7321FC	<a href="#">Samples</a>
ISO7321FCDR	ACTIVE	SOIC	D	8	2500	RoHS & Green	NIPDAU	Level-2-260C-1 YEAR	-40 to 125	7321FC	<a href="#">Samples</a>

(1) The marketing status values are defined as follows:

**ACTIVE:** Product device recommended for new designs.

**LIFEBUY:** TI has announced that the device will be discontinued, and a lifetime-buy period is in effect.

**NRND:** Not recommended for new designs. Device is in production to support existing customers, but TI does not recommend using this part in a new design.

**PREVIEW:** Device has been announced but is not in production. Samples may or may not be available.

**OBSELETE:** TI has discontinued the production of the device.

(2) **RoHS:** TI defines "RoHS" to mean semiconductor products that are compliant with the current EU RoHS requirements for all 10 RoHS substances, including the requirement that RoHS substance do not exceed 0.1% by weight in homogeneous materials. Where designed to be soldered at high temperatures, "RoHS" products are suitable for use in specified lead-free processes. TI may reference these types of products as "Pb-Free".

**RoHS Exempt:** TI defines "RoHS Exempt" to mean products that contain lead but are compliant with EU RoHS pursuant to a specific EU RoHS exemption.

**Green:** TI defines "Green" to mean the content of Chlorine (Cl) and Bromine (Br) based flame retardants meet JS709B low halogen requirements of <=1000ppm threshold. Antimony trioxide based flame retardants must also meet the <=1000ppm threshold requirement.

(3) MSL, Peak Temp. - The Moisture Sensitivity Level rating according to the JEDEC industry standard classifications, and peak solder temperature.

(4) There may be additional marking, which relates to the logo, the lot trace code information, or the environmental category on the device.

(5) Multiple Device Markings will be inside parentheses. Only one Device Marking contained in parentheses and separated by a "~" will appear on a device. If a line is indented then it is a continuation of the previous line and the two combined represent the entire Device Marking for that device.

<sup>(6)</sup> Lead finish/Ball material - Orderable Devices may have multiple material finish options. Finish options are separated by a vertical ruled line. Lead finish/Ball material values may wrap to two lines if the finish value exceeds the maximum column width.

**Important Information and Disclaimer:** The information provided on this page represents TI's knowledge and belief as of the date that it is provided. TI bases its knowledge and belief on information provided by third parties, and makes no representation or warranty as to the accuracy of such information. Efforts are underway to better integrate information from third parties. TI has taken and continues to take reasonable steps to provide representative and accurate information but may not have conducted destructive testing or chemical analysis on incoming materials and chemicals. TI and TI suppliers consider certain information to be proprietary, and thus CAS numbers and other limited information may not be available for release.

In no event shall TI's liability arising out of such information exceed the total purchase price of the TI part(s) at issue in this document sold by TI to Customer on an annual basis.

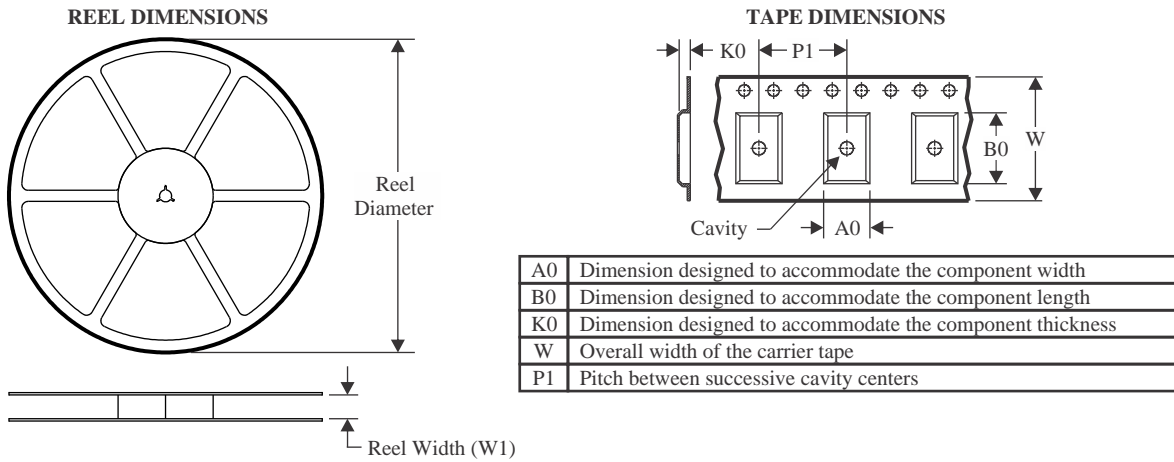
**TAPE AND REEL INFORMATION**

**QUADRANT ASSIGNMENTS FOR PIN 1 ORIENTATION IN TAPE**

\*All dimensions are nominal

Device	Package Type	Package Drawing	Pins	SPQ	Reel Diameter (mm)	Reel Width W1 (mm)	A0 (mm)	B0 (mm)	K0 (mm)	P1 (mm)	W (mm)	Pin1 Quadrant
ISO7320CDR	SOIC	D	8	2500	330.0	12.4	6.4	5.2	2.1	8.0	12.0	Q1
ISO7320FCDR	SOIC	D	8	2500	330.0	12.4	6.4	5.2	2.1	8.0	12.0	Q1
ISO7321CDR	SOIC	D	8	2500	330.0	12.4	6.4	5.2	2.1	8.0	12.0	Q1
ISO7321FCDR	SOIC	D	8	2500	330.0	12.4	6.4	5.2	2.1	8.0	12.0	Q1

**TAPE AND REEL BOX DIMENSIONS**

\*All dimensions are nominal

Device	Package Type	Package Drawing	Pins	SPQ	Length (mm)	Width (mm)	Height (mm)
ISO7320CDR	SOIC	D	8	2500	350.0	350.0	43.0
ISO7320FCDR	SOIC	D	8	2500	350.0	350.0	43.0
ISO7321CDR	SOIC	D	8	2500	350.0	350.0	43.0
ISO7321FCDR	SOIC	D	8	2500	350.0	350.0	43.0

**TUBE**

\*All dimensions are nominal

Device	Package Name	Package Type	Pins	SPQ	L (mm)	W (mm)	T (μm)	B (mm)
ISO7320CD	D	SOIC	8	75	505.46	6.76	3810	4
ISO7320FCD	D	SOIC	8	75	505.46	6.76	3810	4
ISO7321CD	D	SOIC	8	75	505.46	6.76	3810	4
ISO7321FCD	D	SOIC	8	75	505.46	6.76	3810	4

## IMPORTANT NOTICE AND DISCLAIMER

TI PROVIDES TECHNICAL AND RELIABILITY DATA (INCLUDING DATA SHEETS), DESIGN RESOURCES (INCLUDING REFERENCE DESIGNS), APPLICATION OR OTHER DESIGN ADVICE, WEB TOOLS, SAFETY INFORMATION, AND OTHER RESOURCES "AS IS" AND WITH ALL FAULTS, AND DISCLAIMS ALL WARRANTIES, EXPRESS AND IMPLIED, INCLUDING WITHOUT LIMITATION ANY IMPLIED WARRANTIES OF MERCHANTABILITY, FITNESS FOR A PARTICULAR PURPOSE OR NON-INFRINGEMENT OF THIRD PARTY INTELLECTUAL PROPERTY RIGHTS.

These resources are intended for skilled developers designing with TI products. You are solely responsible for (1) selecting the appropriate TI products for your application, (2) designing, validating and testing your application, and (3) ensuring your application meets applicable standards, and any other safety, security, regulatory or other requirements.

These resources are subject to change without notice. TI grants you permission to use these resources only for development of an application that uses the TI products described in the resource. Other reproduction and display of these resources is prohibited. No license is granted to any other TI intellectual property right or to any third party intellectual property right. TI disclaims responsibility for, and you will fully indemnify TI and its representatives against, any claims, damages, costs, losses, and liabilities arising out of your use of these resources.

TI's products are provided subject to [TI's Terms of Sale](#) or other applicable terms available either on [ti.com](https://www.ti.com) or provided in conjunction with such TI products. TI's provision of these resources does not expand or otherwise alter TI's applicable warranties or warranty disclaimers for TI products.

TI objects to and rejects any additional or different terms you may have proposed.

Mailing Address: Texas Instruments, Post Office Box 655303, Dallas, Texas 75265  
Copyright © 2023, Texas Instruments Incorporated

## Looking for pricing, stock, or lifecycle information?

Click below to explore more details on WIN SOURCE:

 [View MAX921CPA on WIN SOURCE](#)

 [Maxim Integrated](#) Information

## Optimize Your Supply Chain with WIN SOURCE Solutions

-  Global Sourcing Solution
-  Obsolete Management
-  Cost Control Management
-  Shortage Management
-  Alternative Solution
-  Excess Inventory Management