



**THE DATASHEET OF  
MB39A134PFT-G-BNDE1**



## DC/DC Converter IC for Charging Li-ion Battery

### Description

The MB39A134 is a DC/DC converter IC for charging Li-ion battery, which is suitable for down conversion, and uses pulse width modulation (PWM) for controlling the charge voltage and current independently.

MB39A134 has a AC adapter detection comparator independent of the DC/DC converter controller, and can control the source of power supply to a system. It supports a wide input voltage range, enables low current consumption in standby mode, and can control the charge voltage and charge current with high precision, which is perfect for the built-in Li-ion battery charger used in devices such as notebook PC.

### Features

- Support 2, 3 and 4 Cell Battery Pack
- Built-in two constant current control loops
- Built-in AC adapter detection function (ACOK pin)
- Charge voltage accuracy :  $\pm 0.7\%$  ( $T_a = -10^\circ\text{C}$  to  $+85^\circ\text{C}$ )
- Built-in charging voltage control without external setting resistor (4.20 V/Cell or 4.10 V/Cell)  
Adjustable to charge voltage with external resistor
- Built-in two high accurate current detection amplifiers ( $\pm 1\%$ ) (At input voltage difference 100 mV)  
( $\pm 5\%$ ) (At input voltage difference 20 mV)  
Input offset voltage: 0 mV (Current Amp1)  
: +3 mV (Current Amp2)
- Built-in Charging Current Control without external resistor ( $R_S = 20\text{ m}\Omega$  : 2.85 A)  
Adjustable charging current with external resistor
- Setting of switching frequency using an external resistor  
(Frequency setting capacitor integrated) : 100 kHz to 2 MHz
- Built-in under voltage lockout protection
- In standby mode ( $I_{CC} = 6\ \mu\text{A}$  Typ) , only AC adapter detection function is operated
- Built-in VH regulator for reducing Qg loss of P-ch MOS FET
- Package : TSSOP-24

### Applications

- Built-in charger for Notebook PC
- Handy terminal device etc.

**Contents**

<b>Description .....</b>	<b>1</b>	10. Connection Without Using The Current Amp1, Current	
<b>Features .....</b>	<b>1</b>	Amp2 And The Error Amp1, Error Amp2 .....	22
<b>Applications .....</b>	<b>1</b>	11. Input/Output Pin Equivalent Circuit Diagram .....	23
1. Pin Assignment .....	3	12. Typical Application Circuit .....	26
2. Pin Descriptions .....	4	13. Application Note .....	30
3. Block Diagram .....	5	14. Reference Data .....	39
4. Absolute Maximum Ratings .....	6	15. Usage Precaution .....	41
5. Recommended Operating Conditions .....	7	16. Ordering Information .....	41
6. Electrical Characteristics .....	8	17. RoHS Compliance Information .....	41
7. Typical Characteristics .....	12	18. Package Dimension .....	42
8. Functional Description .....	14	19. Document History .....	43
8.1 DC/DC Converter Block .....	14	<b>Sales, Solutions, and Legal Information .....</b>	<b>44</b>
8.2 Protection Functions .....	16		
9. Transit Response When A Load Changes Suddenly .....	21		

## 1. Pin Assignment

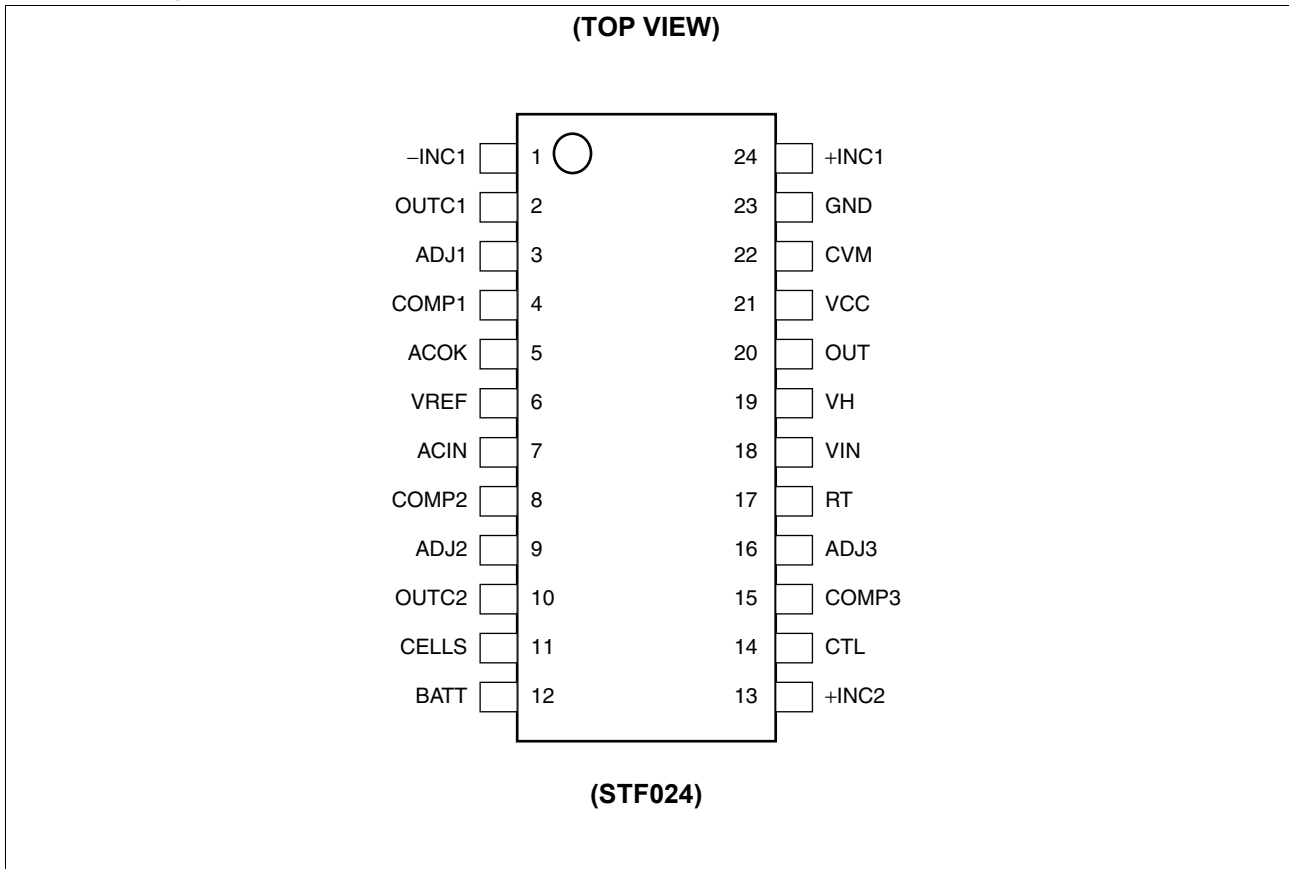

## 2. Pin Descriptions

Pin No.	Pin Name	I/O	Description
1	-INC1	I	Current detection amplifier (Current Amp1) inverted input pin.
2	OUTC1	O	Current detection amplifier (Current Amp1) output pin.
3	ADJ1	I	Error amplifier (Error Amp1) non-inverted input pin.
4	COMP1	O	Error amplifier (Error Amp1) output pin.
5	ACOK	O	AC adapter voltage detection block (AC Comp.) output pin. ACIN = H : ACOK = L, ACIN = L : ACOK = Hi-Z
6	VREF	O	Reference voltage output pin.
7	ACIN	I	AC adapter voltage detection block (AC Comp.) input pin.
8	COMP2	O	Error amplifier (Error Amp2) output pin.
9	ADJ2	I	Charge current control block setting input pin. ADJ2 pin "GND to 4.4 V" : Charge current control block output = ADJ2 pin voltage ADJ2 pin "4.6 V to VREF" : Charge current control block output = 1.5 V
10	OUTC2	O	Current detection amplifier (Current Amp2) output pin.
11	CELLS	I	Charge voltage setting switch pin (2 or 3 or 4 Cells). CELLS = VREF: 4 Cells, CELLS = GND: 3 Cells, CELLS = OPEN: 2 Cells
12	BATT	I	Current detection amplifier (Current Amp2) inverted input pin. Battery voltage input pin.
13	+INC2	I	Current detection amplifier (Current Amp2) non-inverted input pin.
14	CTL	I	Power supply control pin. Setting the CTL pin at "H" level places the DC/DC converter IC in the operating mode. Setting the CTL pin at "L" level places the DC/DC converter IC in the standby mode.
15	COMP3	O	Error amplifier (Error Amp3) output pin.
16	ADJ3	I	Charge voltage control block setting input pin. ADJ3 pin "GND to 0.2 V" : Charge voltage setting 4.10 V/Cell ADJ3 pin "0.4 V to 4.4 V" : Charge voltage setting $2 \times V_{ADJ3}$ pin voltage/Cell ADJ3 pin "4.6 V to VREF" : Charge voltage setting 4.20 V/Cell
17	RT	–	Triangular wave oscillation frequency setting resistor connection pin.
18	VIN	–	Power supply pin for ACOK function block.
19	VH	O	Power supply pin for FET drive circuit (VH = VCC – 6 V)
20	OUT	O	External FET gate drive pin.
21	VCC	–	Power supply pin for reference voltage , control circuit, and output circuit.
22	CVM	O	Constant voltage control state detection block (CV Comp.) output pin.
23	GND	–	Ground pin.
24	+INC1	I	Current detection amplifier (Current Amp1) non-inverted input pin.

### 3. Block Diagram

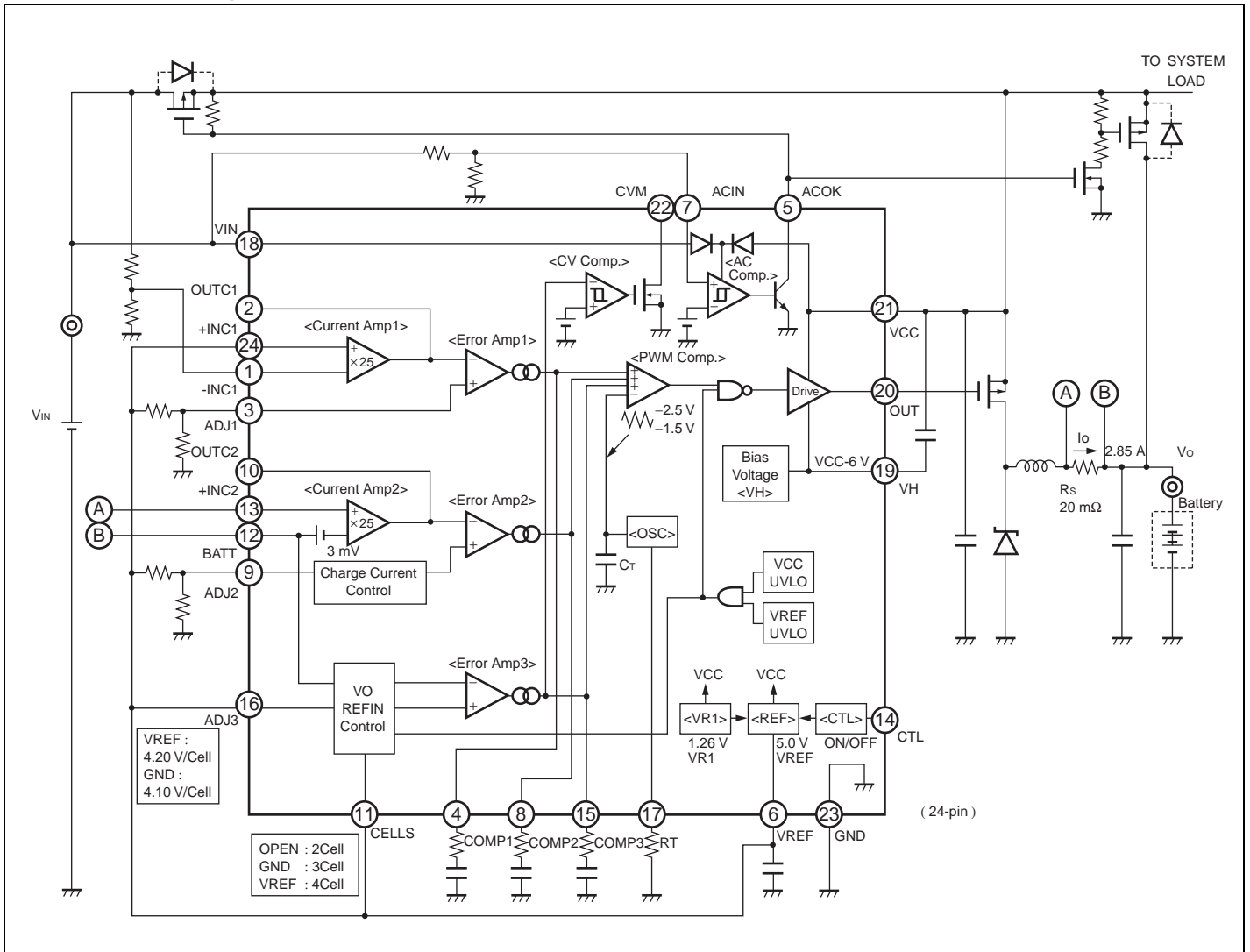

#### 4. Absolute Maximum Ratings

Parameter	Symbol	Condition	Rating		Unit
			Min	Max	
Power supply voltage	V <sub>VCC</sub>	VCC, VIN pin	- 0.3	+ 28	V
		VCC, VIN pin, t ≤ 10 μs	- 0.3	+ 32	V
Output current	I <sub>OUT</sub>	OUT pin	- 60	+ 60	mA
		OUT pin Duty ≤ 5% (t = 1/fosc × Duty)	- 700	+ 700	mA
CLT pin input voltage	V <sub>CTL</sub>	CTL pin	- 0.3	+ 28	V
Input voltage	V <sub>INE</sub>	ADJ1, ADJ2, ADJ3, CELLS, ACIN pin	- 0.3	V <sub>VREF</sub> + 0.3	V
	V <sub>INC</sub>	-INC1, +INC1, BATT, +INC2 pin	- 0.3	+ 28	V
Power dissipation	P <sub>D</sub>	Ta ≤ + 25°	-	1282* <sup>1,*2</sup>	mW
		Ta = + 85°	-	512* <sup>1,*2</sup>	mW
Storage temperature	T <sub>STG</sub>	-	- 55	+ 125	°C

\*1 : See the diagram of “Typical Characteristics. Maximum Power Dissipation vs. Operating Ambient Temperature”, for the package power dissipation of Ta from + 25° C to + 85° C.

\*2 : When IC is mounted on a 10x10 cm two-layer square epoxy board.

**WARNING:** Semiconductor devices can be permanently damaged by application of stress (voltage, current, temperature, etc.) in excess of absolute maximum ratings. Do not exceed these ratings.

## 5. Recommended Operating Conditions

Parameter	Symbol	Condition	Value			Unit
			Min	Typ	Max	
Power supply voltage	$V_{VCC}$	VCC, VIN pin	8	—	25	V
Reference voltage output current	$I_{VREF}$	—	−1	—	0	mA
VH pin output current	$I_{VH}$	—	0	—	30	mA
Input voltage	$V_{INE}$	ADJ1 pin	0	—	$V_{VREF} - 1.5$	V
		ADJ2 pin (internal reference voltage setting)	4.6	—	$V_{VREF}$	V
		ADJ2 pin (external voltage setting)	0	—	4.4	V
		ADJ3 pin (internal reference voltage setting)	0	—	0.2	V
			4.6	—	$V_{VREF}$	V
		ADJ3 pin (external voltage setting)	0.4	—	4.4	V
	CELLS pin	0	—	$V_{VREF}$	V	
$V_{INC}$	+INC1, +INC2, -INC1, BATT pin	0	—	$V_{VCC}$	V	
ACIN pin input voltage	$V_{ACIN}$	—	0	—	5	V
ACOK pin output voltage	$V_{ACOK}$	—	0	—	25	V
ACOK pin output current	$I_{ACOK}$	—	0	—	1	mA
CTL pin input voltage	$V_{CTL}$	—	0	—	25	V
Output current	$I_{OUT}$	OUT pin	−45	—	+ 45	mA
		OUT pin Duty $\leq 5\%$ ( $t = 1 / f_{osc} \times \text{Duty}$ )	−600	—	+ 600	mA
Switching frequency	$f_{OSC}$	—	100	500	2000	kHz
Timing resistor	$R_{RT}$	RT pin	8.2	33	180	k $\Omega$
VH pin capacitor	$C_{VH}$	—	—	0.1	1.0	$\mu\text{F}$
Reference voltage output capacitor	$C_{VREF}$	VREF pin	—	0.1	1.0	$\mu\text{F}$
Operating ambient temperature	$T_a$	—	−30	+ 25	+ 85	$^{\circ}\text{C}$

**WARNING:** The recommended operating conditions are required in order to ensure the normal operation of the semiconductor device. All of the device's electrical characteristics are warranted when the device is operated within these ranges.

Always use semiconductor devices within their recommended operating condition ranges. Operation outside these ranges may adversely affect reliability and could result in device failure.

No warranty is made with respect to uses, operating conditions, or combinations not represented on the data sheet. Users considering application outside the listed conditions are advised to contact their representatives beforehand.

## 6. Electrical Characteristics

(Ta = +25°, VCC pin = 19 V, VREF pin = 0 mA)

Parameter		Symbol	Pin No.	Condition	Value			Unit
					Min	Typ	Max	
Reference Voltage Block [REF]	Threshold voltage	$V_{VREF1}$	6	—	4.963	5.000	5.037	V
		$V_{VREF2}$	6	Ta = -10° to +85°	4.950	5.000	5.050	V
	Input stability	VREF Line	6	VCC pin = 8 V to 25 V	—	3	10	mV
	Load stability	VREF Load	6	VREF pin = 0 mA to -1 mA	—	1	10	mV
	Short-circuit output current	I <sub>os</sub>	6	VREF pin = 1 V	-25	-12	-6	mA
Triangular Wave Oscillator Block [OSC]	Switching frequency	f <sub>OSC</sub>	20	RT pin = 33 kΩ	450	500	550	kHz
	Frequency temperature variation	df/fdT	20	Ta = -30° to +85°	—	1*	—	%
Error Amplifier Block [Error Amp1]	Input offset voltage	V <sub>IO</sub>	2, 3	COMP1 pin = 2 V	—	1	5	mV
	Input bias voltage	I <sub>ADJ1</sub>	3	ADJ1 pin = 0 V	-100	—	—	nA
	Transconductance	G <sub>m</sub>	15	—	—	20*	—	μA/V
Error Amplifier Block [Error Amp2]	Threshold voltage	V <sub>TH1</sub>	10	ADJ2 pin = VREF pin	—	1.5*	—	V
	Transconductance	G <sub>m</sub>	15	—	—	20*	—	μA/V
Error Amplifier Block [Error Amp3]	Threshold voltage accuracy	V <sub>TH1</sub>	12	COMP3 pin = 2 V, Ta = +25° ADJ3 pin = VREF pin (4.20 V/Cell setting)	-0.5	0	+ 0.5	%
		V <sub>TH2</sub>	12	COMP3 pin = 2 V, Ta = -10° to +85°, ADJ3 pin = VREF pin (4.20 V/Cell setting)	-0.7	0	+ 0.7	%
		V <sub>TH3</sub>	12	COMP3 pin = 2 V, Ta = +25° ADJ3 pin = GND, (4.10 V/Cell setting)	-0.6	0	+ 0.6	%
		V <sub>TH4</sub>	12	COMP3 pin = 2 V, Ta = -10° to +85° ADJ3 pin = GND, (4.10 V/Cell setting)	-0.8	0	+ 0.8	%

(Ta = +25°, VCC pin = 19 V, VREF pin = 0 mA)

Parameter		Symbol	Pin No.	Condition	Value			Unit
					Min	Typ	Max	
Error Amplifier Block [Error Amp3]	Input current	I <sub>BATTH1</sub>	12	ADJ3 pin = CELLS pin = VREF pin BATT pin = 16.8 V	–	25.2	38	μA
		I <sub>BATTL</sub>	12	VCC pin = 0 V, BATT pin = 16.8 V	–	0	1	μA
	Transconductance	G <sub>m</sub>	15	–	–	30*	–	μA/V
Current Detection Amplifier Block [Current Amp1, Current Amp2]	Input current	I <sub>+INCH</sub>	13, 24	+INC1 pin = +INC2 pin = 3 V to VCC pin, ΔVin = –100 mV	–	20	30	μA
		I <sub>–INCH</sub>	1	+INC1 pin = 3 V to VCC pin, ΔVin = –100 mV	–	0.1	0.2	μA
		I <sub>+INCL</sub>	13, 24	+INC1 pin = +INC2 pin = 0.1 V, ΔVin = –100 mV	–225	–150	–	μA
		I <sub>–INCL</sub>	1	+INC1 pin = +INC2 pin = 0.1 V, ΔVin = –100 mV	–255	–170	–	μA
	Input offset voltage	V <sub>OFF1</sub>	2	+INC1 pin = 3 V to VCC pin	–1	0	1	mV
		V <sub>OFF2</sub>	10	+INC2 pin = 3 V to VCC pin	2	3	4	mV
		V <sub>OFF3</sub>	10	+INC2 pin = 0 V to 3 V	1	3	5	mV
	Common mode input voltage range	V <sub>CM</sub>	2, 10	–	0	–	V <sub>VCC</sub>	V
	Voltage gain	A <sub>V</sub>	2, 10	+INC1 pin = +INC2 pin = 3 V to VCC pin, ΔVin = –100 mV	24.5	25.0	25.5	V/V
	Frequency band width	BW	2, 10	A <sub>V</sub> = 0 dB	–	2*	–	MHz
	Output voltage	V <sub>OUTCH1</sub>	2	–	4.7	4.9	–	V
		V <sub>OUTCH2</sub>	10	–	4.5	4.7	–	V
		V <sub>OUTCL</sub>	2, 10	–	50	75	100	mV
	Output source current	I <sub>SOURCE</sub>	2, 10	OUTC1 pin = OUTC2 pin = 2 V	–	–2	–1	mA
Output sink current	I <sub>SINK</sub>	2, 10	OUTC1 pin = OUTC2 pin = 2 V	150	300	–	μA	
PWM Comp. Block [PWM Comp.]	Threshold voltage	V <sub>TL</sub>	20	Duty cycle = 0%	1.4	1.5	–	V
		V <sub>TH</sub>	20	Duty cycle = 100%	–	2.5	2.6	V

(Ta = +25°, VCC pin = 19 V, VREF pin = 0 mA)

Parameter		Symbol	Pin No.	Condition	Value			Unit
					Min.	Typ.	Max.	
Output Block [OUT]	Output source current	$I_{SOURCE}$	20	OUT pin = 13 V, Duty $\leq$ 5% (t = 1/fosc $\infty$ Duty)	–	–400*	–	mA
	Output sink current	$I_{SINK}$	20	OUT pin = 19V, Duty $\leq$ 5% (t = 1/fosc $\infty$ Duty)	–	400*	–	mA
	Output ON resistance	$R_{OH}$	20	OUT pin = –45 mA	–	6.5	9.8	$\Omega$
		$R_{OL}$	20	OUT pin = 45 mA	–	5.0	7.5	$\Omega$
	Rise time	tr1	20	OUT pin = 3300 pF	–	50*	–	ns
Fall time	tf1	20	OUT pin = 3300 pF	–	50*	–	ns	
Control Block [CTL]	CTL input voltage	$V_{ON}$	14	IC operation mode	2	(	25	V
		$V_{OFF}$	14	IC standby mode	0	(	0.8	V
	Input current	$I_{CTLH}$	14	CTL pin = 5 V	–	100	150	$\mu$ A
		$I_{CTLL}$	14	CTL pin = 0 V	–	0	1	$\mu$ A
Bias Voltage Block [VH]	Output voltage	$V_H$	19	VCC pin = 8 V to 25 V, VH pin = 0 to 30 mA	$V_{VCC}^-$ 6.5	$V_{VCC}^-$ 6.0	$V_{VCC}^-$ 5.5	V
Under Voltage Lockout Protection Circuit Block [UVLO]	Threshold voltage	$V_{TLH}$	21	VCC pin = $\uparrow$	6.0	6.2	6.4	V
		$V_{THL}$	21	VCC pin = $\downarrow$	5.0	5.2	5.4	V
	Hysteresis width	$V_H$	21	VCC pin	–	1.0*	–	V
	Threshold voltage	$V_{TLH}$	6	VREF pin = $\uparrow$	2.6	2.8	3.0	V
		$V_{THL}$	6	VREF pin = $\downarrow$	2.4	2.6	2.8	V
Hysteresis width	$V_H$	6	VREF pin	–	0.2	–	V	
Over Temperature Detection	Detection temperature	$T_{TH}$	20	–	–	+ 150	–	°C
	Release temperature	$T_{TL}$	20	–	–	+ 125	–	°C
AC Adapter Voltage Detection Block [AC Comp.]	Threshold voltage	$V_{TLH}$	7	–	1.245	1.270	1.295	V
		$V_{THL}$	7	–	1.215	1.250	1.285	V
	Hysteresis width	$V_H$	7	–	–	20	–	mV
	ACOK pin output leak current	$I_{LEAK}$	5	ACOK pin = 25 V	–	0	1	$\mu$ A
	ACOK pin output “L” level voltage	$V_{ACOKL}$	5	ACOK pin = 1 mA	–	0.9	1.1	V
	Current consumption	$I_{VINL}$	18	VIN pin = 19 V, ACIN pin = 0 V	–	0	1	$\mu$ A
$I_{VINH}$		18	VIN pin = 19 V, ACIN pin = 5 V	–	6	10	$\mu$ A	

(Ta = +25°, VCC pin = 19 V, VREF pin = 0 mA)

Parameter		Symbol	Pin No.	Condition	Value			Unit
					Min.	Typ.	Max.	
Charge Voltage Control Block [VO REF IN Control]	Input voltage	V <sub>H</sub>	16	At 4.20 V/Cell	4.6	—	V <sub>VREF</sub>	V
		V <sub>EXT</sub>	16	At external setting	0.4	—	4.4	V
		V <sub>L</sub>	16	At 4.10 V/Cell	0	—	0.2	V
	Threshold voltage	V <sub>TL</sub>	16	—	0.21	0.3	0.39	V
		V <sub>TH</sub>	16	—	4.41	4.5	4.59	V
	Input current	I <sub>IN</sub>	16	ADJ3 pin	—	0	1	μA
	Input voltage	V <sub>H</sub>	11	At 4 Cells	V <sub>VREF</sub> - 0.4	—	V <sub>VREF</sub>	V
		V <sub>M</sub>	11	At 2 Cells	2.4	—	2.6	V
		V <sub>L</sub>	11	At 3 Cells	0	—	0.3	V
Input current	I <sub>INL</sub>	11	CELLS = 0 V	-8.3	-5	—	μA	
	I <sub>INH</sub>	11	CELLS = V <sub>VREF</sub>	—	5	8.3	μA	
Charge Current Control Block [Charge Current Control]	Input voltage	V <sub>H</sub>	9	At normal charge	4.6	—	V <sub>VREF</sub>	V
		V <sub>EXT</sub>	9	At external setting	0	—	4.4	V
	Threshold voltage	V <sub>TH</sub>	9	—	4.41	4.50	4.59	V
	Input current	I <sub>IN</sub>	9	ADJ2 pin	—	0	1	μA
General	Standby current	I <sub>CCS1</sub>	18	VCC pin = 0 V, CTL pin = 0 V, ACIN pin = 5 V, VIN pin = 19 V	—	6	10	μA
		I <sub>CCS2</sub>	21	VIN pin = 0 V, CTL pin = 0 V, VCC pin = 19 V	—	0	1	μA
	Power supply current	I <sub>CC</sub>	21	CTL pin = 5 V	—	2.7	4.0	mA

\*: This parameter isn't be specified. This should be used as a reference to support designing the circuits.

## 7. Typical Characteristics

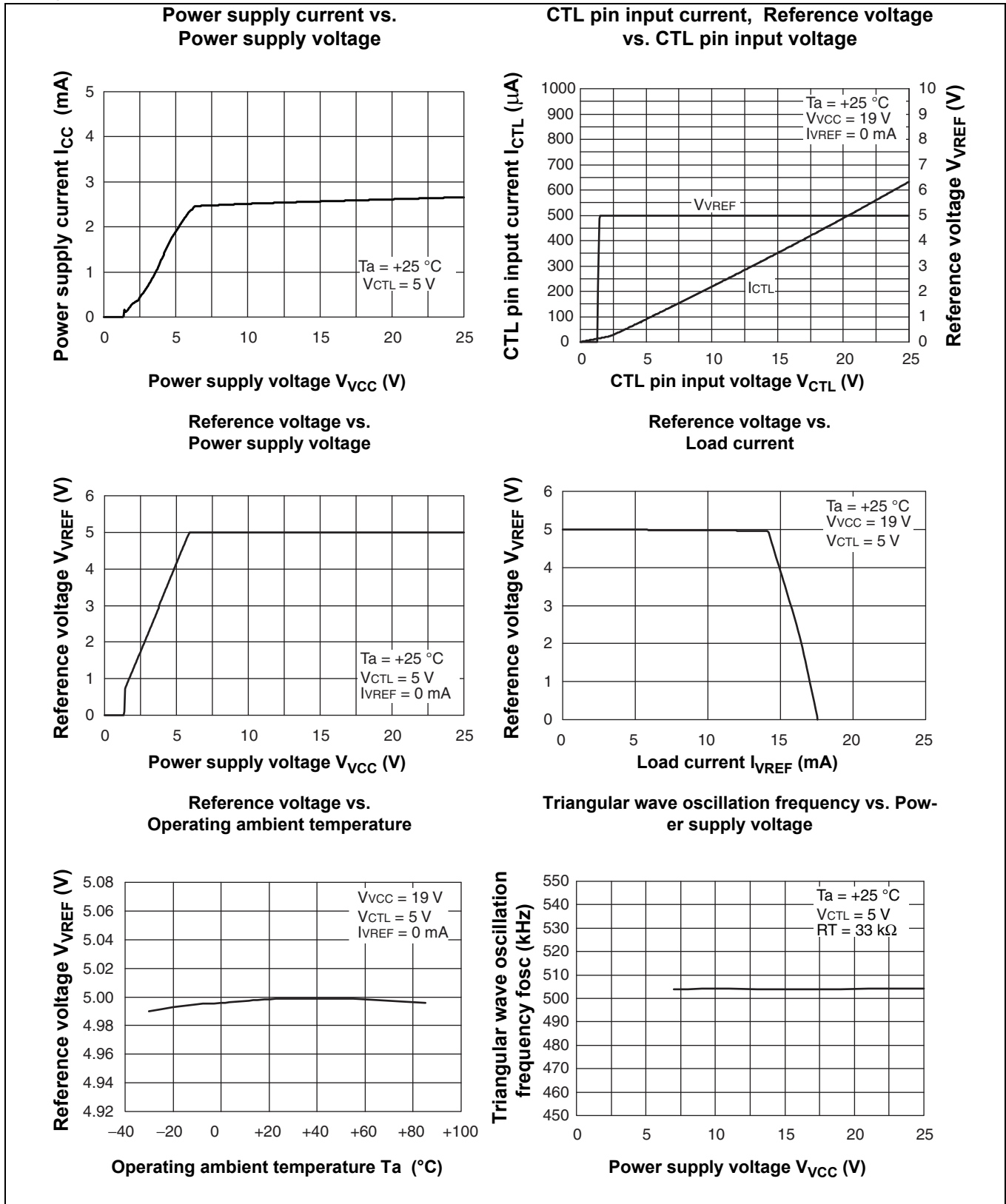

**Triangular wave oscillation frequency vs. Operating ambient temperature**

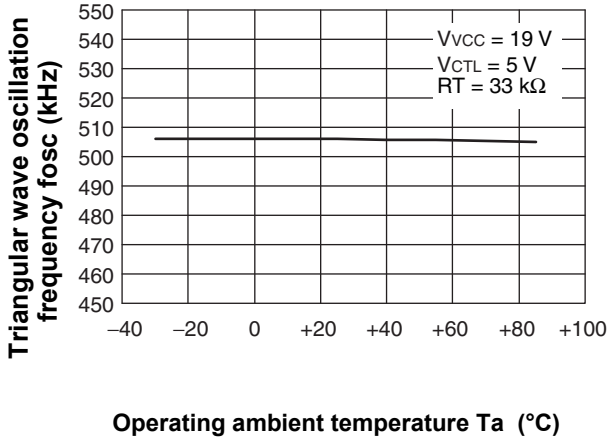

**Triangular wave oscillation frequency vs. Timing resistor**

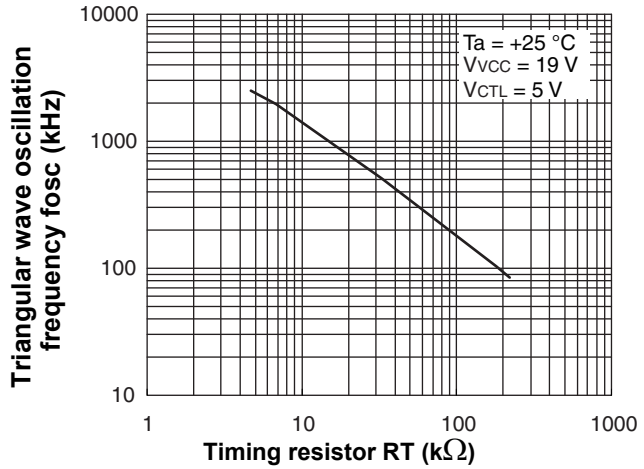

**Operating ambient temperature  $T_a$  (°C)**

**Error amplifier threshold voltage vs. Operating ambient temperature**

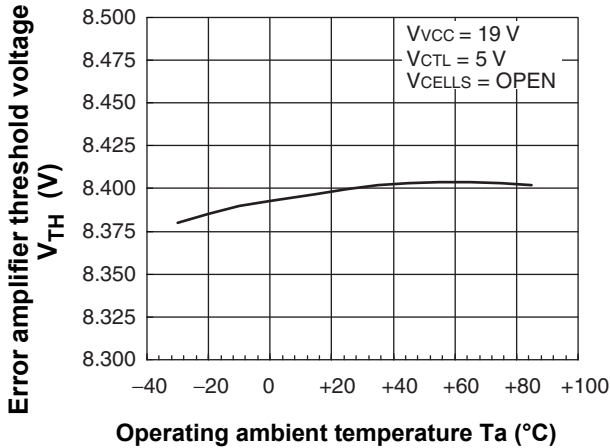

**Error amplifier threshold voltage vs. Operating ambient temperature**

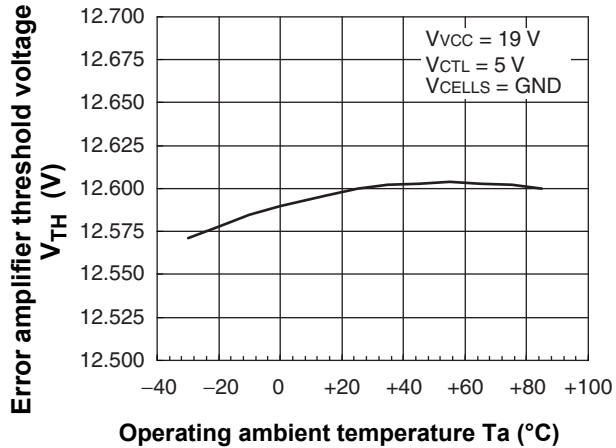

**Error amplifier threshold voltage vs. Operating ambient temperature**

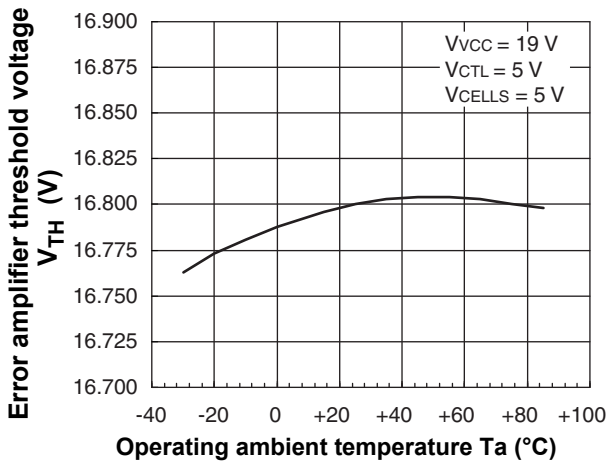

**Permissible dissipation vs. Operating ambient temperature**

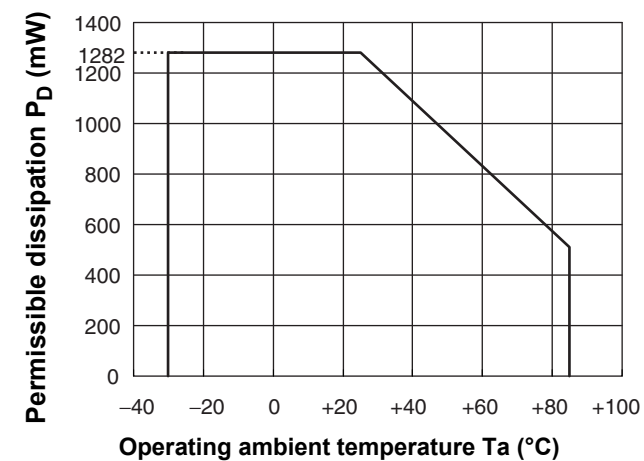

## 8. Functional Description

MB39A134 is a DC/DC converter which uses pulse width modulation (PWM) for charging Li-ion battery and controls the charge voltage and current when charging the battery. It includes the charge control function for the battery and the AC adapter voltage detection function to stably supply the voltage from the AC adapter and the battery to the system.

- When controlling the charge voltage (constant voltage mode), the voltage entered in ADJ3 pin and CELLS pin can be used to set an arbitrary voltage. The error amplifier (Error Amp3) compares BATT pin voltage with the internal reference voltage to generate the PWM control signal for generating an arbitrary charge voltage.
- When controlling the charge current (constant current mode), the current detection amplifier (Current Amp2) amplifies the voltage drop generated between both ends of the charge current sense resistance ( $R_S$ ) to 25 times and outputs it through OUTC2 pin. The error amplifier (Error Amp2) compares the output voltage from the current detection amplifier (Current Amp2) with the voltage set at ADJ2 pin to generate the PWM control signal for executing the constant current charge.
- When controlling the AC adapter power, the current detection amplifier (Current Amp1) amplifies the difference between -INC1 pin voltage and +INC1 pin voltage ( $V_{VREF}$ ) to 25 times and outputs it through OUTC1 pin when the output voltage of the AC adapter drops. The error amplifier (Error Amp1) compares the output voltage from the current detection amplifier (Current Amp1) with ADJ1 pin voltage to generate the PWM control signal for controlling the charge current so that AC adapter power can be kept constant.

The triangular wave voltage generated from the triangular wave oscillator is compared with the lowest potential of the output voltages from the error amplifier (Error Amp1, Error Amp2, and Error Amp3) and when the former is lower than the latter, the high side switching FET is set on.

In addition, AC Comp detects installation/removal of the AC adapter and its information is generated through ACOK pin.

### 8.1 DC/DC Converter Block

#### 8.1.1 Reference Voltage Block (REF)

The reference voltage circuit (REF) uses the voltage supplied from the VCC pin (pin 21) to generate stable voltage (Typ 5.0 V) that has undergone temperature compensation. The generated voltage is used as the reference power supply for the internal circuitry of the IC.

This block can output load current of up to 1 mA from the reference voltage VREF pin (pin 6).

#### 8.1.2 Triangular Wave Oscillator Block (OSC)

The triangular wave oscillator builds the capacitor for frequency setting into, and generates the triangular wave oscillation waveform by connecting the frequency setting resistor with the RT pin (pin 17). The triangular wave is input to the PWM comparator on the IC.

Triangular wave oscillation frequency:  $f_{osc}$

$$f_{osc} \text{ (kHz)} \approx 17000 / RT \text{ (k}\Omega\text{)}$$

#### 8.1.3 Error Amplifier Block (Error Amp1)

This amplifier detects the output signal from the current detection amplifier (Current Amp1) and outputs a PWM control signal.

In addition, a stable phase compensation can be made available to the system by connecting the resistor and the capacitor to the COMP1 pin.

#### 8.1.4 Error Amplifier Block (Error Amp2)

This amplifier detects the output signal from the current detection amplifier (Current Amp2), compares this to the output signal from the charge current control circuit, and outputs a PWM control signal to be used in controlling the charge current.

In addition, a stable phase compensation can be made available to the system by connecting the resistor and the capacitor to the COMP2 pin.

### 8.1.5 Error Amplifier Block (Error Amp3)

This error amplifier (Error Amp3) detects the output voltage from the DC/DC converter, compares this to the output signal from the VO REFIN controller circuit, and outputs the PWM control signal.

Arbitrary output voltage from 2 Cell to 4 Cell can be set by connecting an external resistor of charging voltage to ADJ3 pin (pin 16). In addition, a stable phase compensation can be made available to the system by connecting the resistor and the capacitor to the COMP3 pin.

### 8.1.6 Current Detection Amplifier Block (Current Amp1)

The current detection amplifier (Current Amp1) amplifies the voltage difference between +INC1 pin (pin 24) and -INC1 pin (pin 1) 25 times and the signal is output to the following error amplifier (Error Amp1) .

### 8.1.7 Current Detection Amplifier Block (Current Amp2)

The current detection amplifier (Current Amp2) detects a voltage drop on the both ends of the output sense resistor ( $R_S$ ) due to the flow of the charge current, using the +INC2 pin (pin 13) and BATT pin (pin 12). The signal amplified to 25 times is output to the following error amplifier (Error Amp2).

### 8.1.8 PWM Comparator Block (PWM Comp.)

The PWM comparator circuit (PWM Comp.) is a voltage-pulse width converter for controlling the output duty of the error amplifiers (Error Amp1 to Error Amp3) depending on their output voltage.

The PWM comparator circuit compares the triangular wave voltage generated by the triangular wave oscillator with the error amplifier output voltage and turns on the external output transistor (MOS FET) , during the interval in which the triangular wave voltage is lower than the error amplifier output voltage.

### 8.1.9 Output Block (OUT)

The output circuit uses a totem-pole configuration capable of driving an external P-ch MOS FET.

The output “L” level sets the output amplitude to 6 V (Typ) using the voltage generated by the bias voltage block (VH) .

This results in increasing conversion efficiency and suppressing the withstand voltage of the connected external transistor (MOSFET) even in a wide range of input voltages.

### 8.1.10 Power Supply Control Block (CTL)

Setting the CTL pin (pin 14) to “L” level places the IC in the standby mode. During the standby mode, only AC adapter detection function is operated. (The supply current is 6  $\mu$ A at typical in the standby mode.)

**Table 1. CTL Function Table**

CTL	Power	AC Adapter Detection
L	OFF (Standby)	ON (Active)
H	ON (Active)	ON (Active)

### 8.1.11 Bias Voltage Block (VH)

The bias voltage circuit outputs  $V_{VCC} - 6$  V (Typ) as the minimum potential of the output circuit. In the standby mode, this circuit outputs the potential equal to  $V_{VCC}$ .

## 8.2 Protection Functions

### 8.2.1 Under Voltage Lockout Protection Circuit Block (UVLO)

The transient state or a momentary decrease in supply voltage or internal reference voltage (VREF pin), which occurs when the power supply (VCC pin) is turned on, may cause malfunctions in the control IC, resulting in breakdown or deterioration of the system.

To prevent such malfunction, the under voltage lockout protection circuit detects internal reference voltage drop and fixes the OUT pin (pin 20) to the "H" level. The system restores when the power supply and the internal reference reaches less than the threshold voltage of the lockout protection circuit at the low voltage level.

#### Protection circuit (UVLO) operation function table

When UVLO is operating (VCC or VREF voltage is lower than UVLO threshold voltage.), the logic of the following pin is fixed at the value shown.

pin	OUT
Status	H

### 8.2.2 Over Temperature Detection

The circuit protects an IC from heat-destruction. If the temperature at the joint part reaches +150°C, the circuit changes the level of OUT pin to "H", and stops the voltage output.

In addition, if the temperature at the joint part drops to +125°C, the output restarts again.

Therefore, make sure to design the DC/DC power supply system so that the over heating protection does not start frequently.

### 8.2.3 Detection Functions

#### AC adapter voltage detection block (AC Comp.)

The AC adapter voltage detection block (AC Comp.) detects that ACIN pin voltage is below 1.25 V (Typ) and sets ACOK pin in the AC adapter voltage detection block to Hi-Z. In addition, a higher voltage from either VCC pin or VIN pin is supplied as the IC power supply.

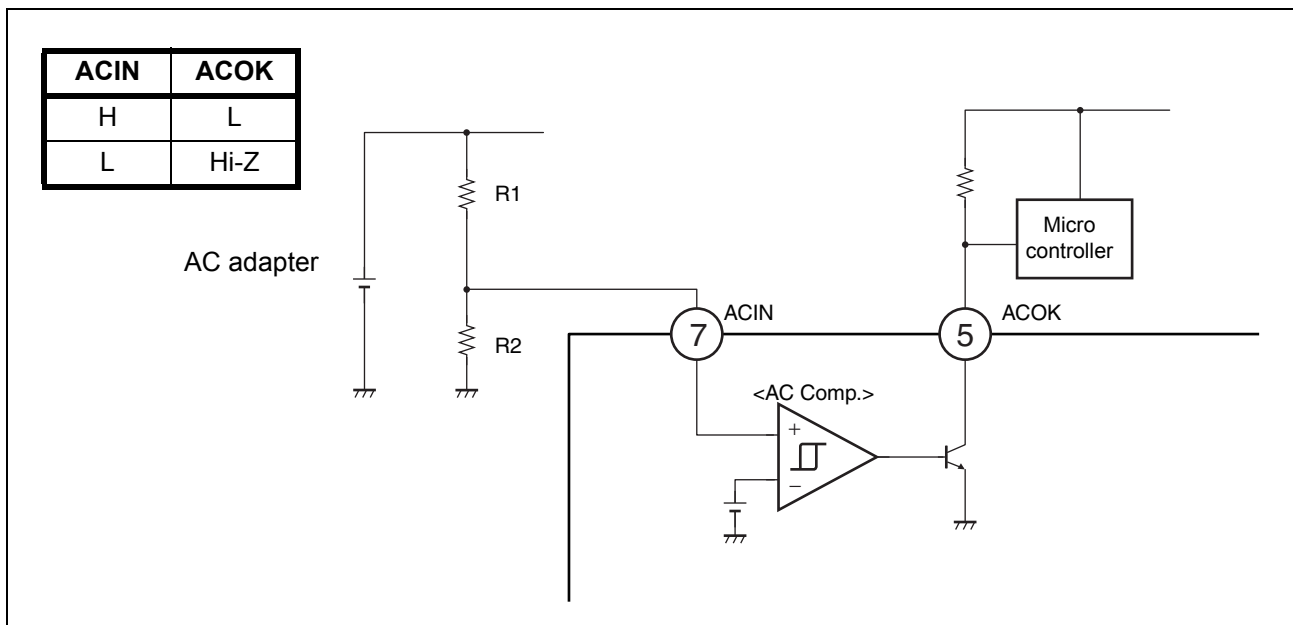

AC adapter detection voltage setting

$V_{IN}$  = Low to High

$$V_{th} = (R1 + R2) / R2 \times 1.27 \text{ V}$$

$V_{IN}$  = High to Low

$$V_{th} = (R1 + R2) / R2 \times 1.25 \text{ V}$$

### 8.2.4 Setting the Charge Voltage

The charge voltage (DC/DC output) is set by the input voltage to ADJ3 pin (pin 16) and CELLS pin (pin 11). The ADJ3 pin (pin 16) can set charge voltage per cell. An arbitrary charge voltage is set when external resistor is set. It does not need external resistor when ADJ3 pin (pin 16) is input to VREF level or GND level by internal high accurate reference voltage. The CELLS pin (pin 11) can set the series battery number when the pin is input VREF, OPEN or GND level.

The setting of ADJ3 pin (pin 16), CELLS pin (pin 11) and charge voltage (DC/DC output) is shown below.

ADJ3 Input Voltage	CELLS	Charge Voltage	Note
VREF pin (ADJ3 $\geq$ 4.6 V)	OPEN	8.4 V	2 Cell $\times$ 4.20 V/Cell
	GND	12.6 V	3 Cell $\times$ 4.20 V/Cell
	VREF	16.8 V	4 Cell $\times$ 4.20 V/Cell
GND pin (ADJ3 $\leq$ 0.2 V)	OPEN	8.2 V	2 Cell $\times$ 4.10 V/Cell
	GND	12.3 V	3 Cell $\times$ 4.10 V/Cell
	VREF	16.4 V	4 Cell $\times$ 4.10 V/Cell
External voltage setting (ADJ3 = 0.4 V to 4.4 V)	OPEN	4 $\times$ ADJ3 pin voltage	2 Cell $\times$ 2 $\times$ ADJ3 pin voltage/Cell
	GND	6 $\times$ ADJ3 pin voltage	3 Cell $\times$ 2 $\times$ ADJ3 pin voltage/Cell
	VREF	8 $\times$ ADJ3 pin voltage	4 Cell $\times$ 2 $\times$ ADJ3 pin voltage/Cell

• ADJ3 Pin Internal Circuit

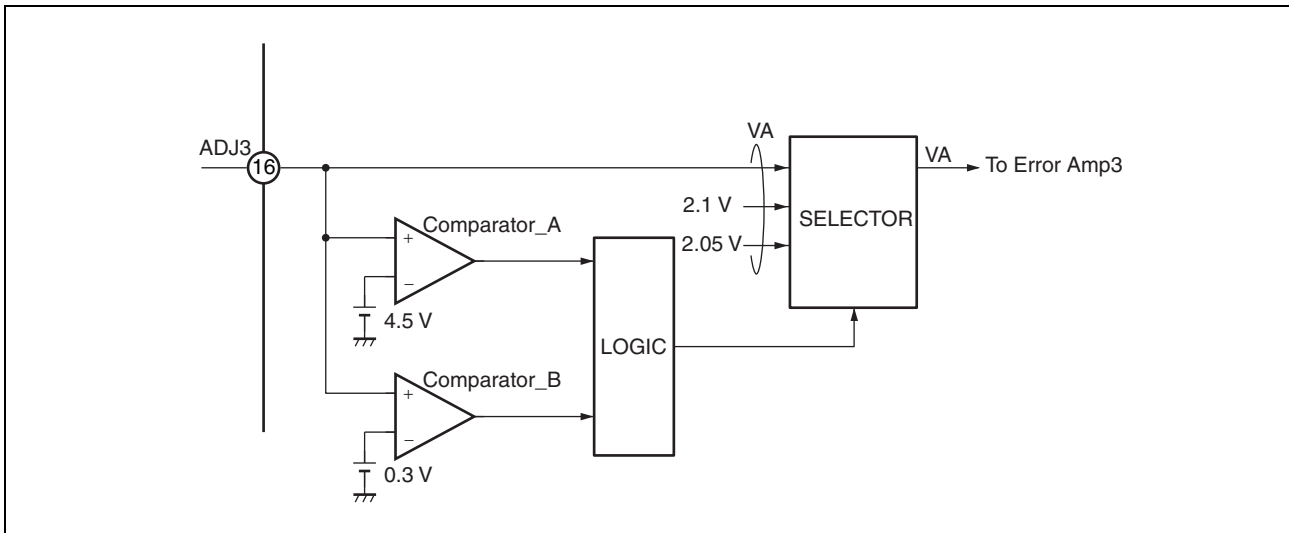

### 8.2.5 Setting the Charge Current

The Error amplifier block (Error Amp2) compares the output voltage of charge current control block set by ADJ2 pin (pin 9) with the output signal from the current detection amplifier (current Amp2), and outputs a PWM control signal to be used in controlling the maximum charge current for battery. When the current overflows the rated value, the current will be constantly charged to the rated value, and the charge voltage will drop.

Battery charge current setting voltage : ADJ2

$$\text{Upper limit of charge current } I_o = \frac{\text{Charge current control block output voltage (V)} - 0.075}{\text{Current detection amplifier block voltage gain (25.0 V/V Typ)} \times \text{sense resistor } R_S (\Omega)}$$

ADJ2 Input Voltage	Charge Current Control Block Output Voltage	Charge Current		
		$R_S = 40 \text{ m}\Omega$	$R_S = 20 \text{ m}\Omega$	$R_S = 15 \text{ m}\Omega$
VREF (ADJ2 > 4.6 V)	1.5 V	1.425 A	2.85 A	3.79 A
External Voltage Setting (ADJ2 = GND to 4.4 V)	$V_{ADJ2}$ (V)	$V_{ADJ2} - 0.075$ (A)	$2 \times (V_{ADJ2} - 0.075)$ (A)	$2.66 \times (V_{ADJ2} - 0.075)$ (A)

• ADJ2 Pin Internal Circuit

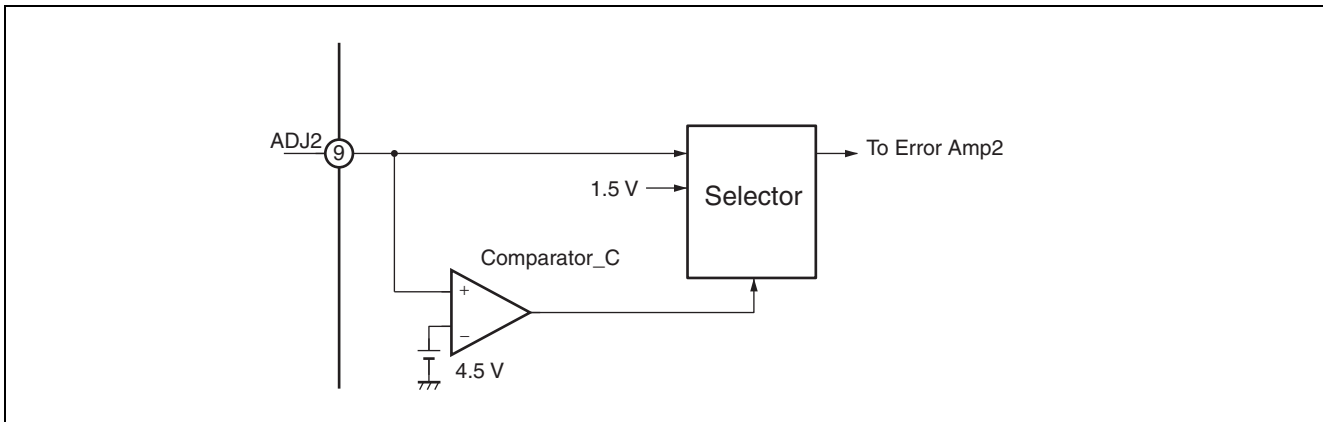

- Example of charge current setting ( $R_S = 40 \text{ m}\Omega$ )

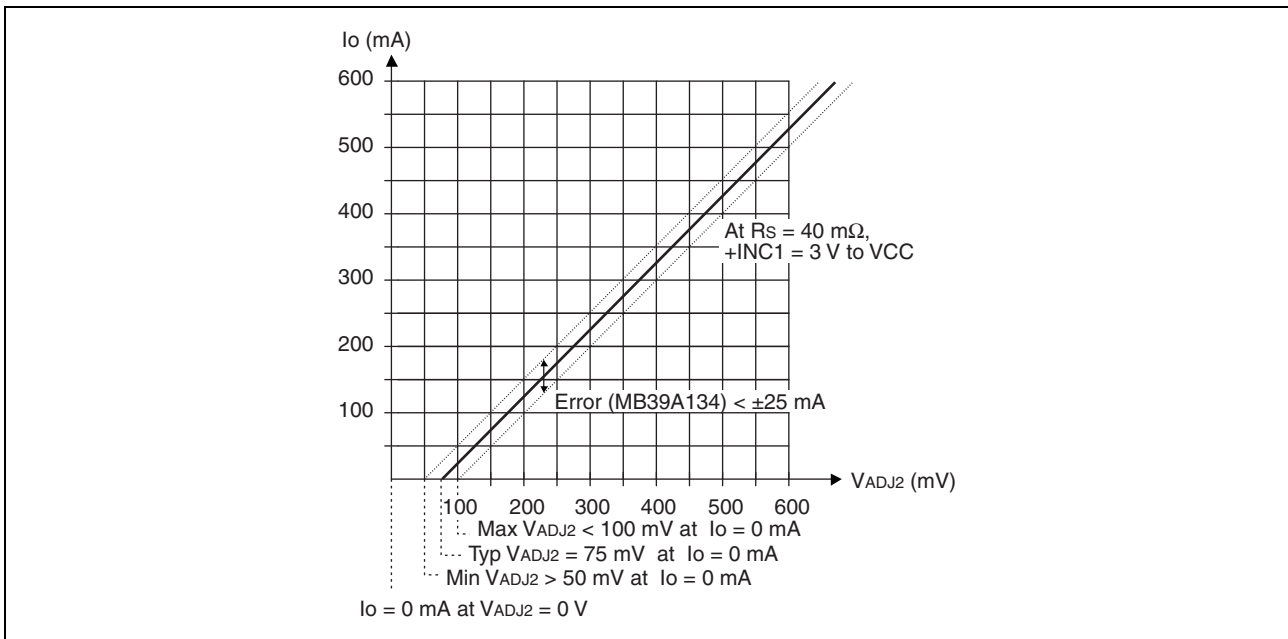
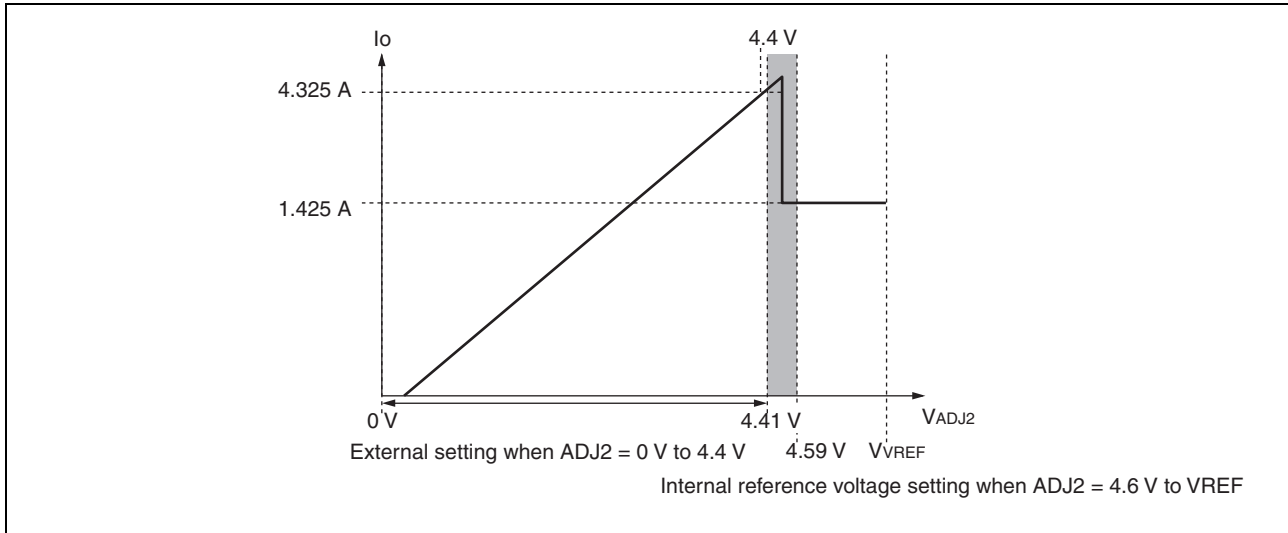

### 8.2.6 Setting Dynamically-Controlled-Charging

By connecting as shown in the example of the figure below, the AC adopter voltage ( $V_{IN}$ ) drops and becomes the calculated  $V_{th}$ , and then, the dynamically-controlled charging loop reduce the charge current to keep a settled power level.

AC adopter voltage in dynamically controlled charging mode:

$$V_{th} = V_{REF} \times \left( 1 - \frac{1}{A_V} \times \frac{R_4}{R_3 + R_4} \right) \times \frac{R_1 + R_2}{R_2}$$

$V_{REF}$  : Reference voltage (5.0 V Typ)     $A_V$  : Current detection amplifier block voltage gain (25.0 V/V Typ)

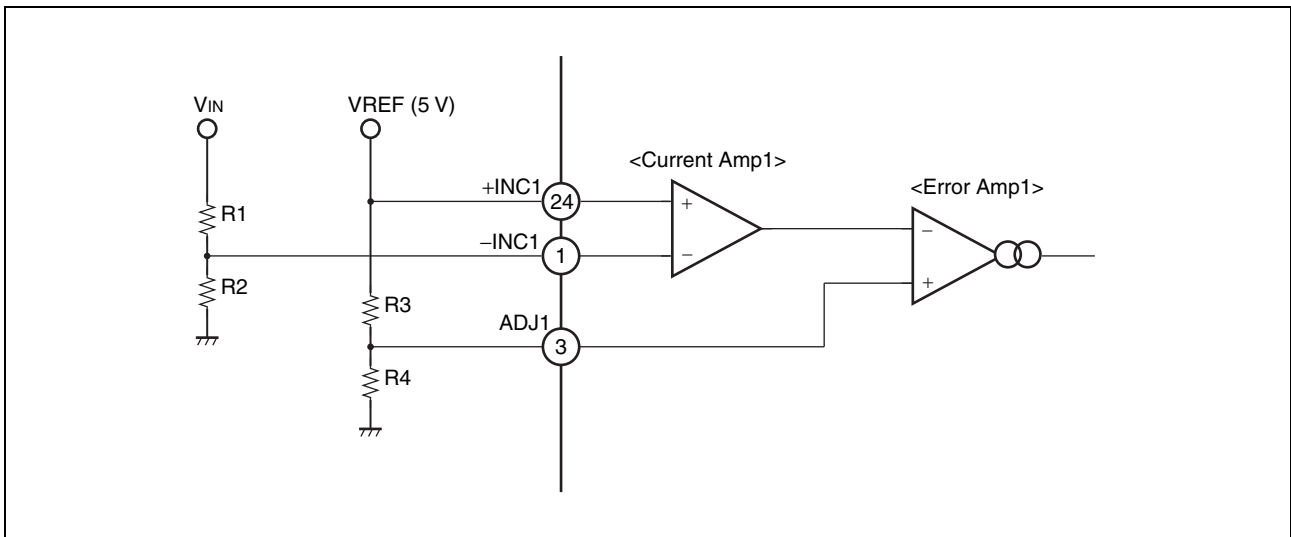

## 9. Transit Response When a Load Changes Suddenly

The constant voltage control loop and the constant current control loop are independent each other and when a load changes suddenly, these two control loops switch over each other.

Overshoot of the battery voltage and current is generated by the delay in the control loop when changing the mode.

The delay time is determined by the phase compensation components values.

When the constant current control switches over to the constant voltage control when removing the battery, the control period with higher duty than the rated charge voltage occurs, resulting in voltage overshoot. In such a period, since the battery is removed, no excessive voltage should be applied to the battery.

When the constant voltage control switches over to the constant current control when installing the battery, the control period with higher duty than the rated charge current occurs, resulting in current overshoot.

For MB39A134, it can not be as current overshoot with 10 ms or less.

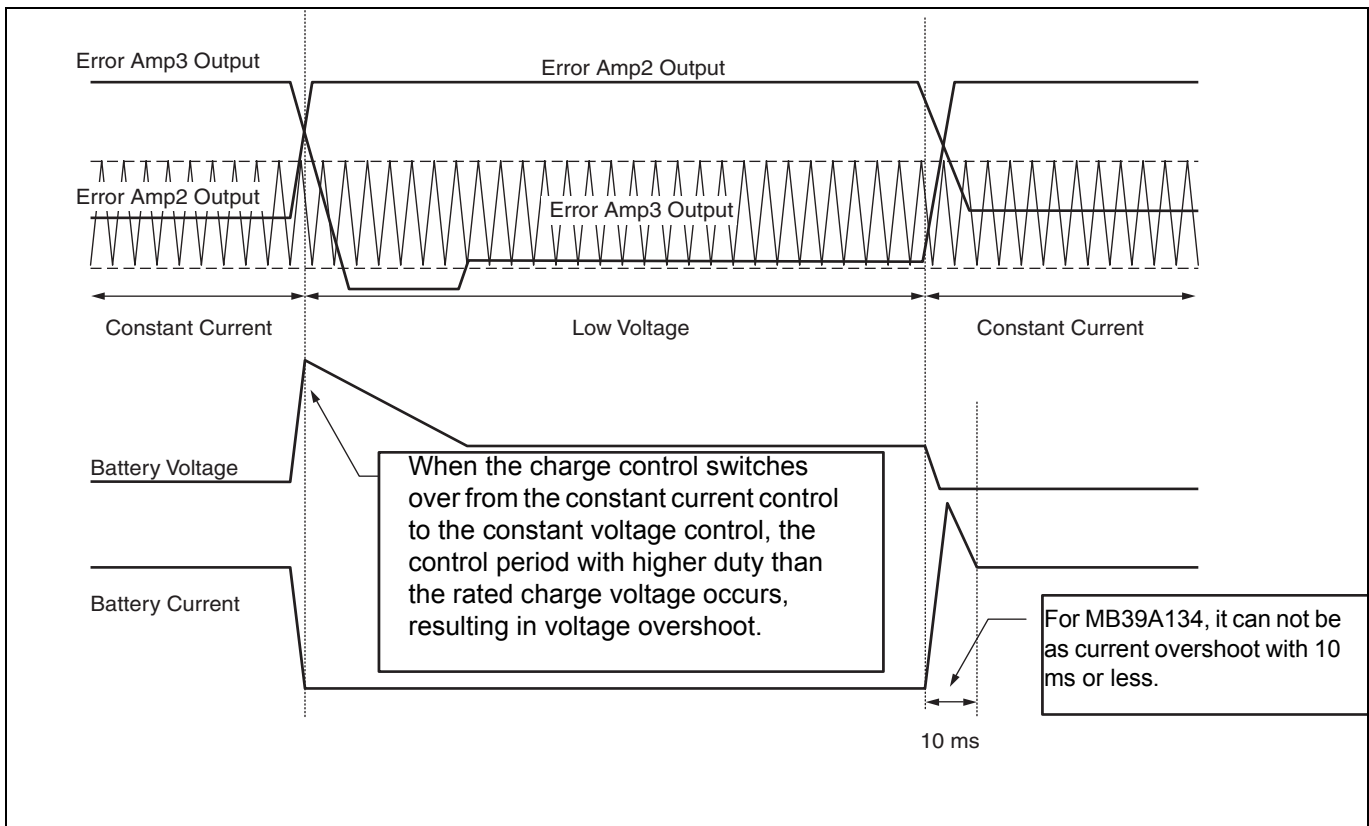

## 10. Connection Without Using The Current Amp1, Current Amp2 and The Error Amp1, Error Amp2

When Current Amp1, 2 or Error Amp1, 2 are not used, please connect it as follows.

- +INC1 pin (pin 24), -INC1 pin (pin 1), ADJ1 pin (pin 3), and ADJ2 pin (pin 9) are connected with the VREF pin.
- +INC2 pin (pin 13) is connected with the pin BATT pin (pin 12).
- OUTC1 pin (pin 2) and OUTC2 pin (pin 10) open.

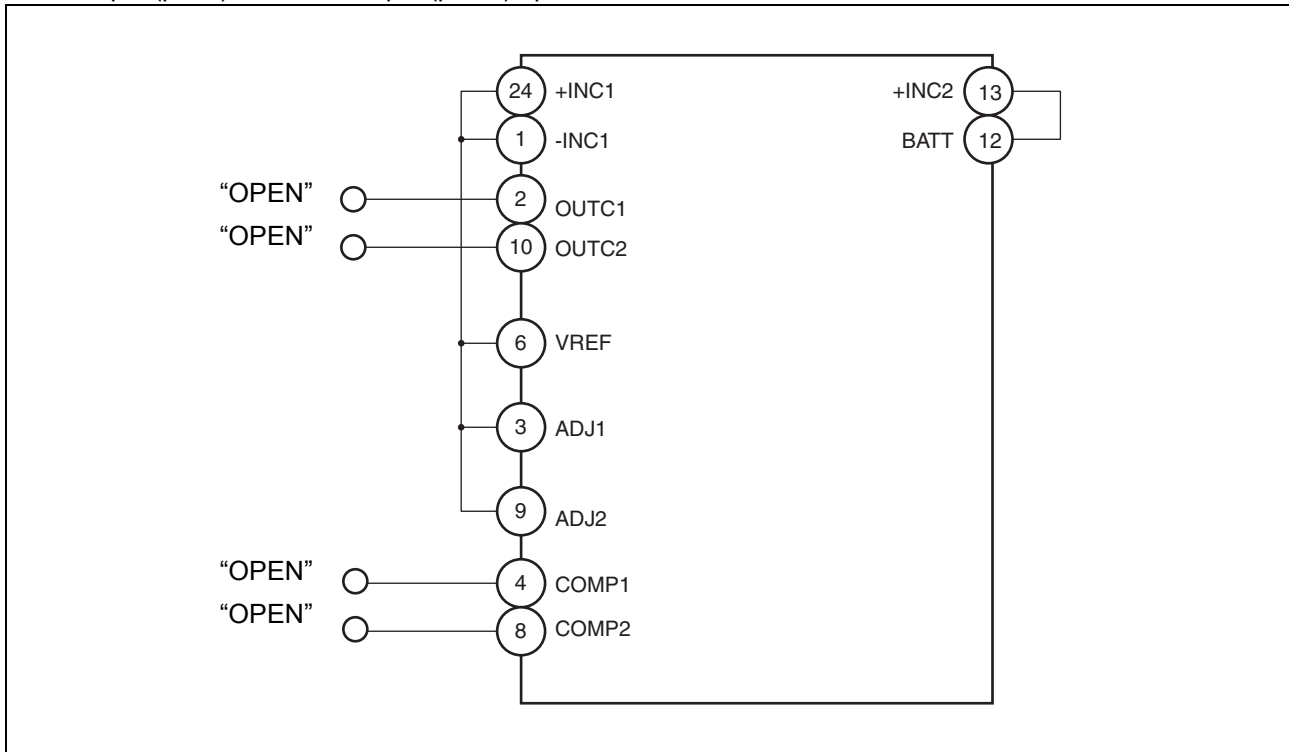

## 11. Input/Output Pin Equivalent Circuit Diagram

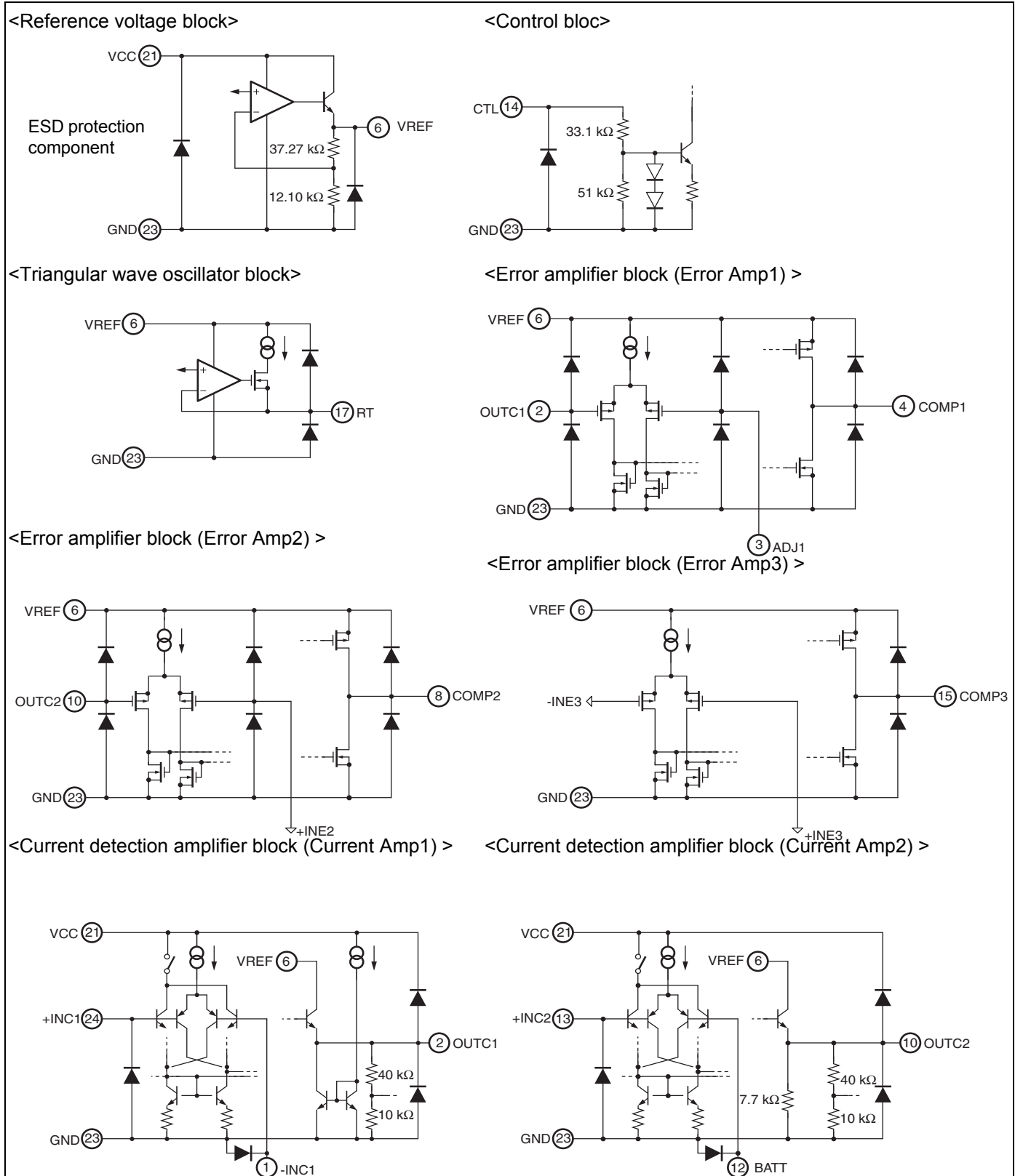

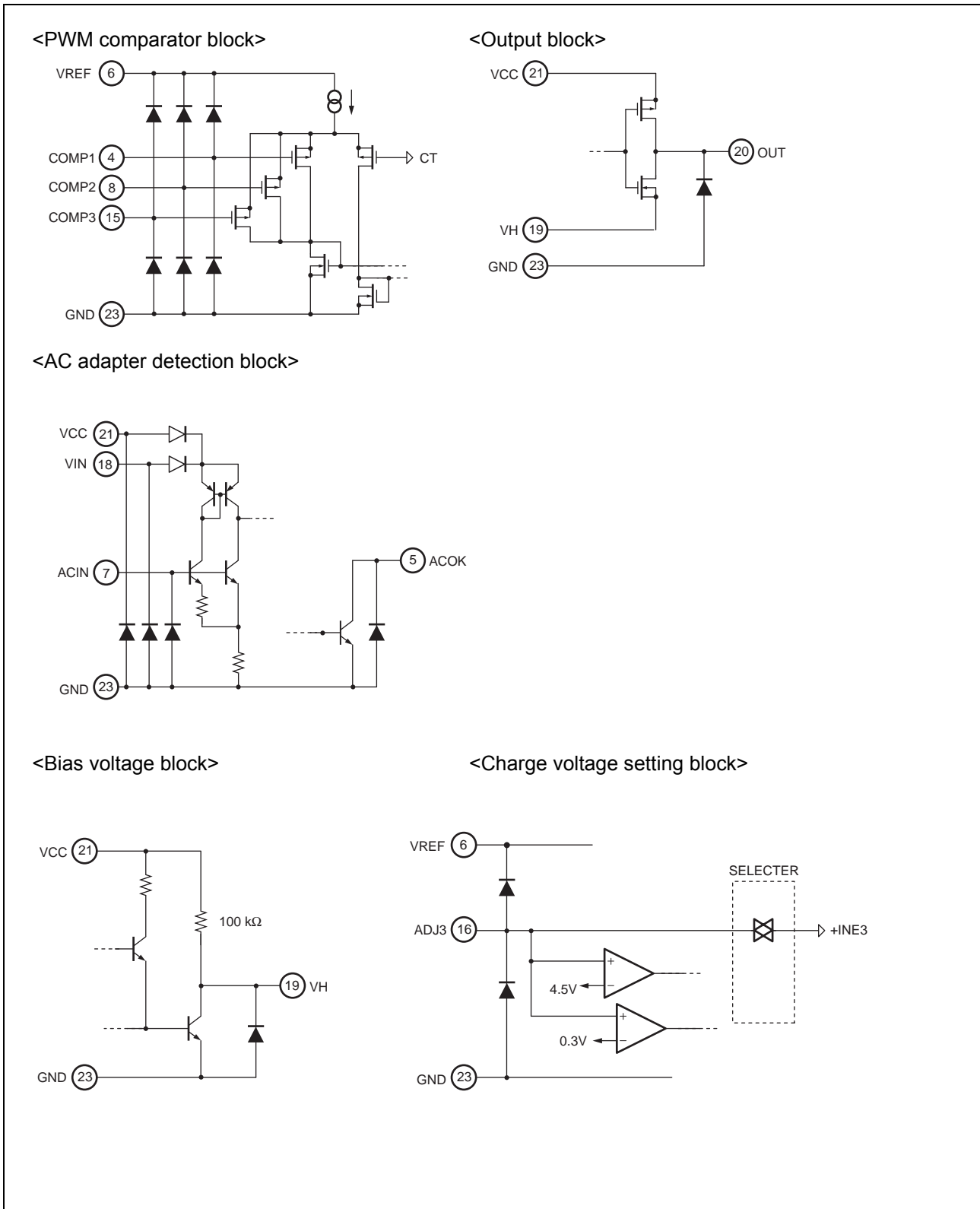

<Charge current setting block>

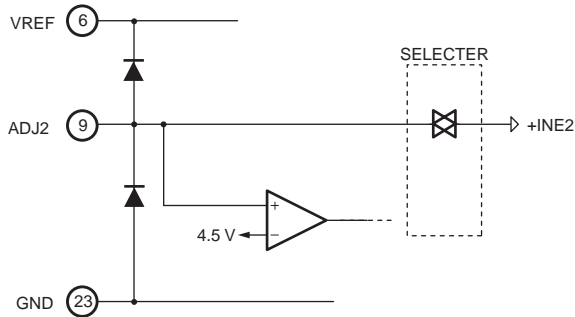

<Cell switch block>

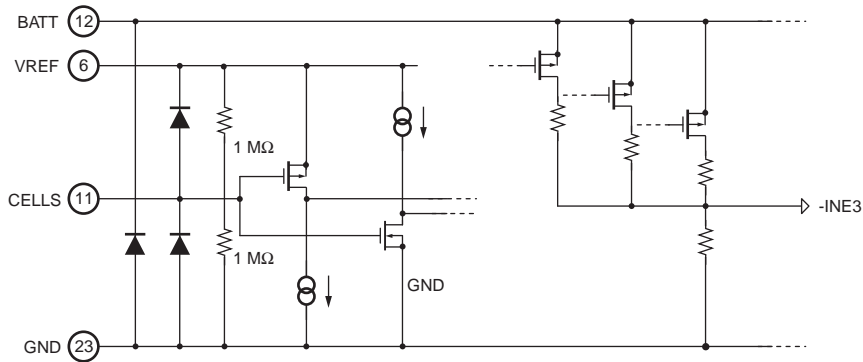

## 12. Typical Application Circuit

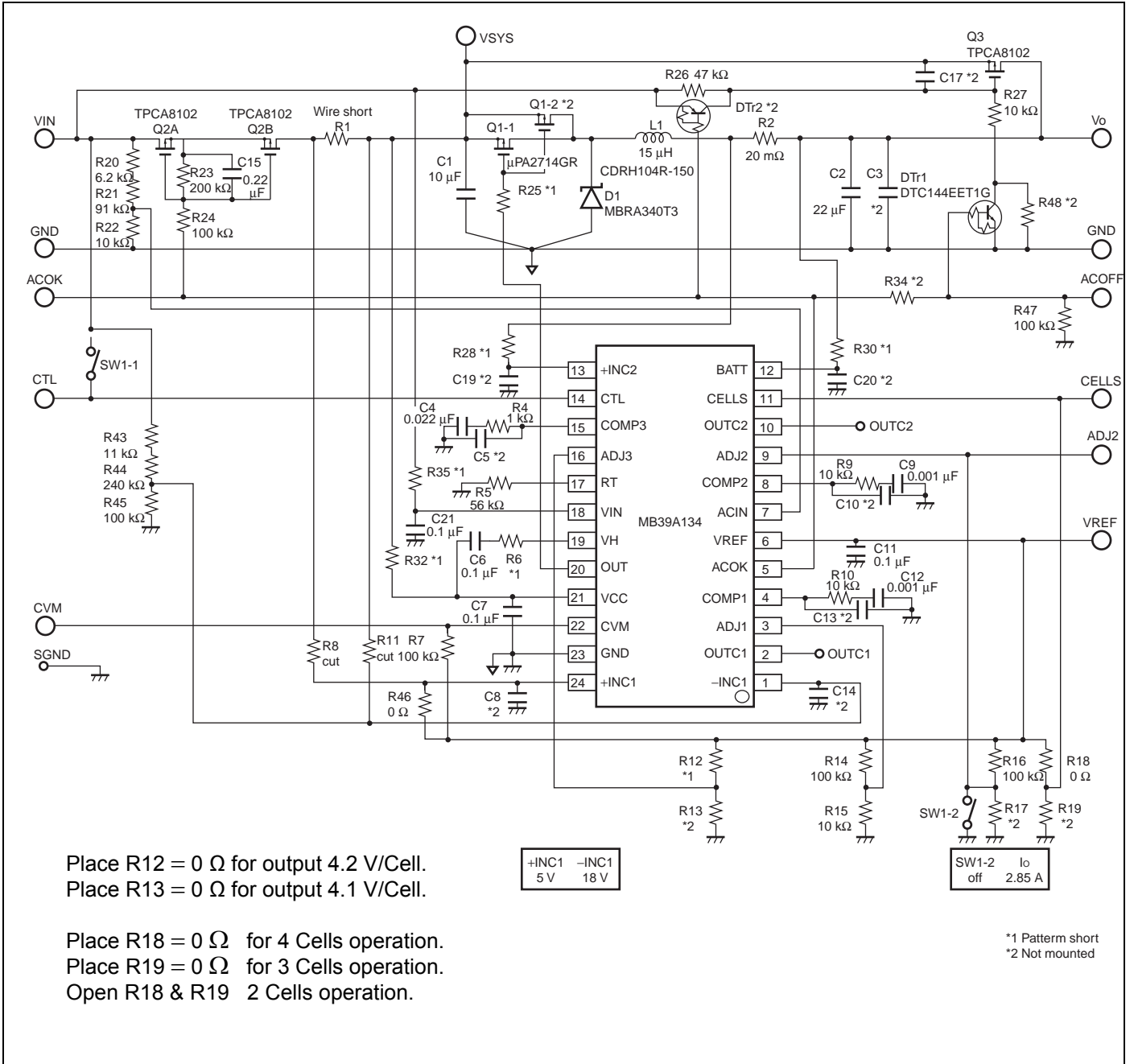

**• Parts List**

Component	Item	Specification	Vendor	Package	Parts No.	Remarks
M1	IC	MB39A134	Cypress	TSSOP-24	—	
Q1-1	P-ch FET	VDS = - 20 V, ID = 7 A (Max)	RENESAS	SOP-8	μPA2714GR	
Q1-2	P-ch FET	—	—	—	—	Not mounted
Q2A	P-ch FET	VDS = - 30 V, ID = 40 A (Max)	TOSHIBA	SOP Advance	TPCA8102	
Q2B	P-ch FET	VDS = - 30 V, ID = 40 A (Max)	TOSHIBA	SOP Advance	TPCA8102	
Q3	P-ch FET	VDS = - 30 V, ID = 40 A (Max)	TOSHIBA	SOP Advance	TPCA8102	
DTr1	Transistor	VCEO = 50 V	ON Semi	SC-75	DTC144EET1G	
DTr2	Transistor	—	—	—	—	Not mounted
D1	Diode	VF = 0.45 V (Max) at IF = 3 A	ON Semi	RMDS	MBRA340T3	
L1	Inductor	15 μH 50 mW Irms = 3.1 A	SUMIDA	SMD	CDRH104R-150	
C1	Ceramic Capacitor	10 μF (25 V)	TDK	3225	C3225X5R1E106K	
C2	Ceramic Capacitor	22 μF (25 V)	TDK	3225	C3225JC1E226M	
C3	Ceramic Capacitor	—	—	—	—	Not mounted
C4	Ceramic Capacitor	0.022 μF (50 V)	TDK	1608	C1608JB1H223K	
C5	Ceramic Capacitor	—	—	—	—	Not mounted
C6	Ceramic Capacitor	0.1 μF (50 V)	TDK	1608	C1608JB1H104K	
C7	Ceramic Capacitor	0.1 μF (50 V)	TDK	1608	C1608JB1H104K	
C8	Ceramic Capacitor	—	—	—	—	Not mounted
C9	Ceramic Capacitor	0.001 μF (50 V)	TDK	1608	C1608JB1H102J	
C10	Ceramic Capacitor	—	—	—	—	Not mounted
C11	Ceramic Capacitor	0.1 μF (50 V)	TDK	1608	C1608JB1H104K	
C12	Ceramic Capacitor	0.001 μF (50 V)	TDK	1608	C1608JB1H102J	
C13	Ceramic Capacitor	—	—	—	—	Not mounted
C14	Ceramic Capacitor	—	—	—	—	Not mounted
C15	Ceramic Capacitor	0.22 μF (25 V)	TDK	1608	C1608JB1H224K	
C17	—	—	—	—	—	Not mounted
C19	Ceramic Capacitor	—	—	—	—	Not mounted
C20	Ceramic Capacitor	—	—	—	—	Not mounted
C21	Ceramic Capacitor	0.1 μF (50 V)	TDK	1608	C1608JB1H104K	

Component	Item	Specification	Vendor	Package	Parts No.	Remarks
R1	Resistor	0 Ω	Mac-Eight	SMD	MJP-0.2	Wire short
R2	Resistor	20 mΩ	KOA	SL1	SL1TTE20L0D	
R4	Resistor	1 kΩ	SSM	1608	RR0816P102D	
R5	Resistor	56 kΩ	SSM	1608	RR0816P563D	
R6	Resistor	—	—	—	—	Pattern short
R7	Resistor	100 kΩ	SSM	1608	RR0816P104D	
R8	Resistor	∩	—	—	—	Pattern cut
R9	Resistor	10 kΩ	SSM	1608	RR0816P103D	
R10	Resistor	10 kΩ	SSM	1608	RR0816P103D	
R11	Resistor	—	—	—	—	Pattern cut
R12	Resistor	—	—	—	—	Pattern short
R13	Resistor	—	—	—	—	Not mounted
R14	Resistor	100 kΩ	SSM	1608	RR0816P104D	
R15	Resistor	10 kΩ	SSM	1608	RR0816P103D	
R16	Resistor	100 kΩ	SSM	1608	RR0816P104D	
R17	Resistor	—	—	—	—	Not mounted
R18	Resistor	0 Ω	KOA	1608	RK73Z1J	
R19	Resistor	—	—	—	—	Not mounted
R20	Resistor	6.2 kΩ	SSM	1608	RR0816P622D	
R21	Resistor	91 kΩ	SSM	1608	RR0816P913D	
R22	Resistor	10 kΩ	SSM	1608	RR0816P103D	
R23	Resistor	200 kΩ	SSM	1608	RR0816P204D	
R24	Resistor	100 kΩ	SSM	1608	RR0816P104D	
R25	Resistor	—	—	—	—	Pattern short
R26	Resistor	47 kΩ	SSM	1608	RR0816P473D	
R27	Resistor	10 kΩ	SSM	1608	RR0816P103D	
R28	Resistor	—	—	—	—	Pattern short
R30	Resistor	—	—	—	—	Pattern short
R32	Resistor	—	—	—	—	Pattern short
R34	—	—	—	—	—	Not mounted
R35	Resistor	—	—	—	—	Pattern short
R43	Resistor	11 kΩ	SSM	1608	RR0816P113D	
R44	Resistor	240 kΩ	SSM	1608	RR0816P244D	
R45	Resistor	100 kΩ	SSM	1608	RR0816P104D	
R46	Resistor	0 Ω	KOA	1608	RK73Z1J	

Component	Item	Specification	Vendor	Package	Parts No.	Remarks
R47	Resistor	100 kΩ	SSM	1608	RR0816P104D	
R48	—	—	—	—	—	Not mounted
SW1	DIP SW	SW	MATSUKYU	SMD	DMS-2H	
PIN	Wiring Pin	WT-2-1	Mac-Eight	—	WT-2-1	11-pin

Note : These components are recommended based on the operating tests authorized.

RENESAS : Renesas Electronics Corporation

TOSHIBA : TOSHIBA Corporation

ON Semi : ON Semiconductor

SUMIDA : SUMIDA Corporation

TDK : TDK Corporation

Mac-Eight : Mac-Eight Co.,Ltd

KOA : KOA Corporation

SSM : SUSUMU Co.,Ltd

MATSUKYU : Matsuky Co.,Ltd

### 13. Application Note

- Inductor selection

The inductance value should be selected, as a reference, so that the peak-to-peak value of the inductor ripple current is 50% or less of the maximum charge current. In such a case, the inductance value can be obtained as follows :

$$L \geq \frac{V_{IN} - V_O}{LOR \times I_{OMAX}} \times \frac{V_O}{V_{IN} \times f_{OSC}}$$

L	: Inductance value [H]
I <sub>OMAX</sub>	: Max. charge current [A]
LOR	: Peak-to-peak value of inductor ripple current - max. charge current ratio (0.5)
V <sub>IN</sub>	: Switching system power supply voltage [V]
V <sub>O</sub>	: Charge voltage [V]
fosc	: Switching frequency [Hz]

The minimum charge current value (critical current value) without backward inductor current can be obtained as follow :

$$I_{OC} = \frac{V_O}{2 \times L} \times \frac{V_{IN} - V_O}{V_{IN} \times f_{OSC}}$$

I <sub>OC</sub>	: Critical current [A]
L	: Inductance value [H]
V <sub>IN</sub>	: Switching system power supply voltage [V]
V <sub>O</sub>	: Charge voltage [V]
fosc	: Switching frequency [Hz]

To judge that the current passing through the inductor is below a rated value, it is necessary to obtain a maximum current value passing through the inductor. The maximum inductor current value can be obtained as follows :

$$I_{LMAX} \geq I_{OMAX} + \frac{\Delta IL}{2}$$

I <sub>LMAX</sub>	: Max. inductor current [A]
I <sub>OMAX</sub>	: Max. charge current [A]
ΔIL	: Peak-to-peak value of inductor ripple current [A]

$$\Delta IL \geq \frac{V_{IN} - V_O}{L} \times \frac{V_O}{V_{IN} \times f_{OSC}}$$

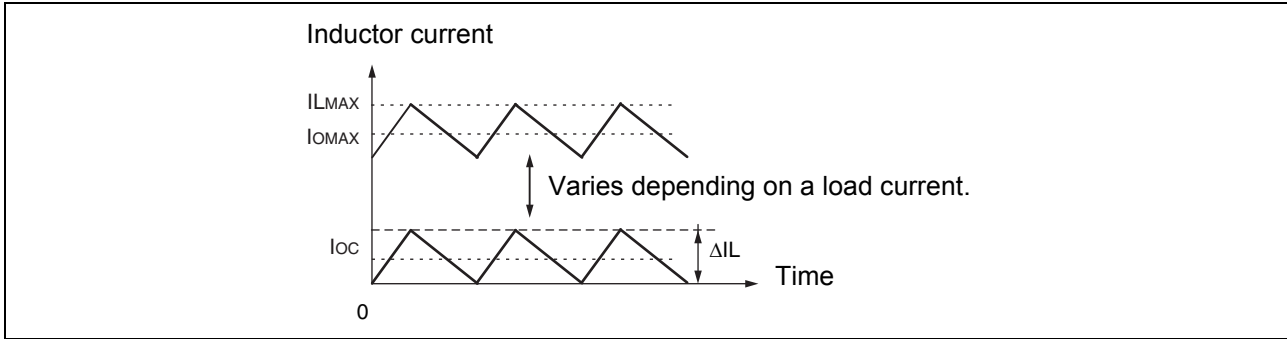

• Switching FET Selection

If MB39A134 is used for the charger for a notebook PC, since the output voltage of an AC adapter, which is the input voltage of an switching FET, is 25 V or less, in general, a 30 V class MOS FET can be used as the switching FET. Obtain the maximum value of the current flowing through the switching FET in order to determine whether the current flowing through the switching FET is within the rated value. The maximum current flowing through the switching FET can be found by the following formula.

$$I_{D\text{MAX}} \geq I_{O\text{MAX}} + \frac{\Delta I_L}{2}$$

- $I_{D\text{MAX}}$  : Max. switching FET drain current [A]
- $I_{O\text{MAX}}$  : Max. charge current [A]
- $\Delta I_L$  : Peak-to-peak value of inductor ripple current [A]

In addition, to judge that permissible switching FET loss is below the rated value, it is necessary to obtain the switching FET loss. To reduce switching FET loss as much as possible. when selecting a switching FET, take into consideration that the continuity loss is equal to the switching loss.

The switching FET continuity loss can be obtained by the following formula:

$$P_{R\text{on}} = \frac{V_O}{V_{\text{IN}}} \times I_O^2 \times R_{\text{on}}$$

- $P_{R\text{on}}$  : Switching FET continuity loss [W]
- $I_O$  : Charge current [A]
- $V_{\text{IN}}$  : Switching system power supply voltage [V]
- $V_O$  : Charge voltage [V]
- $R_{\text{on}}$  : Switching FET on resistance [ $\Omega$ ]

The switching FET switching loss can be obtained simply as follows :

$$P_{SW} = \frac{1}{2} \times V_{IN} \times I_{L_{MIN}} \times f_{osc} \times T_r + \frac{1}{2} \times V_{IN} \times I_{L_{MAX}} \times f_{osc} \times T_f$$

$P_{SW}$	: Switching FET switching loss [W]
$I_{L_{MIN}} = I_{O_{MAX}} - \Delta I_L / 2$	: Lower value of inductor current [A]
$I_{L_{MAX}} = I_{O_{MAX}} + \Delta I_L / 2$	: Upper value of inductor current [A]
$V_{IN}$	: Switching system power supply voltage [V]
$f_{osc}$	: Switching frequency [Hz]
$T_r$	: Switching FET turn-on time [s]
$T_f$	: Switching FET turn-off time [s]

• Flyback Diode Selection

Select the shot-key barrier diode (Flyback diode) with a small forward voltage as much as possible.

To judge that the current passing through the flyback diode is below the rated value, it is necessary to obtain the value of peak current passing through the flyback diode. The maximum current value of the flyback diode can be obtained as follows :

$$I_f \geq I_{O_{MAX}} + \frac{\Delta I_L}{2}$$

$I_f$	: Forward current [A]
$I_{O_{MAX}}$	: Max. charge current [A]
$\Delta I_L$	: Peak-to-peak value of inductor ripple current [A]

Furthermore, to judge that permissible flyback diode loss is below a rated value, it is necessary to obtain the flyback diode loss. The flyback diode loss can be obtained as follows :

$$P_{SBD} = I_{O_{MAX}} \times \left(1 - \frac{V_O}{V_{IN}}\right) \times V_f$$

$P_{SBD}$	: Flyback diode loss [W]
$I_{O_{MAX}}$	: Max. charge current [A]
$V_{IN}$	: Switching system power supply voltage [V]
$V_O$	: Charge voltage [V]
$V_f$	: Forward voltage [V]

- Output Capacitor Selection

Since a high ESR causes the output ripple voltage to increase, a low-ESR capacitor is needed to be used in order to reduce the output ripple voltage. Use a capacitor that has sufficient ratings to surge current generated when the battery is inserted or removed. Generally, the ceramic capacitor is used as the output capacitor.

With the switching ripple voltage taken into consideration, the minimum capacitance required can be found by the following formula.

$$C_o \geq \frac{1}{2\pi \times f_{osc} \times \left( \frac{\Delta V_O}{\Delta I_L} - ESR \right)}$$

- $C_o$  : Output capacitor [F]
- ESR : Serial resistance of output capacitor [ $\Omega$ ]
- $\Delta V_O$  : Switching ripple voltage [V]
- $\Delta I_L$  : Peak-to-peak value of inductor ripple current [A]
- $f_{osc}$  : Switching frequency [Hz]

Since an overshoot occurs in the DC/DC converter output voltage when a battery being charged is removed, use a capacitor having sufficient withstand voltage. Generally, the capacitor having a rated withstand voltage higher than the maximum input voltage is used.

Moreover, use a capacitor having sufficient tolerance for allowable ripple current. The allowable ripple current required can be found by the following formula.

$$I_{rms} \geq \frac{\Delta I_L}{2\sqrt{3}}$$

- $I_{rms}$  : Acceptable ripple current (effective value) [A]
- $\Delta I_L$  : Peak-to-peak value of inductor ripple current [A]

• Input Capacitor Selection

Select an input capacitor that has an ESR as small as possible. A ceramic capacitor is ideal. If a high capacitance capacitor is needed for which there is no suitable ceramic capacitor use a polymer capacitor or a tantalum capacitor having a low ESR. The ripple voltage by the switching operation of the DC/DC converter is generated in the power supply voltage. Please consider the lower limit value of the input capacitor according to the allowable ripple voltage. The ripple voltage of the power supply can be easily found by the following formula.

$$\Delta V_{IN} = \frac{I_{OMAX}}{C_{IN}} \times \frac{V_O}{V_{IN} \times f_{OSC}} + ESR \times \left( I_{OMAX} + \frac{\Delta IL}{2} \right)$$

$\Delta V_{IN}$	: Peak-to-peak value of switching system power supply ripple voltage [V]
$I_{OMAX}$	: Maximum charge current [A]
$C_{IN}$	: Input capacitor [F]
$V_{IN}$	: Switching system power supply voltage [V]
$V_O$	: Charge voltage [V]
$f_{OSC}$	: Switching frequency [Hz]
ESR	: Series resistance component of input capacitor [ $\Omega$ ]
$\Delta IL$	: Peak-to-peak value of inductor ripple current [A]

The ripple voltage of the power supply can be decreased by raising the switching frequency besides using the capacitor. The capacitor has the features in the frequency, temperature and bias voltage, so that the effect capacitance can be extremely small depending on the use conditions.

Please choose the one of having the enough margin for the input voltage and ripple current to ratings of the capacitor.

The acceptable ripple current is given by the following formula.

$$I_{rms} \geq I_{OMAX} \times \frac{\sqrt{V_O \times (V_{IN} - V_O)}}{V_{IN}}$$

$I_{rms}$	: Acceptable ripple current (effective value) [A]
$I_{OMAX}$	: Maximum charge current [A]
$V_{IN}$	: Switching system power supply voltage [V]
$V_O$	: Charge voltage [V]

- Designing Phase Compensation Circuit

**(1) Constant Voltage (CV) Mode Phase Compensation Circuit**

It is common to connect a 1-pole-1-zero phase compensation circuit to the output pin (COMP3) of the error amplifier 3 (gm amplifier). When a low-ESR capacitor, such as a ceramic capacitor, is used as the output capacitor, it is easier for the DC/DC converter to oscillate as the phase delay approaches 180 degrees due to the resonance frequency of LC. In this situation, perform phase compensation by connecting a RC phase lead compensator to the COMP3 pin, and between the -INE3 pin and the BATT pin.

**Figure 1. 1pole-1zero Phase Compensation Circuit**

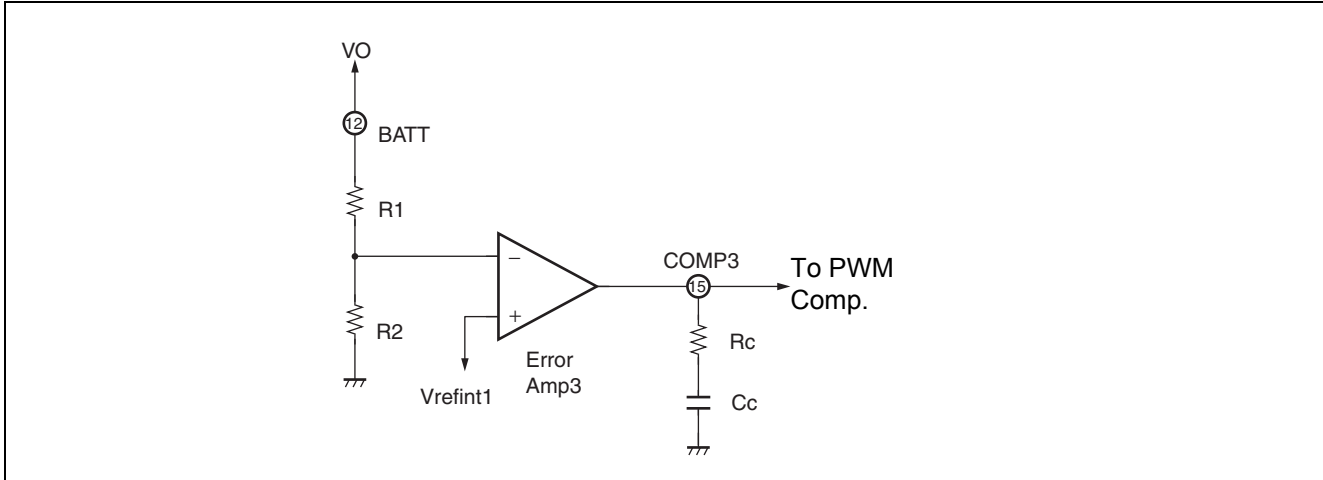

Rc (Ω) and Cc (F) of the phase lead circuit can be obtained by the following formula.

$$R_C \approx \frac{I_O}{190 \times 10^{-6} \times V_{IN}} \times \sqrt{\frac{L}{C_o}}$$

$$C_C \approx \frac{\sqrt{L \times C_o}}{R_C}$$

- IO : Charge current [A]
- VIN : Switching system power supply voltage [V]
- L : Inductance value of inductor [H]
- Co : Output capacitor value [F]
- VO : Charge voltage [V]

In this situation, the crossover frequency fco [Hz] can be obtained by the following formula.

$$f_{CO} \approx 1 \times 10^{-5} \times \frac{V_{IN}}{V_O \times C_C}$$

**(2) Constant Current (CC) Mode Phase Compensation Circuit**

Since the output capacitor impedance has a small influence to the loop response characteristics in this mode, the phase compensation circuit with 1pole-1zero is normally connected to the output pin (COMP2) of the error amplifier 2 (gm amplifier) .

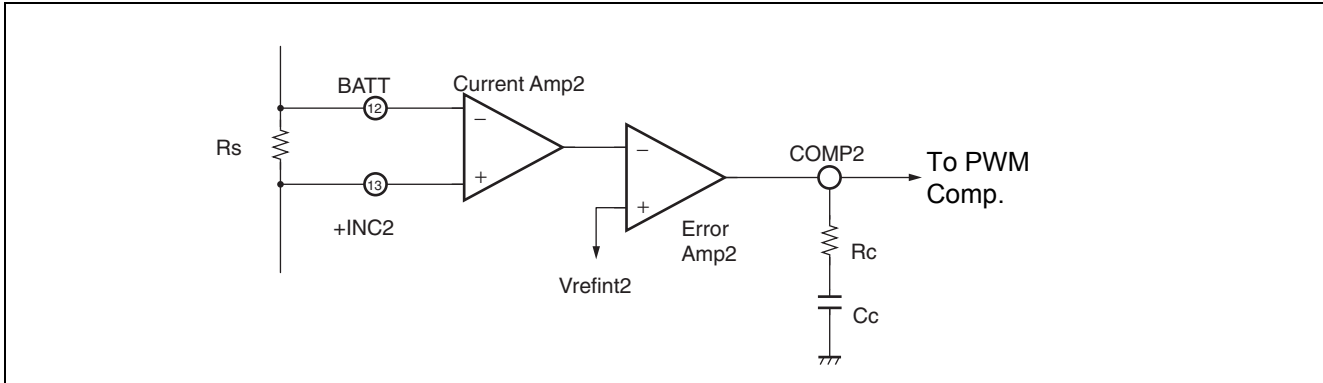
**Figure 2. 1pole-1zero Phase Compensation Circuit**

$R_C$  ( $\Omega$ ) and  $C_C$  (F) of the phase lead circuit can be obtained by the following formula.

$$R_C \approx 1.2 \times 10^4 \times \frac{f_{CO} \times L}{R_S \times V_{IN}}$$

$$C_C \approx \frac{\sqrt{L \times C_o}}{R_C}$$

$R_S$  : Resistance value of charge current detection [ $\Omega$ ]

$V_{IN}$  : Switching system power supply voltage [V]

$L$  : Inductance value [H]

$C_o$  : Output capacitance value [F]

$f_{CO}$  : Crossover frequency [Hz]

- Allowable Loss, and Thermal Design

In general, the allowable loss and thermal design of this IC can be ignored because this IC is highly effective. However, when this IC is used with high power supply voltage, high switching frequency, high load, or high temperature, it is necessary to take account of the allowable loss and thermal design while using this IC.

The IC internal loss ( $P_{IC}$ ) can be found by the following formula.

$$P_{IC} = V_{CC} \times (I_{CC} + Q_g \times f_{OSC})$$

$P_{IC}$  : IC's Internal loss [W]

$V_{CC}$  : Power supply voltage ( $V_{IN}$ ) [V]

$I_{CC}$  : Power supply current [A] (4.0 mA Max)

$Q_g$  : Total amount of charges of all switching FETs [C] (when  $V_{gs} = 6$  V)

$f_{OSC}$  : Switching frequency [Hz]

The temperature at the joint part ( $T_j$ ) can be obtained as follows :

$$T_j = T_a + \theta_{ja} \times P_{IC}$$

$T_j$  : Joint part temperature [°C]

$T_a$  : Ambient temperature [°C]

$\theta_{ja}$  : TSSOP-24 package thermal resistance (78°C / W)

$P_{IC}$  : IC's internal loss [W]

• Board Layout

When designing the layout, consider the points listed below. Take account of the following points when designing the board layout.

- Place a GND plane on the IC mounting surface whenever possible. Connect the controller GND to PGND only at one point of PGND in order to prevent a large current path from passing the controller GND.
- Connect to the input capacitor ( $C_{IN}$ ), switching FET, flyback diode, inductor (L), sense resistance ( $R_s$ ), and the output capacitor ( $C_o$ ) on the surface layer. Do not connect to them via any through-hole.
- For a loop composed of input capacitors ( $C_{IN}$ ), switching FET and flyback diode, minimize its current loop. When minimizing routing and loops, give priority to this loop over others.
- Connect GND pins of the input capacitor ( $C_{IN}$ ), flyback diode, and the output capacitor ( $C_o$ ) to GNDs on the inner layer via the through holes by making them close to the pins.
- Large currents momentarily flow through the nets of the OUT pin, which are connected to the switching FET gate. Use a wiring width of about 0.8 mm and minimize the length of routing.
- Place the bypass capacitor connected to VCC, VIN, VREF, and VH pins, and the resistance connected to the RT pin as close to the respective pins as possible. Moreover, connect the bypass capacitor and the GND pins of the VCC, VIN, and VREF of the  $f_{OSC}$ -setting resistance in close proximity to the GND pin of the IC. (Strengthen the connection to the internal layer GND by making through-holes in close proximity to each of the GND pin of the IC, terminals of bypass capacitors, terminals of the fosc setting resistors.)
- Since nets of -INC1, +INCx, BATT, COMPx, and RT pins are sensitive to noise, make wiring for them as shortly as possible, and keep them away from switching system parts as much as possible.
- The remote sensing (Kelvin connection) of the routing of the +INC2 and BATT pins are very sensitive to noise. Therefore, make their routing close to each other and keep the routing as far away from switching components as possible.

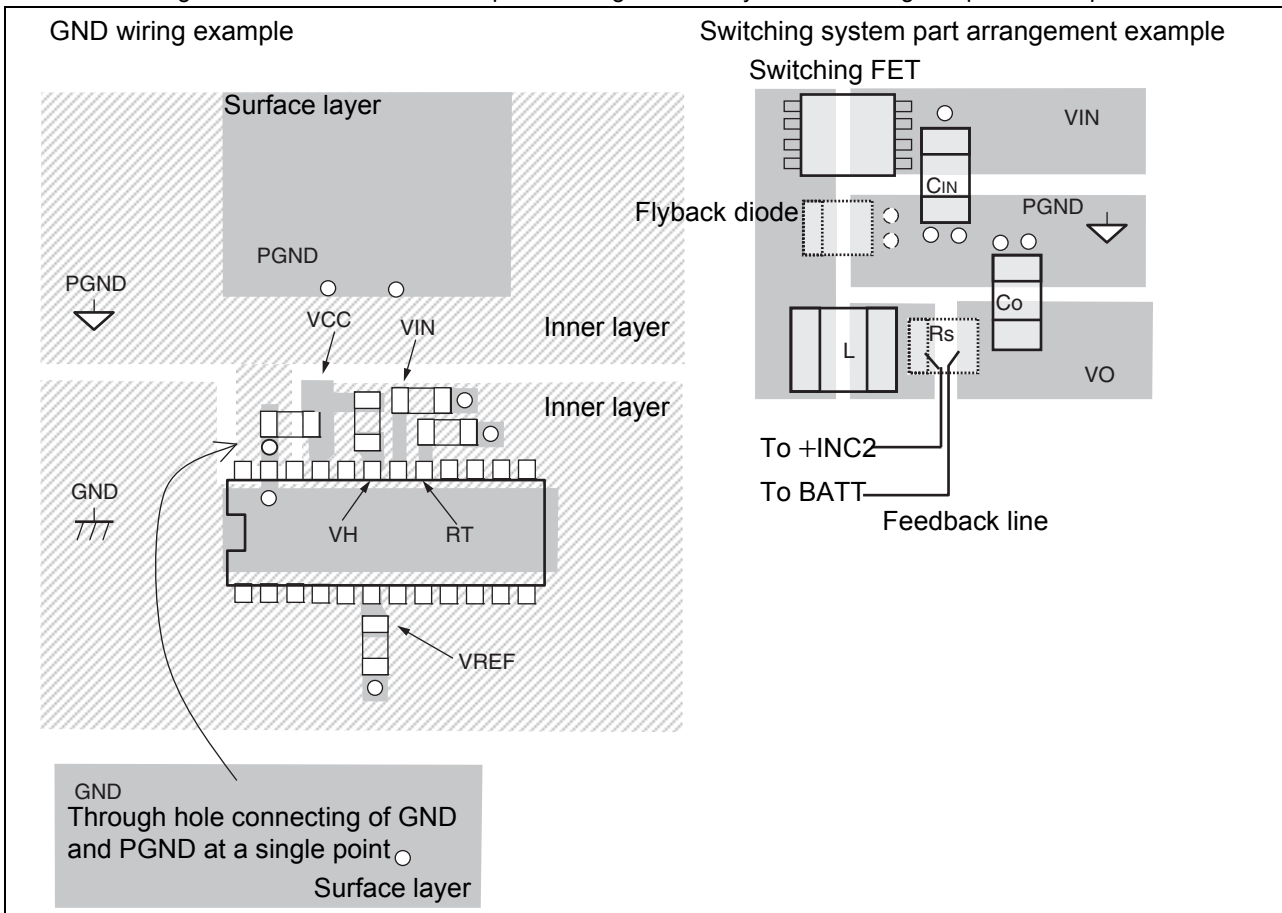

### 14. Reference Data

Unless explained specially, the measurement conditions are  $V_{IN} = 19\text{ V}$ ,  $I_O = 2.85\text{ A}$ , Li+ battery 4 Cell, and  $T_a = +25^\circ\text{C}$ .

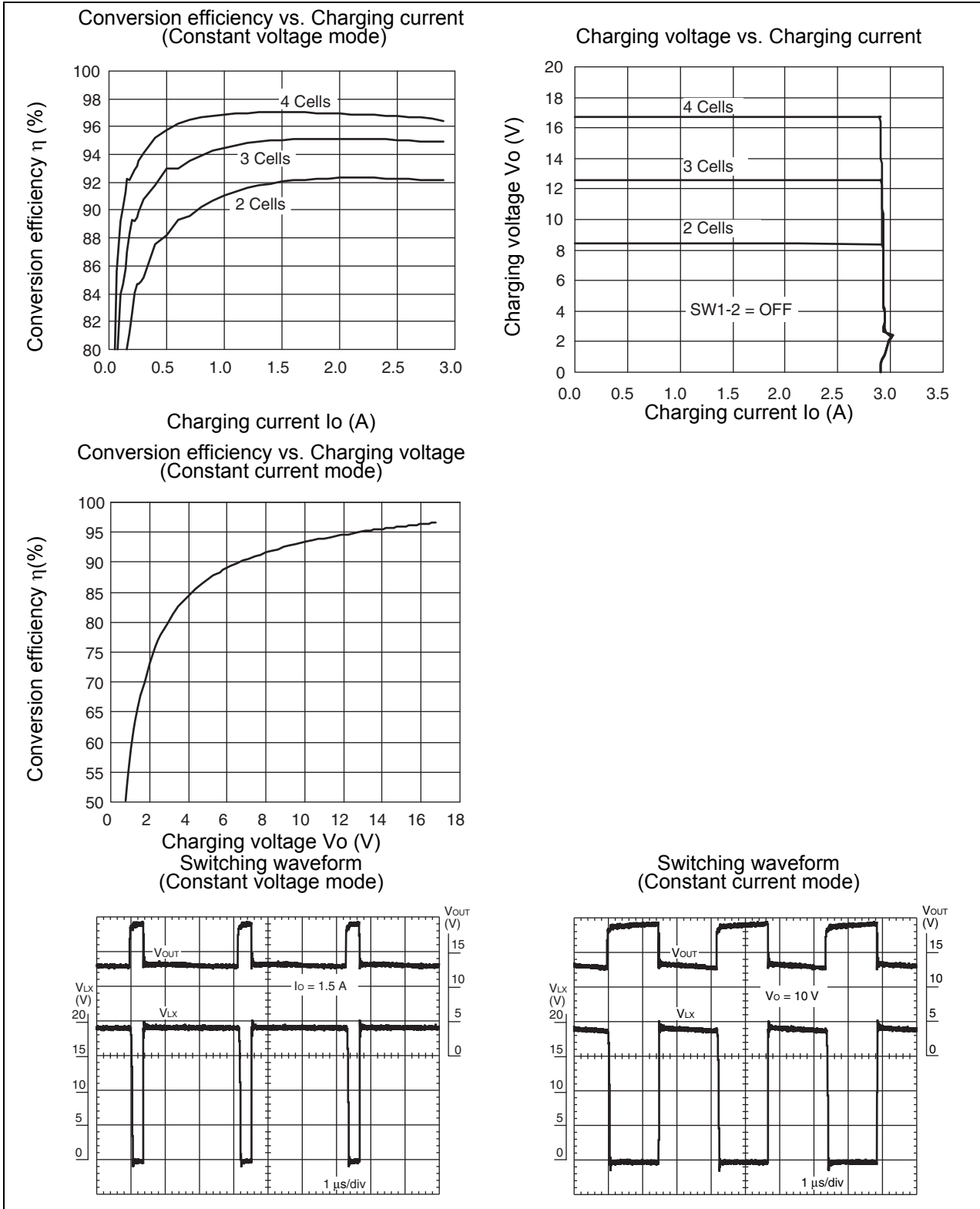

Start and stop  
(Constant voltage mode)

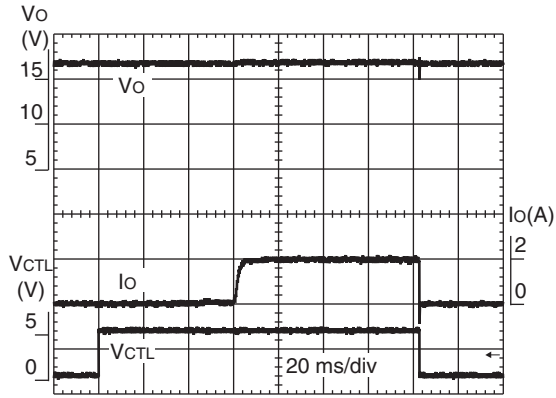

Start and stop  
(Constant current mode)

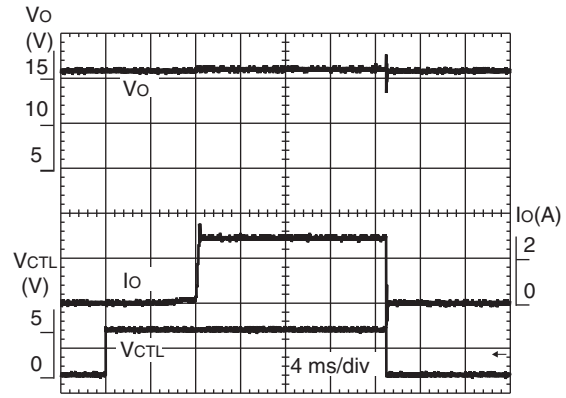

Load-step response  
(Constant voltage mode)  
Battery insertion

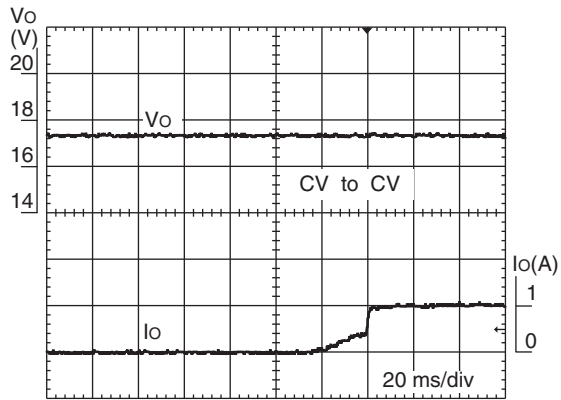

Load-step response  
(Constant voltage mode)  
Battery removal

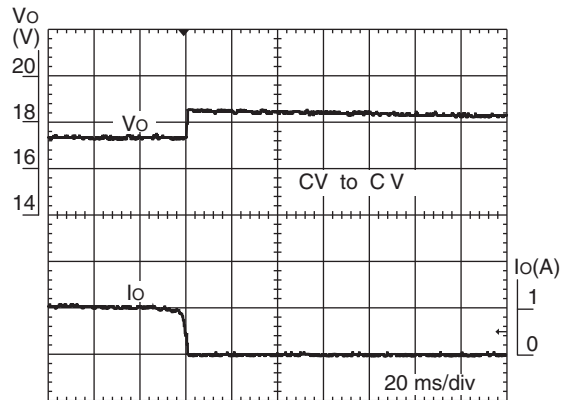

Load-step operation response  
(Constant current mode)  
Battery insertion

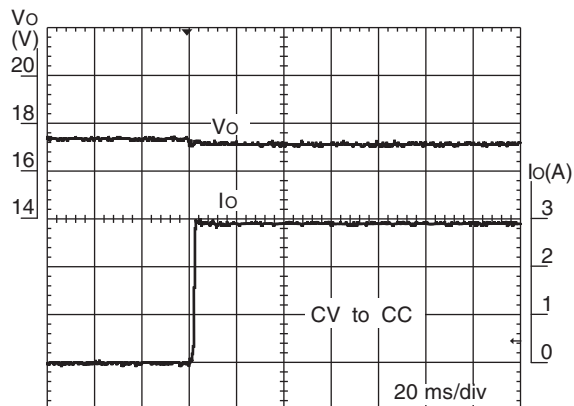

Load-step operation response  
(Constant current mode)  
Battery removal

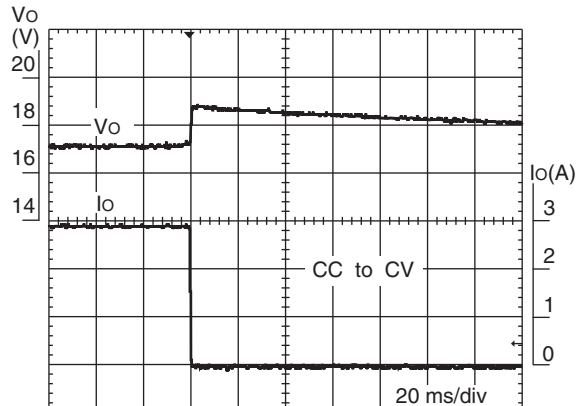

## 15. Usage Precaution

### 1. Do not Configure the IC Over the Maximum Ratings

If the IC is used over the maximum ratings, the LSI may be permanently damaged.

It is preferable for the device to be normally operated within the recommended usage conditions. Usage outside of these conditions can have a bad effect on the reliability of the LSI.

### 2. Use the Devices within Recommended Operating Conditions

The recommended operating conditions are the recommended values that guarantee the normal operations of LSI.

The electrical ratings are guaranteed when the device is used within the recommended operating conditions and under the conditions stated for each item.

### 3. Printed Circuit Board Ground Lines Should be Set up with Consideration for Common Impedance

### 4. Take Appropriate Measures Against Static Electricity

- Containers for semiconductor materials should have anti-static protection or be made of conductive material.
- After mounting, printed circuit boards should be stored and shipped in conductive bags or containers.
- Work platforms, tools, and instruments should be properly grounded.
- Working personnel should be grounded with resistance of 250 kΩ to 1MΩ in series between body and ground.

### 5. Do not Apply Negative Voltages

The use of negative voltages below  $-0.3\text{ V}$  may cause the parasitic transistor to be activated on LSI lines, which can cause malfunctions.

## 16. Ordering Information

Part Number	Package	Remarks
MB39A134PFT	24-pin plastic TSSOP (STF024)	-

## 17. RoHS Compliance Information

The LSI products of Cypress with "E1" are compliant with RoHS Directive, and has observed the standard of lead, cadmium, mercury, hexavalent chromium, polybrominated biphenyls (PBB), and polybrominated diphenyl ethers (PBDE). A products whose part number has trailing characters "E1" is RoHS compliant.

### 18. Package Dimension

Package Code: STF024

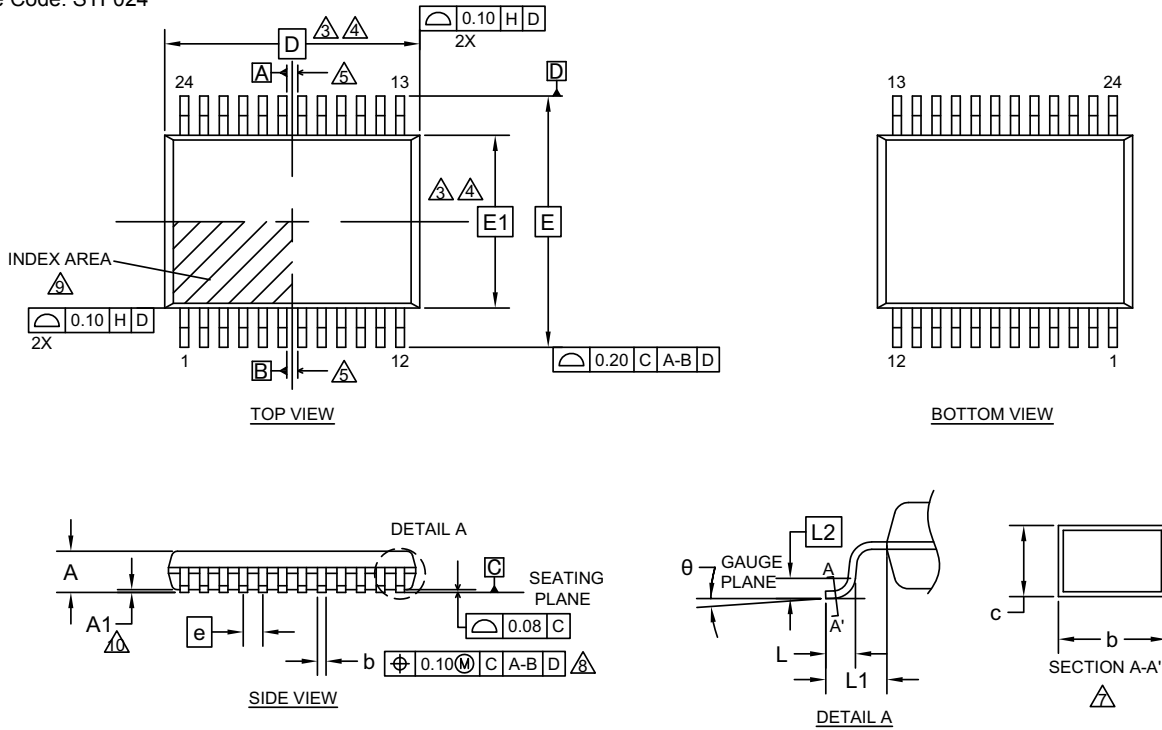

SYMBOL	DIMENSIONS		
	MIN.	NOM.	MAX.
A	—	—	1.10
A1	0.05	—	0.15
D	6.50 BSC		
E	6.40 BSC		
E1	4.40 BSC		
θ	0°	—	8°
c	0.12	—	0.22
b	0.17	0.22	0.27
L	0.45	0.60	0.75
L 1	1.00 REF		
L 2	0.25 BSC		
e	0.50 BSC		

**NOTES**

- ALL DIMENSIONS ARE IN MILLIMETER.
- DIMENSIONING AND TOLERANCING PER ASME Y14.5M-1994.
- DIMENSIONING D INCLUDE MOLD FLASH, DIMENSIONING E1 DOES NOT INCLUDE INTERLEAD FLASH OR PROTRUSION. INTERLEAD FLASH OR PROTRUSIONS SHALL NOT EXCEED 0.025 mm PER SIDE. D and E1 DIMENSION ARE DETERMINED AT DATUM H.
- THE PACKAGE TOP MAY BE SMALLER THAN THE PACKAGE BOTTOM. DIMENSIONING D and E1 ARE DETERMINED AT THE OUTERMOST EXTREMES OF THE PLASTIC BODY EXCLUSIVE OF MOLD FLASH, THE BAR BURRS, GATE BURRS AND INTERLEAD FLASH, BUT INCLUDING ANY MISMATCH BETWEEN THE TOP AND BOTTOM OF THE PLASTIC BODY.
- DATUMS A & B TO BE DETERMINED AT DATUM H.
- "N" IS THE MAXIMUM NUMBER OF TERMINAL POSITIONS FOR THE SPECIFIED PACKAGE LENGTH.
- THE DIMENSION APPLY TO THE FLAT SECTION OF THE LEAD BETWEEN 0.10 mm TO 0.25mm FROM THE LEAD TIP.
- DIMENSION "b" DOES NOT INCLUDE THE DAMBAR PROTRUSION. ALLOWABLE DAMBAR PROTRUSION SHALL BE 0.10mm TOTAL IN EXCESS OF THE "b" DIMENSION AT MAXIMUM MATERIAL CONDITION. THE DAMBAR MAY NOT BE LOCATED ON THE LOWER RADIUS OF THE FOOT.
- THIS CHAMFER FEATURE IS OPTIONAL. IF IT IS NOT PRESENT, THEN A PIN 1 IDENTIFIER MUST BE LOCATED WITHIN THE INDEX AREA INDICATED
- "A1" IS DEFINED AS THE VERTICAL DISTANCE FROM THE SEATING PLANE TO THE LOWEST POINT ON THE PACKAGE BODY EXCLUDING THE LID AND OR THERMAL ENHANCEMENT ON CAVITY DOWN PACKAGE CONFIGURATIONS.
- JEDEC SPECIFICATION NO. REF : N/A

002-15917 Rev. \*\*

## 19. Document History

Document Title: MB39A134 DC/DC converter IC for Charging Li-ion battery Document Number: 002-08413				
Revision	ECN	Orig. of Change	Submission Date	Description of Change
**	-	TAOA	05/22/2008	Migrated to Cypress and assigned document number 002-08413. No change to document contents or format.
*A	5148176	TAOA	03/08/2016	Updated to Cypress template
*B	5626720	HIXT	02/13/2017	Updated <a href="#">Pin Assignment</a> : Change the package name from FPT-24P-M08 to STF024 Updated <a href="#">Ordering Information</a> : Change the package name from FPT-24P-M08 to STF024 Deleted the words, "Lead Free version", in the Remarks. Deleted "Ev Board Ordering Information" Deleted "Marking Format (Lead Free Version)" Deleted "Labeling Sample (Lead Free Version)" Deleted "MB39A134PFT Recommended Conditions Of Moisture Sensitivity Level" Updated <a href="#">Package Dimension</a> : Updated to Cypress format
*C	5703758	AESATMP8	04/20/2017	Updated logo and Copyright.

## Sales, Solutions, and Legal Information

### Worldwide Sales and Design Support

Cypress maintains a worldwide network of offices, solution centers, manufacturer's representatives, and distributors. To find the office closest to you, visit us at [Cypress Locations](#).

#### Products

ARM® Cortex® Microcontrollers	<a href="http://cypress.com/arm">cypress.com/arm</a>
Automotive	<a href="http://cypress.com/automotive">cypress.com/automotive</a>
Clocks & Buffers	<a href="http://cypress.com/clocks">cypress.com/clocks</a>
Interface	<a href="http://cypress.com/interface">cypress.com/interface</a>
Internet of Things	<a href="http://cypress.com/iot">cypress.com/iot</a>
Memory	<a href="http://cypress.com/memory">cypress.com/memory</a>
Microcontrollers	<a href="http://cypress.com/mcu">cypress.com/mcu</a>
PSoC	<a href="http://cypress.com/psoc">cypress.com/psoc</a>
Power Management ICs	<a href="http://cypress.com/pmhc">cypress.com/pmhc</a>
Touch Sensing	<a href="http://cypress.com/touch">cypress.com/touch</a>
USB Controllers	<a href="http://cypress.com/usb">cypress.com/usb</a>
Wireless Connectivity	<a href="http://cypress.com/wireless">cypress.com/wireless</a>

#### PSoC® Solutions

[PSoC 1](#) | [PSoC 3](#) | [PSoC 4](#) | [PSoC 5LP](#) | [PSoC 6](#)

#### Cypress Developer Community

[Forums](#) | [WICED IOT Forums](#) | [Projects](#) | [Video](#) | [Blogs](#) | [Training](#) | [Components](#)

#### Technical Support

[cypress.com/support](http://cypress.com/support)

---

© Cypress Semiconductor Corporation, 2008-2017. This document is the property of Cypress Semiconductor Corporation and its subsidiaries, including Spansion LLC ("Cypress"). This document, including any software or firmware included or referenced in this document ("Software"), is owned by Cypress under the intellectual property laws and treaties of the United States and other countries worldwide. Cypress reserves all rights under such laws and treaties and does not, except as specifically stated in this paragraph, grant any license under its patents, copyrights, trademarks, or other intellectual property rights. If the Software is not accompanied by a license agreement and you do not otherwise have a written agreement with Cypress governing the use of the Software, then Cypress hereby grants you a personal, non-exclusive, nontransferable license (without the right to sublicense) (1) under its copyright rights in the Software (a) for Software provided in source code form, to modify and reproduce the Software solely for use with Cypress hardware products, only internally within your organization, and (b) to distribute the Software in binary code form externally to end users (either directly or indirectly through resellers and distributors), solely for use on Cypress hardware product units, and (2) under those claims of Cypress's patents that are infringed by the Software (as provided by Cypress, unmodified) to make, use, distribute, and import the Software solely for use with Cypress hardware products. Any other use, reproduction, modification, translation, or compilation of the Software is prohibited.

TO THE EXTENT PERMITTED BY APPLICABLE LAW, CYPRESS MAKES NO WARRANTY OF ANY KIND, EXPRESS OR IMPLIED, WITH REGARD TO THIS DOCUMENT OR ANY SOFTWARE OR ACCOMPANYING HARDWARE, INCLUDING, BUT NOT LIMITED TO, THE IMPLIED WARRANTIES OF MERCHANTABILITY AND FITNESS FOR A PARTICULAR PURPOSE. To the extent permitted by applicable law, Cypress reserves the right to make changes to this document without further notice. Cypress does not assume any liability arising out of the application or use of any product or circuit described in this document. Any information provided in this document, including any sample design information or programming code, is provided only for reference purposes. It is the responsibility of the user of this document to properly design, program, and test the functionality and safety of any application made of this information and any resulting product. Cypress products are not designed, intended, or authorized for use as critical components in systems designed or intended for the operation of weapons, weapons systems, nuclear installations, life-support devices or systems, other medical devices or systems (including resuscitation equipment and surgical implants), pollution control or hazardous substances management, or other uses where the failure of the device or system could cause personal injury, death, or property damage ("Unintended Uses"). A critical component is any component of a device or system whose failure to perform can be reasonably expected to cause the failure of the device or system, or to affect its safety or effectiveness. Cypress is not liable, in whole or in part, and you shall and hereby do release Cypress from any claim, damage, or other liability arising from or related to all Unintended Uses of Cypress products. You shall indemnify and hold Cypress harmless from and against all claims, costs, damages, and other liabilities, including claims for personal injury or death, arising from or related to any Unintended Uses of Cypress products.

Cypress, the Cypress logo, Spansion, the Spansion logo, and combinations thereof, WICED, PSoC, CapSense, EZ-USB, F-RAM, and Traveo are trademarks or registered trademarks of Cypress in the United States and other countries. For a more complete list of Cypress trademarks, visit [cypress.com](http://cypress.com). Other names and brands may be claimed as property of their respective owners.

## Looking for pricing, stock, or lifecycle information?

Click below to explore more details on WIN SOURCE:

- ⊖ [View MB39A134PFT-G-BNDE1 on WIN SOURCE](#)
- ⊖ [Infineon Technologies Information](#)

## Optimize Your Supply Chain with WIN SOURCE Solutions

- ✓ Global Sourcing Solution
- ✓ Obsolete Management
- ✓ Cost Control Management
- ✓ Shortage Management
- ✓ Alternative Solution
- ✓ Excess Inventory Management