

Single-chip Type with Built-in FET Switching Regulator Series



# 2-output High-efficiency Step-down Switching Regulators with Built-in Power MOSFET

## BD9302FP

---

### ● Description

The BD9302FP is a 2-channel step-down switching regulator controller with a 2.5-MHz, 2-A power switch and available for 2.5-MHz high speed switching operation, which facilitates settings of switching frequency with external resistance, supporting for a wide input voltage range of 6 to 18 V. Furthermore, due to a low reference voltage of 0.6 V, this BD9302FP is an L/C best suited to high-voltage input/low-voltage output applications, for example, to step down a voltage from 12 V to 1.2 V.

### ● Features

- 1) A wide input voltage range of 6 V to 18 V
- 2) Easy switching frequency setting in the range of 200 k to 2.5 MHz.
- 3) Two built-in power switches of 0.4  $\Omega$ , 2 A.
- 4) 180° phase shift
- 5) Built-in Under Voltage Lock Out circuit
- 6) Built-in overcurrent protection circuit
- 7) Built-in Thermal Shutdown circuit

### ● Use

Power supply for DPS requiring two power sources  
ADSL modem/plasma display  
Audio devices

● Absolute maximum ratings (Ta=25°C)

Item	Symbol	Rating	Unit
Power supply voltage	Vcc	20	V
Power dissipation	Pd	1450*	mW
Operating temperature	Topr	-40 ~ +85	°C
Storage temperature	Tstg	-55 ~ +150	°C
Output current	Io	2**	A
Maximum junction temperature	Tjmax	150	°C

\* Should be derated by 11.6 mW/°C at Ta=25°C or more. When mounted on a glass epoxy PCB of 70 70 1.6 mm)

\*\* Should not exceed Pd-value.

● Recommended operating range (Ta=25°C)

Item	Symbol	Limits			Unit
		Min	Typ	Max	
Power supply voltage	Vcc	6	12	18	V
Output current	Io	—	—	1.8	A
Timing resistance	RT	10	—	100	kΩ
Oscillation frequency	Fosc	100	—	2500	kHz

● Electrical characteristics

○ Electrical characteristics (Unless otherwise specified, Ta=25°C, Vcc=12 V, RT=10 kΩ)

Item	Symbol	Limits			Unit	Conditions
		Min	Typ	Max		
[Triangular wave oscillator block]						
Oscillation frequency	Fosc	1800	2000	2200	kHz	RT=10kΩ
Frequency variation	F <sub>DVO</sub>	—	1	—	%	~ 18V
[Overcurrent protection circuit block]						
Overcurrent limit	I <sub>sw</sub>	2	4	6	A	*
[Under-voltage malfunction prevention circuit block]						
Upper limit threshold voltage	V <sub>tH</sub>	3.0	3.3	3.6	V	
Lower limit threshold voltage	V <sub>tL</sub>	2.7	3.0	3.3	V	
[Soft start circuit block]						
Source current	I <sub>SSO</sub>	6	10	14	uA	V <sub>SS</sub> =1V
Sink current	I <sub>SSI</sub>	0.6	1.7	5	mA	V <sub>SS</sub> =1V, V <sub>CC</sub> =3V
Clamp voltage	V <sub>cl</sub>	1.75	1.95	2.15	V	
Shutdown voltage	V <sub>SDWN</sub>	—	—	0.3	V	V <sub>CC</sub> =3V

○ Not designed for radiation resistance.

\* Design guarantee (No 100% pre-shipment inspections are conducted.)

● Electrical characteristics

○ Electrical characteristics (Unless otherwise specified,  $T_a=25^\circ\text{C}$ ,  $V_{cc}=12\text{ V}$ ,  $R_T=10\text{ k}\Omega$ )

Item	Symbol	Limits			Unit	Conditions
		Min	Typ	Max		
[Error amplifier block]						
Input bias current	$I_{IB}$	–	0.4	1	$\mu\text{A}$	
Voltage gain	$A_V$	–	200	–	V/V	
COMP maximum output voltage	$V_{OH}$	1.75	1.95	–	V	$I_{COMP} = -0.1\text{mA}$
COMP minimum output voltage	$V_{OL}$	–	0.8	1.0	V	$I_{COMP} = 0.1\text{mA}$
Output sink current	$I_{OI}$	1	2	4	mA	$V_{FB} = 0.8\text{V}$
Output source current	$I_{OO}$	– 8	– 4	– 1	mA	$V_{FB} = 0.4\text{V}$
Feedback voltage	$V_{FB}$	0.588	0.600	0.612	V	Buffer
[Output block]						
Upper-side ON resistance	$R_{onh}$	–	0.4	0.6	$\Omega$	$I_o = 1\text{A}^*$
Low-side ON resistance	$R_{onl}$	0.1	2	3	$\Omega$	$I_o = 20\text{mA}^*$
OFF current	$I_{OFF}$		0.2	0.4	mA	$SW = 0\text{V}$
[Total device]						
Average supply current	$I_{CC}$	–	5	–	mA	$R_T = 1.0\text{V}$

○ Not designed for radiation resistance.

\* Design guarantee (No 100% pre-shipment inspections are conducted.)

● Measurement circuit diagram

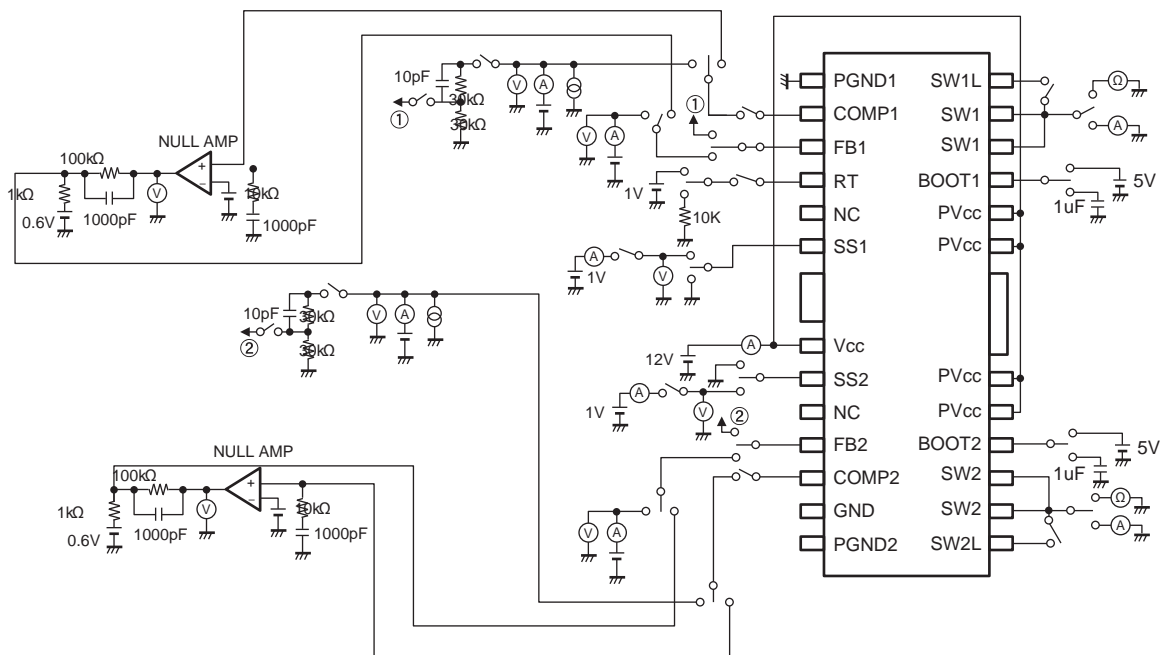

Fig. 1 Typical measurement circuit

● Reference characteristics data

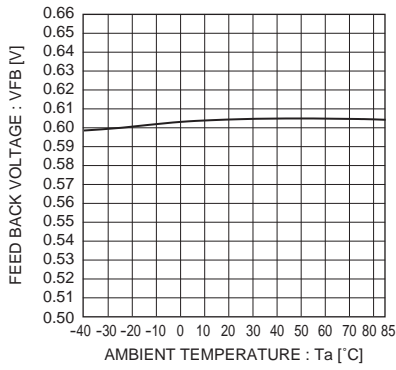

Fig.2  
Feedback voltage –  
Ambient temperature

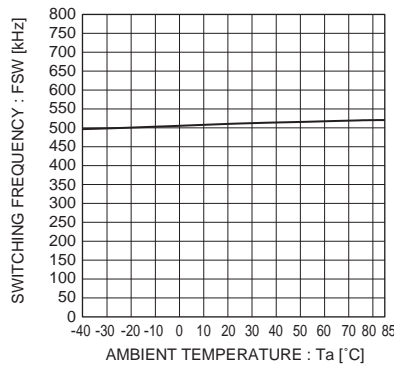

Fig.3  
Switching frequency –  
Ambient temperature

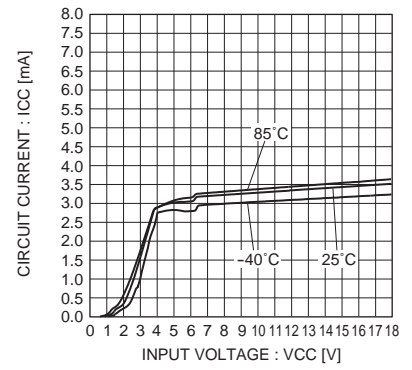

Fig.4  
Power supply voltage –  
Circuit current

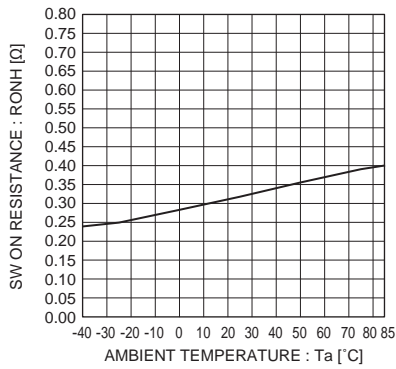

Fig.5  
SW ON resistance –  
Ambient temperature

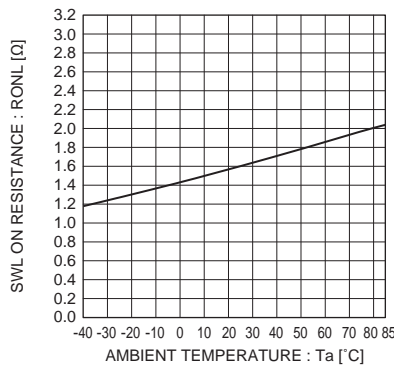

Fig.6  
SWL ON resistance –  
Ambient temperature

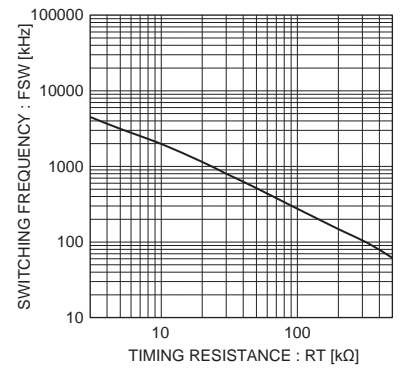

Fig.7  
Setting resistance –  
Switching frequency

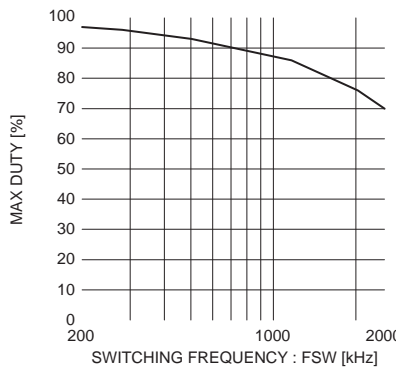

Fig.8  
Switching frequency – MAX Duty

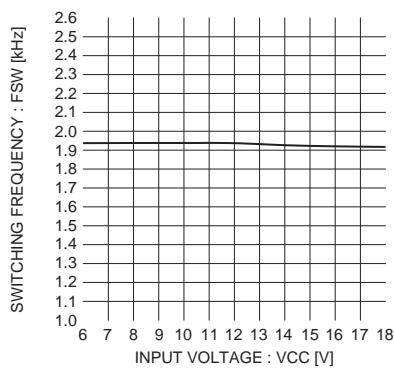

Fig.9  
Switching frequency – Power supply voltage

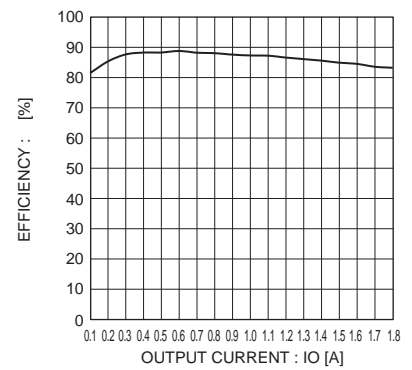

Fig.10  
Output current – Efficiency

(\*) The data shown above represent real values sampled but not guarantee values.

● Reference characteristics data

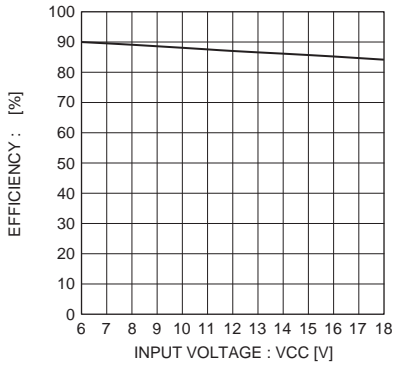

Fig.11  
Power supply voltage – Efficiency

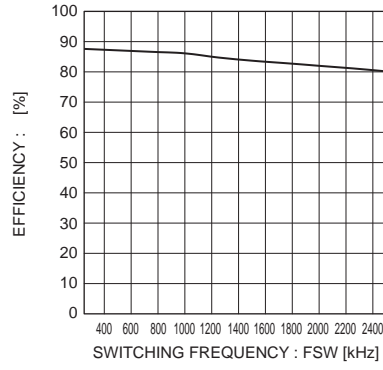

Fig.12  
Switching frequency – Efficiency

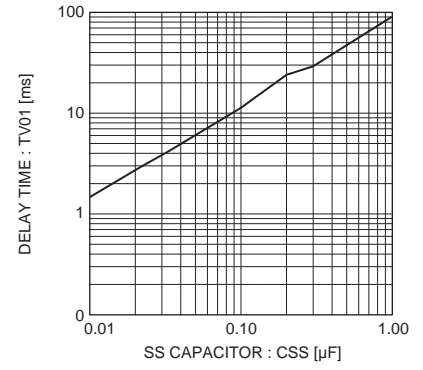

Fig.13  
Set capacitance – Delay time

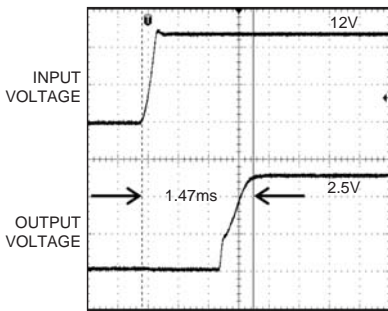

Fig.14  
Startup waveform

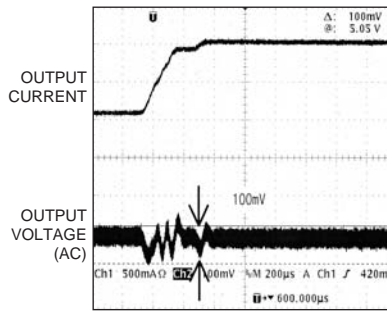

Fig.15  
Load transient response No. 1

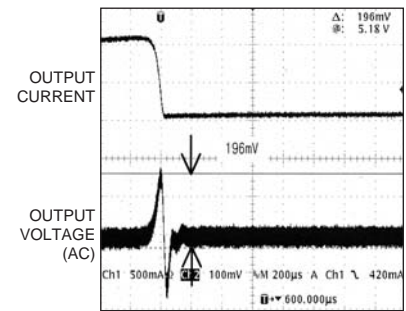

Fig.16  
Load transient response No. 2

● Application measurement circuit diagram

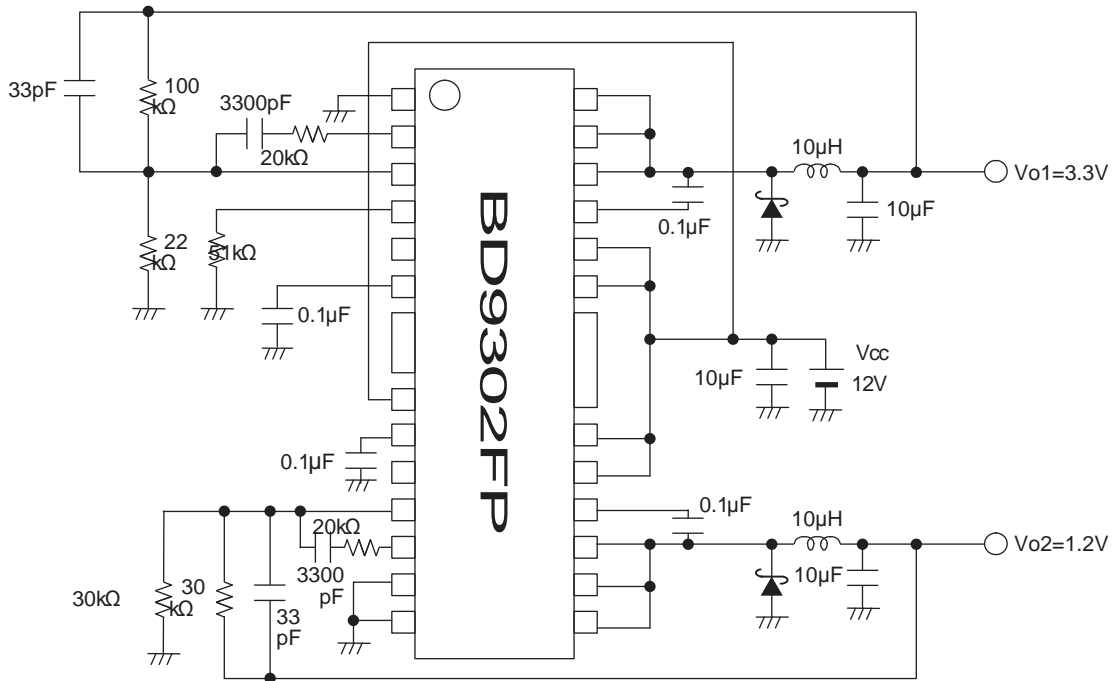
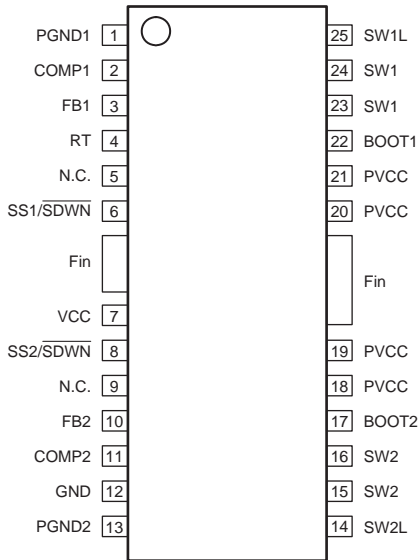

Fig.17 Application measurement circuit diagram

(\*) The data shown above represent real values sampled but not guarantee values.

● Pin assignment



● Block diagram

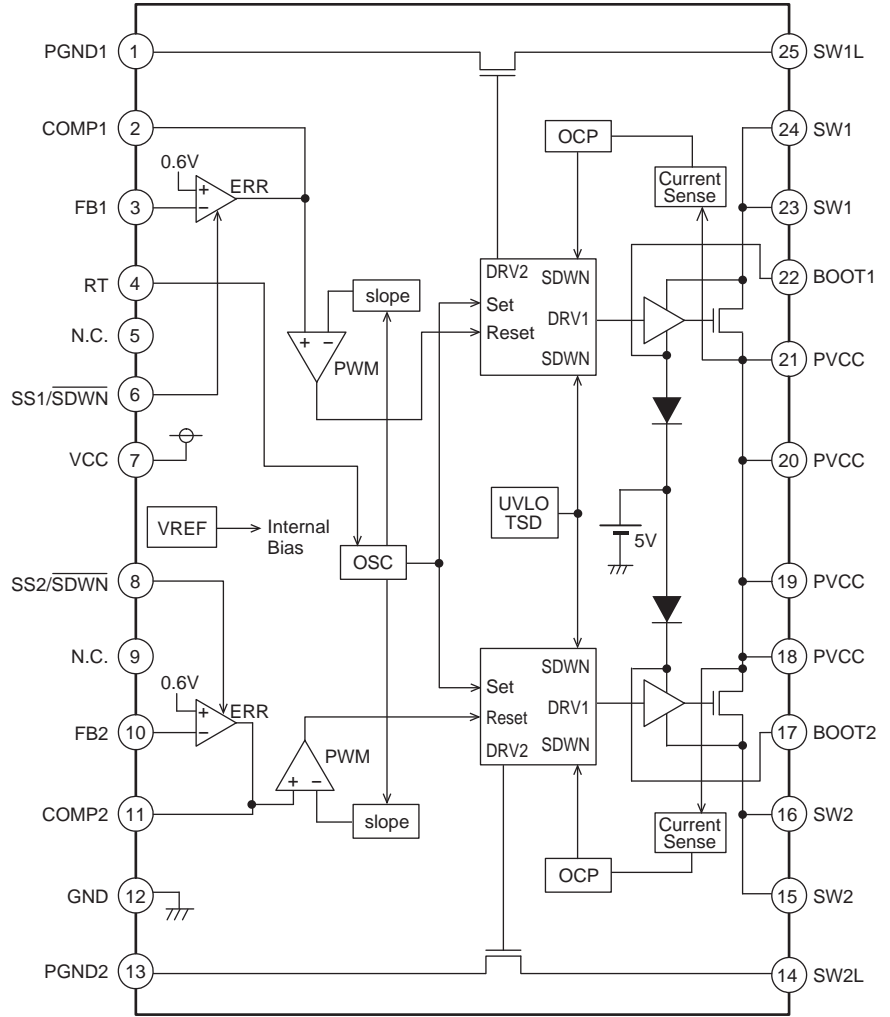

Fig.18 Pin assignment / Block diagram

TOP VIEW

● Pin assignment / functions

Pin No.	Pin name	Function
1	PGND1	Ground
2	COMP1	Error amplifier output
3	FB1	Error amplifier inverting input
4	RT	Frequency setting resistor connection
5	—	N.C.
6	SS1/SDWN	Soft start capacitor connection (Shutdown at Low)
7	VCC	Power supply input
8	SS2/SDWN	Soft start capacitor connection (Shutdown at Low)
9	—	N.C.
10	FB2	Error amplifier inverting input
11	COMP2	Error amplifier output
12	GND	Ground

Pin No.	Pin name	Function
13	PGND2	Ground
14	SW2L	Switching output 2 (Low side)
15	SW2	Switching output 2
16	SW2	Switching output 2
17	BOOT2	Boot capacitor connection
18	Pvcc	Power supply input
19	Pvcc	Power supply input
20	Pvcc	Power supply input
21	Pvcc	Power supply input
22	BOOT1	Boot capacitor connection
23	SW1	Switching output 1
24	SW1	Switching output 1
25	SW1L	Switching output 1 (Low side)

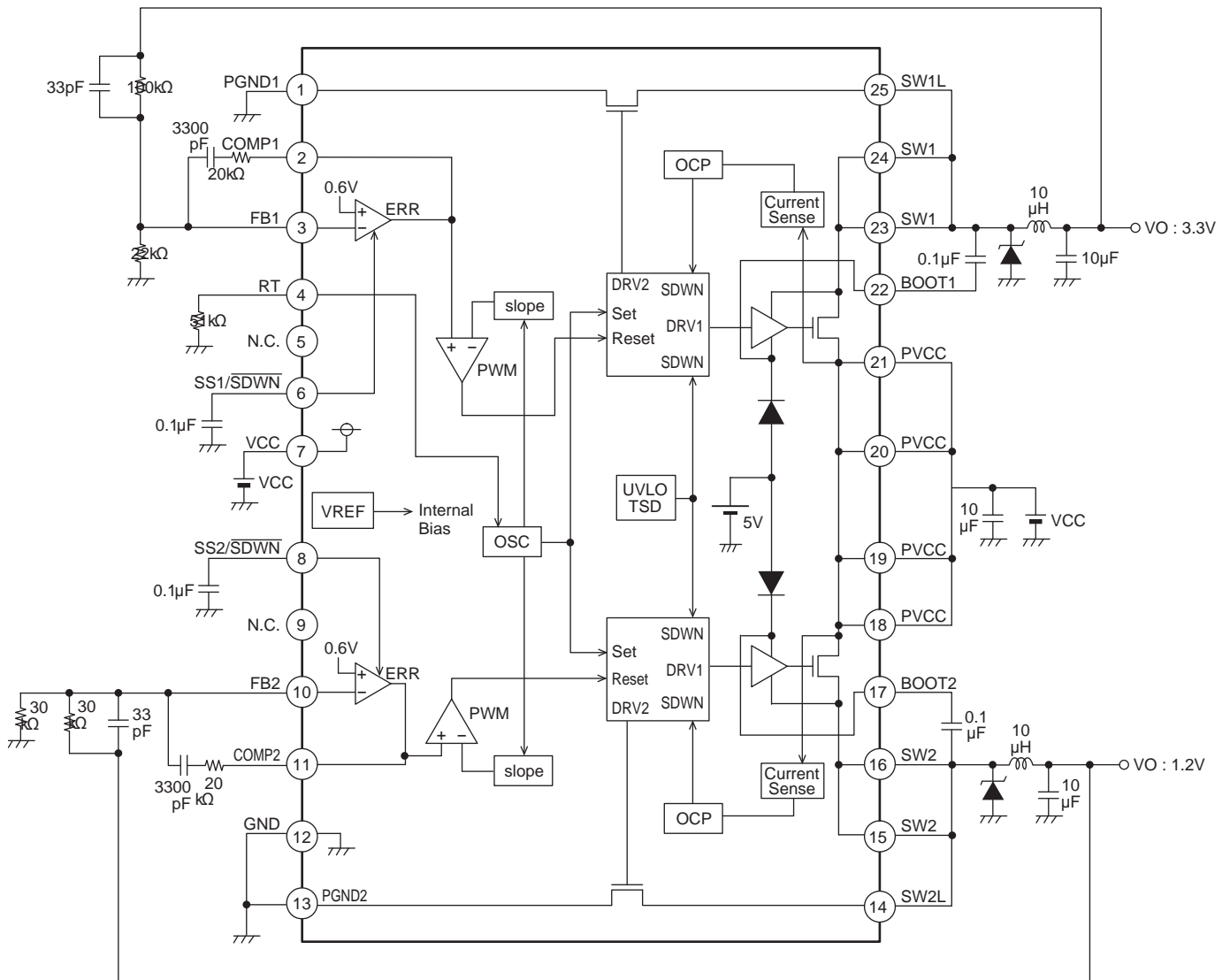

Fig.19 Typical application circuit

ü Error amplifier (ERR) block

The ERR block is a circuit used to compare between the 0.6-V reference voltage and the feedback voltage of output voltage. The COMP voltage, a result of this comparison, determines the switching Duty. Furthermore, soft start function is activated with the SS voltage while in startup operation. Consequently, the COMP voltage is limited to the SS voltage.

ü Oscillator (OSC) block

The OSC block is a block to determine the switching frequency through the RT pin, which is settable in the range of 100 kHz to 2500 kHz.

ü SLOPE block

The SLOPE block is a block to generate a triangular wave from the clock generated with the OSC and then to transmit the triangular wave to the PWM comparator.

ü PWM block

The PWM block is used to make comparison between the output COMP voltage of the error amplifier block and the triangular wave of the SLOPE block, thus determining the switching Duty. The switching duty is limited with the maximum duty ratio, which is internally determined, and will not reach 100%.

ü Reference voltage (UREF) block

The UREF block is a block to generate a 2.9-V internal reference voltage.

ü Protection circuit (UVLO/TSD) block

The UVLO (Under Voltage Lock Out) circuit is used to shut down the circuit when the voltage falls below approximately 3.3 V, while the TSD (Thermal Shutdown) circuit is used to shut down the circuit at a temperature of 175°C and reset it at a temperature of 160°C.

ü Overcurrent protection circuit (OCP)

This function is used to detect a current passing through the power transistor FET with the CURRENT SENSE and activate the overcurrent protection when the current reaches approximately 4 A. If the overcurrent protection is activated, switching will be turned OFF to discharge the SS pin capacitance.

● Timing chart

Startup sequence

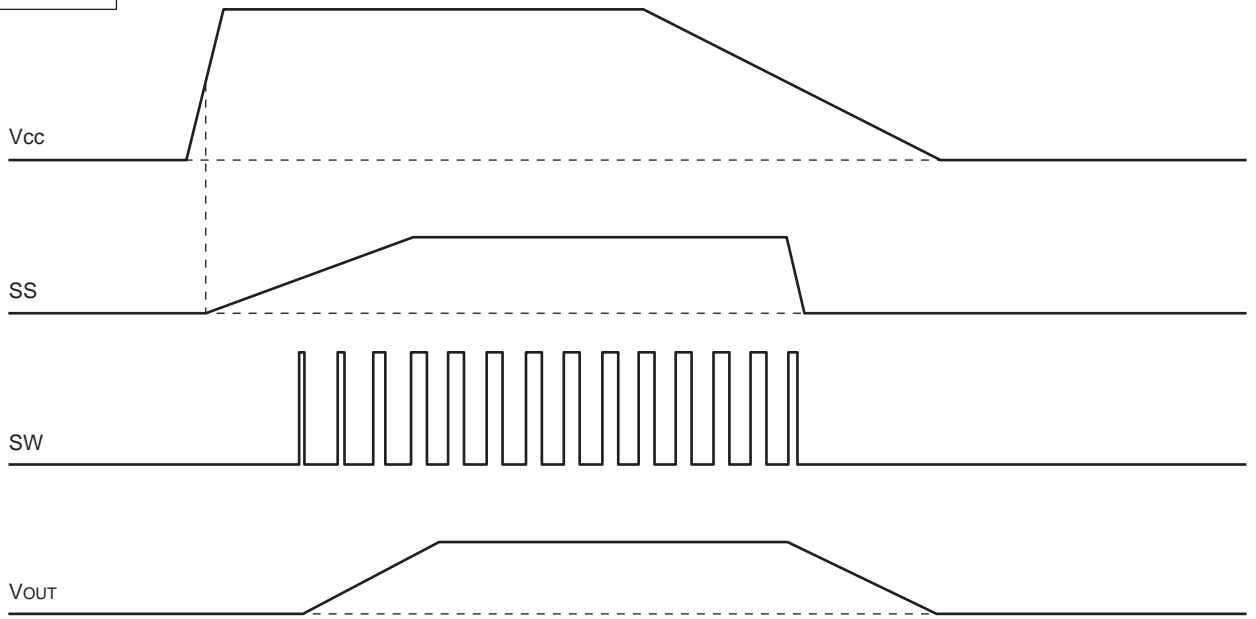

Fig.20 Startup sequence

Normal operation

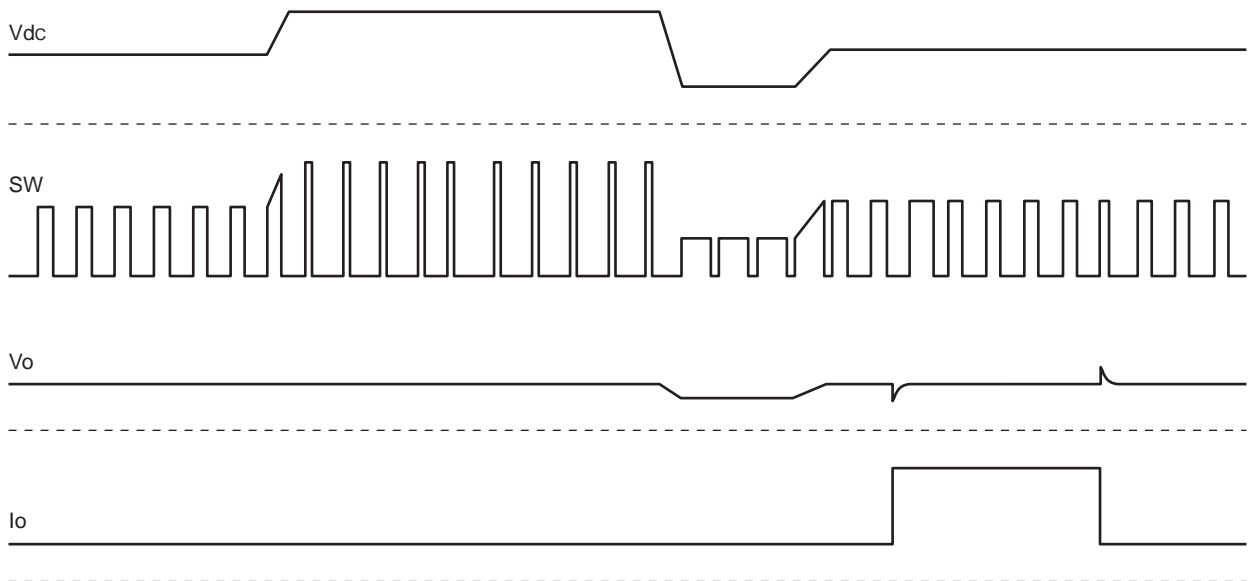

Fig.21 While in normal operation

● External component setting procedure

(1) Setting of output L constant

The coil L used for output is determined according to the rated current  $I_{LR}$  and the maximum load current value  $I_{OMAX}$  of the coil.

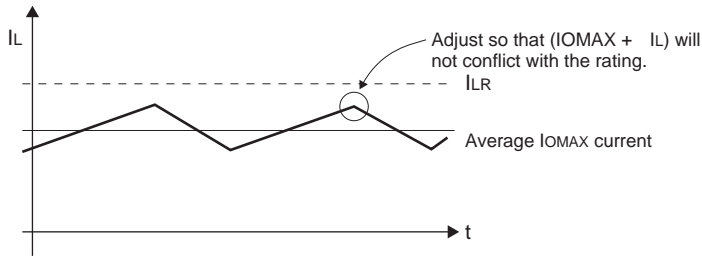

Fig.22

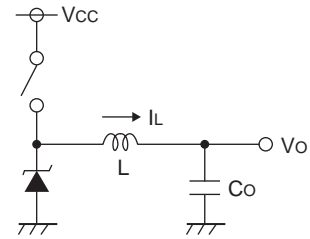

Fig.23

Adjust so that  $(I_{OMAX} + DIL)$  will not conflict with the rating. At this time,  $DIL$  can be obtained according to the formula shown below.

Step-down 
$$I_L = \frac{1}{L} (V_{CC} - V_o) \frac{V_o}{V_{CC}} \frac{1}{f} \text{ [A]} \dots (1.1)$$
 , where f: Switching frequency

Furthermore, since the coil L value may also vary by approximately  $\pm 30\%$ , set this value with an adequate margin. If the coil current  $I_L$  exceeds the rated coil current  $I_{LR}$ , the internal IC element may be damaged. It is recommended to make setting of coil value in the range of  $4.7 \mu\text{F}$  to  $100 \mu\text{F}$ .

(2) Setting of output  $C_o$  constant

For output capacitor, select the allowable ripple voltage  $V_{PP}$  or the allowable drop voltage at a sharp change of load, whichever larger for the capacitor. The output ripple voltage can be obtained according to the formula shown below.

Step-down 
$$V_{PP} = I_L R_{ESR} + \frac{I_L}{2C_o} \frac{V_o}{V_{CC}} \frac{1}{f} \text{ [V]}$$
 , where f: Switching frequency

Design the component so that this constant will fall within the allowable ripple voltage. Furthermore, estimate the drop voltage  $V_{DR}$  at a sharp change of load according to the formula shown below.

$$V_{DR} = \frac{I}{C_o} 10\mu\text{sec} \text{ [V]}$$

However,  $10 \mu\text{sec}$  will be the estimated value of the DC/DC converter response speed.

Make setting of capacitance with thorough consideration given to the margin so that these two values will fall into the specified values. It is recommended to make setting of the capacitance in the range of  $10 \mu\text{F}$  to  $100 \mu\text{F}$ . if a short circuit occurs, an inverse current passes through the parasitic diode to cause damage to the internal circuits. To prevent that, insert a backflow prevention diode.

(3) Setting of feedback resistance constant

In order to make settings of feedback resistance, refer to the formula shown. It is recommended to make setting of resistance in the range of 10 kΩ to 330 kΩ. Setting the resistance to 10 kΩ or less will result in degraded power efficiency, while setting it to 330 kΩ or more will increase the offset voltage due to the input bias current of 0.4 μA (TYP) of the internal error amplifier.

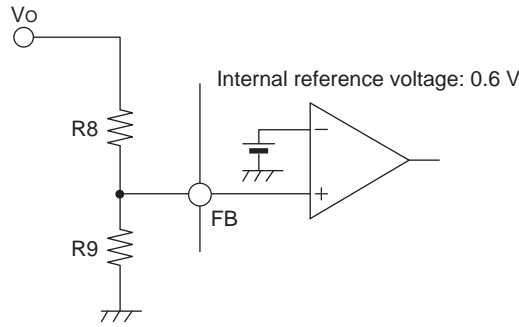

Fig.24

$$V_o = \frac{R8+R9}{R9} \cdot 0.6 \text{ [V]}$$

(4) Setting of oscillation frequency

Connecting a resistor to the RT pin (pin 4) will allow for the setting of triangular wave oscillation frequency. The RT determines the charge/discharge current to the internal capacitor, with which the frequency varies. Referring to Figure shown below, make settings of the RT resistor. Recommended setting range is 10 to 100 kΩ. Be noted that any setting outside of this range may turn OFF switching, thus impairing the operation guarantee.

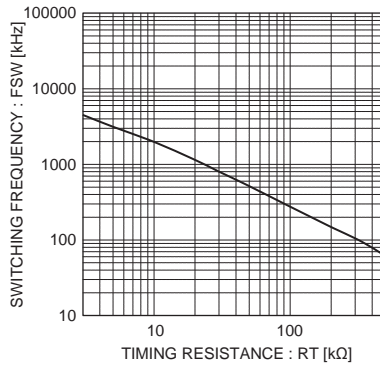

Fig.25 RT vs. Switching frequency

(5) Setting of soft start time

The soft start function will be required to prevent an excessive increase in the coil current and overshoot of the output voltage, while in startup operation. Figure below shows the relationship between the capacitor and the soft start time. Referring to this Figure, make the capacitor setting.

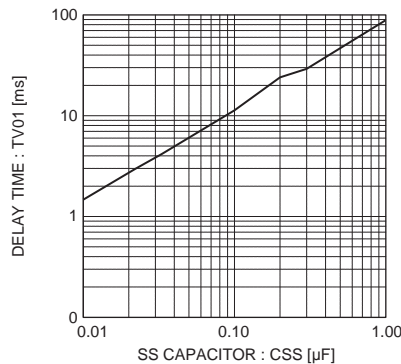

Fig.26 SS capacitance vs. Delay time

It is recommended to make setting of capacitance value in the range of 0.01 to 10 μF. Setting the capacitance value to 0.01 μF or less may cause overshoot to the output voltage. If any startup-related function (sequence) of other power supply is provided, use a high-accuracy product (e.g. 5R) or the like.

Furthermore, since the soft start time varies with the input voltage, output voltage, load, coil, output capacitor, or else, be sure to check to be sure this soft start time on the actual system.

(6) Phase compensation

Phase compensation setting procedure

The phase compensation setting procedure varies with the selection of capacitance used for DC/DC converter application. In this connection, the following section describes the procedure by classifying into the two types. Furthermore, the application stability conditions are described in the “Description” section.

1. Application stability conditions
2. For output capacitors having high ESR, such as electrolytic capacitor
3. For output capacitors having low ESR, such as ceramic capacitor or OS-CON

About application stability conditions

The following section shows the stability conditions of negative feedback system.

- ü At a 1 (0-dB) gain, the phase delay is 150° or less (i.e., the phase margin is 30° or more).

Furthermore, since the DC/DC converter application is sampled according to the switching frequency, GBW of the overall system should be set to 1/10 or less of the switching frequency. The following section summarizes the targeted characteristics of this application.

- ü At a 1 (0-dB) gain, the phase delay is 150° or less (i.e., the phase margin is 30° or more).
- ü The GBW (i.e., frequency at 0-dB gain) for this occasion is 1/10 or less of the switching frequency.

Consequently, in order to upgrade the responsiveness, higher switching frequency should be provided.

A knack for ensuring the stability through the phase compensation is to cancel a secondary phase delay (-180°) resulting from LC resonance with a secondary phase lead (i.e., through inserting two phase leads). Furthermore, the GBW (i.e., frequency at 0-dB gain) is determined according to phase compensation capacitance to be provided for the error amplifier. Consequently, in order to reduce the GBW, increase the capacitor capacitance.

(1) Typical (sun) integrator (Low pass filter)

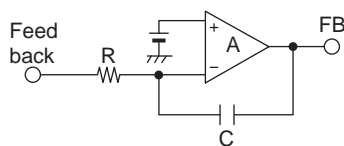

Fig.27

(2) Open loop characteristics of integrator

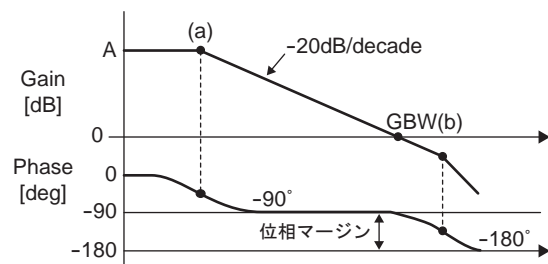

Fig.28

$$\text{Point (a) } f_a = \frac{1}{2 RCA} \cdot 1.25 \text{ [Hz]}$$

$$\text{Point (b) } f_a = \text{GBW} \cdot \frac{1}{2 RC} \text{ [Hz]}$$

Since the error amplifier is provided with (1) or (2) phase compensation, the low pass filter is applied. In the case of the DC/DC converter application, the R becomes a parallel resistance of the feedback resistance.

For output capacitors having high ESR, such as aluminum electrolytic capacitor

For output capacitors having high ESR (i.e., several ohms), the phase compensation setting procedure becomes comparatively simple. Since the DC/DC converter application has surely a LC resonant circuit attached to the output, a  $-180^\circ$  phase-delay occurs in that area. If ESR component is present there, however, a  $+90^\circ$  phase-lead occurs to shift the phase delay to  $-90^\circ$ . Since the phase delay is desired to set within  $150^\circ$ , this is a very effective method but has a demerit to increase the ripple component of the output voltage.

(3) LC resonant circuit

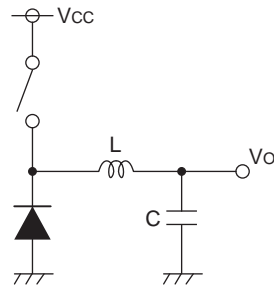

$$f_r = \frac{1}{2\sqrt{LC}} \text{ [Hz]}$$

At this resonance point, a  $-180^\circ$  phase-delay occurs.

Fig.29

(4) With ESR provided

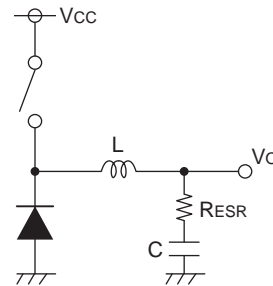

$$f_r = \frac{1}{2\sqrt{LC}} \text{ [Hz]: Resonance point}$$

$$f_{ESR} = \frac{1}{2\sqrt{R_{ESR}C}} \text{ [Hz]: Phase lead}$$

A  $-90^\circ$  phase-delay occurs.

Fig.30

According to changes in phase characteristics due to the ESR, only one phase lead should be inserted. For this phase lead, select either of the methods shows below.

(5) Insert feedback resistance in the C.

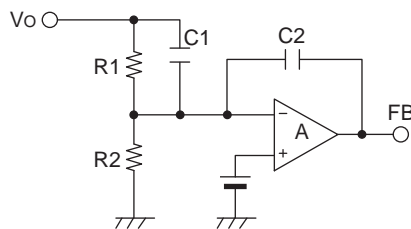

$$\text{Phase lead: } f_z = \frac{1}{2\sqrt{C_1 R_1}} \text{ [Hz]}$$

Fig.31

(6) Insert the R3 in integrator.

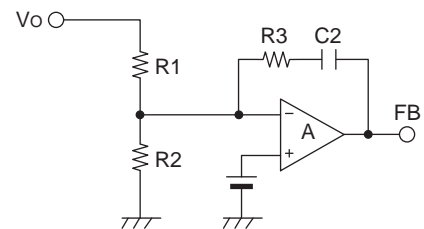

$$\text{Phase lead: } f_z = \frac{1}{2\sqrt{C_2 R_3}} \text{ [Hz]}$$

Fig.32

For the purpose of canceling the LC resonance, the frequency to insert the phase lead should be set close to the LC resonant frequency.

For output capacitors having low ESR, such as ceramic capacitor or OS-CON

Unlike the section above, in order to use capacitors having low ESR (i.e., several tens of mW), two phase-leads should be inserted so that a  $-180^\circ$  phase-delay due to LC resonance will be observed. Example (7) below shows a typical phase compensation procedure.

(7) Phase compensation with secondary phase lead

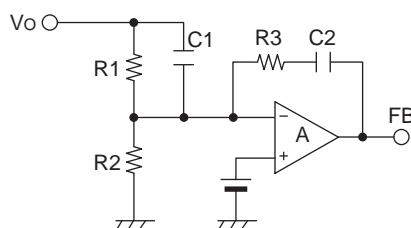

$$\text{Phase lead: } f_{z1} = \frac{1}{2\sqrt{R_1 C_1}} \text{ [Hz]}$$

$$\text{Phase lead: } f_{z2} = \frac{1}{2\sqrt{R_3 C_2}} \text{ [Hz]}$$

$$\text{LC resonant frequency: } f_r = \frac{1}{2\sqrt{LC}} \text{ [Hz]}$$

Fig.33

For the settings of phase lead frequency, insert both of the phase leads close to the LC resonant frequency.

● Equivalent circuit

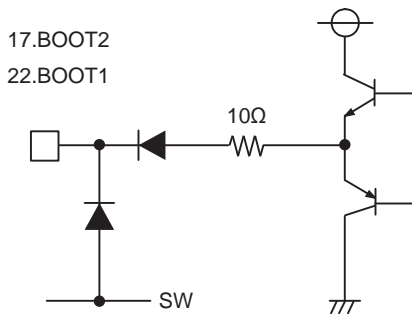
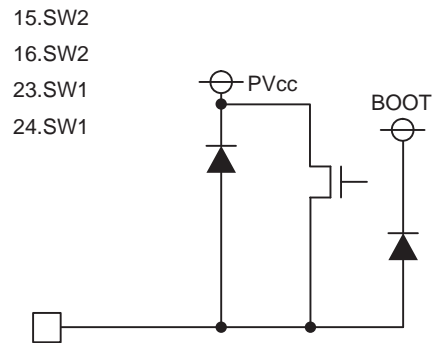
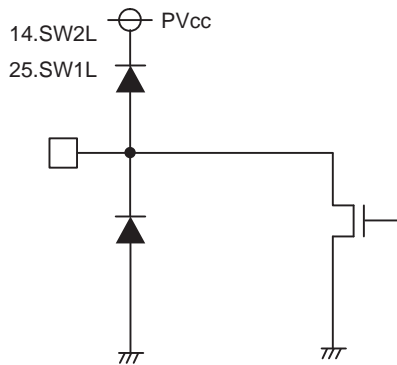
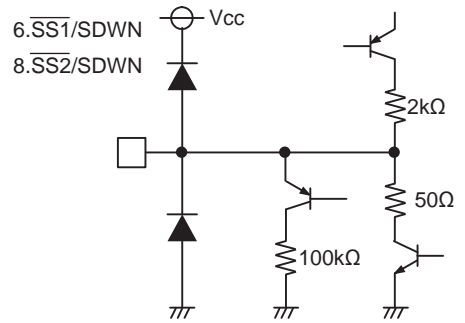
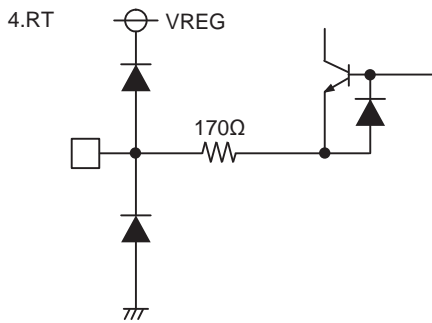
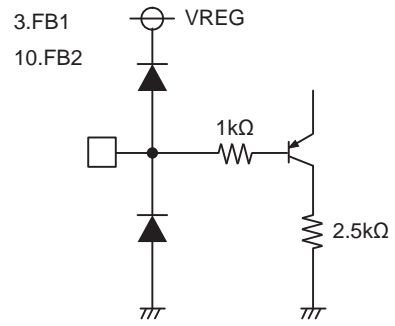
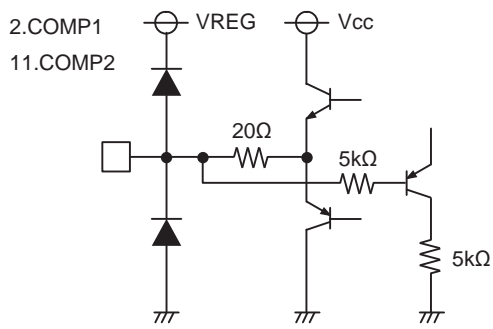

Fig.34 Equivalent circuit

● Cautions on use

- 1) Absolute maximum ratings  
Even though thorough attention is exerted to the quality control of this IC, exceeding the absolute maximum ratings, such as applied voltage, operating temperature range, etc., can break down the IC. Should the IC break down, it will be impossible to identify breaking mode such as short circuit mode or an open mode. If any special mode exceeding the absolute maximum ratings is assumed, consideration should be given to take physical safety measures including use of fuses, etc.
- 2) GND potential  
GNDMake setting of the potential of the GND terminal so that it will be maintained at the minimum in any operating state.
- 3) Thermal design  
With consideration given to power dissipation (Pd) in the actual use state, provide the thermal design with an adequate margin.
- 4) Short circuit between pins and erroneous mounting  
In order to mount ICs on a set printed circuit board, pay thorough attention to the direction and offset of the ICs. Erroneous mounting can break down the ICs. Furthermore, if a short circuit occurs due to foreign matters entering between pins or between the pin and the power supply or the GND pin, the ICs can break down.
- 5) Operation in strong electromagnetic field  
Be noted that using ICs in the strong electromagnetic field can malfunction them.
- 6) Inspection with set printed circuit board  
On the inspection with the set printed circuit board, if a capacitor is connected to a low-impedance pin, the IC can suffer stress. Therefore, be sure to discharge from the set printed circuit board by each process. For protection against static electricity, establish a ground for the assembly process and pay thorough attention to the transportation and the storage of the set printed circuit board. Furthermore, in order to connect the jig for the inspection process, be sure to turn OFF the power supply and then mount the set printed circuit board to the jig. After the completion of the inspection, be sure to turn OFF the power supply and then dismount the set printed circuit board from the jig.
- 7) IC pin input  
This IC is a monolithic IC, which has P+ isolation and P layer between elements to isolate the elements. P-N junction is formed with this P layer and the N layer of each element, thus composing a variety of parasitic elements.  
For example, as shown in Fig. 35, if the resistor and the transistor is connected with the pin respectively,  
○When GND>(Pin A) for the resistor or GND>(Pin B) for the transistor (NPN), P-N junction will operate as a parasitic diode.  
○For the transistor (NPN), when GND>(Pin B), the parasitic NPN transistor will operate with the N layer of other element in the proximity of the said parasitic diode.

In terms of the construction of IC, parasitic elements are inevitably formed in relation to potential. The operation of the parasitic element can cause interference with circuit operation, thus resulting in a malfunction and then breakdown of the IC. Therefore, pay thorough attention not to handle the input pins such as to apply to the input pins a voltage lower than the GND (P layer) so that any parasitic element will operate.

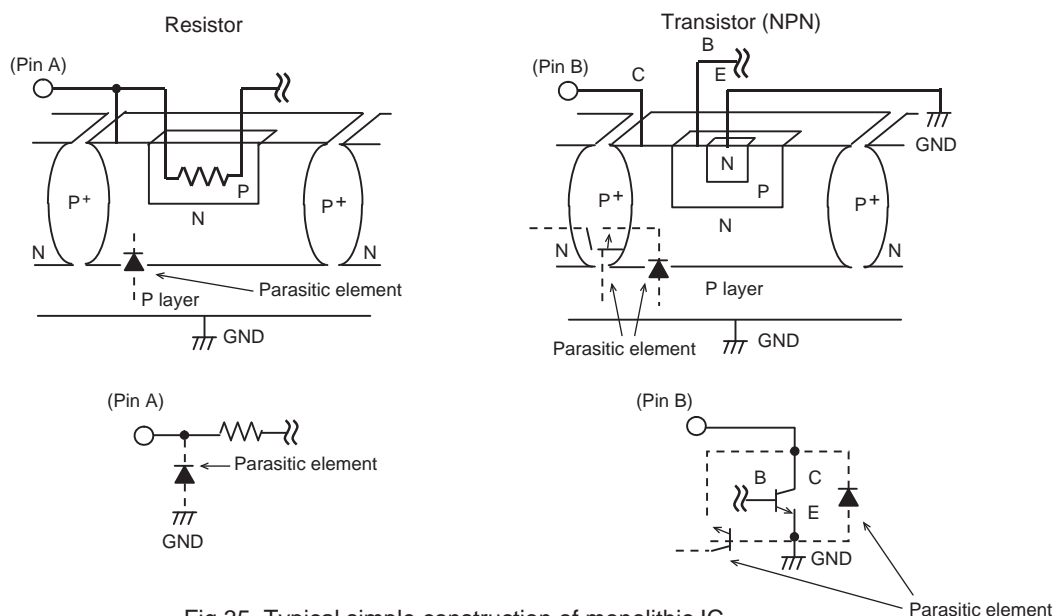

Fig.35 Typical simple construction of monolithic IC

8) Ground wiring pattern

If small-signal GND and large-current GND are provided, It will be recommended to separate the large-current GND pattern from the small-signal GND pattern and establish a single ground at the reference point of the set PCB so that resistance to the wiring pattern and voltage fluctuations due to a large current will cause no fluctuations in voltages of the small-signal GND. Pay attention not to cause fluctuations in the GND wiring pattern of external parts as well.

9) On the application shown on the right, if the VCC and each output voltage are inverted, for example, if the VCC is short-circuited to the Ground with external diode charged, internal circuits or elements may be damaged. To avoid that, use the output pin capacitor in the range of 10 to 100  $\mu\text{F}$ . Furthermore, in order to use a capacitor of 100  $\mu\text{F}$  or more, it is recommended to insert a backflow prevention diode or a bypass diode between the output and VCC.

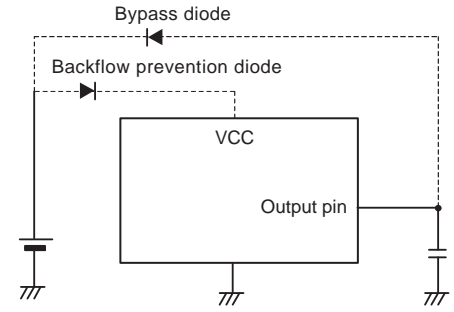

Fig.36 Typical bypass diode application

10) Overcurrent protection circuit

Output has a built-in overcurrent protection circuit according to the current capability, which prevents the destruction of the IC at short-circuiting of load. However, this protection circuit is only effective to prevent destruction due to a sudden accident but does not support for the continuous operation of the protection circuit or use in transition. Furthermore, since the current capability has characteristic negative to temperature, give consideration to the thermal design.

11) Temperature protection circuit

This IC has a built-in temperature protection circuit to prevent the thermal destruction of the IC. As described above, be sure to use this IC within the power dissipation range. Should a condition exceeding the power dissipation range continues, the chip temperature  $T_j$  will rise to activate the temperature protection circuit, thus turning OFF the output power element. Then, when the tip temperature  $T_j$  falls, the circuit will be automatically reset. Furthermore, since the temperature protection circuit is activated under the condition exceeding the absolute maximum ratings, NEVER attempt to use the temperature protection circuit for set design or else.

12) Input capacitor

In order to derate a peak noise, which occurs while in switching operation, be sure to insert a capacitor (ceramic capacitor) having a low ESR of 10 to 100  $\mu\text{F}$  as close to the pin as possible between the VCC and Ground.

● Power dissipation

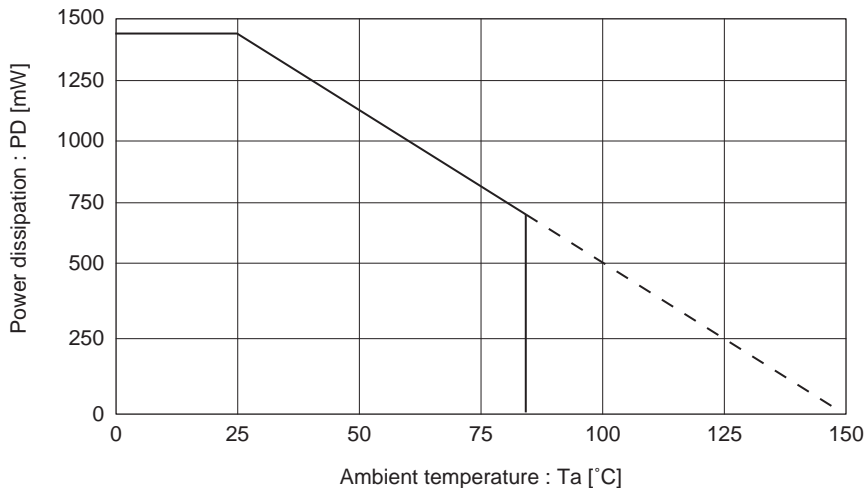
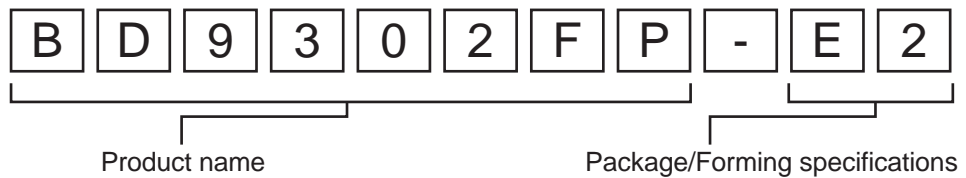

Fig.37 Thermal derating characteristics

● Selection of order type



● Package specifications

HSOP25

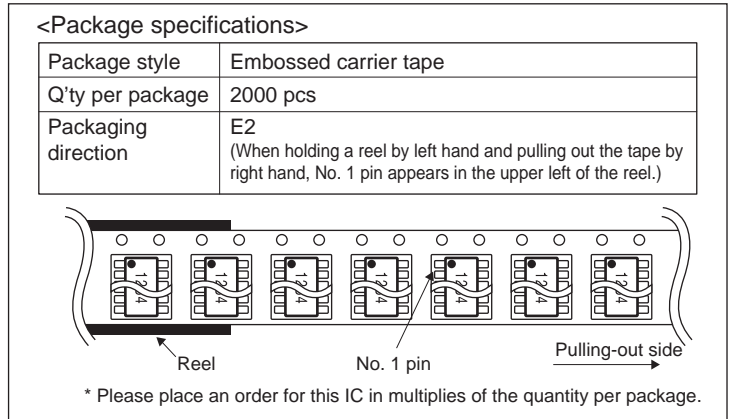
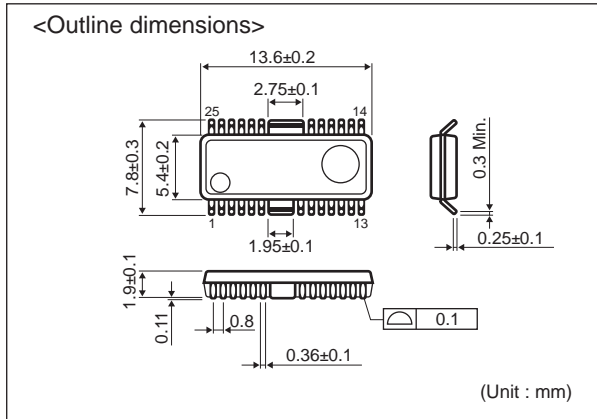

- The contents described herein are correct as of December, 2008
- The contents described herein are subject to change without notice. For updates of the latest information, please contact and confirm with ROHM CO.,LTD.
- Any part of this application note must not be duplicated or copied without our permission.
- Application circuit diagrams and circuit constants contained herein are shown as examples of standard use and operation. Please pay careful attention to the peripheral conditions when designing circuits and deciding upon circuit constants in the set.
- Any data, including, but not limited to application circuit diagrams and information, described herein are intended only as illustrations of such devices and not as the specifications for such devices. ROHM CO.,LTD. disclaims any warranty that any use of such devices shall be free from infringement of any third party's intellectual property rights or other proprietary rights, and further, assumes no liability of whatsoever nature in the event of any such infringement, or arising from or connected with or related to the use of such devices.
- Upon the sale of any such devices, other than for buyer's right to use such devices itself, resell or otherwise dispose of the same, implied right or license to practice or commercially exploit any intellectual property rights or other proprietary rights owned or controlled by ROHM CO., LTD. is granted to any such buyer.
- The products described herein utilize silicon as the main material.
- The products described herein are not designed to be X ray proof.

The products listed in this catalog are designed to be used with ordinary electronic equipment or devices (such as audio visual equipment, office-automation equipment, communications devices, electrical appliances and electronic toys). Should you intend to use these products with equipment or devices which require an extremely high level of reliability and the malfunction of which would directly endanger human life (such as medical instruments, transportation equipment, aerospace machinery, nuclear-reactor controllers, fuel controllers and other safety devices), please be sure to consult with our sales representative in advance.

R0118A

Excellence in Electronics



ROHM CO., LTD.

21 Saiin Mizosaki-cho, Ukyo-ku, Kyoto  
615-8585, Japan  
TEL: +81-75-311-2121 FAX: +81-75-315-0172  
URL: <http://www.rohm.com>

Published by  
KTC LSI Development Headquarters  
LSI Business Promotion Group

Contact us for further information about the products.

San Diego +1-858-625-3630  
Atlanta +1-770-754-5972  
Boston +1-978-371-0382  
Chicago +1-847-368-1006  
Dallas +1-972-473-3748  
Denver +1-303-708-0908  
Detroit +1-248-348-9920  
Nashville +1-615-620-6700  
Mexico +52-33-3123-2001  
Düsseldorf +49-2154-9210  
Munich +49-8999-216168  
Stuttgart +49-711-7272-370  
France +33-1-5697-3060

United Kingdom +44-1-908-272400  
Denmark +45-3694-4739  
Espoo +358-9725-54491  
Salu +358-2-7332234  
Oulu +358-8-5372930  
Barcelona +34-9375-24320  
Hungary +36-1-4719338  
Poland +48-22-5757213  
Russia +7-495-739-41-74  
Seoul +82-2-8182-700  
Masan +82-55-240-6234  
Dalian +86-411-8230-8549  
Beijing +86-10-8525-2483

Tianjin +86-22-23029181  
Shanghai +86-21-6279-2727  
Hangzhou +86-571-87658072  
Nanjing +86-25-8689-0015  
Ningbo +86-574-87654201  
Qingdao +86-532-8577-9312  
Suzhou +86-512-6807-1300  
Wuxi +86-510-82702893  
Guangzhou +86-20-3878-8100  
Huizhou +86-752-205-1054  
Fuzhou +86-591-8801-8698  
Dongguan +86-769-8393-3320  
Shenzhen +86-755-8307-3008

Xiamen +86-592-238-5705  
Zhuhai +86-756-3232-480  
Hong Kong +852-2-740-6262  
Taipei +886-2-2500-6956  
Kaohsiung +886-7-237-0881  
Singapore +65-6332-2322  
Philippines +63-2-807-6872  
Thailand +66-2-254-4890  
Kuala Lumpur +60-3-7958-8355  
Penang +60-4-2286453  
Kyoto +81-75-365-1218  
Yokohama +81-45-476-2290

# Notice

## Precaution on using ROHM Products

- Our Products are designed and manufactured for application in ordinary electronic equipments (such as AV equipment, OA equipment, telecommunication equipment, home electronic appliances, amusement equipment, etc.). If you intend to use our Products in devices requiring extremely high reliability (such as medical equipment <sup>(Note 1)</sup>, transport equipment, traffic equipment, aircraft/spacecraft, nuclear power controllers, fuel controllers, car equipment including car accessories, safety devices, etc.) and whose malfunction or failure may cause loss of human life, bodily injury or serious damage to property ("Specific Applications"), please consult with the ROHM sales representative in advance. Unless otherwise agreed in writing by ROHM in advance, ROHM shall not be in any way responsible or liable for any damages, expenses or losses incurred by you or third parties arising from the use of any ROHM's Products for Specific Applications.

(Note1) Medical Equipment Classification of the Specific Applications

JAPAN	USA	EU	CHINA
CLASS III	CLASS III	CLASS II b	CLASS III
CLASS IV		CLASS III	

- ROHM designs and manufactures its Products subject to strict quality control system. However, semiconductor products can fail or malfunction at a certain rate. Please be sure to implement, at your own responsibilities, adequate safety measures including but not limited to fail-safe design against the physical injury, damage to any property, which a failure or malfunction of our Products may cause. The following are examples of safety measures:
  - Installation of protection circuits or other protective devices to improve system safety
  - Installation of redundant circuits to reduce the impact of single or multiple circuit failure
- Our Products are designed and manufactured for use under standard conditions and not under any special or extraordinary environments or conditions, as exemplified below. Accordingly, ROHM shall not be in any way responsible or liable for any damages, expenses or losses arising from the use of any ROHM's Products under any special or extraordinary environments or conditions. If you intend to use our Products under any special or extraordinary environments or conditions (as exemplified below), your independent verification and confirmation of product performance, reliability, etc. prior to use, must be necessary:
  - Use of our Products in any types of liquid, including water, oils, chemicals, and organic solvents
  - Use of our Products outdoors or in places where the Products are exposed to direct sunlight or dust
  - Use of our Products in places where the Products are exposed to sea wind or corrosive gases, including Cl<sub>2</sub>, H<sub>2</sub>S, NH<sub>3</sub>, SO<sub>2</sub>, and NO<sub>2</sub>
  - Use of our Products in places where the Products are exposed to static electricity or electromagnetic waves
  - Use of our Products in proximity to heat-producing components, plastic cords, or other flammable items
  - Sealing or coating our Products with resin or other coating materials
  - Use of our Products without cleaning residue of flux (even if you use no-clean type fluxes, cleaning residue of flux is recommended); or Washing our Products by using water or water-soluble cleaning agents for cleaning residue after soldering
  - Use of the Products in places subject to dew condensation
- The Products are not subject to radiation-proof design.
- Please verify and confirm characteristics of the final or mounted products in using the Products.
- In particular, if a transient load (a large amount of load applied in a short period of time, such as pulse. is applied, confirmation of performance characteristics after on-board mounting is strongly recommended. Avoid applying power exceeding normal rated power; exceeding the power rating under steady-state loading condition may negatively affect product performance and reliability.
- De-rate Power Dissipation (Pd) depending on Ambient temperature (Ta). When used in sealed area, confirm the actual ambient temperature.
- Confirm that operation temperature is within the specified range described in the product specification.
- ROHM shall not be in any way responsible or liable for failure induced under deviant condition from what is defined in this document.

## Precaution for Mounting / Circuit board design

- When a highly active halogenous (chlorine, bromine, etc.) flux is used, the residue of flux may negatively affect product performance and reliability.
- In principle, the reflow soldering method must be used; if flow soldering method is preferred, please consult with the ROHM representative in advance.

For details, please refer to ROHM Mounting specification

**Precautions Regarding Application Examples and External Circuits**

1. If change is made to the constant of an external circuit, please allow a sufficient margin considering variations of the characteristics of the Products and external components, including transient characteristics, as well as static characteristics.
2. You agree that application notes, reference designs, and associated data and information contained in this document are presented only as guidance for Products use. Therefore, in case you use such information, you are solely responsible for it and you must exercise your own independent verification and judgment in the use of such information contained in this document. ROHM shall not be in any way responsible or liable for any damages, expenses or losses incurred by you or third parties arising from the use of such information.

**Precaution for Electrostatic**

This Product is electrostatic sensitive product, which may be damaged due to electrostatic discharge. Please take proper caution in your manufacturing process and storage so that voltage exceeding the Products maximum rating will not be applied to Products. Please take special care under dry condition (e.g. Grounding of human body / equipment / solder iron, isolation from charged objects, setting of Ionizer, friction prevention and temperature / humidity control).

**Precaution for Storage / Transportation**

1. Product performance and soldered connections may deteriorate if the Products are stored in the places where:
  - [a] the Products are exposed to sea winds or corrosive gases, including Cl<sub>2</sub>, H<sub>2</sub>S, NH<sub>3</sub>, SO<sub>2</sub>, and NO<sub>2</sub>
  - [b] the temperature or humidity exceeds those recommended by ROHM
  - [c] the Products are exposed to direct sunshine or condensation
  - [d] the Products are exposed to high Electrostatic
2. Even under ROHM recommended storage condition, solderability of products out of recommended storage time period may be degraded. It is strongly recommended to confirm solderability before using Products of which storage time is exceeding the recommended storage time period.
3. Store / transport cartons in the correct direction, which is indicated on a carton with a symbol. Otherwise bent leads may occur due to excessive stress applied when dropping of a carton.
4. Use Products within the specified time after opening a humidity barrier bag. Baking is required before using Products of which storage time is exceeding the recommended storage time period.

**Precaution for Product Label**

QR code printed on ROHM Products label is for ROHM's internal use only.

**Precaution for Disposition**

When disposing Products please dispose them properly using an authorized industry waste company.

**Precaution for Foreign Exchange and Foreign Trade act**

Since our Products might fall under controlled goods prescribed by the applicable foreign exchange and foreign trade act, please consult with ROHM representative in case of export.

**Precaution Regarding Intellectual Property Rights**

1. All information and data including but not limited to application example contained in this document is for reference only. ROHM does not warrant that foregoing information or data will not infringe any intellectual property rights or any other rights of any third party regarding such information or data. ROHM shall not be in any way responsible or liable for infringement of any intellectual property rights or other damages arising from use of such information or data.:
2. No license, expressly or implied, is granted hereby under any intellectual property rights or other rights of ROHM or any third parties with respect to the information contained in this document.

**Other Precaution**

1. This document may not be reprinted or reproduced, in whole or in part, without prior written consent of ROHM.
2. The Products may not be disassembled, converted, modified, reproduced or otherwise changed without prior written consent of ROHM.
3. In no event shall you use in any way whatsoever the Products and the related technical information contained in the Products or this document for any military purposes, including but not limited to, the development of mass-destruction weapons.
4. The proper names of companies or products described in this document are trademarks or registered trademarks of ROHM, its affiliated companies or third parties.

**General Precaution**

1. Before you use our Products, you are requested to carefully read this document and fully understand its contents. ROHM shall not be in any way responsible or liable for failure, malfunction or accident arising from the use of any ROHM's Products against warning, caution or note contained in this document.
2. All information contained in this document is current as of the issuing date and subject to change without any prior notice. Before purchasing or using ROHM's Products, please confirm the latest information with a ROHM sales representative.
3. The information contained in this document is provided on an "as is" basis and ROHM does not warrant that all information contained in this document is accurate and/or error-free. ROHM shall not be in any way responsible or liable for any damages, expenses or losses incurred by you or third parties resulting from inaccuracy or errors of or concerning such information.

## Looking for pricing, stock, or lifecycle information?

Click below to explore more details on WIN SOURCE:

- [View BD9302FP-E2 on WIN SOURCE](#)
- [Rohm Semiconductor Information](#)

## Optimize Your Supply Chain with WIN SOURCE Solutions

- ✓ Global Sourcing Solution
- ✓ Obsolete Management
- ✓ Cost Control Management
- ✓ Shortage Management
- ✓ Alternative Solution
- ✓ Excess Inventory Management