

4.2V to 18V Input 1ch Boost Controller

BD9306AFVM

General Description

BD9306AFVM is a 1-channel DC/DC converter controller. A Step-up DC/DC converter can be configured. In addition, it has a built-in master-slave function which improves synchronization.

Key Specifications

- Power Supply Voltage Range: 4.2V to 18V
- Error Amplifier Feed Back Voltage: $1.25 \pm 1.6\%$
- Oscillating Frequency Range: 100kHz to 800kHz
- Standby Current: 0 μ A(Typ)
- Operating Temperature Range: -40°C to +85°C

Features

- 1ch PWM Controlled DC/DC Converter Controller
- Built-in Soft Start Function
- Built-in Master / Slave Function
- Protection Circuits:
 - Under Voltage Lockout Protection Circuit
 - Thermal Shutdown Circuit
 - Short Protection Circuit of Timer Latch type

Applications

- TV, Power Supply for the TFT-LCD Panels used for LCD TVs, Back Lights
- DSC, DVC, Printer, DVD ,DVD Recorder, Generally Consumer Equipments etc.

Package

W(Typ) x D(Typ) x H(Max)

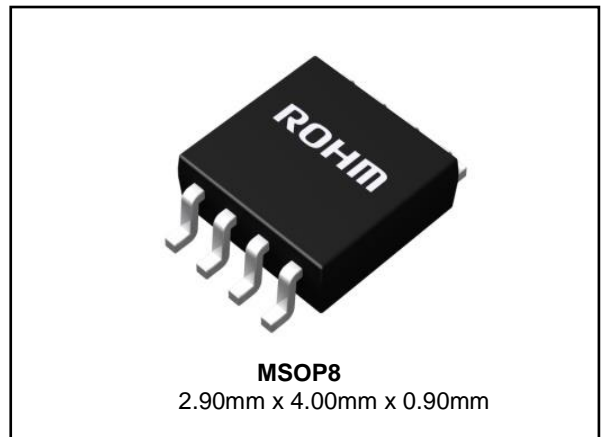

Typical Application Circuit

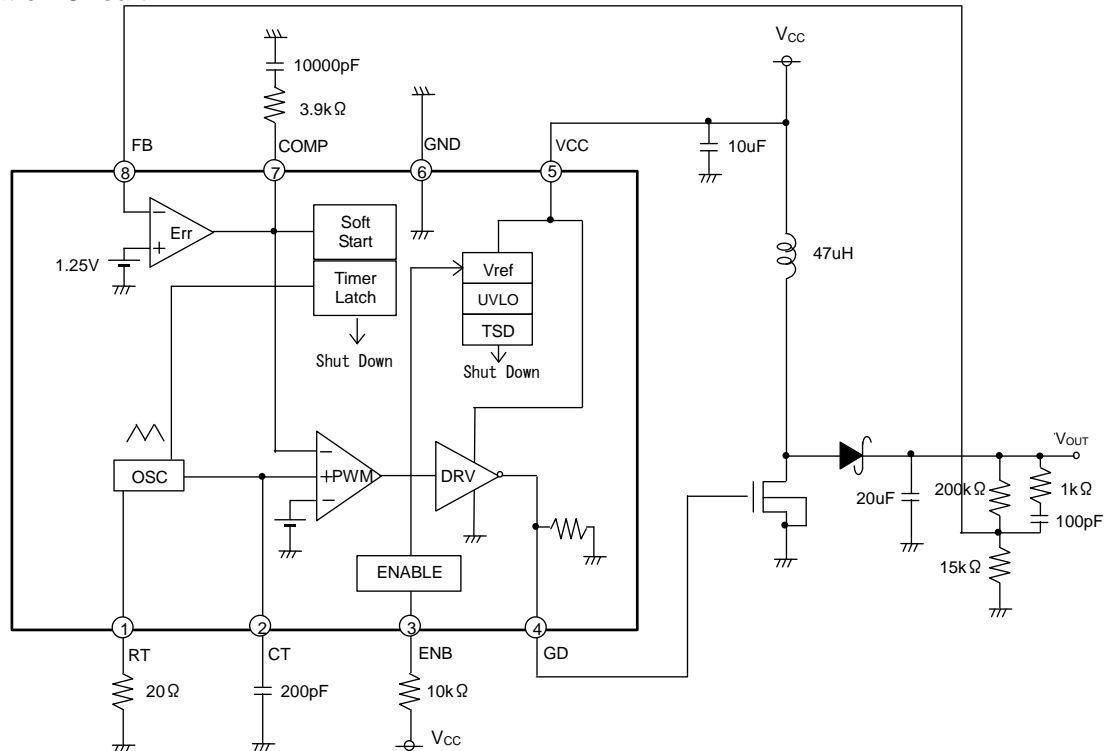
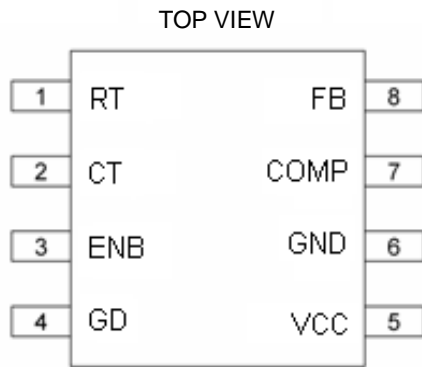

Figure 1. Typical Application Circuit

Pin Configuration



Pin Descriptions

Pin No	Pin Name	Function
1	RT	External timing resistor pin
2	CT	External timing capacitor pin
3	ENB	Control pin
4	GD	Gate drive output pin
5	VCC	Power supply pin
6	GND	Ground pin
7	COMP	Error amp output pin
8	FB	Error amp inversion input pin

Block Diagram

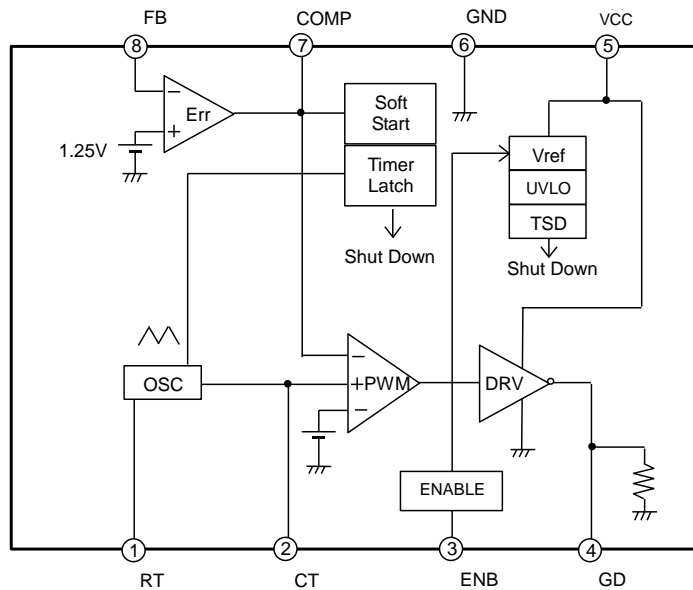

Block Operation

1. Error Amplifier (Err)
It compares a reference voltage of 1.25V (TYP) and the output feedback voltage.
This block produces the COMP terminal voltage that determines the duty cycle.
2. Oscillator (OSC)
This block determines the switching frequency by RT and CT values. The triangular wave is determined by RT and CT.
3. PWM
The duty cycle is determined by comparing the output of Error amplifier and the angular wave of Oscillator.
The switching Duty of BD9306AFVM is limited by the maximum duty ratio that is determined by the internal part, and will not be up to 100%.
4. DRV
This block drives the gate of the external power FET by the PWM switching Duty.
5. VREF
This block outputs the internal reference voltage of 2.5V (TYP).
This circuit's reference voltage is controlled (ON / OFF) by the ENB terminal.
6. Protection Circuits (UVLO / TSD)
UVLO (low-voltage Lock Out circuit) shuts down the circuits when the voltage is below 3.5V (MIN).
TSD (temperature protection circuit) shuts down the IC when the temperature reaches 175°C (TYP).
7. Soft Start Circuit
The Soft Start Circuit limits the current when the output voltage is slowly increasing during start-up.
Through this, the overshoot of output voltage and current sinking can be prevented.
8. Timer Latch
It is an output short protection circuit that detects if the output of error amplifier (COMP voltage) is more than 1.7V (TYP). If the COMP voltage becomes more than 1.7V, the counter begins to operate. The LATCH is locked when the counter counts to 2200 and the GD output shuts down. The frequency of counter is determined by RT and CT.
Once the LATCH was locked, the GD output will not operate until it is restarted by ENB or VCC. If the output short is removed while the Timer latch is counting, the counter will be reset.

Absolute Maximum Ratings (Ta = 25°C)

Parameter	Symbol	Limit	Unit
Power Supply Voltage (Note 2)	V _{CC}	20	V
Power Dissipation	P _d	0.58 (Note 1)	W
Operating Temperature Range	T _{opr}	-40 to +85	°C
Storage Temperature Range	T _{stg}	-55 to +150	°C
Maximum Junction Temperature	T _{jmax}	150	°C

(Note 1) When mounted on a glass epoxy 4-layer board (70 mm x 70 mm x 1.6 mm). Derate by 4.7 mW/°C for Ta over 25°C.

(Note 2) Must not exceed P_d.

Caution: Operating the IC over the absolute maximum ratings may damage the IC. The damage can either be a short circuit between pins or an open circuit between pins. Therefore, it is important to consider circuit protection measures, such as adding a fuse, in case the IC is operated over the absolute maximum ratings.

Recommended Operating Conditions (Ta=-40°C to +85°C)

Parameter	Symbol	Limit			Unit
		Min	Typ	Max	
Power Supply Voltage	V _{CC}	4.2	12	18	V
Control Voltage	V _{ENB}	-	-	V _{CC}	V
Timing Capacitance	C _{CT}	100	-	1000	pF
Timing Resistance	R _{RT}	5	-	50	kΩ
Oscillating Frequency	f _{OSC}	100	-	800	kHz

Electrical Characteristics (Unless otherwise specified Ta=25°C, V_{CC}=12V, C_{CT}=200pF, R_{RT}=20kΩ)

Parameter	Symbol	Limit			Unit	Conditions
		Min	Typ	Max		
【Triangular Waveform Oscillator Block】						
Oscillating Frequency	f _{OSC}	165	220	275	kHz	V _{CC} =5V
Charge Threshold Voltage	V _{OSC+}	0.80	0.85	0.90	V	
Discharge Threshold Voltage	V _{OSC-}	0.20	0.25	0.30	V	
【Under-voltage Lockout Protection Circuit】						
Threshold Voltage	V _{UT}	3.5	-	4.2	V	
【Error Amp Block】						
Feed Back Voltage	V _{FB}	1.230	1.250	1.270	V	
Input Bias Current	I _{IB}	-	0.05	1	μA	V _{FB} =1.5V
COMP Sink Current	I _{OI}	35	50	65	μA	V _{FB} =1.5V V _{COMP} =1.25V
COMP Source Current	I _{OO}	35	50	65	μA	V _{FB} =1.0V V _{COMP} =1.25V
【Gate Drive Block】						
ON-Resistance	R _{ON}	-	5	-	Ω	
Gate Drive Voltage L	V _{GDL}	-	0	0.5	V	No Load
Gate Drive Voltage H	V _{GDLH}	V _{CC} -0.5	V _{CC}	-	V	No Load
MAX Duty	MDT	-	83	-	%	V _{CC} =5V
【Control Block】						
ON Voltage	V _{ON}	2	-	-	V	
OFF Voltage	V _{OFF}	-	-	0.3	V	
ENB Sink Current	I _{ENB}	40	60	90	μA	V _{ENB} =5V
【Soft Start Block】						
Soft Start Time	t _s	-	10	-	ms	
【Timer Latch Protection Circuit】						
Latch Detection COMP Voltage	V _{LC}	1.5	1.7	1.9	V	
Latch Delay OSC Count Number	CNT	-	2200	-	COUNT	
Latch Delay Time	DLY	-	10	-	ms	
【Overall】						
Standby Current	I _{STBY}	-	0	10	μA	ENB=OFF
Average Consumption Current	I _{CC}	1.0	1.5	2.5	mA	No Switching

Typical Performance Curves

(Unless otherwise specified, $V_{CC}=12V$, $T_a=25^{\circ}C$)

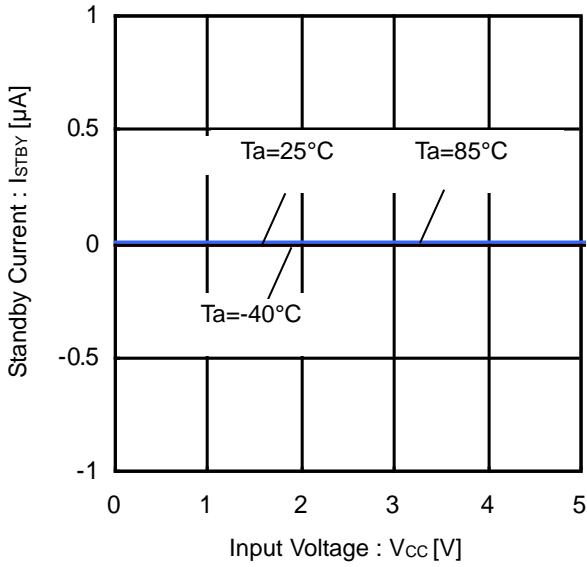

Figure 2. Standby Current vs Input Voltage

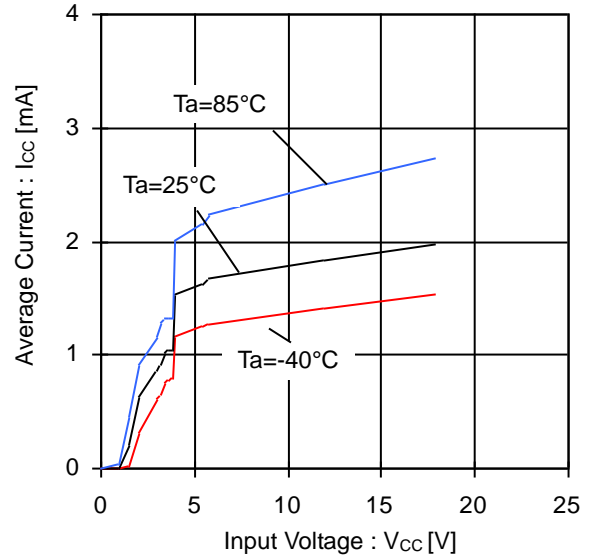

Figure 3. Average Consumption Current vs Input Voltage

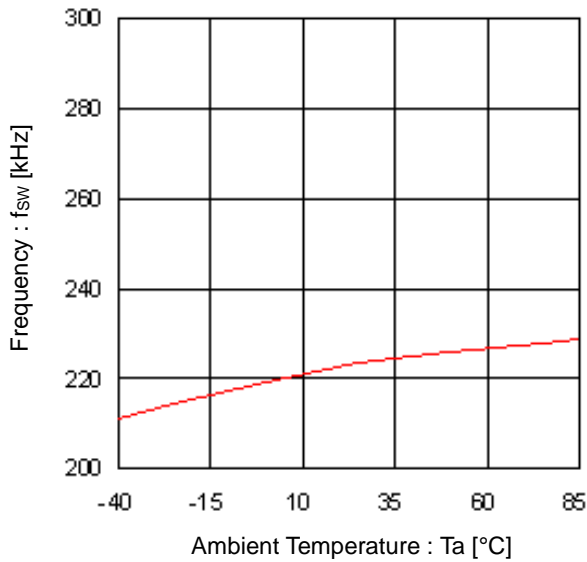

Figure 4. Frequency vs Ambient Temperature

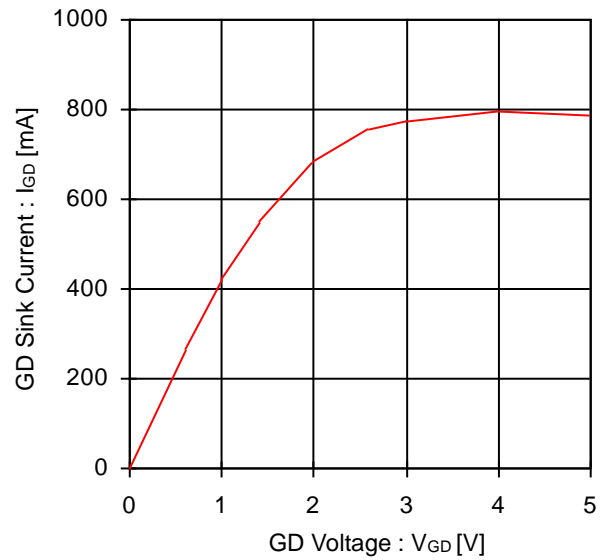

Figure 5. GD Sink Current vs GD Voltage

Typical Performance Curves - continued
 (Unless otherwise specified, $V_{CC}=12V$, $T_a=25^{\circ}C$)

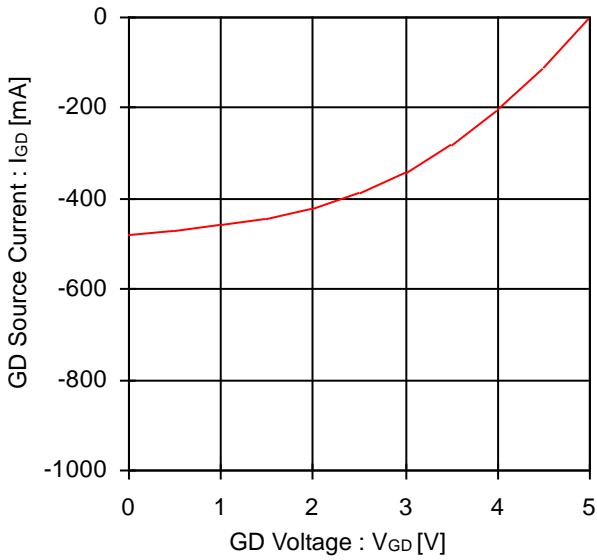

Figure 6. GD Source Current vs GD Voltage

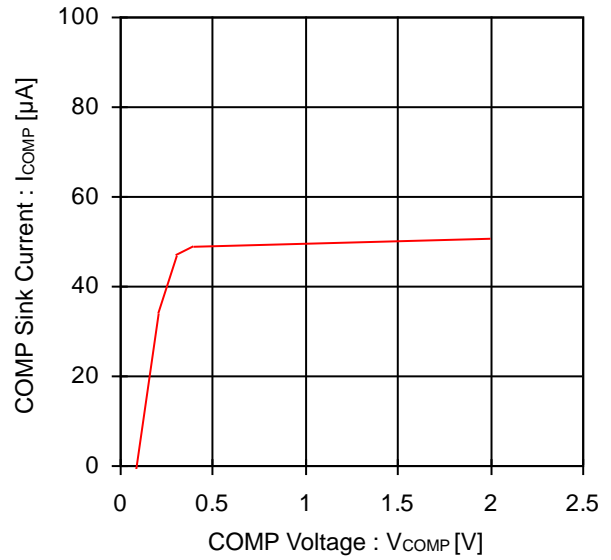

Figure 7. COMP Sink Current vs COMP Voltage

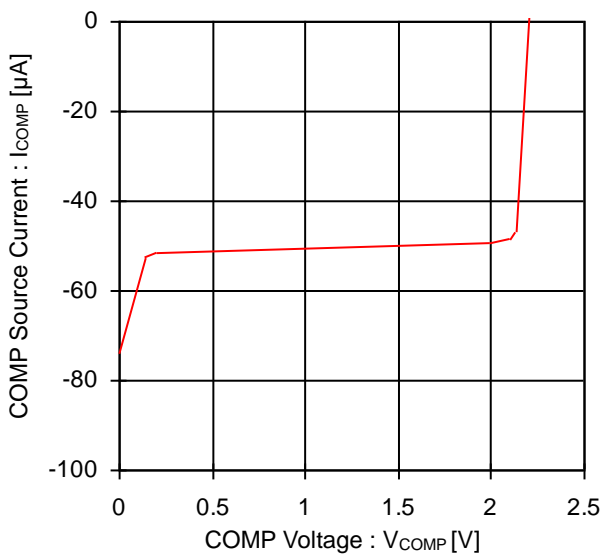

Figure 8. COMP Source Current vs COMP Voltage

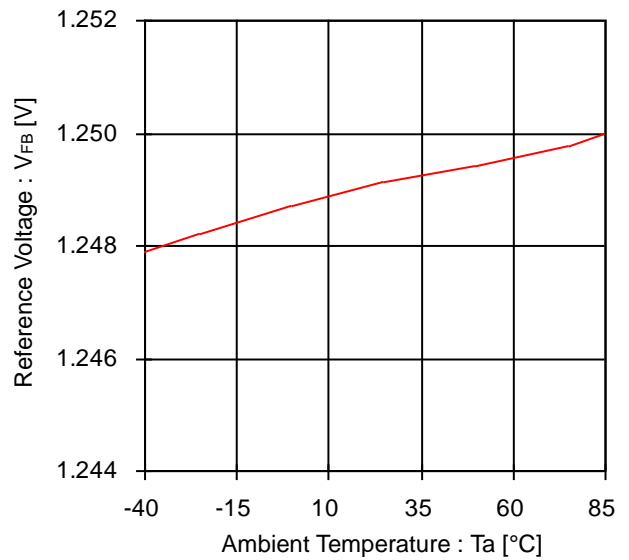

Figure 9. Reference Voltage vs Ambient Temperature

Typical Performance Curves - continued
 (Unless otherwise specified, $V_{CC}=12V$, $T_a=25^{\circ}C$)

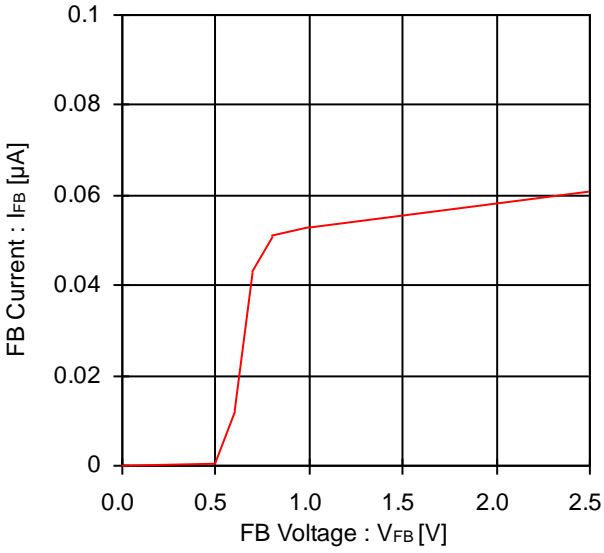

Figure 10. FB Input Bias Current vs FB Voltage

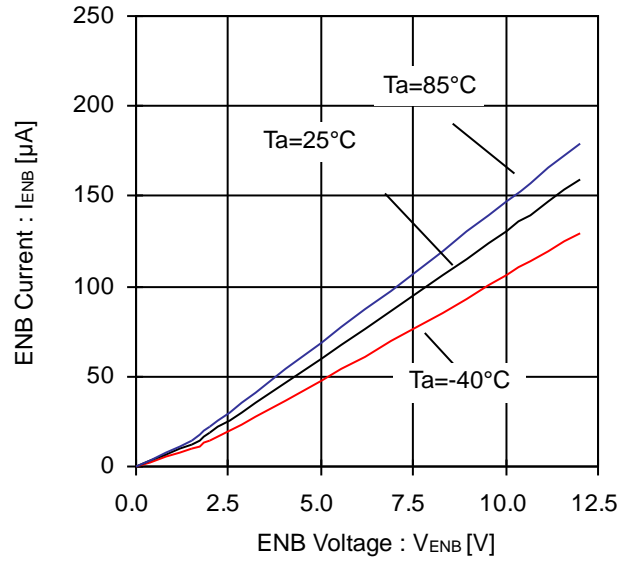

Figure 11. ENB Input Current vs ENB Voltage

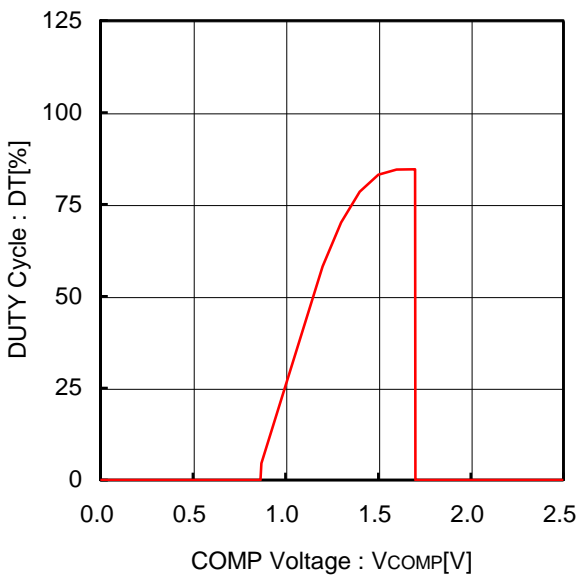

Figure 12. DUTY Cycle vs COMP Voltage

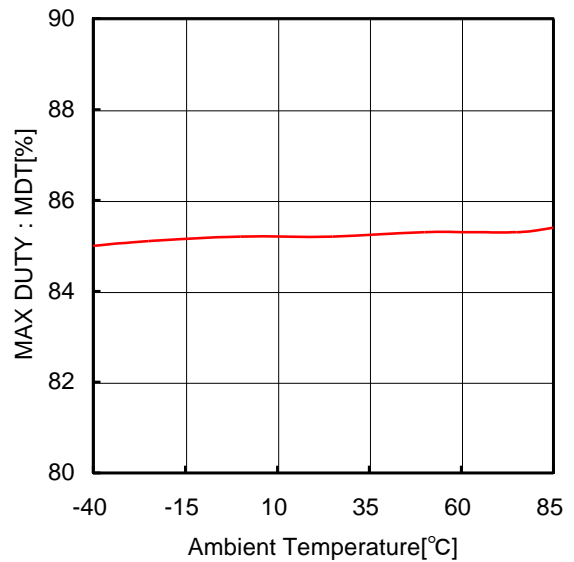

Figure 13. MAX DUTY vs Ambient Temperature

Typical Performance Curves - continued
 (Unless otherwise specified, $V_{CC}=12V$, $T_a=25^{\circ}C$)

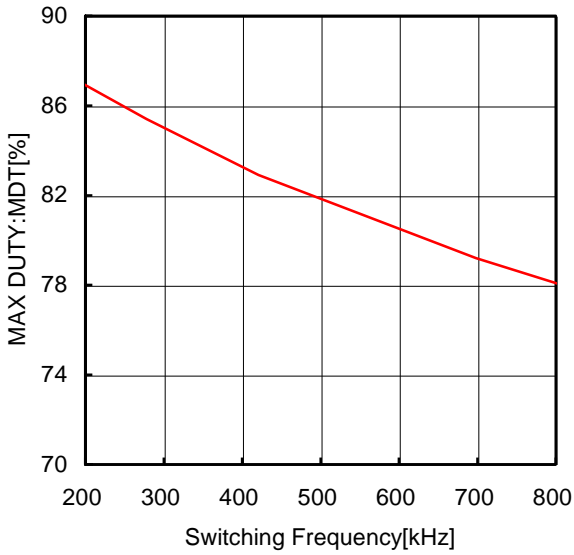

Figure 14. MAX DUTY vs Switching Frequency

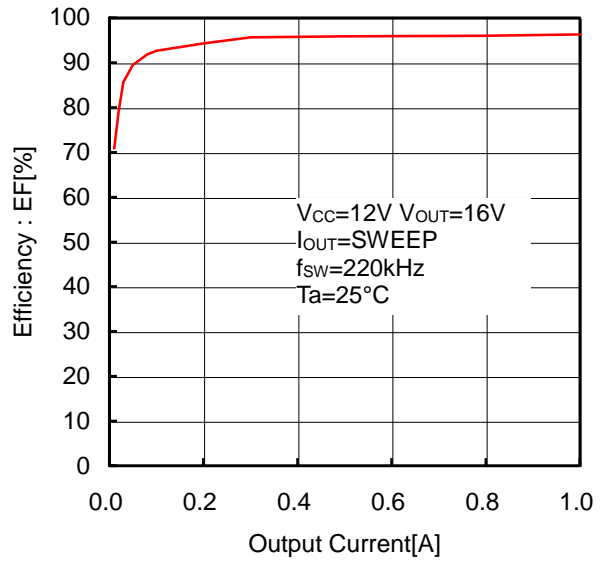

Figure 15. Efficiency vs Output Current

Typical Waveforms

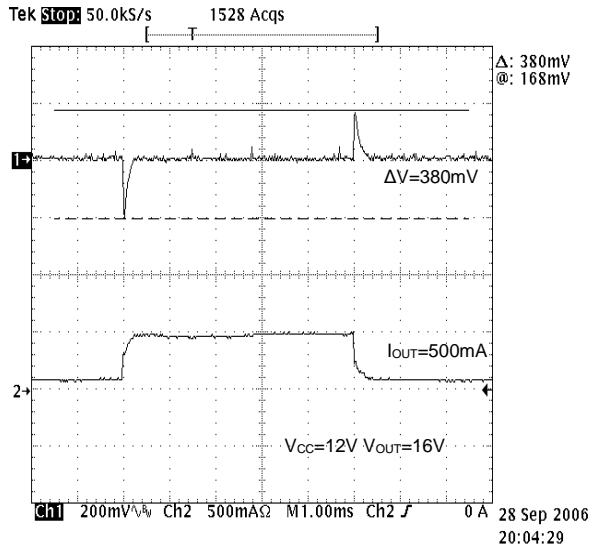

Figure 16. Load Response

Application Information

1. Selecting Application Components

- (1) Setting the Output L Constant (Step Down DC/DC)
The inductance L used for output was decided by the rated current I_{LR} and input current maximum value I_{OMAX} of the inductance.

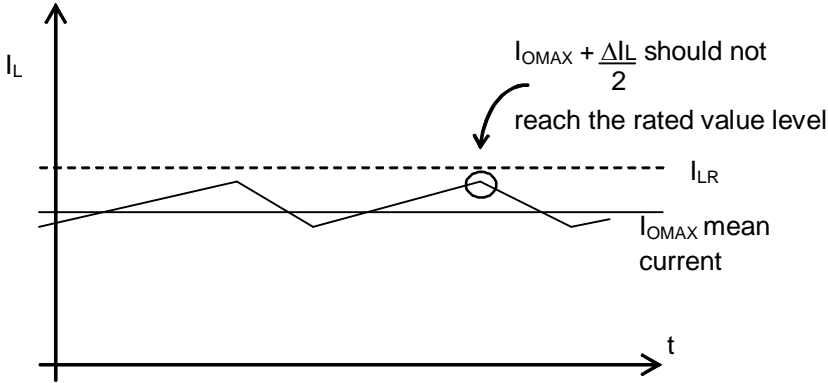

Figure 17. Coil Current Waveform (Step Down DC/DC)

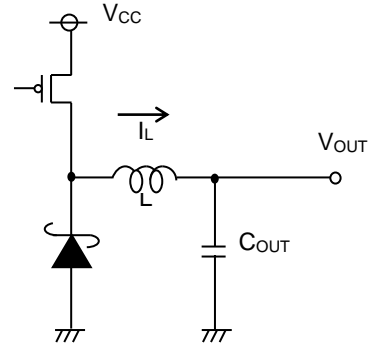

Figure 18. Output Application Circuit (Step Down DC/DC)

Adjust so that $I_{OMAX} + \Delta I_L / 2$ does not reach the rated current value I_{LR} .
At this time, ΔI_L can be obtained by the following equation.

$$\Delta I_L = \frac{1}{L} \times (V_{CC} - V_{OUT}) \times \frac{V_{OUT}}{V_{CC}} \times \frac{1}{f} \quad [A]$$

Set a sufficient margin because the inductance L value may have $\pm 30\%$ dispersion.
If the coil current exceeds the rating current I_{LR} of the coil, it can cause damage to the IC internal elements.

- (2) Setting the Output L Constant (Step Up DC/DC)
The inductance L to use for output is decided by the rated current I_{LR} and input current maximum value I_{INMAX} of the inductance.

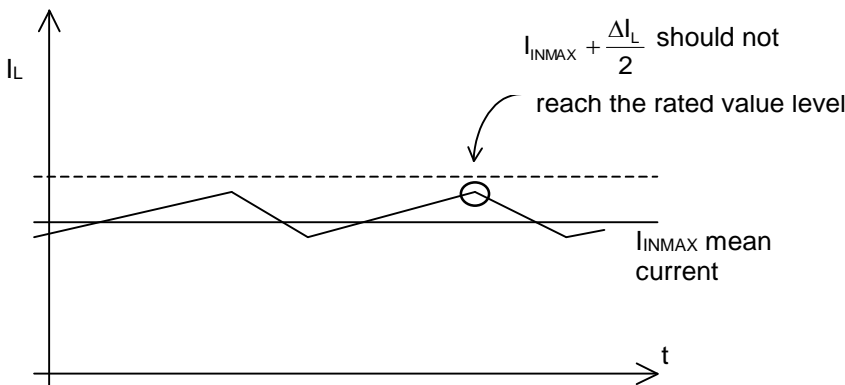

Figure 19. Coil Current Waveform (Step Up DC/DC)

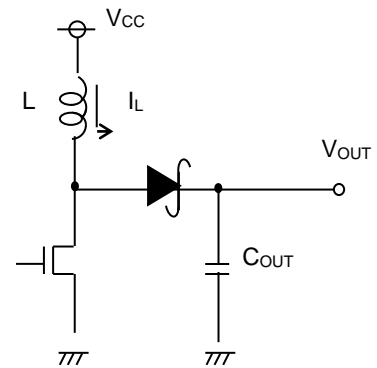

Figure 20. Output Application Circuit (Step Up DC/DC)

Adjust so that $I_{INMAX} + \Delta I_L / 2$ does not reach the rated current value I_{LR} .
At this time, ΔI_L can be obtained by the following equation.

$$\Delta I_L = \frac{1}{L} \times V_{CC} \times \frac{V_{OUT} - V_{CC}}{V_{OUT}} \times \frac{1}{f} \quad [A]$$

where:
 f is the switching frequency

Set a sufficient margin because the inductance L value may have $\pm 30\%$ dispersion.
If the coil current exceeds the rating current I_{LR} of the coil, it can cause damage to the IC internal elements.

(3) Setting the Output Capacitor

For the output capacitor C, select a capacitor which has a larger value at the ripple voltage V_{PP} allowance value and the drop voltage allowance value when there's a sudden load change.

Output ripple voltage is determined by the following equation.

$$\Delta V_{pp} = \Delta I_L \times R_{ESR} + \frac{\Delta I_L}{2C_{OUT}} \times \frac{V_{OUT}}{V_{CC}} \times \frac{1}{f} \quad [V] \quad (\text{Step Down DC/DC})$$

$$\Delta V_{pp} = I_{LMAX} \times R_{ESR} + \frac{1}{fC_{OUT}} \times \frac{V_{CC}}{V_{OUT}} \times \left(I_{LMAX} - \frac{\Delta I_L}{2} \right) \quad [V] \quad (\text{Step Up DC/DC})$$

Apply the setting so that the voltage is within the allowable ripple voltage range.

For the drop voltage during the sudden load change (V_{DR}), perform a rough calculation by the following equation.

$$V_{DR} = \frac{\Delta I}{C_{OUT}} \times 10\mu\text{sec} \quad [V]$$

However, 10 μs is the rough calculation value of the DC/DC response speed. Set the capacitance while considering a sufficient margin so that these two values are within the standard value range.

(4) Setting of Feedback Resistance Constant

Refer to the following formula for setting of feedback resistance.

$$V_{OUT} = \frac{R_1 + R_2}{R_2} \times 1.25 \quad [V]$$

It is recommend to use 10k Ω to 330k Ω setting range. If a resistance below 10k Ω was set, voltage efficiency will be dropped. If a resistance of more than 330k Ω was set, the offset voltage becomes large because of the internal error amplifier's input bias current of 0.05 μA (Typ). Please set the maximum setting voltage of BD9306AFVM (step up) in such a way that Duty : $(V_{OUT} - V_{CC}) / V_{OUT}$ is less than 70%.

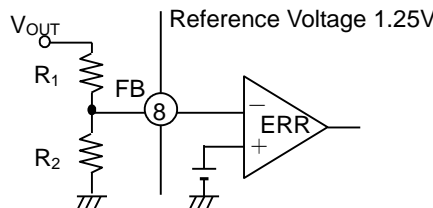

Figure 21. Feedback Resistance Setting

(5) Setting of Oscillating Frequency

The angular wave oscillation frequency can be set by connecting a resistor and a capacitor to RT (Pin 1) and CT (Pin 2) respectively. The charge and discharge currents at the capacitor of CT will be determined by the RT resistor.

Refer to the configuration below for setting the RT's resistor and the CT's capacitor.

R_{RT} : 5k Ω to 50k Ω , C_{CT} : 100pF to 1000pF. The frequency range of 100kHz to 800kHz are recommended.

Remember that the switching will stop if your setting is off this range.

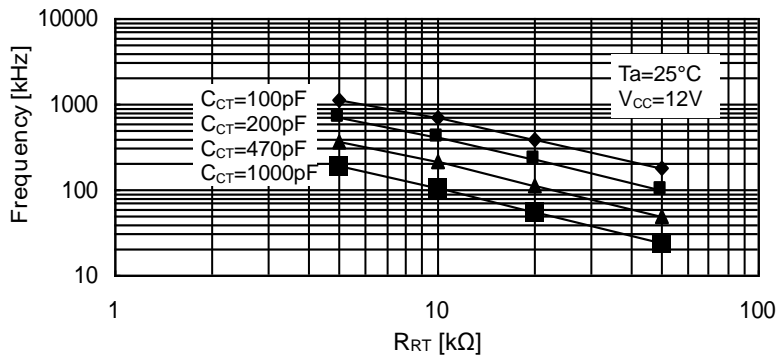

Figure 22. Frequency Setting

(6) Selection of Input Capacitor

For DC/DC converter, the capacitor at the input side is also necessary because maximum current will be flowing between input and output. Therefore, it is recommended that an input capacitor with over 10 μ F and low ESR below 100m Ω . If a selected capacitor is outside this range, excessive large ripple voltage will overlap with the input voltage which may cause IC malfunction. However, this condition varies with negative overcurrent, input voltage, output voltage, inductor's value, and switching frequency so make sure to have a margin check with actual devices.

(7) Selection of Output Rectifier Diode

Schottky barrier diode is recommended as the diode for rectification at the output stage of DC/DC converter. Refer below for choosing the maximum inductor current, the maximum output voltage, and the power supply voltage.

<step-down DC/DC>

Maximum inductor current	$I_{OMAX} + \frac{\Delta I_L}{2}$	<	Diode's rated current
--------------------------	-----------------------------------	---	-----------------------

Power supply voltage	V_{CC}	<	Diode's rated voltage
----------------------	----------	---	-----------------------

<step-up DC/DC>

Maximum inductor current	$I_{INMAX} + \frac{\Delta I_L}{2}$	<	Diode's rated current
--------------------------	------------------------------------	---	-----------------------

Maximum output voltage	V_{OMAX}	<	Diode's rated voltage
------------------------	------------	---	-----------------------

Furthermore, each parameter has a deviation of 30% to 40%, so design in such a way that you have provided enough margin for the deviation in your design.

(8) Setting of Power FET

If step-up DC/DC is configured by BD9306AFVM, Nch FET is necessary.

Consider the following conditions when you choose:

<step-down DC/DC>

Maximum inductor current	$I_{OMAX} + \frac{\Delta I_L}{2}$	<	FET's rated current
--------------------------	-----------------------------------	---	---------------------

Power supply voltage	V_{CC}	<	FET's rated voltage
----------------------	----------	---	---------------------

Power supply voltage	V_{CC}	>	FET's gate ON voltage
----------------------	----------	---	-----------------------

Gate capacitance (Note 1)	C_{GATE}	<	2000pF
---------------------------	------------	---	--------

<step-up DC/DC>

Maximum inductor current	$I_{INMAX} + \frac{\Delta I_L}{2}$	<	FET's rated current
--------------------------	------------------------------------	---	---------------------

Maximum output voltage	V_{OMAX}	<	FET's rated voltage
------------------------	------------	---	---------------------

Power supply voltage	V_{CC}	>	FET's gate ON voltage
----------------------	----------	---	-----------------------

Gate capacitance (Note 1)	C_{GATE}	<	2000pF
---------------------------	------------	---	--------

Furthermore, each parameter has a deviation of 30% to 40%, so design in such a way that you have provided enough margin for the deviation in your design.

(Note 1) If the Gate capacity becomes large, the switching speed will be slower, which may cause heat generation and breakdown, so check thoroughly the actual devices.

(9) Phase Compensation
Phase Setting Method

The following conditions are required to ensure the stability of the negative feedback circuit.

Phase lag should be 150° or lower when gain is 1 (0 dB) (phase margin of 30° or higher).

Because DC/DC converter applications are sampled using the switching frequency, the overall GBW should be set to 1/10 the switching frequency or lower. The target application characteristics can be summarized as follows:

- Phase lag should be 150° or lower when gain is 1 (0 dB) (phase margin of 30° or higher).
- The GBW at that time (i.e., the frequency of a 0-dB gain) is 1/10 of the switching frequency or below.

In other words, because the response is limited by the GBW, it is necessary to use higher switching frequencies to raise response.

One way to maintain stability through phase compensation involves cancellation of the secondary phase lag (-180°) caused by LC resonance with a secondary phase advance (by inserting 2 phase advances). The GBW (i.e., the frequency with the gain set to 1) is determined by the phase compensation capacitor connected to the error amp. Increase the capacitance if a GBW reduction is required.

(a) Standard integrator (low-pass filter)

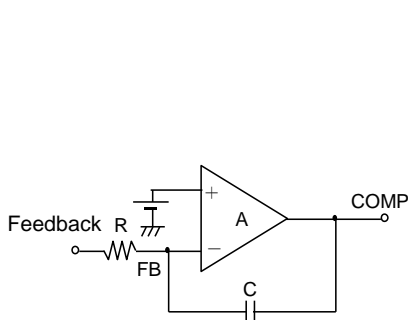

Figure 23

(b) Open loop characteristics of integrator

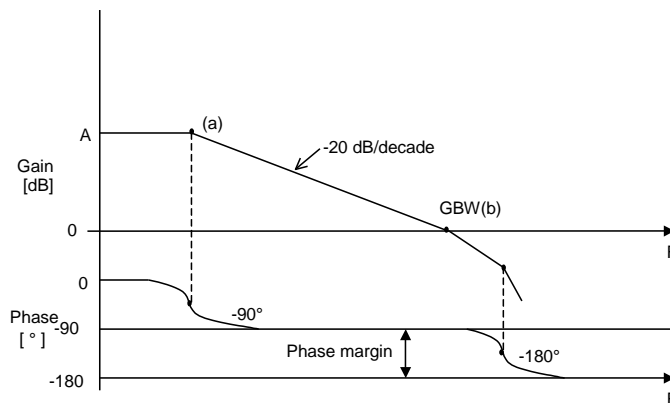

Figure 24

Point (a) $f_a = \frac{1}{2\pi R C A}$ [Hz]

Point (b) $f_b = GBW = \frac{1}{2\pi R C}$ [Hz]

The error amp performs the phase compensation at points (a) and (b) and it acts as a low-pass filter. For DC/DC converter applications, R refers to feedback resistors connected in parallel. From the LC resonance of output, the number of phase advances to be inserted is two.

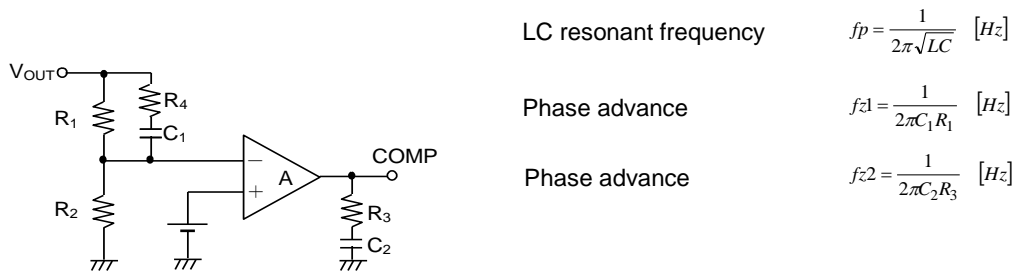

Figure 25

Set a phase advance frequency close to the LC resonant frequency for the purpose of canceling the LC resonance.

(Note) If high-frequency noise is generated in the output, FB is affected through capacitor C₁. Therefore, insert the resistor R₄=1kΩ or so, which is in series with capacitor C₁.

2.Example of Application

(Note) We strongly recommend the following application circuit examples but check thoroughly the characteristics before putting using them.

When you made changes at the external circuit, design a sufficient margin after considering the deviation, etc. of the external components and ROHM IC in terms of not only the static characteristic but also the transient characteristic. Moreover, understand that our company can not confirm fully with regard to the patent right.

<Master Slave Function>

The master slave function is built-in. Synchronous switching is possible by the multi-connection of BD9305AFVM/BD9306AFVM ICs. The following drawing shows an example of circuit connection in which BD9305AFVM is connected on the master side and BD9306AFVM is connected on the slave side.

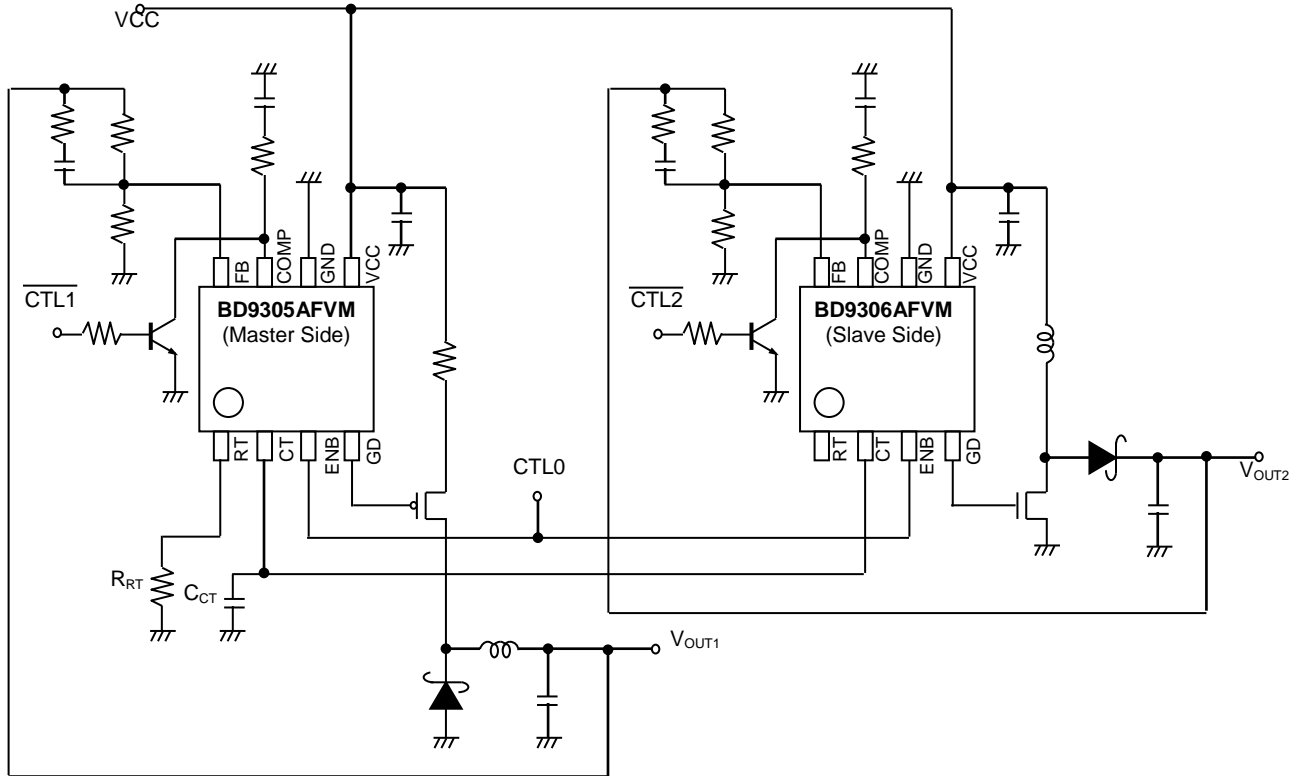

Figure 26. Master Slave Application Circuit

In the circuit above, BD9306AFVM is synchronized with the switching frequency which is determined by RT and CT of BD9305AFVM (master). In addition, the ON/OFF of output can be controlled by connecting the switch to the COMP terminal. (Refer to the following table)

Control signal correspondence table

Output state		Control signal		
V _{OUT1}	V _{OUT2}	CTL0	CTL1	CTL2
OFF	OFF	Low	(Note)	(Note)
OFF	ON	High	High	Low
ON	OFF	High	Low	High
ON	ON	High	Low	Low

(Note) The same in either case of High / Low.

Similarly in the case of connecting three or more than three, synchronization is still possible by connecting the CT terminal of Master and the CT terminal of Slave.

I/O Equivalent Circuits

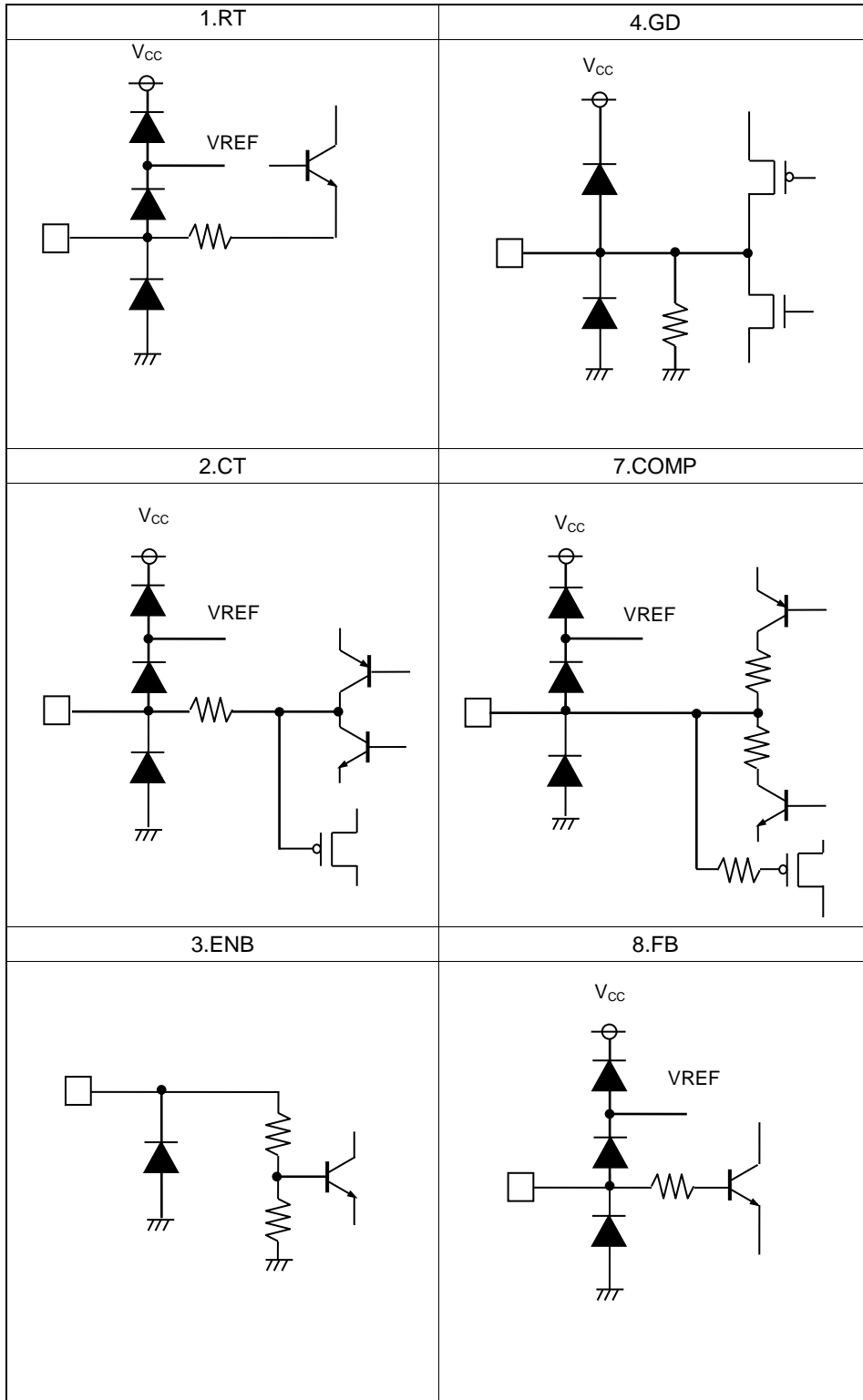

Operational Notes

- 1. Reverse Connection of Power Supply**

Connecting the power supply in reverse polarity can damage the IC. Take precautions against reverse polarity when connecting the power supply, such as mounting an external diode between the power supply and the IC's power supply pins.
- 2. Power Supply Lines**

Design the PCB layout pattern to provide low impedance supply lines. Separate the ground and supply lines of the digital and analog blocks to prevent noise in the ground and supply lines of the digital block from affecting the analog block. Furthermore, connect a capacitor to ground at all power supply pins. Consider the effect of temperature and aging on the capacitance value when using electrolytic capacitors.
- 3. Ground Voltage**

Ensure that no pins are at a voltage below that of the ground pin at any time, even during transient condition.
- 4. Ground Wiring Pattern**

When using both small-signal and large-current ground traces, the two ground traces should be routed separately but connected to a single ground at the reference point of the application board to avoid fluctuations in the small-signal ground caused by large currents. Also ensure that the ground traces of external components do not cause variations on the ground voltage. The ground lines must be as short and thick as possible to reduce line impedance.
- 5. Thermal Consideration**

Should by any chance the maximum junction temperature rating be exceeded the rise in temperature of the chip may result in deterioration of the properties of the chip. In case of exceeding this absolute maximum rating, increase the board size and copper area to prevent exceeding the maximum junction temperature rating.
- 6. Recommended Operating Conditions**

These conditions represent a range within which the expected characteristics of the IC can be approximately obtained. The electrical characteristics are guaranteed under the conditions of each parameter.
- 7. Inrush Current**

When power is first supplied to the IC, it is possible that the internal logic may be unstable and inrush current may flow instantaneously due to the internal powering sequence and delays, especially if the IC has more than one power supply. Therefore, give special consideration to power coupling capacitance, power wiring, width of ground wiring, and routing of connections.
- 8. Operation Under Strong Electromagnetic Field**

Operating the IC in the presence of a strong electromagnetic field may cause the IC to malfunction.
- 9. Testing on Application Boards**

When testing the IC on an application board, connecting a capacitor directly to a low-impedance output pin may subject the IC to stress. Always discharge capacitors completely after each process or step. The IC's power supply should always be turned off completely before connecting or removing it from the test setup during the inspection process. To prevent damage from static discharge, ground the IC during assembly and use similar precautions during transport and storage.
- 10. Inter-pin Short and Mounting Errors**

Ensure that the direction and position are correct when mounting the IC on the PCB. Incorrect mounting may result in damaging the IC. Avoid nearby pins being shorted to each other especially to ground, power supply and output pin. Inter-pin shorts could be due to many reasons such as metal particles, water droplets (in very humid environment) and unintentional solder bridge deposited in between pins during assembly to name a few.
- 11. Unused Input Pins**

Input pins of an IC are often connected to the gate of a MOS transistor. The gate has extremely high impedance and extremely low capacitance. If left unconnected, the electric field from the outside can easily charge it. The small charge acquired in this way is enough to produce a significant effect on the conduction through the transistor and cause unexpected operation of the IC. So unless otherwise specified, unused input pins should be connected to the power supply or ground line.

Operational Notes – continued

12. Regarding the Input Pin of the IC

This monolithic IC contains P+ isolation and P substrate layers between adjacent elements in order to keep them isolated. P-N junctions are formed at the intersection of the P layers with the N layers of other elements, creating a parasitic diode or transistor. For example (refer to figure below):

When $GND > Pin A$ and $GND > Pin B$, the P-N junction operates as a parasitic diode.

When $GND > Pin B$, the P-N junction operates as a parasitic transistor.

Parasitic diodes inevitably occur in the structure of the IC. The operation of parasitic diodes can result in mutual interference among circuits, operational faults, or physical damage. Therefore, conditions that cause these diodes to operate, such as applying a voltage lower than the GND voltage to an input pin (and thus to the P substrate) should be avoided.

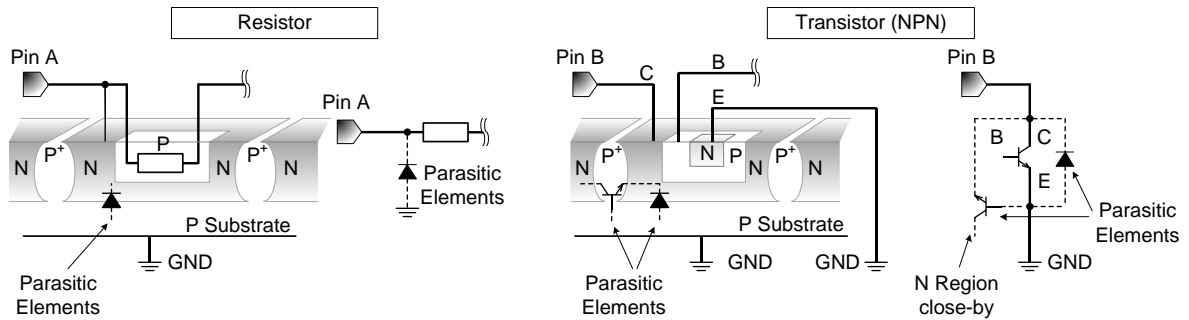

Figure 27. Example of monolithic IC structure

13. Thermal Shutdown Circuit(TSD)

This IC has a built-in thermal shutdown circuit that prevents heat damage to the IC. Normal operation should always be within the IC's power dissipation rating. If however the rating is exceeded for a continued period, the junction temperature (T_j) will rise which will activate the TSD circuit that will turn OFF all output pins. When the T_j falls below the TSD threshold, the circuits are automatically restored to normal operation.

Note that the TSD circuit operates in a situation that exceeds the absolute maximum ratings and therefore, under no circumstances, should the TSD circuit be used in a set design or for any purpose other than protecting the IC from heat damage.

Ordering Information

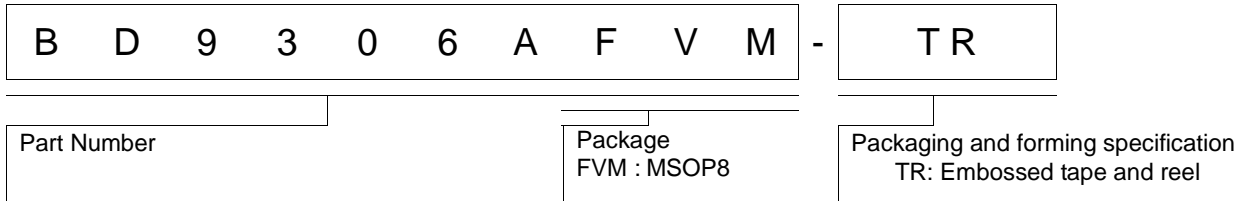

Marking Diagram

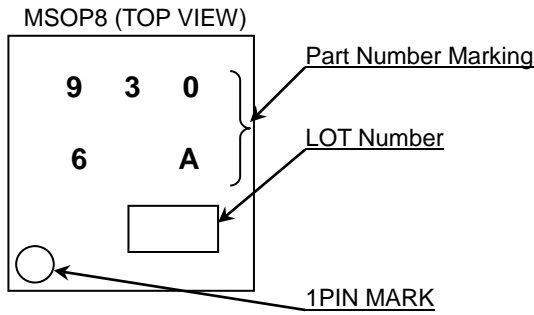

Physical Dimension, Tape and Reel Information

Package Name	MSOP8
--------------	-------

2.9±0.1
Max 3.25 (include BURR)

4.0±0.2
2.8±0.1

0.475

1 PIN MARK

4°±6°
-4°

0.29±0.15
0.6±0.2

0.145^{+0.05}_{-0.03}

0.9 MAX

0.75±0.05
0.08±0.05

0.65

0.22^{+0.05}_{-0.04}

0.08 S

(UNIT : mm)
PKG : MSOP8
Drawing No. EX181-5002

<Tape and Reel information>	
Tape	Embossed carrier tape
Quantity	3000pcs
Direction of feed	TR (The direction is the 1pin of product is at the upper right when you hold reel on the left hand and you pull out the tape on the right hand)

1pin

Direction of feed

Reel

*Order quantity needs to be multiple of the minimum quantity.

Revision History

Date	Revision	Changes
13.Nov.2015	001	New Release

Notice

Precaution on using ROHM Products

- Our Products are designed and manufactured for application in ordinary electronic equipments (such as AV equipment, OA equipment, telecommunication equipment, home electronic appliances, amusement equipment, etc.). If you intend to use our Products in devices requiring extremely high reliability (such as medical equipment ^(Note 1), transport equipment, traffic equipment, aircraft/spacecraft, nuclear power controllers, fuel controllers, car equipment including car accessories, safety devices, etc.) and whose malfunction or failure may cause loss of human life, bodily injury or serious damage to property ("Specific Applications"), please consult with the ROHM sales representative in advance. Unless otherwise agreed in writing by ROHM in advance, ROHM shall not be in any way responsible or liable for any damages, expenses or losses incurred by you or third parties arising from the use of any ROHM's Products for Specific Applications.

(Note1) Medical Equipment Classification of the Specific Applications

JAPAN	USA	EU	CHINA
CLASS III	CLASS III	CLASS II b	CLASS III
CLASS IV		CLASS III	

- ROHM designs and manufactures its Products subject to strict quality control system. However, semiconductor products can fail or malfunction at a certain rate. Please be sure to implement, at your own responsibilities, adequate safety measures including but not limited to fail-safe design against the physical injury, damage to any property, which a failure or malfunction of our Products may cause. The following are examples of safety measures:
 - Installation of protection circuits or other protective devices to improve system safety
 - Installation of redundant circuits to reduce the impact of single or multiple circuit failure
- Our Products are designed and manufactured for use under standard conditions and not under any special or extraordinary environments or conditions, as exemplified below. Accordingly, ROHM shall not be in any way responsible or liable for any damages, expenses or losses arising from the use of any ROHM's Products under any special or extraordinary environments or conditions. If you intend to use our Products under any special or extraordinary environments or conditions (as exemplified below), your independent verification and confirmation of product performance, reliability, etc. prior to use, must be necessary:
 - Use of our Products in any types of liquid, including water, oils, chemicals, and organic solvents
 - Use of our Products outdoors or in places where the Products are exposed to direct sunlight or dust
 - Use of our Products in places where the Products are exposed to sea wind or corrosive gases, including Cl₂, H₂S, NH₃, SO₂, and NO₂
 - Use of our Products in places where the Products are exposed to static electricity or electromagnetic waves
 - Use of our Products in proximity to heat-producing components, plastic cords, or other flammable items
 - Sealing or coating our Products with resin or other coating materials
 - Use of our Products without cleaning residue of flux (even if you use no-clean type fluxes, cleaning residue of flux is recommended); or Washing our Products by using water or water-soluble cleaning agents for cleaning residue after soldering
 - Use of the Products in places subject to dew condensation
- The Products are not subject to radiation-proof design.
- Please verify and confirm characteristics of the final or mounted products in using the Products.
- In particular, if a transient load (a large amount of load applied in a short period of time, such as pulse. is applied, confirmation of performance characteristics after on-board mounting is strongly recommended. Avoid applying power exceeding normal rated power; exceeding the power rating under steady-state loading condition may negatively affect product performance and reliability.
- De-rate Power Dissipation depending on ambient temperature. When used in sealed area, confirm that it is the use in the range that does not exceed the maximum junction temperature.
- Confirm that operation temperature is within the specified range described in the product specification.
- ROHM shall not be in any way responsible or liable for failure induced under deviant condition from what is defined in this document.

Precaution for Mounting / Circuit board design

- When a highly active halogenous (chlorine, bromine, etc.) flux is used, the residue of flux may negatively affect product performance and reliability.
- In principle, the reflow soldering method must be used on a surface-mount products, the flow soldering method must be used on a through hole mount products. If the flow soldering method is preferred on a surface-mount products, please consult with the ROHM representative in advance.

For details, please refer to ROHM Mounting specification

Precautions Regarding Application Examples and External Circuits

1. If change is made to the constant of an external circuit, please allow a sufficient margin considering variations of the characteristics of the Products and external components, including transient characteristics, as well as static characteristics.
2. You agree that application notes, reference designs, and associated data and information contained in this document are presented only as guidance for Products use. Therefore, in case you use such information, you are solely responsible for it and you must exercise your own independent verification and judgment in the use of such information contained in this document. ROHM shall not be in any way responsible or liable for any damages, expenses or losses incurred by you or third parties arising from the use of such information.

Precaution for Electrostatic

This Product is electrostatic sensitive product, which may be damaged due to electrostatic discharge. Please take proper caution in your manufacturing process and storage so that voltage exceeding the Products maximum rating will not be applied to Products. Please take special care under dry condition (e.g. Grounding of human body / equipment / solder iron, isolation from charged objects, setting of Ionizer, friction prevention and temperature / humidity control).

Precaution for Storage / Transportation

1. Product performance and soldered connections may deteriorate if the Products are stored in the places where:
 - [a] the Products are exposed to sea winds or corrosive gases, including Cl₂, H₂S, NH₃, SO₂, and NO₂
 - [b] the temperature or humidity exceeds those recommended by ROHM
 - [c] the Products are exposed to direct sunshine or condensation
 - [d] the Products are exposed to high Electrostatic
2. Even under ROHM recommended storage condition, solderability of products out of recommended storage time period may be degraded. It is strongly recommended to confirm solderability before using Products of which storage time is exceeding the recommended storage time period.
3. Store / transport cartons in the correct direction, which is indicated on a carton with a symbol. Otherwise bent leads may occur due to excessive stress applied when dropping of a carton.
4. Use Products within the specified time after opening a humidity barrier bag. Baking is required before using Products of which storage time is exceeding the recommended storage time period.

Precaution for Product Label

QR code printed on ROHM Products label is for ROHM's internal use only.

Precaution for Disposition

When disposing Products please dispose them properly using an authorized industry waste company.

Precaution for Foreign Exchange and Foreign Trade act

Since concerned goods might be fallen under listed items of export control prescribed by Foreign exchange and Foreign trade act, please consult with ROHM in case of export.

Precaution Regarding Intellectual Property Rights

1. All information and data including but not limited to application example contained in this document is for reference only. ROHM does not warrant that foregoing information or data will not infringe any intellectual property rights or any other rights of any third party regarding such information or data.
2. ROHM shall not have any obligations where the claims, actions or demands arising from the combination of the Products with other articles such as components, circuits, systems or external equipment (including software).
3. No license, expressly or implied, is granted hereby under any intellectual property rights or other rights of ROHM or any third parties with respect to the Products or the information contained in this document. Provided, however, that ROHM will not assert its intellectual property rights or other rights against you or your customers to the extent necessary to manufacture or sell products containing the Products, subject to the terms and conditions herein.

Other Precaution



1. This document may not be reprinted or reproduced, in whole or in part, without prior written consent of ROHM.
2. The Products may not be disassembled, converted, modified, reproduced or otherwise changed without prior written consent of ROHM.
3. In no event shall you use in any way whatsoever the Products and the related technical information contained in the Products or this document for any military purposes, including but not limited to, the development of mass-destruction weapons.
4. The proper names of companies or products described in this document are trademarks or registered trademarks of ROHM, its affiliated companies or third parties.

General Precaution





1. Before you use our Products, you are requested to carefully read this document and fully understand its contents. ROHM shall not be in any way responsible or liable for failure, malfunction or accident arising from the use of any ROHM's Products against warning, caution or note contained in this document.
2. All information contained in this document is current as of the issuing date and subject to change without any prior notice. Before purchasing or using ROHM's Products, please confirm the latest information with a ROHM sales representative.
3. The information contained in this document is provided on an "as is" basis and ROHM does not warrant that all information contained in this document is accurate and/or error-free. ROHM shall not be in any way responsible or liable for any damages, expenses or losses incurred by you or third parties resulting from inaccuracy or errors of or concerning such information.

Looking for pricing, stock, or lifecycle information?

Click below to explore more details on WIN SOURCE:

-  [View BD9306AFVM-TR on WIN SOURCE](#)
-  [Rohm Semiconductor](#) Information

Optimize Your Supply Chain with WIN SOURCE Solutions

-  Global Sourcing Solution
-  Obsolete Management
-  Cost Control Management
-  Shortage Management
-  Alternative Solution
-  Excess Inventory Management