

High-performance Regulator IC Series for PCs



Switching Regulators for DDR-SDRAM Cores

BD9533EKN

•Description

BD9533EKN is a switching regulator controller with high output current which can achieve low output voltage (0.7V to 2.0V) from a wide input voltage range (4.5V to 28V). High efficiency for the switching regulator can be realized by utilizing an external N-MOSFET power transistor. A new technology called H³RegTM is a Rohm proprietary control method to realize ultra high transient response against load change. SLLM (Simple Light Load Mode) technology is also integrated to improve efficiency in light load mode, providing high efficiency over a wide load range. For protection and ease of use, the soft start function, variable frequency function, short circuit protection function with timer latch, over voltage protection function and REF synchronous function are all built in. This switching regulator is specially designed for the DDR-SDRAM core.

•Features

- 1) H³RegTM Switching Regulator Controller
- 2) Light Load Mode and Continuous Mode Changeable
- 3) Thermal Shut Down (TSD), Under Voltage LockOut (UVLO), Over Current Protection (OCP), Over Voltage Protection (OVP), Short Circuit Protection (SCP) built-in
- 4) Soft start function to minimize rush current during startup
- 5) Switching Frequency Variable (f=200KHz~600KHz)
- 6) HQFN20V Package

•Applications

Laptop PC, Desktop PC, LCD-TV, Digital Components

●Maximum Absolute Ratings (Ta=25°C)

Parameter	Symbol	Limit	Unit
Input Voltage 1	VCC	7 ⁻¹	V
Input Voltage 2	VDD	7 ⁻¹	V
Input Voltage 3	VIN	30 ⁻¹	V
BOOT Voltage	BOOT	35 ⁻¹	V
BOOT-SW Voltage	BOOT-SW	7 ⁻¹	V
HG-SW Voltage	HG-SW	7 ⁻¹	V
LG Voltage	LG	VDD	V
REF Voltage	REF	VCC	V
Output Voltage	VOUT/Is+/Is-	VCC	V
ILIM/SCP/SS/FS/SLLM Voltage	ILIM/SCP/SS/FS/SLLM	VCC	V
VREG Voltage	VREG	VCC	V
EN Input Voltage	EN	7 ⁻¹	V
Power Dissipation 1	Pd1	0.5 ⁻²	W
Power Dissipation 2	Pd2	0.75 ⁻³	W
Power Dissipation 3	Pd3	1.75 ⁻⁴	W
Power Dissipation 4	Pd4	2.00 ⁻⁵	W
Operating Temperature Range	Topr	-10~+100	°C
Storage Temperature Range	Tstg	-55~+150	°C
Maximum Junction Temperature	Tjmax	+150	°C

*1 Not to exceed Pd.

*2 Reduced by 4mW for each increase in Ta of 1°C over 25°C (when don't mounted on a heat radiation board)

*3 Reduced by 6mW for increase in Ta of 1°C over 25°C. (when mounted on a board 70.0mm×70mm×1.6mm Glass-epoxy PCB.)

*4 Reduced by 14mW for increase in Ta of 1°C over 25°C. (when mounted on a board 70.0mm×70mm×1.6mm Glass-epoxy PCB.)

*5 Reduced by 16mW for increase in Ta of 1°C over 25°C. (when mounted on a board 70.0mm×70mm×1.6mm Glass-epoxy PCB.)

●Operating Conditions (Ta=25°C)

Parameter	Symbol	MIN	MAX	Unit
Input Voltage 1	VCC	4.5	5.5	V
Input Voltage 2	VDD	4.5	5.5	V
Input Voltage 3	VIN	4.5	28	V
BOOT Voltage	BOOT	4.5	33	V
SW Voltage	SW	-0.7	28	V
BOOT-SW Voltage	BOOT-SW	4.5	5.5	V
SLLM Input Voltage	SLLM	0	5.5	V
EN Input Voltage	EN	0	5.5	V
Output setting voltage	REF	0.7	2.0	V
Is Input Voltage	Is+/Is-	0.7	2.7	V
MIN ON Time	Tonmin	-	200	nsec

★ This product should not be used in a radioactive environment.

●ELECTRICAL CHARACTERISTICS

(unless otherwise noted, Ta=25°C VCC=5V,VDD=5V,EN/SLLM=5V,VIN=12V,REF=1.8V,RFS=68kΩ)

Parameter	Symbol	Standard Value			Unit	Condition
		MIN	TYP	MAX		
[Whole Device]						
VCC Bias Current	Icc	-	700	900	μA	
VIN Bias Current	Iin	-	100	200	μA	
VCC Standby Current	Iccstb	-	0	10	μA	EN=0V
VIN Standby Current	Iinstb	-	100	200	μA	EN=0V
EN Low Voltage	Enlow	GND	-	0.8	V	
EN High Voltage	Enhhigh	2.3	-	5.5	V	
EN Bias Current	Ien	-	7	10	μA	
VREG Voltage	Vreg	2.475	2.500	2.525	V	Ireg=100μA Ta=-10°C to 100°C*
[Under Voltage Locked Out]						
VCC threshold voltage	Vcc_UVLO	4.1	4.3	4.5	V	VCC:Sweep up
VCC hysteresis voltage	dVcc_UVLO	100	160	220	mV	VCC:Sweep down
VIN threshold voltage	Vin_UVLO	4.1	4.3	4.5	V	VIN:Sweep up
VIN hysteresis voltage	dVin_UVLO	100	160	220	mV	VIN:Sweep down
VREG threshold voltage	Vreg_UVLO	2.0	2.2	2.4	V	VREG:Sweep up
VREG hysteresis voltage	dVreg_UVLO	100	160	220	mV	VREG:Sweep down
[H ³ Reg TM]						
Frequency	Fosc	-	300	-	kHz	
ON Time	Ton	400	500	600	nsec	
MAX ON Time	Tonmax	-	3	-	μsec	
MIN OFF Time	Toffmin	-	450	550	nsec	
[FET Driver]						
HG Higher side ON resistor	HGhon	-	3.0	6.0	Ω	
HG Lower side ON resistor	HGlon	-	2.0	4.0	Ω	
LG Higher side ON resistor	LGhon	-	2.0	4.0	Ω	
LG Lower side ON resistor	LGlon	-	0.5	1.0	Ω	
[Dead Time]						
HG rising	HGdead	-	50	-	nsec	
LG rising	LGdead	-	50	-	nsec	
[SCP]						
SCP Detect Voltage	Vscp	REFx0.65	REFx0.7	REFx0.75	V	
SCP threshold voltage	Vscpth	1.2	1.25	1.3	V	
Charge current	Iscp	1.5	2	2.5	μA	
Standby voltage	Vscp_stb	-	-	50	mV	
[OVP]						
OVP Detect Voltage	VOVP	REFx1.16	REFx1.2	REFx1.24	V	
[Soft start]						
Charge current	Iss	1.5	2	2.5	μA	
Standby voltage	Vss_stb	-	-	50	mV	
[Over Current Protection Block]						
Current limit threshold1	Ilim1	43	50	57	mV	ILIM=0.5V Ta=-10°C to 100°C*
Current limit threshold2	Ilim2	160	200	240	mV	ILIM=2.0V
Reverse current limit threshold1	Rellim1	-	-50	-	mV	ILIM=0.5V
Reverse current limit threshold2	Rellim2	-	-200	-	mV	ILIM=2.0V
[VOUT setting]						
VOUT offset voltage1	Voutoff1	REF-7m	REF	REF+7m	V	Ta=-10°C to 100°C*
VOUT bias current	Ivout	-100	0	100	nA	
REF bias current	Iref	-100	0	100	nA	
Is+ Input current	IIs+	-1	0	1	μA	Is+=1.8V
Is- Input current	IIs-	-1	0	1	μA	Is-=1.8V
[SLLM]						
Continuous mode threshold	Vthcon	VCC-0.5	-	VCC	V	
SLLM threshold	VthSLLM	GND	-	0.5	V	

* Design Guarantee

●Reference Data

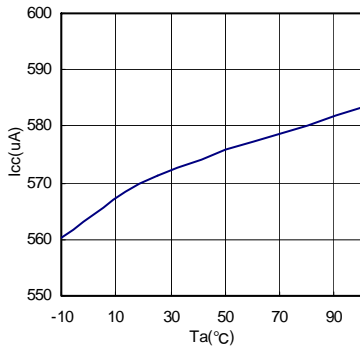

Fig.1 Ta vs Icc

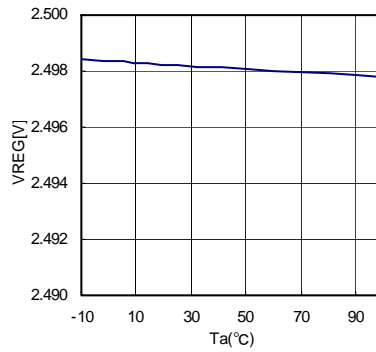

Fig.2 Ta vs VREG

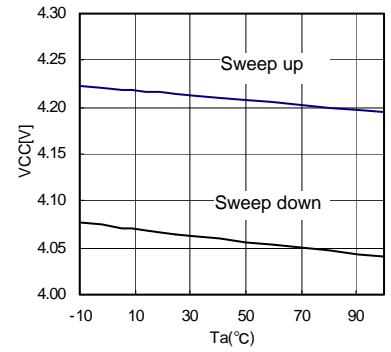

Fig.3 Ta vs UVLO (Vcc)

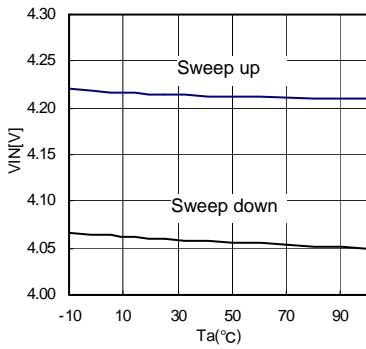

Fig.4 Ta vs UVLO (VIN)

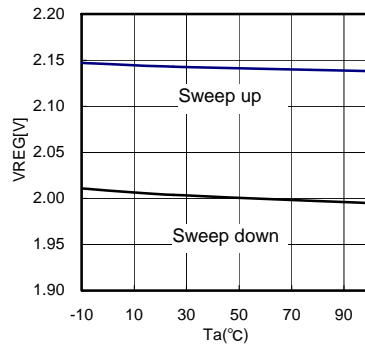

Fig.5 Ta vs UVLO (VREG)

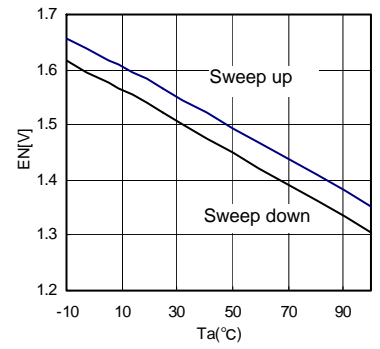

Fig.6 Ta vs EN Threshold

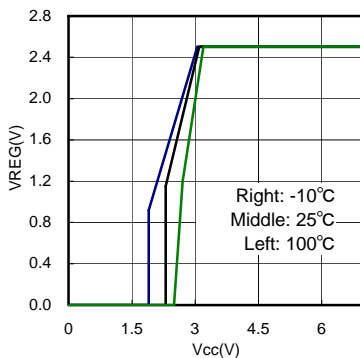

Fig.7 Vcc vs VREG (Start up)

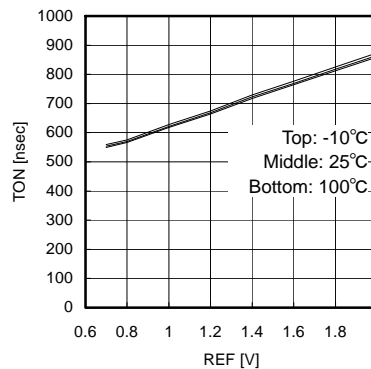

Fig.8 REF vs ON TIME (VIN=7V)

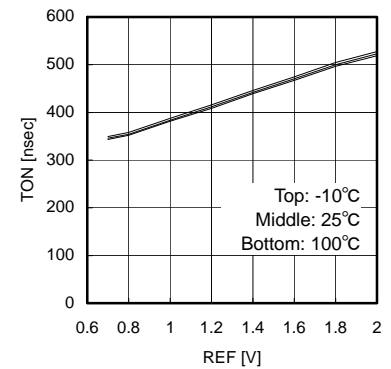

Fig.9 REF vs ON TIME (VIN=12V)

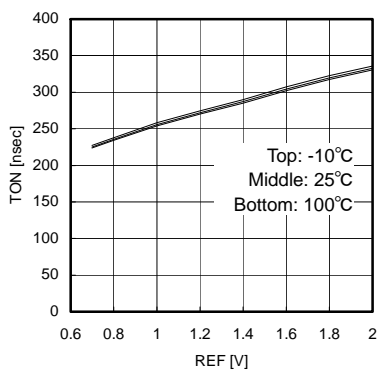

Fig.10 REF-ON TIME (VIN=25V)

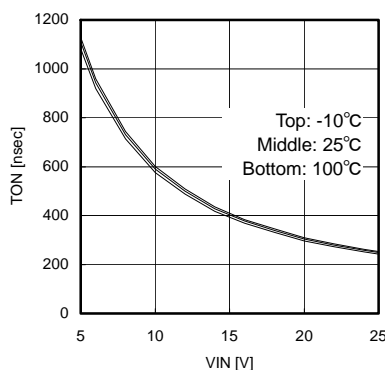

Fig.11 VIN-ON TIME (REF=1.8V)

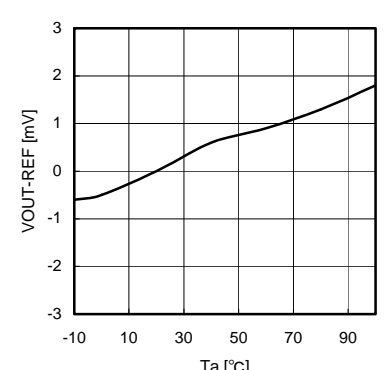

Fig.12 Ta vs VOUT offset

●Reference Data

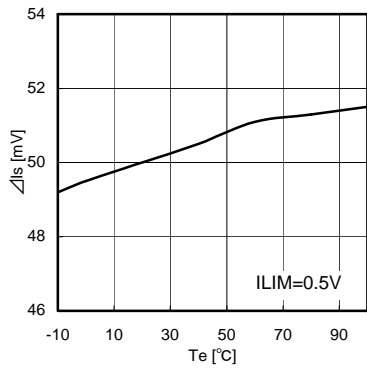

Fig.13 T_a vs current limit threshold

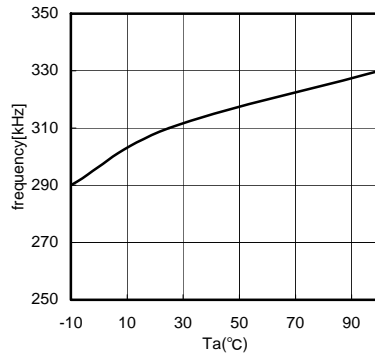

Fig.14 T_a vs Frequency

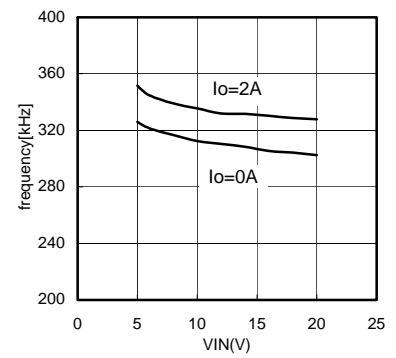

Fig.15 V_{IN} vs Frequency

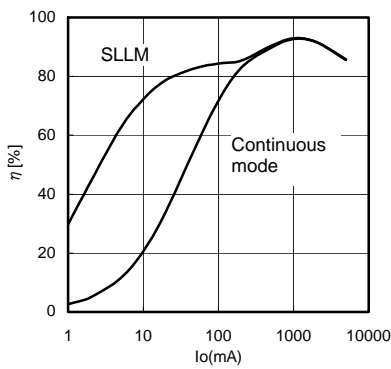

Fig.16 I_o vs Efficiency ($V_{IN}=7V$)

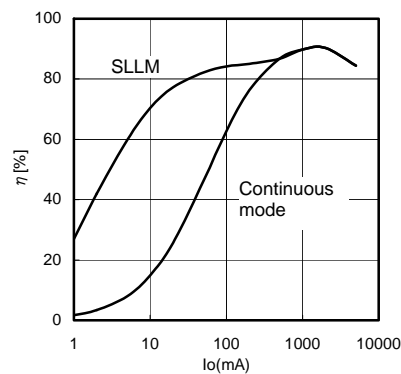

Fig.17 I_o vs Efficiency ($V_{IN}=12V$)

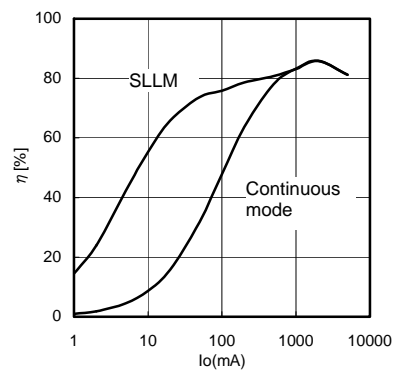

Fig.18 I_o vs Efficiency ($V_{IN}=20V$)

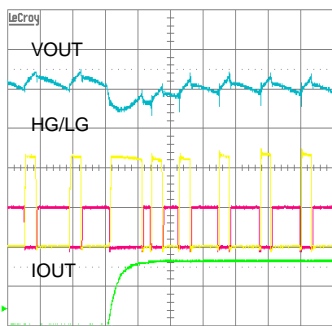

Fig.19 Load Transient Response ($V_{IN}=7V$)

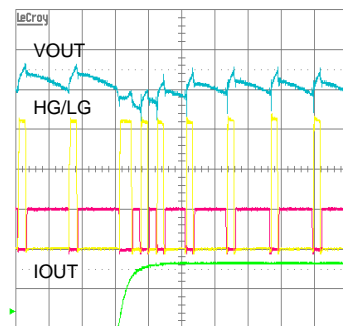

Fig.20 Load Transient Response ($V_{IN}=12V$)

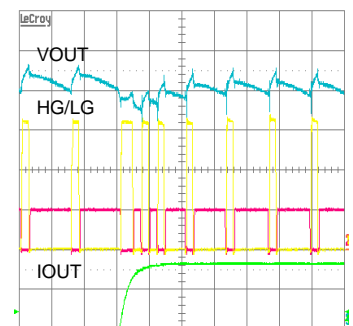

Fig.21 Load Transient Response ($V_{IN}=19V$)

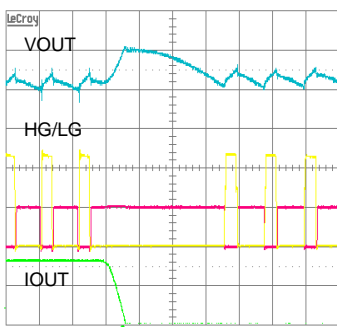

Fig.22 Load Transient Response ($V_{IN}=7V$)

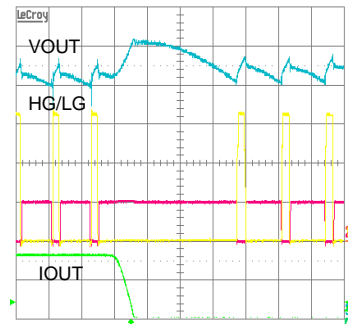

Fig.23 Load Transient Response ($V_{IN}=12V$)

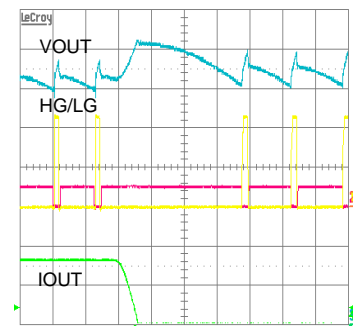

Fig.24 Load Transient Response ($V_{IN}=19V$)

●Reference Data

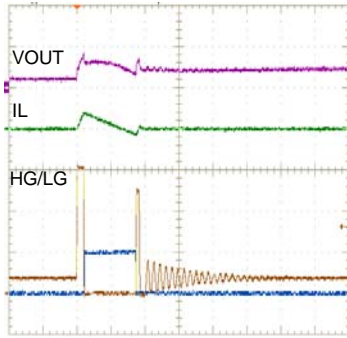

Fig.25 SLLM
(I_{OUT}=0A)

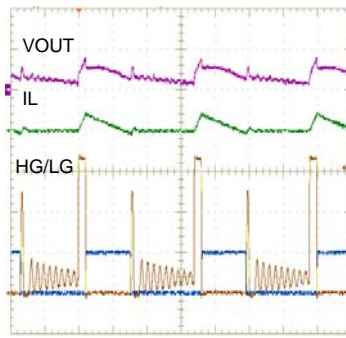

Fig.26 SLLM
(I_{OUT}=0.4A)

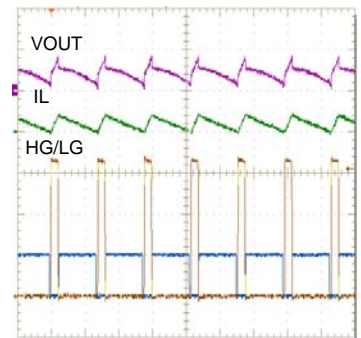

Fig.27 SLLM
(I_{OUT}=1A)

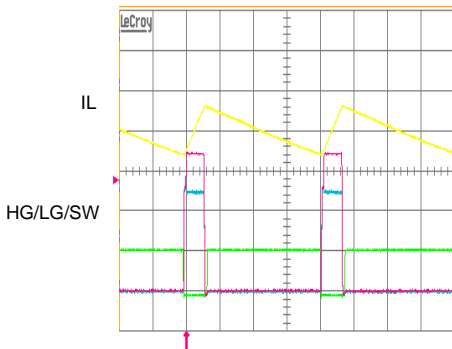

Fig.28 Continuous MODE
(I_o=0A)

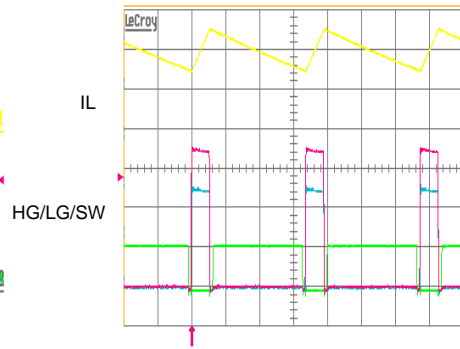

Fig.29 Continuous MODE
(I_o=0.4A)

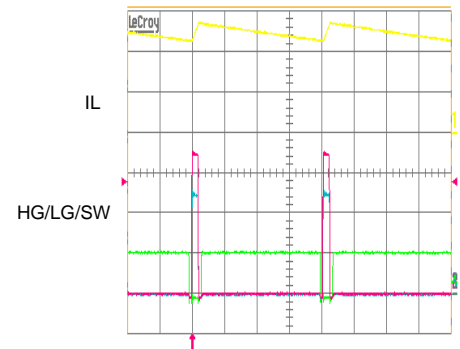

Fig.30 Continuous MODE
(I_o=5A)

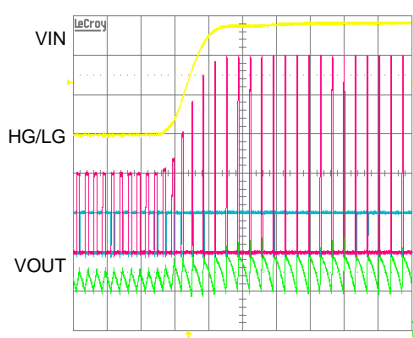

Fig.31 VIN change
(5→19V)

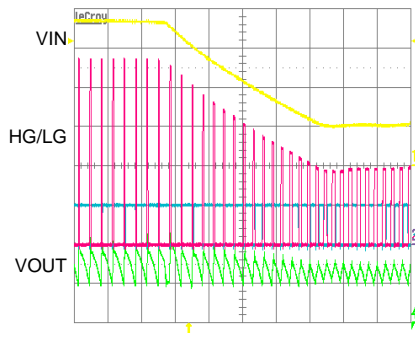

Fig.32 VIN change
(19→5V)

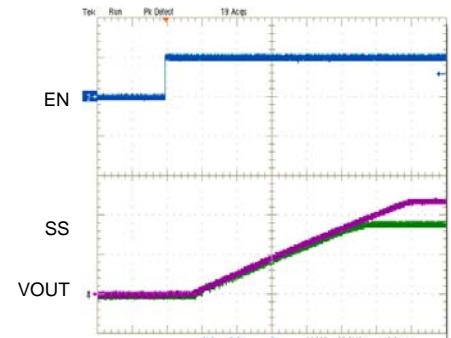

Fig.33 FS VIN wake up

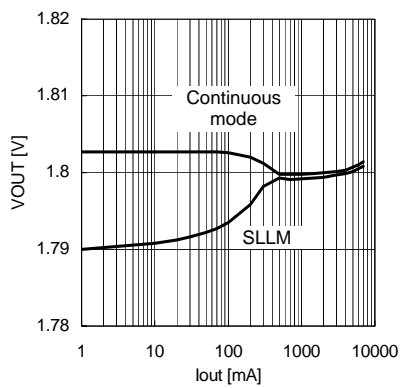

Fig.34 I_{OUT}-V_{OUT}

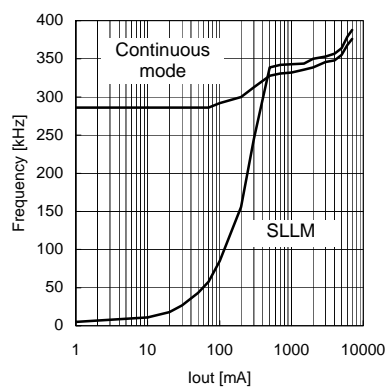

Fig.35 I_{OUT}-Frequency

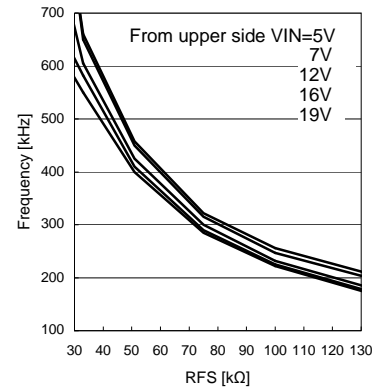
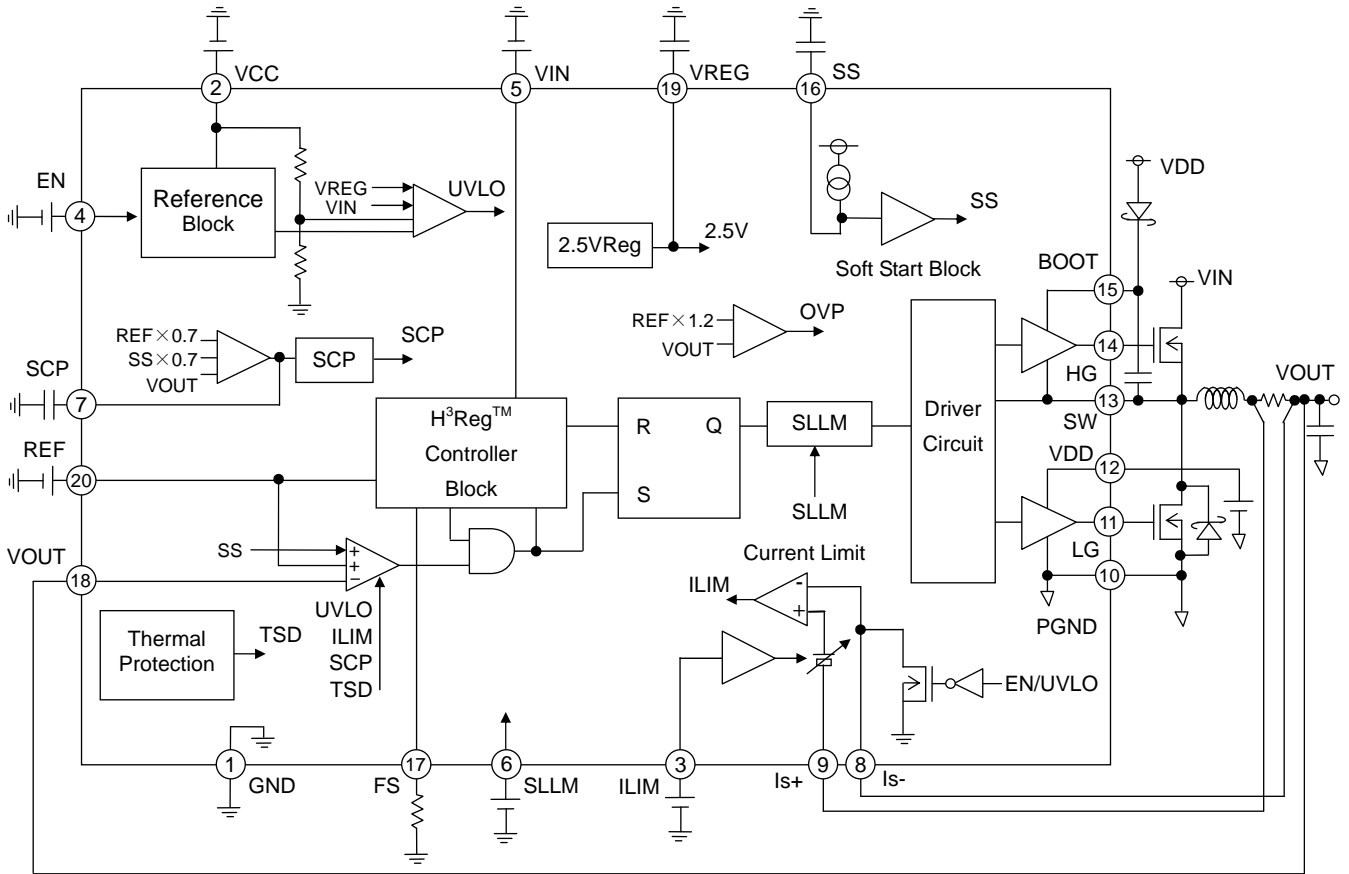
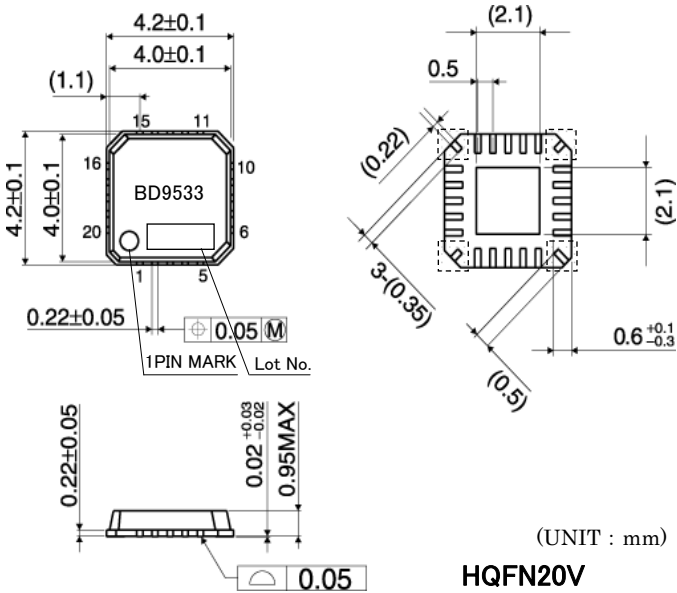

Fig.36 FS resistance- Frequency

●Block Diagram



●PHYSICAL DIMENSIONS



※ Mounting is not recommended to the dotted line part.

●Pin Number · Pin Name

Pin No.	Pin Name
1	GND
2	VCC
3	ILIM
4	EN
5	VIN
6	SLLM
7	SCP
8	IS-
9	IS+
10	PGND
11	LG
12	VDD
13	SW
14	HG
15	BOOT
16	SS
17	FS
18	VOUT
19	VREG
20	REF
-	FIN

Please short FIN to the 1PIN

●Pin Descriptions

- GND(1pin)
This is the ground pin for IC internal circuits. It is equivalent to FIN voltage.
- VCC(2pin)
This is the power supply pin for IC internal circuits, except the FET driver. The maximum circuit current is 900uA. The input supply voltage range is 4.5V to 5.5V. It is recommended that a 0.1uF bypass capacitor be put in this pin.
- ILIM(3pin)
BD9533EKN detects the voltage between Is+ pin and Is- pin and limits the output current (OCP). Voltage equivalent to 1/10 of the ILIM voltage is the voltage drop of external current sense resistor. A very low current sense resistor or inductor DCR can also be used for this platform.
- EN(4pin)
When EN pin voltage is at least 2.3V, the status of this switching regulator becomes active. Conversely, the status switches off when EN pin voltage goes lower than 0.8V and circuit current becomes 10uA.
- VIN(5pin)
The duty cycle is determined by input voltage and output voltage. In other words, the output voltage is affected by input voltage. Therefore, when VIN voltage fluctuates, the output voltage becomes also unstable. Since the VIN line is also the input voltage of the switching regulator, stability depends on the impedance of the voltage supply. It is recommended to establish a bypass capacitor or CR filter suitable for the actual application.
- SLLM(6pin)
This is the switch shift pin for Simple Light Load Mode. The efficiency in SLLM is improved when SLLM pin voltage goes lower than 0.5V.
- SCP(7pin)
This is the pin to adjust the timer latch time for short circuit protection. The timer circuit is active when the pin voltage becomes 70% of REF, and the output switches OFF and latched after the specified time. When the UVLO circuit is active or EN is low, this latch function is cancelled.
- Is-(8pin) ,Is+(9pin)
These pins are connected to both sides of the current sense resistor to detect output current. The voltage drop between Is+ and Is- is compared with the voltage equivalent to 1/10 of ILIM voltage. When this voltage drop reaches the specified voltage level, the output voltage goes OFF.
- PGND(10pin)
This is the power ground pin connected to the source of the low side FET.
- LG(11pin)
This is the voltage supply to drive the Gate of the low side FET. This voltage swings between VDD and PGND. High-speed Gate driving for the low side FET is achieved due to the low on-resistance (2 ohm when LG is high, 0.5 ohm when LG is low) of the driver.
- VDD(12pin)
This is the power supply pin to drive the LOW side FET. It is recommended that a 1uF bypass capacitor be established to compensate for rush current during the FET ON/OFF transition.
- SW(13pin)
This is the source pin for the high side FET. The maximum absolute ratings are 30V (from GND). SW voltage swings between VIN and GND.
- HG(14pin)
This is the voltage supply to drive the Gate of the high side FET. This voltage swings between BOOT and SW. High-speed Gate driving for the high side FET is achieved due to the low on-resistance (3 ohm when HG is high, 2 ohm when HG is low) of the driver.
- BOOT(15pin)
This is the voltage supply to drive the high side FET. The maximum absolute ratings are 35V (from GND) and 7V (from SW). BOOT voltage swings between VIN+Vcc and Vcc during active operation.
- SS(16pin)
This is the adjustment pin to set the soft start time. SS voltage is low during standby status. When EN is ON, the soft start time can be determined by the SS charge current and capacitor between SS-GND. Until SS reaches REF voltage, the output voltage is equivalent to SS voltage.
- FS(17pin)
This is the pin to adjust the switching frequency based on the resistor value. The frequency range is $f=200\text{KHz} - 600\text{KHz}$.
- VOUT(18pin)
This is the output voltage sense pin. It is also possible to adjust the output voltage using external resistor divider based on the equation, $\text{REF} \doteq \text{VOUT}$.
- VREG(19pin)
This is the reference voltage output pin. The voltage is 2.5V, with 100uA current ability. It is recommended that a 1uF capacitor (X5R or X7R) be established between VREG and GND. When REF is not adjusted from the external voltage supply, the REF voltage can be adjusted using the external resistor divider of VREF.
- REF(20pin)
This is the output voltage adjustment pin. It is very convenient for synchronizing external voltage supply. The IC controls the output voltage ($\text{REF} \doteq \text{VOUT}$).

●Explanation of Operation

The BD9533EKN is a synchronous buck regulator controller incorporating ROHM's proprietary H³Reg™ CONTROLLA control system. When V_{OUT} drops due to a rapid load change, the system quickly restores V_{OUT} by extending the T_{ON} time interval. Thus, it serves to improve the regulator's transient response. Activating the Light Load Mode will also exercise Simple Light Load Mode (SLLM) control when the load is light, to further increase efficiency.

H³Reg™ control
(Normal operation)

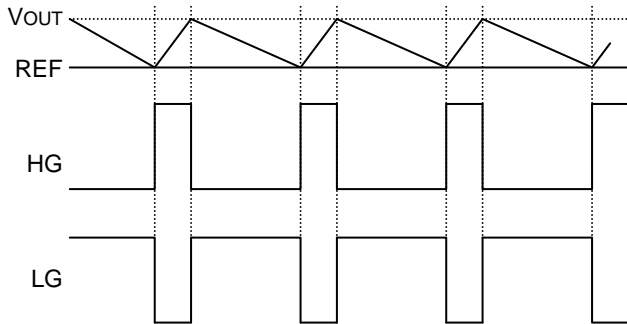

When V_{OUT} falls to a threshold voltage (REF), the drop is detected, activating the H³Reg™ CONTROLLA system.

$$T_{ON} = \frac{REF}{V_{IN}} \times \frac{1}{f} \text{ [sec]} \dots (1)$$

HG output is determined with the formula above. LG outputs until the status of V_{OUT} is lower than REF after the status of HG is off.

(V_{OUT} drops due to a rapid load change)

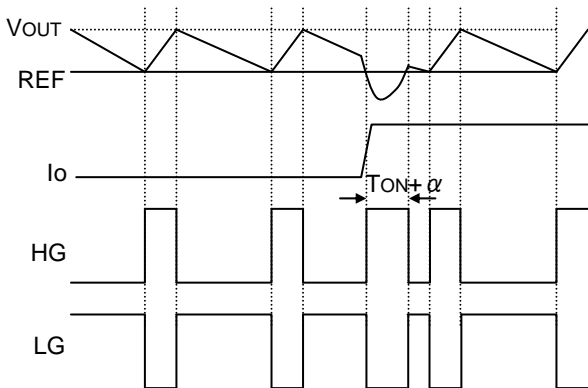

When V_{OUT} drops due to a rapid load change, and the voltage remains below REF after the programmed T_{ON} time interval has elapsed, the system quickly restores V_{OUT} by extending the T_{ON} time, improving the transient response.

(SLLM)

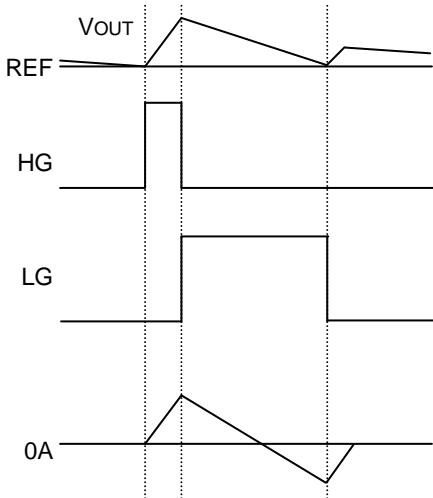

In SLLM (SLLM=0V), SLLM function is operated when LG pin is OFF and the coil current is lower than 0A (the current goes from V_{OUT} to SW). And it stops to output next HG.

When V_{OUT} goes lower than REF voltage again, the status of HG is ON.

- Timing Chart
- Soft Start Function

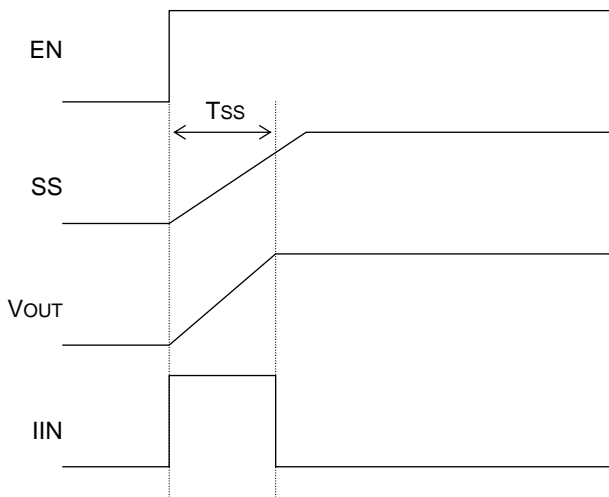

Soft start is exercised with the EN pin set high. Current control takes effect at startup, enabling a moderate output voltage “ramping start.” Soft start timing and incoming current are calculated with formulas (2) and (3) below.

Soft start time

$$T_{ss} = \frac{REF \times C_{ss}}{2 \mu A (typ)} \text{ [sec]} \dots (2)$$

Incoming current

$$I_{IN} = \frac{C_o \times V_{OUT}}{T_{ss}} \text{ [A]} \dots (3)$$

(C_{ss}: Soft start capacitor; C_o: Output capacitor)

- Timer Latch Type Short Circuit Protection

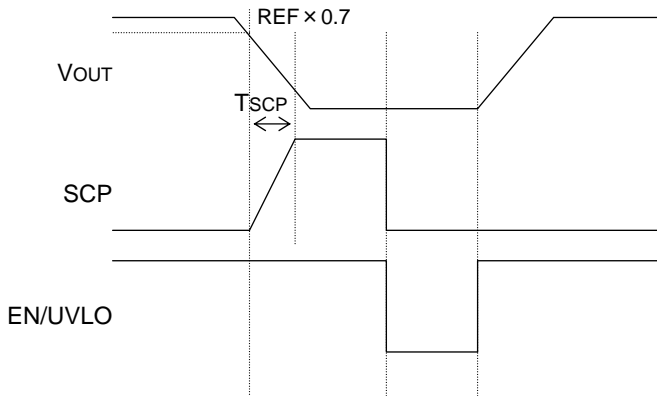

Short protection kicks in when output falls to or below REF X 0.7. When the programmed time period elapses, output is latched OFF to prevent destruction of the IC. Output voltage can be restored either by reconnecting the EN pin or disabling UVLO. Short circuit protection time is programmed using formula (4) below.

Short protection time setting

$$T_{scp} = \frac{1.25(V) \times C_{SCP}}{2 \mu A (typ)} \text{ [sec]} \dots (4)$$

- Over Voltage Protection

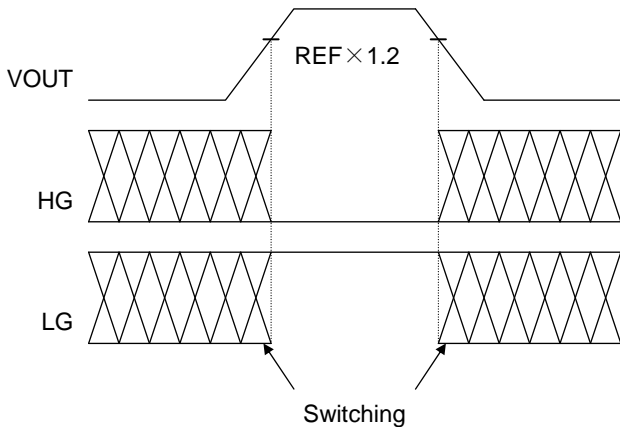

●External Component Selection

1. Inductor (L) selection

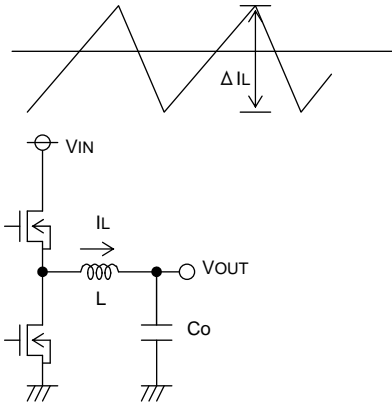

Output ripple current

The inductor value is a major influence on the output ripple current. As formula (5) below indicates, the greater the inductor or the switching frequency, the lower the ripple current.

$$\Delta I_L = \frac{(V_{IN} - V_{OUT}) \times V_{OUT}}{\Delta I_L \times V_{IN} \times f} \text{ [A]} \dots (5)$$

The proper output ripple current setting is about 30% of maximum output current.

$$\Delta I_L = 0.3 \times I_{OUTmax.} \text{ [A]} \dots (6)$$

$$L = \frac{(V_{IN} - V_{OUT}) \times V_{OUT}}{\Delta I_L \times V_{IN} \times f} \text{ [H]} \dots (7)$$

(ΔI_L : output ripple current; f: switch frequency)

※Passing a current larger than the inductor's rated current will cause magnetic saturation in the inductor and decrease system efficiency. In selecting the inductor, be sure to allow enough margin to assure that peak current does not exceed the inductor rated current value.

※To minimize possible inductor damage and maximize efficiency, choose a inductor with a low (DCR, ACR) resistance.

2. Output Capacitor (Co) Selection

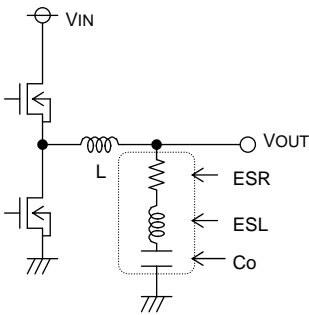

Output capacitor

When determining the proper output capacitor, be sure to factor in the equivalent series resistance required to smooth out ripple volume and maintain a stable output voltage range.

Output ripple voltage is determined as in formula (8) below.

$$\Delta V_{OUT} = \Delta I_L \times ESR + ESL \times \Delta I_L / T_{ON} \text{ [V]} \dots (8)$$

(ΔI_L : Output ripple current; ESR: Co equivalent series resistance, ESL: equivalent series inductance)

※ In selecting a capacitor, make sure the capacitor rating allows sufficient margin relative to output voltage. Note that a lower ESR can minimize output ripple voltage.

Please give due consideration to the conditions in formula (9) below for output capacity, bearing in mind that output rise time must be established within the soft start time frame.

$$C_o \leq \frac{T_{ss} \times (\text{Limit} - I_{OUT})}{V_{OUT}} \dots (9)$$

T_{ss}: Soft start time
Limit: Over current detection

Note: Improper capacitor may cause startup malfunctions.

3. Input Capacitor (Cin) Selection

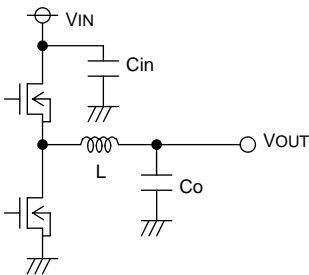

Input Capacitor

The input capacitor selected must have low enough ESR resistance to fully support large ripple output, in order to prevent extreme over current. The formula for ripple current IRMS is given in (10) below.

$$I_{RMS} = I_{OUT} \times \frac{\sqrt{V_{OUT}(V_{IN} - V_{OUT})}}{V_{IN}} \text{ [A]} \dots (10)$$

Where $V_{CC} = 2 \times V_{OUT}$, $I_{RMS} = \frac{I_{OUT}}{2}$

A low ESR capacitor is recommended to reduce ESR loss and maximize efficiency.

4. MOSFET Selection

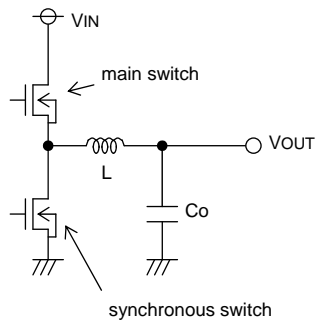

Loss on the main MOSFET

$$P_{main} = P_{RON} + P_{GATE} + P_{TRAN}$$

$$= \frac{V_{OUT}}{V_{IN}} \times R_{ON} \times I_{OUT}^2 + C_{iss} \times f \times V_{DD} + \frac{V_{IN}^2 \times C_{rss} \times I_{OUT} \times f}{I_{DRIVE}} \dots (11)$$

(R_{ON} : On-resistance of FET; C_{iss} : FET gate capacity;
 f : Switching frequency C_{rss} : FET inverse transfer function;
 I_{DRIVE} : Gate peak current)

Loss on the synchronous MOSFET

$$P_{syn} = P_{RON} + P_{GATE}$$

$$= \frac{V_{IN} - V_{OUT}}{V_{IN}} \times R_{ON} \times I_{OUT}^2 + C_{iss} \times f \times V_{DD} \dots (12)$$

5. Setting Detection Resistance

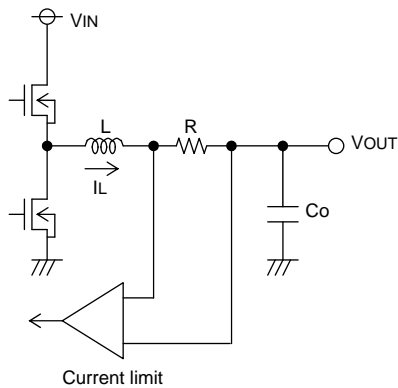

The over current protection function detects the output ripple current peak value. This parameter (setting value) is determined as in formula (13) below.

$$I_{LIMIT} = \frac{V_{ILIM} \times 0.1}{R} [A] \dots (13)$$

(V_{ILIM} : I_{LIM} voltage; R : Detection resistance)

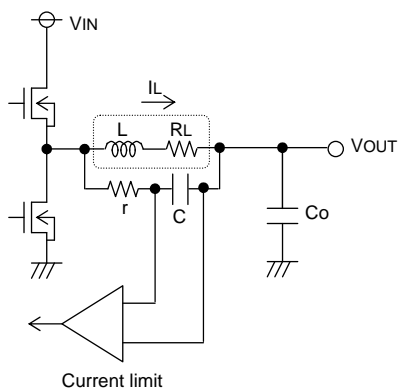

When the over current protection is detected by DCR of coil L, this parameter (setting value) is determined as in formula (14) below.
 (Application circuit: P20)

$$I_{LIMIT} = V_{ILIM} \times 0.1 \times \frac{r \times C}{L} [A] \dots (14)$$

$$(R_L = \frac{L}{r \times C})$$

(V_{ILIM} : I_{LIM} voltage R_L : the DCR value of coil)

6. Setting frequency

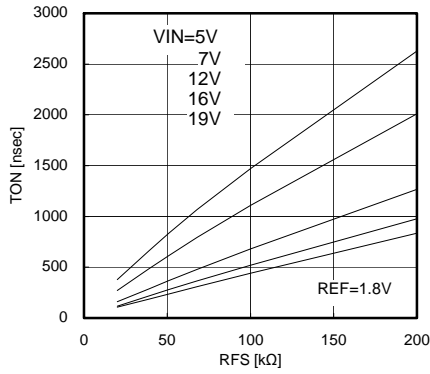

↓
Calculated frequency using TON above

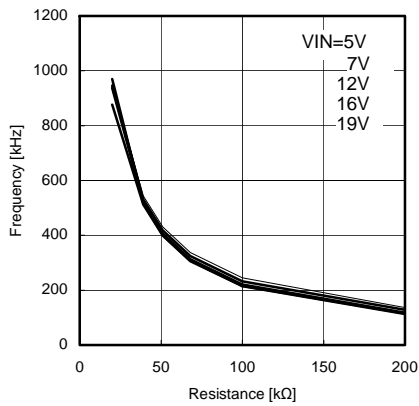

On Time (TON) at steady state is determined by resistance value connected to FS pin as shown in the figure. The frequency can be calculated with TON, input voltage VIN, the reference voltage REF as follows.

$$F = \frac{REF}{VIN \times TON} \dots (15)$$

However, the actual frequency becomes lower than the formula due to expanded TON time caused by the rise/fall time of the MOSFET (This rise/fall time is affected by the switching speed). TON is also influenced by Dead Time under light load in continuous mode. In this case the frequency becomes lower than setting frequency.

The setting frequency noted above is under heavy load (when the inductor current does not go back to VIN through the body diodes of the external MOSFET's).

7. Setting standard voltage (REF)

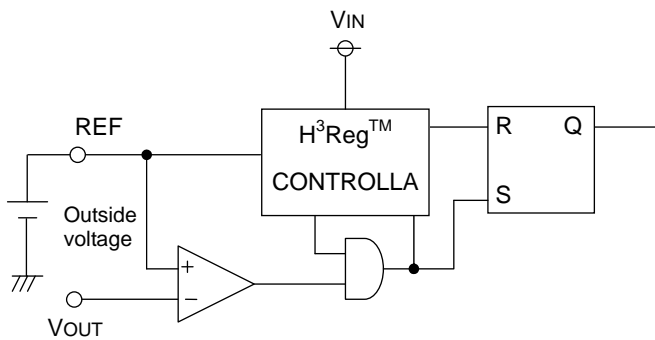

It is available to synchronize setting the reference voltage (REF) with outside supply voltage [V] by using outside power supply voltage.

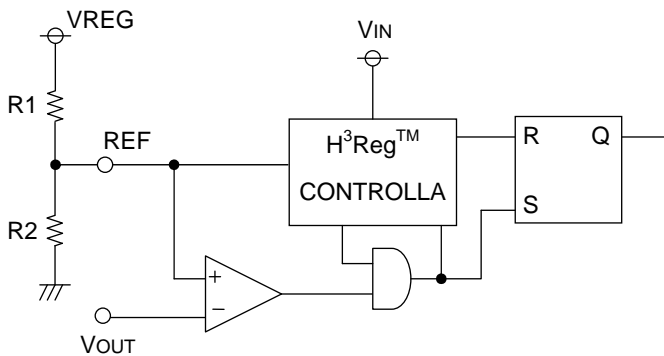

It is available to set the reference voltage (REF) by the resistance division value from VREG in case it is not set REF from an external power supply.

$$REF = \frac{R2}{R1+R2} \times VREG [V] \dots (16)$$

8. Setting output voltage

This IC is operated that output voltage is $REF \cong VOUT$.

And it is operated that output voltage is feed back to FB pin in case the output voltage is 0.7V to 2.0V.

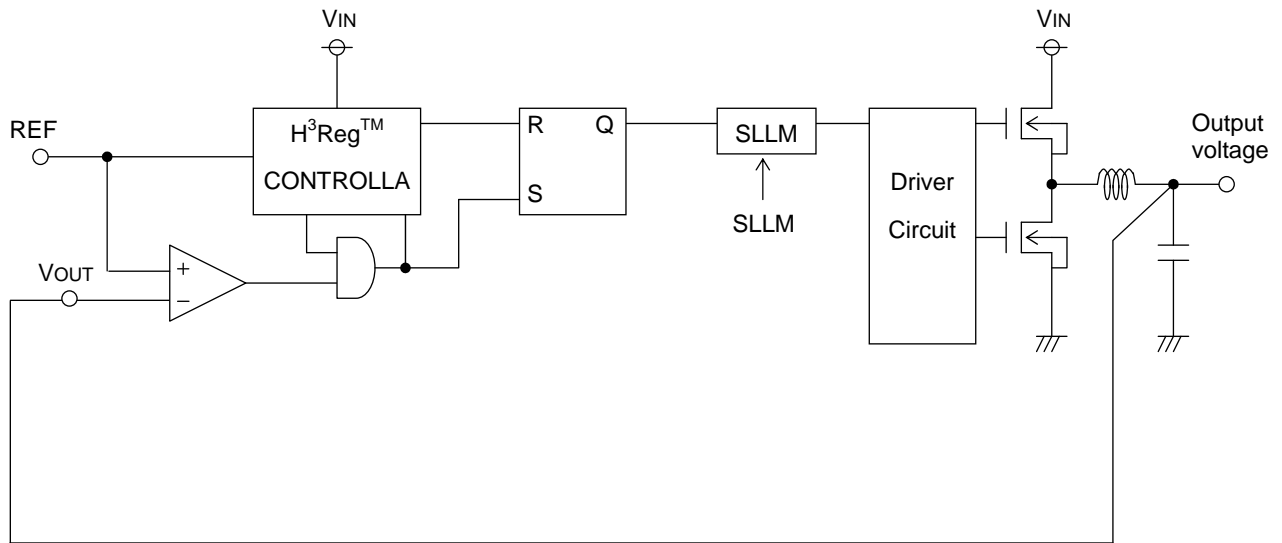

In case the output voltage range is 0.7V to 2.0V.

It is operated that the resistance division value of the output voltage is feed back to VOUT pin in case the output voltage is more than 2.0V.

$$\text{output voltage} \cong \frac{R1+R2}{R2} \times REF [V] \cdot \cdot \cdot (17)$$

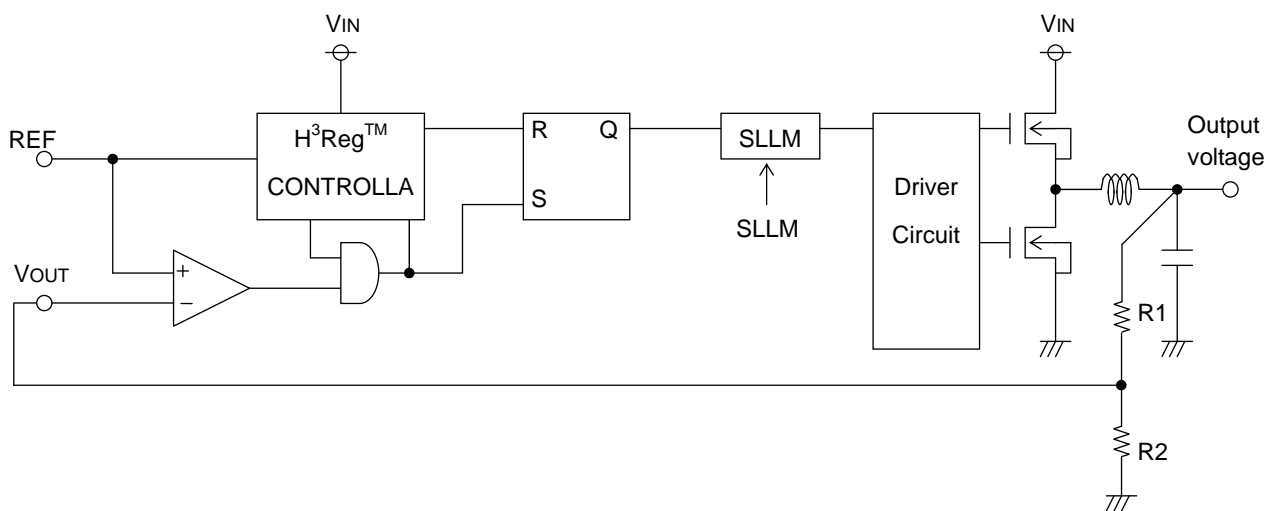

In case the output voltage is more than 2.0V.

●I/O Equivalent Circuit

3pin (ILIM)

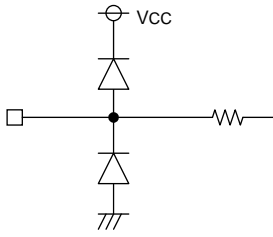

4pin (EN)

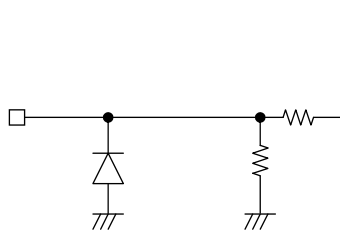

5pin (VIN)

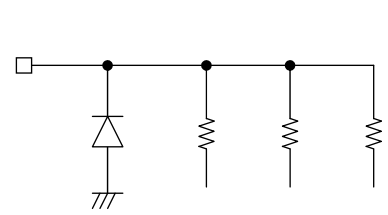

6pin (SLLM)

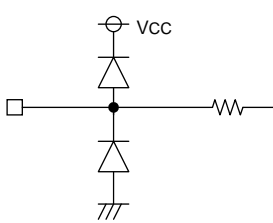

7pin (SCP)

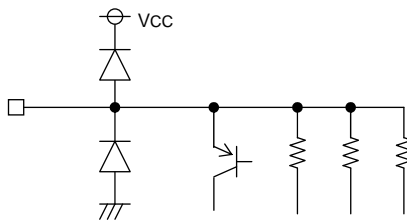

8pin (Is-)

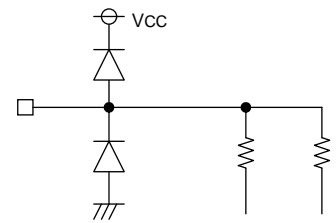

9pin (Is+)

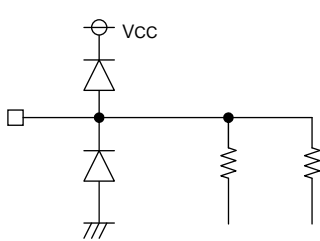

11pin (LG)

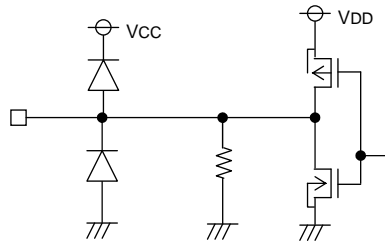

13pin (SW)

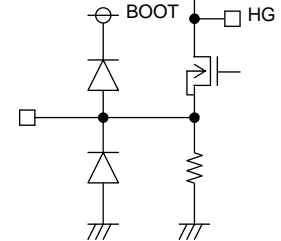

14pin (HG)

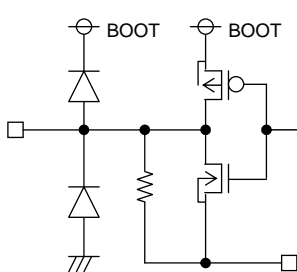

15pin (BOOT)

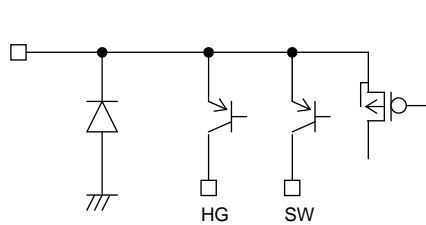

16pin (SS)

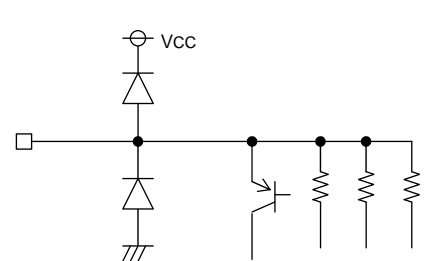

17pin (FS)

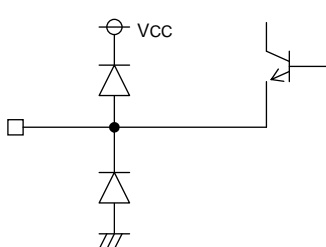

18pin (VOUT)

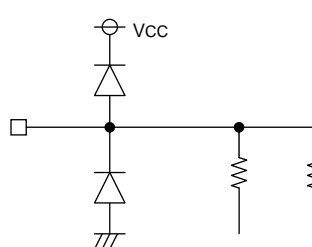

19pin (VREG)

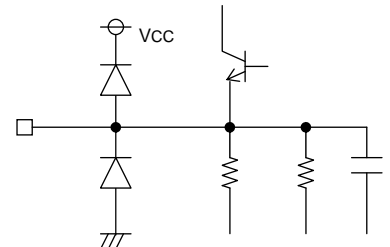

20pin (REF)

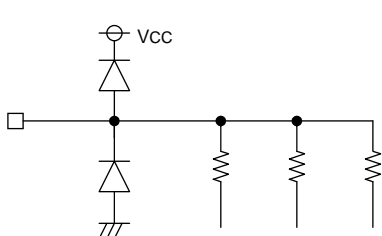

●Evaluation Board Circuit (Frequency=300kHz application circuit in Continuous mode/SLLM)

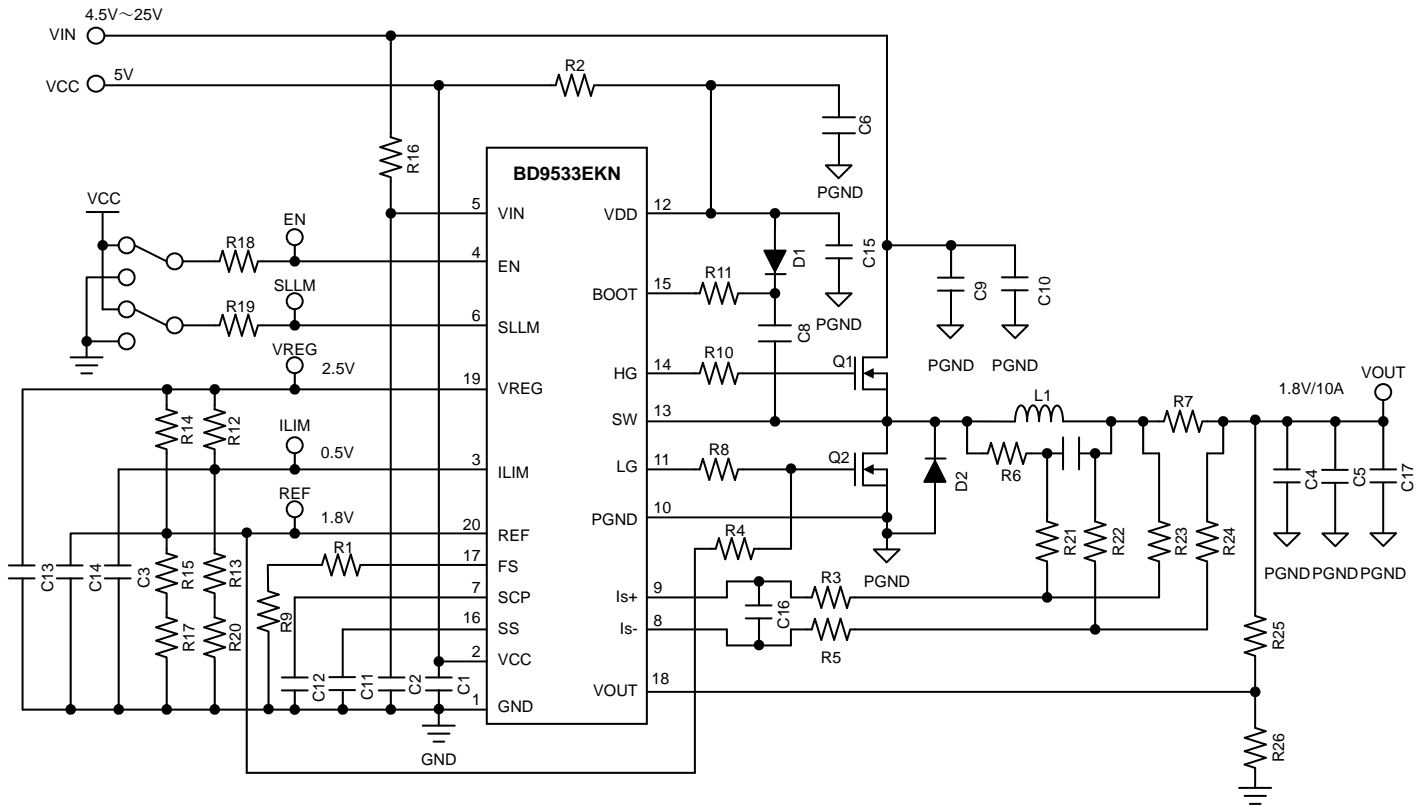

Part No	Value	Company	Part name
U1		ROHM	BD9533EKN
Q1		ROHM	RSS100N03
Q2		ROHM	RSS100N03
D1		ROHM	RB521S-30
D2		ROHM	RB051L-40
C1	1uF	KYOCERA	CM105B105K06A
C2	10nF	MURATA	GRM39X7R103K50
C3	100pF	MURATA	GRM39C0G101J50
C4			
C5			
C6	10uF	KYOCERA	CM21B106K06
C7			
C8	0.1uF	KYOCERA	CM05B104K25A
C9	10uF	KYOCERA	CM316B106M16A
C10	10uF	KYOCERA	CM316B106M16A
C11	1000pF	MURATA	GRM39X7R102K50
C12	1500pF	MURATA	GRM39X7R152K50
C13	1uF	KYOCERA	CM105B105K06A
C14			
C15	10uF	KYOCERA	CM21B106M06A
C16			
C17	470uF	SANYO	2R5TPE470ML
R1	68kΩ	ROHM	MCR03
R2	0Ω	ROHM	MCR03
R3	0Ω	ROHM	MCR03

Part No	Value	Company	Part name
R4			
R5	0Ω	ROHM	MCR03
R6			
R7	5mΩ	ROHM	PMR100
R8	0Ω	ROHM	MCR03
R9	0Ω	ROHM	MCR03
R10	0Ω	ROHM	MCR03
R11	0Ω	ROHM	MCR03
R12	200kΩ	ROHM	MCR03
R13	51kΩ	ROHM	MCR03
R14	68kΩ	ROHM	MCR03
R15	180kΩ	ROHM	MCR03
R16	1kΩ	ROHM	MCR03
R17	0Ω	ROHM	MCR03
R18	10kΩ	ROHM	MCR03
R19	10kΩ	ROHM	MCR03
R20	0Ω	ROHM	MCR03
R21			
R22			
R23	0Ω	ROHM	MCR03
R24	0Ω	ROHM	MCR03
R25	0Ω	ROHM	MCR03
R26			
L1	1.8uH	SUMIDA	CDEP104-1R8ML

●Evaluation Board Circuit (Frequency=300kHz application circuit for detecting DCR current in Continuous mode/SLLM)

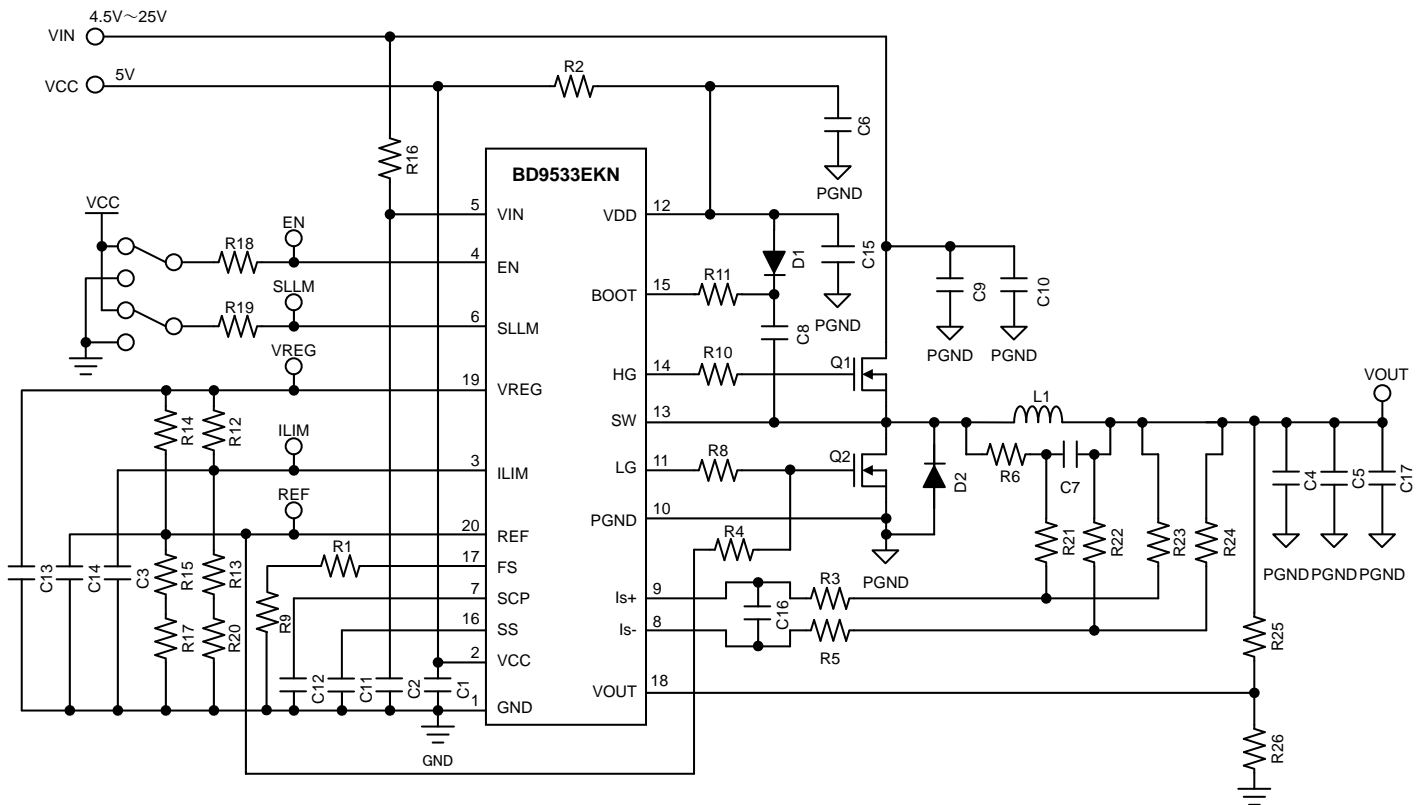

●Evaluation Board Parts List

Part No	Value	Company	Part name
U1		ROHM	BD9533EKN
Q1		ROHM	RSS100N03
Q2		ROHM	RSS100N03
D1		ROHM	RB521S-30
D2		ROHM	RB051L-40
C1	1uF	KYOCERA	CM105B105K06A
C2	10nF	MURATA	GRM39X7R103K50
C3	100pF	MURATA	GRM39C0G101J50
C4			
C5			
C6	10uF	KYOCERA	CM21B106K06
C7	0.1uF	KYOCERA	CM05B104K25A
C8	0.1uF	KYOCERA	CM05B104K25A
C9	10uF	KYOCERA	CM316B106M16A
C10	10uF	KYOCERA	CM316B106M16A
C11	1000pF	MURATA	GRM39X7R102K50
C12	1500pF	MURATA	GRM39X7R152K50
C13	1uF	KYOCERA	CM105B105K06A
C14			
C15	10uF	KYOCERA	CM21B106M06A
C16			
C17	330uF	SANYO	6TPB330M
R1	68KΩ	ROHM	MCR03
R2	0Ω	ROHM	MCR03
R3	0Ω	ROHM	MCR03

Part No	Value	Company	Part name
R4			
R5	0Ω	ROHM	MCR03
R6	1kΩ	ROHM	MCR03
R7			
R8	0Ω	ROHM	MCR03
R9	0Ω	ROHM	MCR03
R10	0Ω	ROHM	MCR03
R11	0Ω	ROHM	MCR03
R12	51kΩ	ROHM	MCR03
R13	200kΩ	ROHM	MCR03
R14	68kΩ	ROHM	MCR03
R15	180kΩ	ROHM	MCR03
R16	1kΩ	ROHM	MCR03
R17	0Ω	ROHM	MCR03
R18	10kΩ	ROHM	MCR03
R19	10kΩ	ROHM	MCR03
R20	0Ω	ROHM	MCR03
R21	0Ω	ROHM	MCR03
R22	0Ω	ROHM	MCR03
R23			
R24			
R25	0Ω	ROHM	MCR03
R26			
L1	3.3uH	NEC/TOKIN	MPLC0730L3R3

●Operation Notes

1. Absolute maximum ratings

An excess in the absolute maximum ratings, such as supply voltage, temperature range of operating conditions, etc., can break down the devices, thus making impossible to identify breaking mode, such as a short circuit or an open circuit. If any over rated values will expect to exceed the absolute maximum ratings, consider adding circuit protection devices, such as fuses.

2. Connecting the power supply connector backward

Connecting of the power supply in reverse polarity can damage IC. Take precautions when connecting the power supply lines. An external direction diode can be added.

3. Power supply lines

Design PCB layout pattern to provide low impedance GND and supply lines. To obtain a low noise ground and supply line, separate the ground section and supply lines of the digital and analog blocks. Furthermore, for all power supply terminals to ICs, connect a capacitor between the power supply and the GND terminal. When applying electrolytic capacitors in the circuit, not that capacitance characteristic values are reduced at low temperatures.

4. GND voltage

The potential of GND pin must be minimum potential in all operating conditions.

5. Thermal design

Use a thermal design that allows for a sufficient margin in light of the power dissipation (Pd) in actual operating conditions.

6. Inter-pin shorts and mounting errors

Use caution when positioning the IC for mounting on printed circuit boards. The IC may be damaged if there is any connection error or if pins are shorted together.

7. Actions in strong electromagnetic field

Use caution when using the IC in the presence of a strong electromagnetic field as doing so may cause the IC to malfunction.

8. ASO

When using the IC, set the output transistor so that it does not exceed absolute maximum ratings or ASO.

9. Thermal shutdown circuit

The IC incorporates a built-in thermal shutdown circuit (TSD circuit). The thermal shutdown circuit (TSD circuit) is designed only to shut the IC off to prevent thermal runaway. It is not designed to protect the IC or guarantee its operation. Do not continue to use the IC after operating this circuit or use the IC in an environment where the operation of this circuit is assumed.

	TSD on temperature [°C] (typ.)	Hysteresis temperature [°C] (typ.)
BD9533EKN	175	15

10. Testing on application boards

When testing the IC on an application board, connecting a capacitor to a pin with low impedance subjects the IC to stress. Always discharge capacitors after each process or step. Always turn the IC's power supply off before connecting it to or removing it from a jig or fixture during the inspection process. Ground the IC during assembly steps as an antistatic measure. Use similar precaution when transporting or storing the IC.

11. Regarding input pin of the IC

This monolithic IC contains P+ isolation and P substrate layers between adjacent elements in order to keep them isolated. P-N junctions are formed at the intersection of these P layers with the N layers of other elements, creating a parasitic diode or transistor. For example, the relation between each potential is as follows:

When $GND > Pin A$ and $GND > Pin B$, the P-N junction operates as a parasitic diode.

When $GND > Pin B$, the P-N junction operates as a parasitic transistor.

Parasitic diodes can occur inevitable in the structure of the IC. The operation of parasitic diodes can result in mutual interference among circuits, operational faults, or physical damage. Accordingly, methods by which parasitic diodes operate, such as applying a voltage that is lower than the GND (P substrate) voltage to an input pin, should not be used.

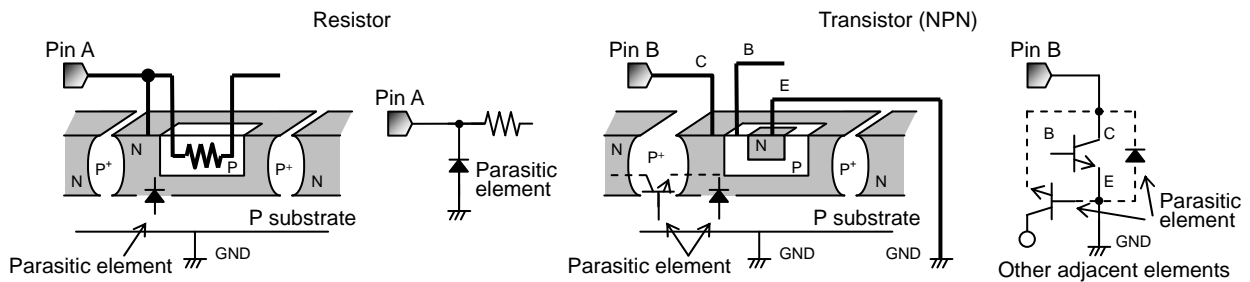
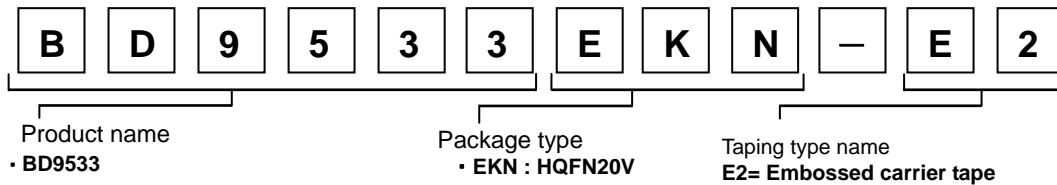

Fig. 37 Example of IC structure

12. Ground Wiring Pattern

When using both small signal and large current GND patterns, it is recommended to isolate the two ground patterns, placing a single ground point at the ground potential of application so that the pattern wiring resistance and voltage variations caused by large currents do not cause variations in the small signal ground voltage. Be careful not to change the GND wiring pattern of any external components, either.

●Type Designations (Selections) for Ordering



HQFN20V

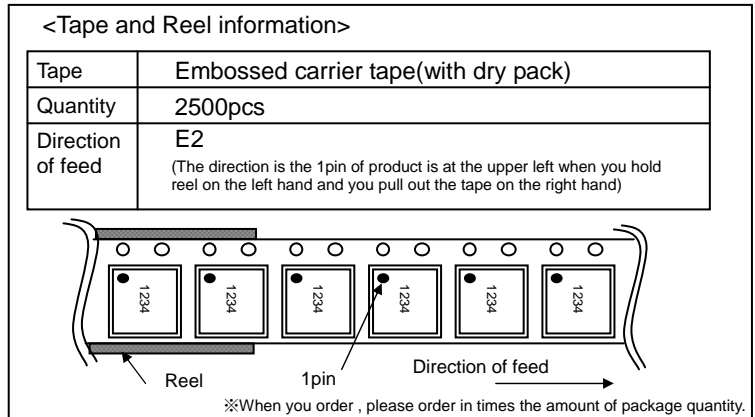
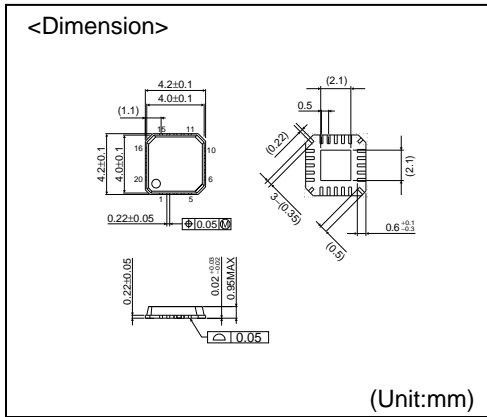

- The contents described herein are correct as of September, 2008
- The contents described herein are subject to change without notice. For updates of the latest information, please contact and confirm with ROHM CO.,LTD.
- Any part of this application note must not be duplicated or copied without our permission.
- Application circuit diagrams and circuit constants contained herein are shown as examples of standard use and operation. Please pay careful attention to the peripheral conditions when designing circuits and deciding upon circuit constants in the set.
- Any data, including, but not limited to application circuit diagrams and information, described herein are intended only as illustrations of such devices and not as the specifications for such devices. ROHM CO.,LTD. disclaims any warranty that any use of such devices shall be free from infringement of any third party's intellectual property rights or other proprietary rights, and further, assumes no liability of whatsoever nature in the event of any such infringement, or arising from or connected with or related to the use of such devices.
- Upon the sale of any such devices, other than for buyer's right to use such devices itself, resell or otherwise dispose of the same, implied right or license to practice or commercially exploit any intellectual property rights or other proprietary rights owned or controlled by ROHM CO., LTD. is granted to any such buyer.
- The products described herein utilize silicon as the main material.
- The products described herein are not designed to be X ray proof.

The products listed in this catalog are designed to be used with ordinary electronic equipment or devices (such as audio visual equipment, office-automation equipment, communications devices, electrical appliances and electronic toys). Should you intend to use these products with equipment or devices which require an extremely high level of reliability and the malfunction of which would directly endanger human life (such as medical instruments, transportation equipment, aerospace machinery, nuclear-reactor controllers, fuel controllers and other safety devices), please be sure to consult with our sales representative in advance.

Contact us for further information about the products.

- | | | | | | |
|-----------------------|------------------------|------------------------|---------------------|------------------------|------------------------|
| San Diego | TEL: +1-858-625-3630 | FAX: +1-858-625-3670 | Tianjin | TEL: +86-22-3029181 | FAX: +86-22-3029183 |
| Atlanta | TEL: +1-770-754-5972 | FAX: +1-770-754-0691 | Shanghai | TEL: +86-21-6279-2727 | FAX: +86-21-6247-2066 |
| Boston | TEL: +1-978-371-0382 | FAX: +1-928-438-7164 | Hangzhou | TEL: +86-571-87658072 | FAX: +86-571-87658071 |
| Chicago | TEL: +1-847-368-1006 | FAX: +1-847-368-1008 | Nanjing | TEL: +86-25-8689-0015 | FAX: +86-25-8689-0393 |
| Dallas | TEL: +1-469-287-5366 | FAX: +1-469-362-7973 | Ningbo | TEL: +86-574-87654201 | FAX: +86-574-87654208 |
| Denver | TEL: +1-303-708-0908 | FAX: +1-303-708-0858 | Qingdao | TEL: +86-532-5779-312 | FAX: +86-532-5779-653 |
| Detroit | TEL: +1-248-348-9920 | FAX: +1-248-348-9942 | Suzhou | TEL: +86-512-6807-1300 | FAX: +86-512-6807-2300 |
| Nashville | TEL: +1-615-620-6700 | FAX: +1-615-620-6702 | Wuxi | TEL: +86-510-82702693 | FAX: +86-510-82702992 |
| Mexico | TEL: +52-33-3123-2001 | FAX: +52-33-3123-2002 | Shenzhen | TEL: +86-755-8307-3008 | FAX: +86-755-8307-3003 |
| Düsseldorf | TEL: +49-2154-9210 | FAX: +49-2154-921400 | Dongguan | TEL: +86-769-8393-3320 | FAX: +86-769-8398-4140 |
| Munich | TEL: +49-8999-216168 | FAX: +49-8999-216176 | Fuzhou | TEL: +86-591-8801-8698 | FAX: +86-591-8801-8690 |
| Stuttgart | TEL: +49-711-7272-370 | FAX: +49-711-7272-3720 | Guangzhou | TEL: +86-20-3878-8100 | FAX: +86-20-3825-5965 |
| France | TEL: +33-1-5697-3060 | FAX: +33-1-5697-3080 | Huizhou | TEL: +86-752-205-1054 | FAX: +86-752-205-1059 |
| United Kingdom | TEL: +44-1-908-306700 | FAX: +44-1-908-235788 | Xiamen | TEL: +86-592-238-5705 | FAX: +86-592-239-8380 |
| Denmark | TEL: +45-3694-4739 | FAX: +45-3694-4789 | Zhuhai | TEL: +86-756-3232-480 | FAX: +86-756-3232-460 |
| Espoo | TEL: +358-9725-54491 | FAX: +358-9-7255-4499 | Hong Kong | TEL: +852-2-740-6262 | FAX: +852-2-375-8971 |
| Salo | TEL: +358-2-7332234 | FAX: +358-2-7332237 | Taipei | TEL: +886-2-2500-6956 | FAX: +886-2-2503-2869 |
| Oulu | TEL: +358-9-5372930 | FAX: +358-8-5372931 | Kaohsiung | TEL: +886-7-237-0881 | FAX: +886-7-238-7332 |
| Barcelona | TEL: +34-9375-24320 | FAX: +34-9375-24410 | Singapore | TEL: +65-6332-2322 | FAX: +65-6332-5662 |
| Hungary | TEL: +36-1-4719338 | FAX: +36-1-4719339 | Philippines | TEL: +63-2-807-6872 | FAX: +63-2-809-1422 |
| Poland | TEL: +48-22-5757213 | FAX: +48-22-5757001 | Thailand | TEL: +66-2-254-4890 | FAX: +66-2-256-6334 |
| Russia | TEL: +7-495-739-41-74 | FAX: +7-495-739-41-74 | Kuala Lumpur | TEL: +60-3-7958-8355 | FAX: +60-3-7958-8377 |
| Seoul | TEL: +82-2-8182-700 | FAX: +82-2-8182-715 | Penang | TEL: +60-4-2286453 | FAX: +60-4-2286452 |
| Masan | TEL: +82-55-240-6234 | FAX: +82-55-240-6236 | Kyoto | TEL: +81-75-365-1218 | FAX: +81-75-365-1228 |
| Dalian | TEL: +86-411-8230-8549 | FAX: +86-411-8230-8537 | Yokohama | TEL: +81-45-476-2290 | FAX: +81-45-476-2295 |
| Beijing | TEL: +86-10-8525-2483 | FAX: +86-10-8525-2489 | | | |

Excellence in Electronics



ROHM CO., LTD.

21 Saiin Mizosaki-cho, Ukyo-ku, Kyoto
615-8585, Japan
TEL: +81-75-311-2121 FAX: +81-75-315-0172
URL: <http://www.rohm.com>

Published by
KTC LSI Development Headquarters
LSI Business Promotion Group

Notice

Precaution on using ROHM Products

- Our Products are designed and manufactured for application in ordinary electronic equipments (such as AV equipment, OA equipment, telecommunication equipment, home electronic appliances, amusement equipment, etc.). If you intend to use our Products in devices requiring extremely high reliability (such as medical equipment ^(Note 1), transport equipment, traffic equipment, aircraft/spacecraft, nuclear power controllers, fuel controllers, car equipment including car accessories, safety devices, etc.) and whose malfunction or failure may cause loss of human life, bodily injury or serious damage to property ("Specific Applications"), please consult with the ROHM sales representative in advance. Unless otherwise agreed in writing by ROHM in advance, ROHM shall not be in any way responsible or liable for any damages, expenses or losses incurred by you or third parties arising from the use of any ROHM's Products for Specific Applications.

(Note1) Medical Equipment Classification of the Specific Applications

JAPAN	USA	EU	CHINA
CLASS III	CLASS III	CLASS II b	CLASS III
CLASS IV		CLASS III	

- ROHM designs and manufactures its Products subject to strict quality control system. However, semiconductor products can fail or malfunction at a certain rate. Please be sure to implement, at your own responsibilities, adequate safety measures including but not limited to fail-safe design against the physical injury, damage to any property, which a failure or malfunction of our Products may cause. The following are examples of safety measures:
 - Installation of protection circuits or other protective devices to improve system safety
 - Installation of redundant circuits to reduce the impact of single or multiple circuit failure
- Our Products are designed and manufactured for use under standard conditions and not under any special or extraordinary environments or conditions, as exemplified below. Accordingly, ROHM shall not be in any way responsible or liable for any damages, expenses or losses arising from the use of any ROHM's Products under any special or extraordinary environments or conditions. If you intend to use our Products under any special or extraordinary environments or conditions (as exemplified below), your independent verification and confirmation of product performance, reliability, etc. prior to use, must be necessary:
 - Use of our Products in any types of liquid, including water, oils, chemicals, and organic solvents
 - Use of our Products outdoors or in places where the Products are exposed to direct sunlight or dust
 - Use of our Products in places where the Products are exposed to sea wind or corrosive gases, including Cl₂, H₂S, NH₃, SO₂, and NO₂
 - Use of our Products in places where the Products are exposed to static electricity or electromagnetic waves
 - Use of our Products in proximity to heat-producing components, plastic cords, or other flammable items
 - Sealing or coating our Products with resin or other coating materials
 - Use of our Products without cleaning residue of flux (even if you use no-clean type fluxes, cleaning residue of flux is recommended); or Washing our Products by using water or water-soluble cleaning agents for cleaning residue after soldering
 - Use of the Products in places subject to dew condensation
- The Products are not subject to radiation-proof design.
- Please verify and confirm characteristics of the final or mounted products in using the Products.
- In particular, if a transient load (a large amount of load applied in a short period of time, such as pulse. is applied, confirmation of performance characteristics after on-board mounting is strongly recommended. Avoid applying power exceeding normal rated power; exceeding the power rating under steady-state loading condition may negatively affect product performance and reliability.
- De-rate Power Dissipation (Pd) depending on Ambient temperature (Ta). When used in sealed area, confirm the actual ambient temperature.
- Confirm that operation temperature is within the specified range described in the product specification.
- ROHM shall not be in any way responsible or liable for failure induced under deviant condition from what is defined in this document.

Precaution for Mounting / Circuit board design

- When a highly active halogenous (chlorine, bromine, etc.) flux is used, the residue of flux may negatively affect product performance and reliability.
- In principle, the reflow soldering method must be used; if flow soldering method is preferred, please consult with the ROHM representative in advance.

For details, please refer to ROHM Mounting specification

Precautions Regarding Application Examples and External Circuits

1. If change is made to the constant of an external circuit, please allow a sufficient margin considering variations of the characteristics of the Products and external components, including transient characteristics, as well as static characteristics.
2. You agree that application notes, reference designs, and associated data and information contained in this document are presented only as guidance for Products use. Therefore, in case you use such information, you are solely responsible for it and you must exercise your own independent verification and judgment in the use of such information contained in this document. ROHM shall not be in any way responsible or liable for any damages, expenses or losses incurred by you or third parties arising from the use of such information.

Precaution for Electrostatic

This Product is electrostatic sensitive product, which may be damaged due to electrostatic discharge. Please take proper caution in your manufacturing process and storage so that voltage exceeding the Products maximum rating will not be applied to Products. Please take special care under dry condition (e.g. Grounding of human body / equipment / solder iron, isolation from charged objects, setting of ionizer, friction prevention and temperature / humidity control).

Precaution for Storage / Transportation

1. Product performance and soldered connections may deteriorate if the Products are stored in the places where:
 - [a] the Products are exposed to sea winds or corrosive gases, including Cl₂, H₂S, NH₃, SO₂, and NO₂
 - [b] the temperature or humidity exceeds those recommended by ROHM
 - [c] the Products are exposed to direct sunshine or condensation
 - [d] the Products are exposed to high Electrostatic
2. Even under ROHM recommended storage condition, solderability of products out of recommended storage time period may be degraded. It is strongly recommended to confirm solderability before using Products of which storage time is exceeding the recommended storage time period.
3. Store / transport cartons in the correct direction, which is indicated on a carton with a symbol. Otherwise bent leads may occur due to excessive stress applied when dropping of a carton.
4. Use Products within the specified time after opening a humidity barrier bag. Baking is required before using Products of which storage time is exceeding the recommended storage time period.

Precaution for Product Label

QR code printed on ROHM Products label is for ROHM's internal use only.

Precaution for Disposition

When disposing Products please dispose them properly using an authorized industry waste company.

Precaution for Foreign Exchange and Foreign Trade act

Since our Products might fall under controlled goods prescribed by the applicable foreign exchange and foreign trade act, please consult with ROHM representative in case of export.

Precaution Regarding Intellectual Property Rights

1. All information and data including but not limited to application example contained in this document is for reference only. ROHM does not warrant that foregoing information or data will not infringe any intellectual property rights or any other rights of any third party regarding such information or data. ROHM shall not be in any way responsible or liable for infringement of any intellectual property rights or other damages arising from use of such information or data.:
2. No license, expressly or implied, is granted hereby under any intellectual property rights or other rights of ROHM or any third parties with respect to the information contained in this document.

Other Precaution



1. This document may not be reprinted or reproduced, in whole or in part, without prior written consent of ROHM.
2. The Products may not be disassembled, converted, modified, reproduced or otherwise changed without prior written consent of ROHM.
3. In no event shall you use in any way whatsoever the Products and the related technical information contained in the Products or this document for any military purposes, including but not limited to, the development of mass-destruction weapons.
4. The proper names of companies or products described in this document are trademarks or registered trademarks of ROHM, its affiliated companies or third parties.

General Precaution

1. Before you use our Products, you are requested to carefully read this document and fully understand its contents. ROHM shall not be in any way responsible or liable for failure, malfunction or accident arising from the use of any ROHM's Products against warning, caution or note contained in this document.
2. All information contained in this document is current as of the issuing date and subject to change without any prior notice. Before purchasing or using ROHM's Products, please confirm the latest information with a ROHM sales representative.
3. The information contained in this document is provided on an "as is" basis and ROHM does not warrant that all information contained in this document is accurate and/or error-free. ROHM shall not be in any way responsible or liable for any damages, expenses or losses incurred by you or third parties resulting from inaccuracy or errors of or concerning such information.

Looking for pricing, stock, or lifecycle information?

Click below to explore more details on WIN SOURCE:

-  [View BD9533EKN-E2 on WIN SOURCE](#)
-  [Rohm Semiconductor](#) Information

Optimize Your Supply Chain with WIN SOURCE Solutions

-  Global Sourcing Solution
-  Obsolete Management
-  Cost Control Management
-  Shortage Management
-  Alternative Solution
-  Excess Inventory Management