

Regulators ICs for Digital Cameras and Camcorders

Switching Regulator IC with Built-in FET (5V)

BD9757MWV

No.10036EAT09

●Description

BD9757MWV is an 8-channel switching regulator with a built-in FET for digital still camera. It has a built-in function to light-control the white LED for backlight according to the light control setting signal from microcomputer.

●Features

- 1) Starting from VBAT terminal of 1.5V
- 2) Power of internal circuit is supplied from voltage boost CH1
- 3) Mounted with a total of 8ch including voltage boost 2ch, voltage step-down 4ch, inversion 1ch, and white LED-purpose voltage boost (compatible with DC light control) 1ch
- 4) Built-in 5-channel transistors for synchronous rectification
- 5) Built-in 2-channel FET transistors for voltage boost
- 6) Built-in all-channel phase compensation between input and output of error amplifier
- 7) Channel 1 and 3 are common, but other channels are independent, so the ON/OFF is possible
- 8) Operating frequencies of 1.2MHz (CH1 ~ 5), 600KHz(CH6 ~ 8)
- 9) Built-in output breaking circuit (timer latch type) at the time of overload
- 10) Built-in 2ch of high side switch with soft start function
- 11) UQFN044V6060 package (6mm × 6mm ,0.4mm pitch) with heat dissipation

●Applications

Digital still camera

●Absolute maximum ratings (Ta=25°C)

Parameter	Symbol	Ratings	Units
Power Supply Voltage	VBAT	-0.3 ~ 7	V
Power Input Voltage	VHx1 ~ 5	-0.3 ~ 7	V
	HS78H	-0.3 ~ 7	V
	VLx7,8	-0.3 ~ 22	V
Maximum output current	IomaxLx1	±2.5	A
	IomaxHx1	±1.5	A
	IomaxHx2,5	+1.0	A
	IomaxHx3,4	+0.8	A
	IomaxHS78	+1.2	A
	IomaxLx7,8	±1.0	A
Power Dissipation	Pd	0.54 ^(※1)	W
Operating temperature range	Topr	-25 ~ +85	°C
Storage temperature range	Tstg	-55 ~ +150	°C
Junction temperature	Tjmax	+150	°C

※1 At the time of a single IC. If used in more than Ta=25°C, reduced by 4.32mW/°C.

●Operating conditions

Parameter	Symbol	Ratings			Unit	conditions
		Min.	Typ.	Max.		
Power supply voltage	VBAT	1.5	-	5.5	V	
VREF terminal connection capacity	CVREF	0.47	1.0	4.7	μF	
VREGA terminal connection capacity	CVREGA	0.47	1.0	4.7	μF	
【CH8 modulated light】						
H fixed time when the modulated light control setting is determined	T _{ON}	265X 1/fosc1	-	-	sec	
L fixed time when OFF	T _{OFF}	256X 1/fosc1	-	-	sec	
H fixed time at the time of modulated light control setting	T _H	500	-	10000	nsec	
L fixed time at the time of modulated light control setting	T _L	500	-	10000	nsec	
H fixed time at the time of EN starting up	T _{EN}	4X 1/fosc1	-	-	sec	
L fixed time before modulated light control setting	T _{CLR}	7X 1/fosc1	-	255X 1/fosc1	sec	
Time of light control setting at the time of starting up	T _{SET}	-	-	2048X 1/fosc1	sec	
【Driver】						
CH1 PMOS drain current	Idp1	-	-	1.2	A	
CH1 NMOS drain current	Idn1	-	-	2.3	A	
CH2,5 PMOS drain current	Idp2	-	-	0.8	A	
CH2, 5 NMOS drain current	Idn2	-	-	0.8	A	
CH3, 4 PMOS drain current	Idp22	-	-	0.6	A	
CH3, 4 NMOS drain current	Idn22	-	-	0.6	A	
CH6 driver output peak current	Idpeak	-	-	±0.5	A	
CH7, 8 high side switch input current	Idp17,8	-	-	1.0	A	
CH7, 8 NMOS drain current	Idn16	-	-	0.8	A	
【Output voltage setting range】						
CH1	-	4.5	-	5.4	V	
CH2	-	1.0	-	4.4	V	
CH3	-	1.0	-	4.4	V	
CH4	-	1.0	-	4.4	V	
CH5	-	1.0	-	4.4	V	
CH6	-	-8.0	-	-5.0	V	
CH7	-	8.5	-	16	V	
CH8	-	8.5	-	20	V	

● **Electrical characteristics** (Unless specified, Ta=25°C, VCCOUT=5.0V, VBAT=3V, STB13 ~ 7=3V, UPIC8=2.5V)

Parameter	Symbol	Limits			Unit	Conditions
		Min.	Typ.	Max.		
【Internal regulator VREGA】						
Output voltage	VREGA	2.4	2.5	2.6	V	Io=5mA
【Low-voltage input malfunction prevention circuit】						
Detecting voltage 1	Vstd1	-	2.0	2.3	V	VREGA monitor
Hysteresis width 1	Δ Vstd1	50	100	200	mV	
Detecting voltage 2	Vstd2	-	2.4	2.5	V	VCCOUT monitor
Hysteresis width 2	Δ Vstd2	100	200	300	mV	
【Short-circuit protection circuit】						
SCP detecting time	Tscp	20	25	30	msec	
Timer start threshold voltage	Vtcinv	0.38	0.48	0.58	V	INV terminal monitor CH3 ~ 5
【Start circuit】						
Oscillating frequency	Fstart	150	300	600	kHz	
Operation initiation VBAT voltage	Vst1	1.5	-	-	V	
Start-up CH soft start time	Tss1	1.8	3.0	5.3	msec	
【Oscillating circuit】						
Oscillating frequency CH1 ~ 5	fosc1	1.0	1.2	1.4	MHz	
Oscillating frequency CH6 ~ 8	fosc2	0.5	0.6	0.7	MHz	
Max duty 2,3,4,5(voltage step-down)	Dmax1d	-	-	100	%	(※2)
Max duty 1(voltage boost)	Dmax1u	86	92	96	%	
Max duty 6,7,8	Dmax2	86	92	96	%	
【Error AMP】						
Input bias current	IINV	-	0	50	nA	INV1 ~ 8, NON5=3.0V
INV threshold 1	VINV1	0.79	0.80	0.81	V	CH1 ~ 5
INV threshold 2	VINV2	0.99	1.00	1.01	V	CH7,8V
INV threshold 3 (max)	VINV3	370	400	430	mV	CH8I
【Base Bias Voltage Vref for inverted Channel】						
CH6 output voltage	VOUT6	-6.09	-6.00	-5.91	V	NON6 12k Ω , 72k Ω (※3)
Line regulation	DVLI	-	4.0	12.5	mV	VCCOUT=1.5 ~ 5.5V
Output circuit at the time of short-circuit	Ios	0.2	1.0	-	mA	Vref=0V
【Soft start】						
CH2, 5 soft start time	Tss2, 5	3.4	4.4	5.4	msec	
CH3, 4 soft start time	Tss3, 4	1.2	2.2	3.2	msec	
CH6 soft start time	Tss6	3.4	4.4	5.4	msec	
CH7, 8 soft start time	Tss7, 8	4.4	5.4	6.6	msec	

※2 The protective circuit start working when circuit is operated by 100% duty.

So it is possible to use only for transition time shorter than charge time for SCP.

※3 Recommend resistor value over 20k Ω between VREF to NON6, because VREF current is under 100 μ A.

© This product is not designed for normal operation within a radioactive environment.

●Electrical characteristics (Unless specified, Ta=25°C, VCCOUT=5.0V, VBAT=3V, STB13 ~ 7=3V,UPIC8=2.5V)

Parameter	Symbol	Limits			Unit	Conditions	
		Min.	Typ.	Max.			
【Output Driver】							
CH1 High side switch ON resistance	RON1p	-	120	270	mΩ	Hx1=5V	
CH1 Low side switch ON resistance	RON1N	-	80	240	mΩ	VCCOUT=5.0V	
CH2 High side switch ON resistance	RON21p	-	250	400	mΩ	Hx2=5V	
CH2 Low side switch ON resistance	RON21N	-	250	400	mΩ	VCCOUT=5.0V	
CH3 High side switch ON resistance	RON3p	-	250	400	mΩ	Hx3=3V , VCCOUT=5V	
CH3 Low side switch ON resistance	RON3N	-	250	400	mΩ	VCCOUT=5.0V	
CH4 High side switch ON resistance	RON4p	-	250	400	mΩ	Hx4=3V, VCCOUT=5V	
CH4 Low side switch ON resistance	RON4N	-	250	400	mΩ	VCCOUT=5.0V	
CH5 High side switch ON resistance	RON5p	-	250	400	mΩ	Hx5=5V	
CH5 Low side switch ON resistance	RON5N	-	150	300	mΩ	VCCOUT=5.0V	
Output voltage H at the time of CH6 driving	Vout6H	VCCOUT -1.5	VCCOUT -1.0	-	V	IOUT6=50mA NON6=0.2V	
Output voltage L at the time of CH6 driving	Vout6L	-	0.5	1.0	V	IOUT6=-50mA, NON6=-0.2V	
CH7,8 NMOS switch ON resistance	RON7,8N	-	500	800	mΩ	VCCOUT=5.0V	
CH7,8 load switch ON resistance	RON7,8p	-	200	350	mΩ	HS7,8H=3V , VCCOUT=5.0V	
【STB1 ~ 7】							
STB control voltage	operating	VSTBH1	1.5	-	5.5	V	
	Non-operating	VSTBL1	-0.3	-	0.3	V	
Pull down resistance		RSTB1	250	400	700	kΩ	
【UPIC8】							
UPIC8 Control voltage	H level	VUPIH	2.1	-	4.00	V	
	L level	VUPI L	0	-	0.40	V	
Pull down resistance		RUPIC1	30	50	80	kΩ	
【Circuit current】							
Circuit current at the time of standby	VBAT terminal	ISTB1	-	-	5	μA	
	HS7,8H terminal	ISTB4	-	-	5	μA	
	Hx terminal	ISTB2	-	-	5	μA	Voltage step-down
	Lx terminal	ISTB3	-	-	5	μA	Voltage boost
Circuit current at the time of Start-up (VBAT terminal inflow current)		IST	-	150	450	μA	VBAT=1.5V
Circuit current 1 at the time of operating (VBAT terminal inflow current)		Icc1	-	45	150	μA	VBAT=3.0V
Circuit current 2 at the time of operating (VCCOUT applied terminal inflow current)		Icc2	-	5.0	9.7	mA	INV1 ~ 8=1.2V , NON6=-0.2V

© This product is not designed for normal operation within a radioactive environment.

●Reference data (1)

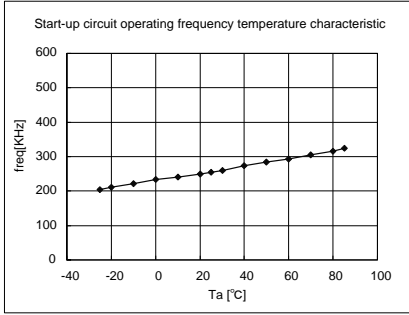

Fig.1 Start-up circuit frequency-Temp

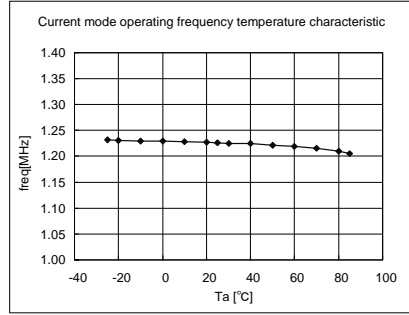

Fig.2 Frequency CH1 ~ 5-Temp

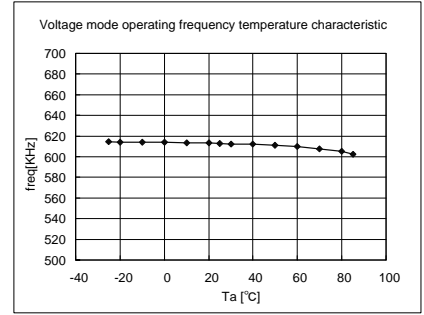

Fig.3 Frequency CH6 ~ 8-Temp

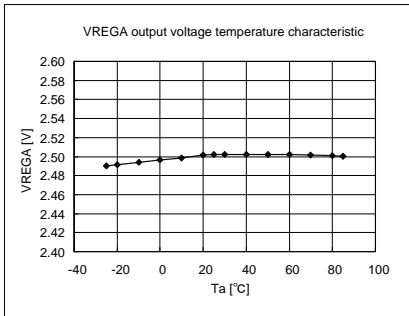

Fig.4 VREGA output voltage-Temp

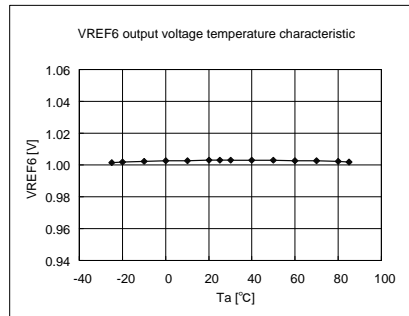

Fig.5 CH6 Base voltage-Temp

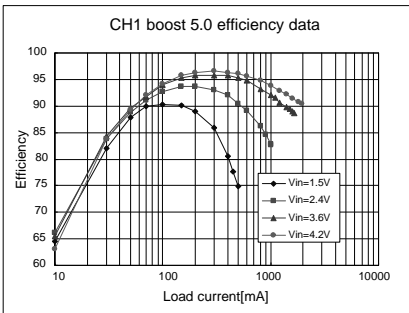

Fig.6 CH1 5.0V voltage boost efficiency-lo

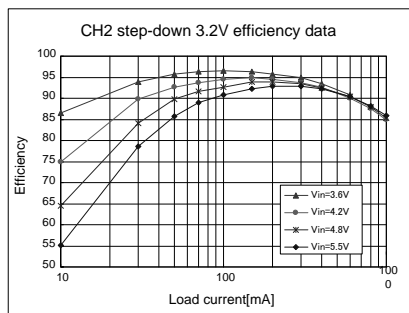

Fig.7 CH2 3.2V step-down efficiency-lo

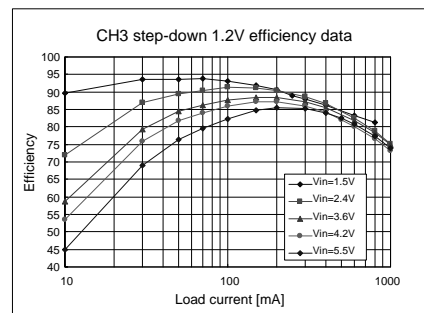

Fig.8 CH2 3.2V step-down efficiency-lo

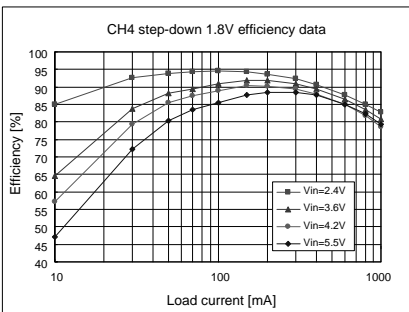

Fig.9 CH4 1.8V step-down efficiency-lo

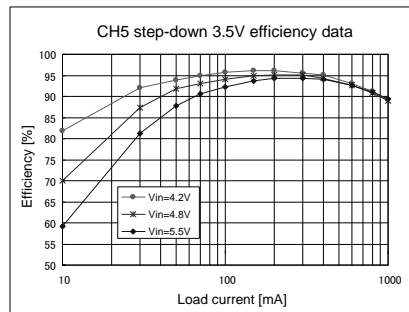

Fig.10 CH5 3.5V step-down efficiency-lo

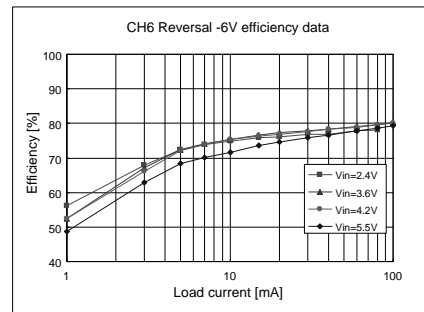

Fig.11 CH6 -6V inverting efficiency-lo

●Reference data (2)

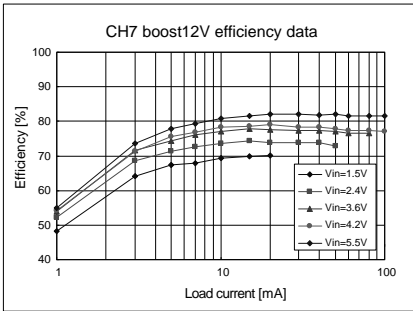

Fig.12 CH7 12V boost efficiency-lo

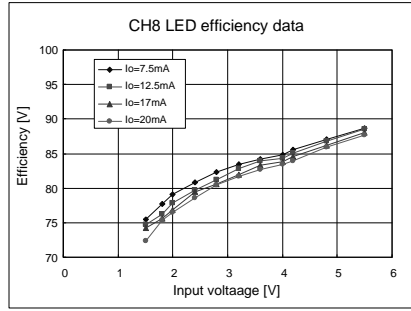

Fig.13 CH8 LED boost efficiency-lo

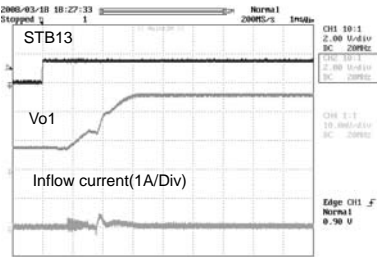

Fig.14 CH1 start-up waveform (VBAT=1.5V)

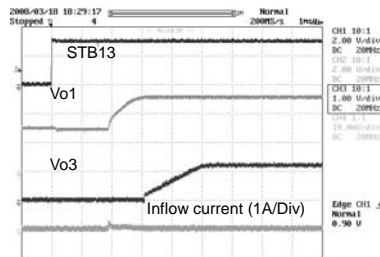

Fig.15 CH1,3 start-up waveform (VBAT=3.0V)

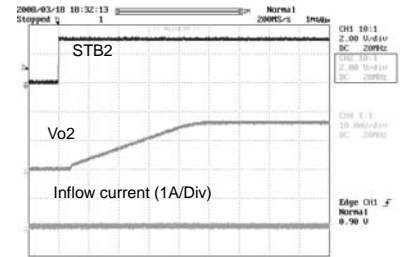

Fig.16 CH2 start-up waveform

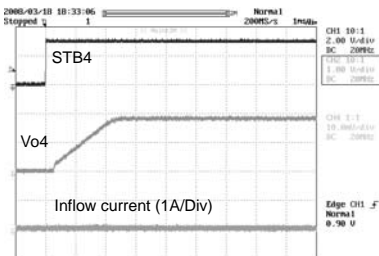

Fig.17 CH4 start-up waveform

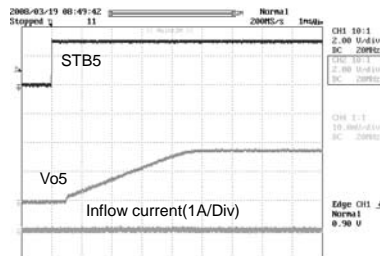

Fig.18 CH5 start-up waveform

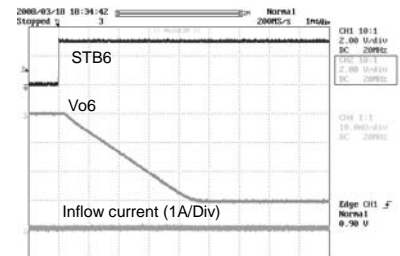

Fig.19 CH6 start-up waveform

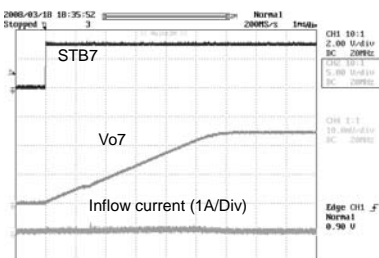

Fig.20 CH7 start-up waveform

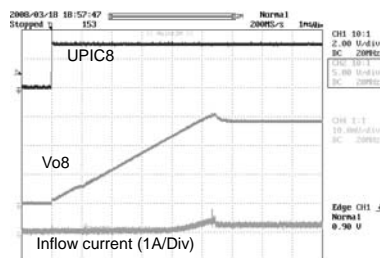

Fig.21 CH8 start-up waveform

● Pin Assignment

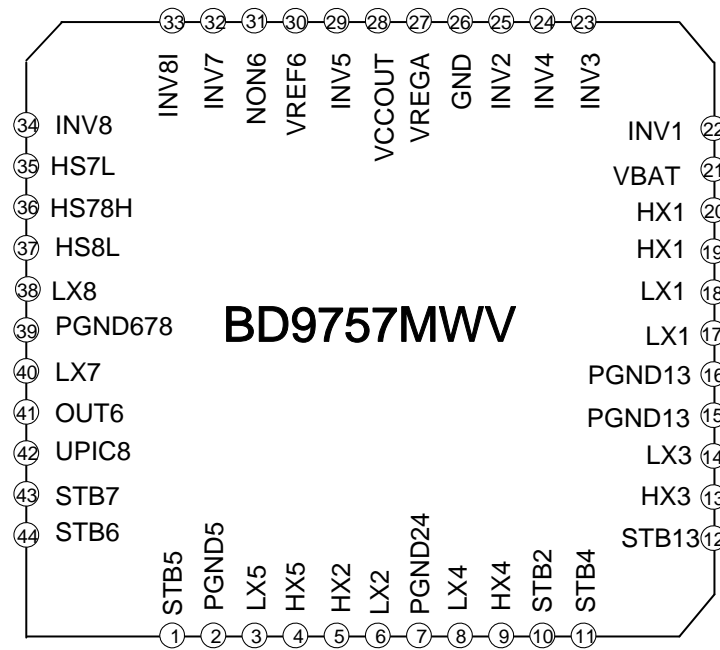

Fig.22 BD9757MWV Top VIEW

● Pin Description

PIN No.	PIN name	I/O	Function	Notes
21	VBAT	I	Battery voltage input	Starting up at higher than 1.5V
28	VCCOUT	I	Power supply input terminal	Connecting the CH1 output
26	GND	-	Earth terminal	
15,16,7,2,39	PGND13,24,5, 678	-	Earth terminal with built-in FET	
27	VREGA	O	VREGA output	2.5V output
30	VREF6	O	reference voltage output for CH6 inversion	1.0V output
41	OUT6	O	CH6 PMOS gate connection terminal	
19,20,5,13,9,4	Hx1,2,3,4,5	O	Synchronous rectification high side switch input terminal, Pch Driver power supply output	
17,18,6,14,8,3,40,38	Lx1,,2,3,4,5,7,8	O	Inductor connection terminal	
36	HS78H	I	Built-in load switch power supply input terminal	
35,37	HS7L,HS8L	O	Built-in load switch output terminal	
22,25,23,24,29,32,34	INV1,2,3,4,5,7,8	I	Error amplifier inversion input terminal	
31	NON6	I	Error amplifier non-inversion input terminal	
33	INV8I	I	Error amplifier inversion input terminal	
12,10,11,1,44,43	STB13,2,4,5,6,7	I	CH1 ~ CH7 ON / OFF switch Operating :higher than 1.5V	At the time of All Low Standby state
42	UPIC8	I	CH8 start-up signal, LED light control-purpose signal input	

●Application circuit (1)

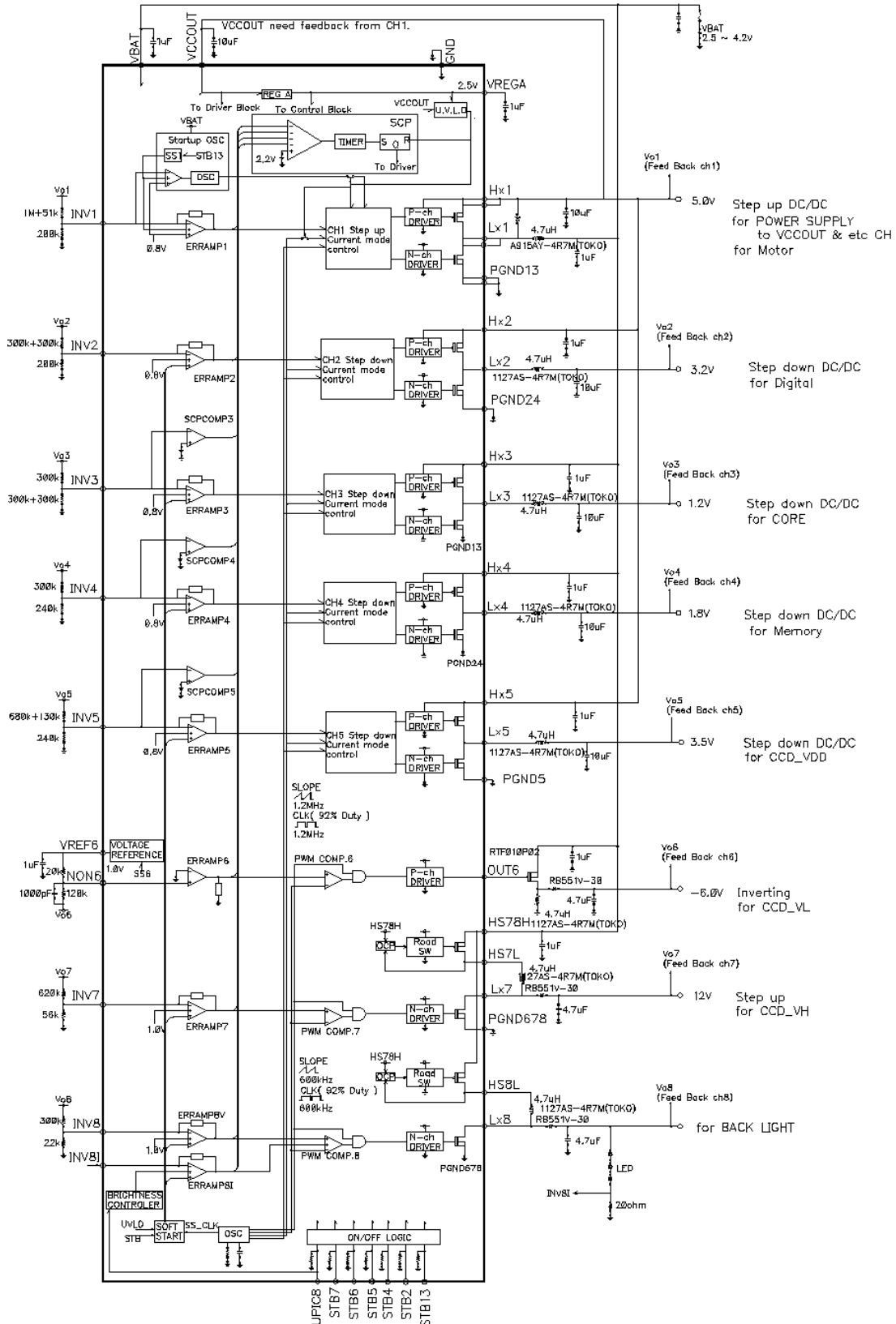

Fig.23 Applied circuit diagram 1(lithium 1 cell)

Operation notes

- we are confident that the above applied circuit diagram should be recommended, but please thoroughly confirm its characteristics when using it. In addition, when using it with the external circuit's constant changed, please make a decision that allows a sufficient margin in light of the fluctuations of external components and ROHM's IC in terms of not only static characteristic but also transient characteristic.

●Application circuit (2)

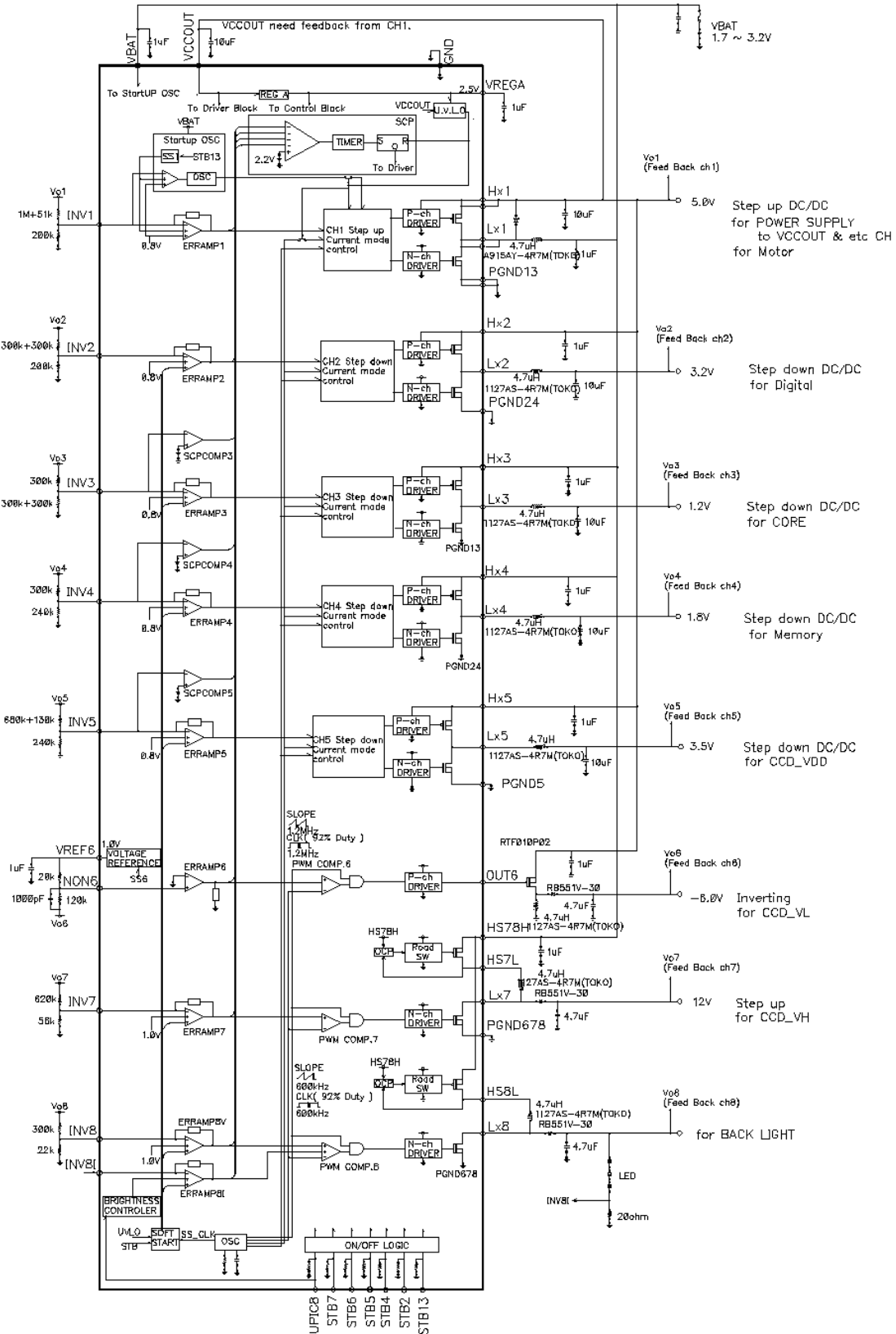

Fig.24 Applied circuit diagram 2(dry battery x2)

Operation notes

- we are confident that the above applied circuit diagram should be recommended, but please thoroughly confirm its characteristics when using it. In addition, when using it with the external circuit's constant changed, please make a decision that allows a sufficient margin in light of the fluctuations of external components and ROHM's IC in terms of not only static characteristic but also transient characteristic.

●Timing chart (1)

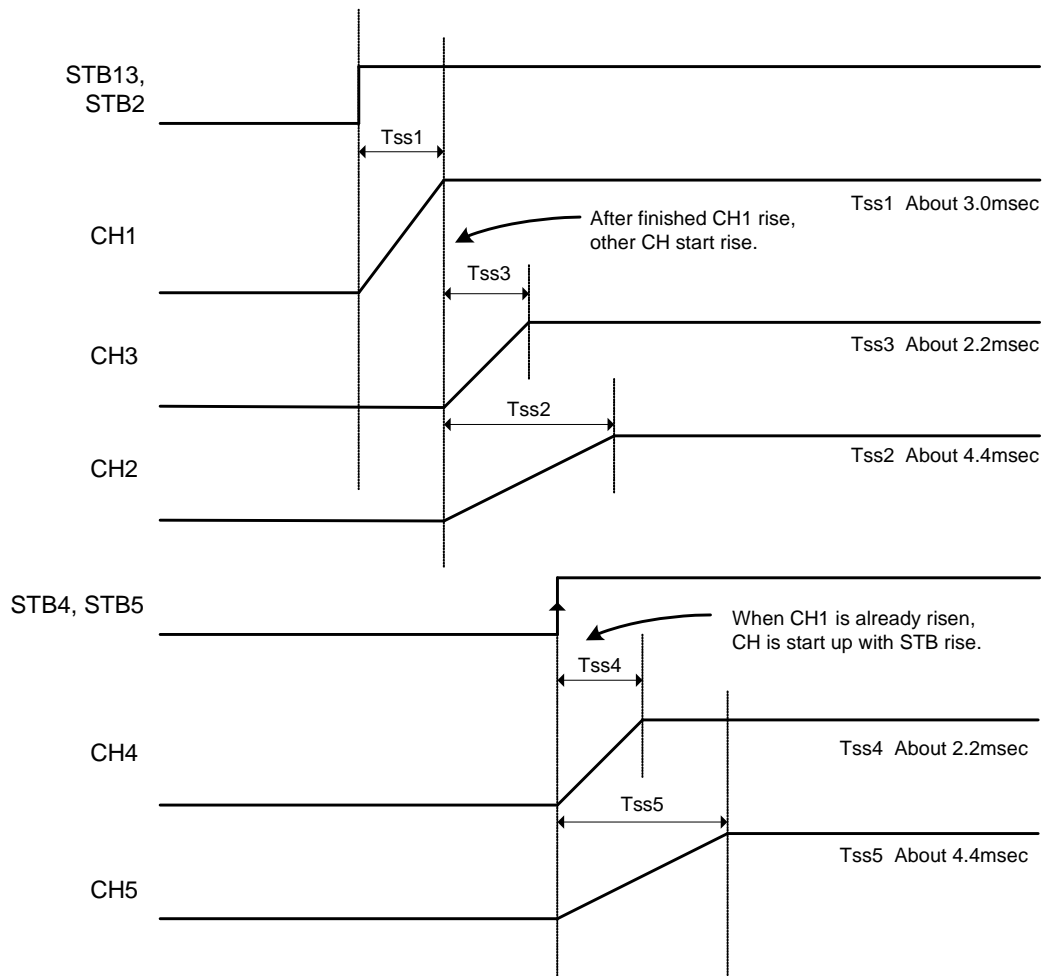

Fig.25 CH1 ~ 5 start-up sequence

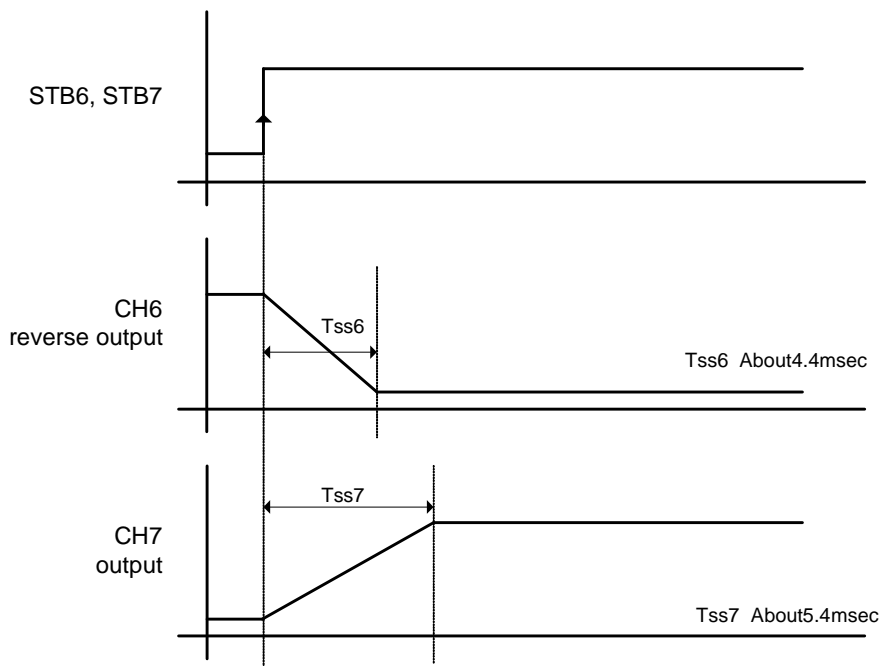

Fig.26 CH6, 7 start-up sequence

●Timing chart (2)

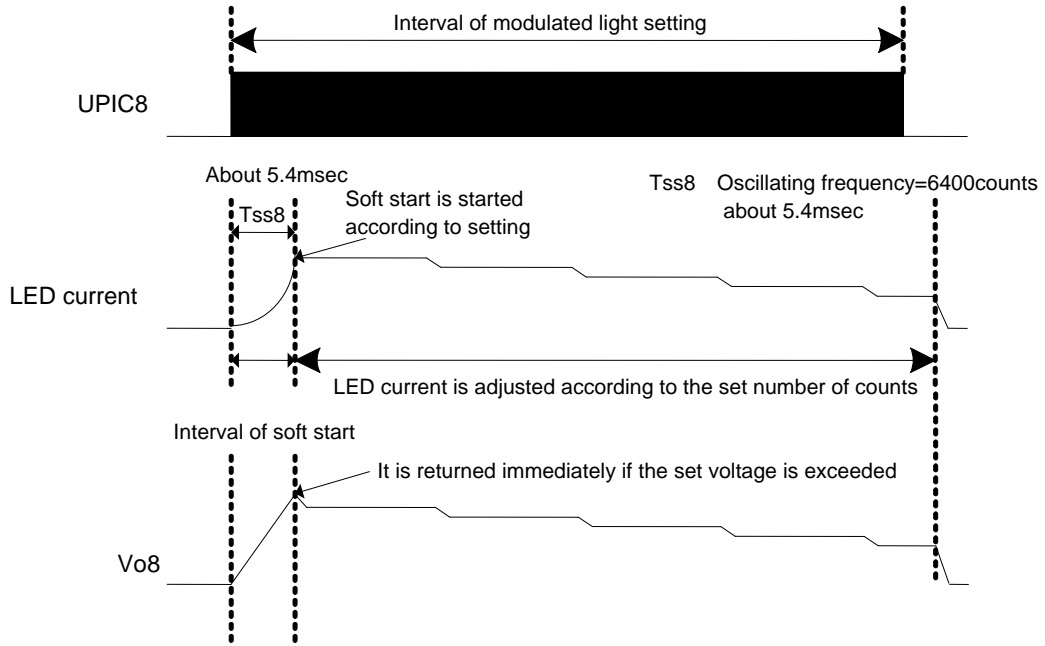

Fig.27 CH8 start-up sequence

●Block explanation

1. VREGA
It is a regulator with output voltage of 2.5V and used as a power supply of internal block. In addition, it outputs to outside from VREGA terminal (32pin). 1.0μF is recommended as an external capacitor for oscillation prevention.
2. SCP, Timer Latch
It is a timer latch type of short-circuit protection circuit.
For CH1,2, 6 ~ 8, the error AMP output voltage is monitored, and detected when the feedback voltage deviates from control, for CH3 ~ 5, it is detected when the voltage of INV terminal becomes lower than 80%, and in 25ms the latch circuit operates and the outputs of all the channels are fixed at OFF.
In order to reset the latch circuit, please turn off all the STB terminals before turning them on once again or turning power supply on once again.
3. U.V.L.O (Under Voltage Lockout)
It is a circuit to prevent malfunction at low voltage.
It is to prevent malfunction of internal circuit at the time of rising or dropping to a lower value of power supply voltage.
If the voltage of VCCOUT terminal becomes lower than 2.4V, then the output of each DC/DC converter is reset to OFF, and SCP's timer latch & soft start circuit are reset. When control is deviated from, the operation of CH1 at the time of start-up will be explained in START UP OSC mentioned later.
4. Voltage Reference (VREF6)
For the reference voltage circuit of CH6 inversion CH, the output voltage is 1V and outputted from VREF6 terminal (30pin). According this voltage and the output voltage of CH6, the dividing resistance (resistor) is set and then the output voltage is set. If STB6 terminal is made to be H level at the time of start-up, then increase gradually the voltage up to 1V. The inversion output of CH6 follows this voltage and performs the soft start. 1.0μF is recommended as the external capacitor.
5. OSC
It is an oscillation circuit the frequency of which is fixed by a built-in CR.
The operating frequencies of CH1 ~ CH5 are set at 1.2MHz, and the operating frequencies of CH6 ~ CH8 are set at 600kHz.
6. ERRAMP 1 ~ 8
It is an error amplifier to detect output signal and output PWM control signal. The reference voltages of ERRAMP (Error Amplifier) of CH1, 2,3,4,5 are internally set at 0.8V, and the reference voltages of ERRAMP (Error Amplifier) of CH7,8 are set at 1.0V. The reference voltage of CH6 is set at GND potential, and for CH8's ERRAMP81, the maximum value of the reference voltage is set at 0.4V. In addition, each CH incorporates a built-in element for phase compensation.
7. ERRCOMP , Start Up OSC
It is a comparator to detect the output voltage and control the start circuit, and also an oscillator that is turned ON/OFF by this comparator and starts operating from 1.5V. The frequency of this oscillator is about 300 kHz fixed internally. This oscillator stops operating if VCC terminal becomes more than 2.6V or the soft start time is exceeded.
8. Current mode control block
CH1 ~ 5 adopt the PWM method based on current mode.
For a current- mode DC/DC converter, FET at the main side of synchronous rectification is turned on when detecting the CLK's edge, and turned off by detecting the peak current by means of the current comparator.
9. PWM COMP
PWM converter is a voltage-pulse width converter to control output voltage according to input voltage. It compares the output voltage of error amplifier with the SLOPE waveform, controls the pulse width and outputs to driver. The driver is turned on during the output of error amplifier being higher than SLOPE waveform. The maximum ON duty is set at about 92% internally.

10. Nch DRIVER , Pch DRIVER

It is a CMOS inverter type of output circuit to drive both built-in and external Nch,Pch FET.

11. Load switch

It is a circuit, mounted in CH7, 8, to control the Load switch. HS78H terminal (36pin) is input terminal, and the HS67 and HS78 terminals (40,37pin) are output terminals.

This control circuit can prevent the rush current at the time of switch ON because the soft start starts functioning at the time of start-up. In addition, this Load switch is provided with OCP function to prevent the IC from damage.

Ensure that the IC is used within Load switch's rated current when used normally.

12. ON/OFF LOGIC

It is the voltage applied to STB terminal and can control the ON/OFF of CH1 ~ CH7.

If the voltage more than 1.5V is applied, then it becomes ON, but if open or 0V is applied, then it becomes off, furthermore, if all the channels are turned off, then the whole IC will be in standby state. In addition, STB13 ~ STB7 terminals contain respectively a built-in pull-down resistor of about 400kΩ. UPIC8 is the input terminal of the start signal and the light control signal of CH8. It becomes High if the voltage more than 2.1V is applied and becomes Low if the voltage less than 0.4V is applied. In addition, UPIC8 terminal contains a built-in pull-down resistor of about 50kΩ.

13. SOFT START

It is a circuit to apply the soft start to the output voltage of DC/DC converter and prevent the rush current at the start-up. Soft start time varies with the channels.

- a. CH1 · · · · · Reaches the target voltage in 3.0 msec.
- b. CH3,4 · · · · · Reaches the target voltage in 2.2 msec.
- c. CH2,5,6 · · · · · Reaches the target voltage in 4.4 msec.
- d. CH7,8 · · · · · Reaches the target voltage in 5.4 msec.

UPIC8 rising edge count	DAC input DACIN[4:0]	INV8I output voltage [V]
1	01h	0.100
2	02h	0.110
3	03h	0.120
4	04h	0.130
5	05h	0.140
6	06h	0.150
7	07h	0.160
8	08h	0.170
9	09h	0.180
10	0Ah	0.190
11	0Bh	0.200
12	0Ch	0.210
13	0Dh	0.220
14	0Eh	0.230
15	0Fh	0.240
16	10h	0.250
17	11h	0.260
18	12h	0.270
19	13h	0.280
20	14h	0.290
21	15h	0.300
22	16h	0.310
23	17h	0.320
24	18h	0.330
25	19h	0.340
26	1Ah	0.350
27	1Bh	0.360
28	1Ch	0.370
29	1Dh	0.380
30	1Eh	0.390
31	1Fh	0.400

Fig.30 LED current setting

(Note 1) LED current = INV8I voltage / resistance R for LED current setting

●Setting method of IC peripheral components

(1) Design of feedback resistor constant

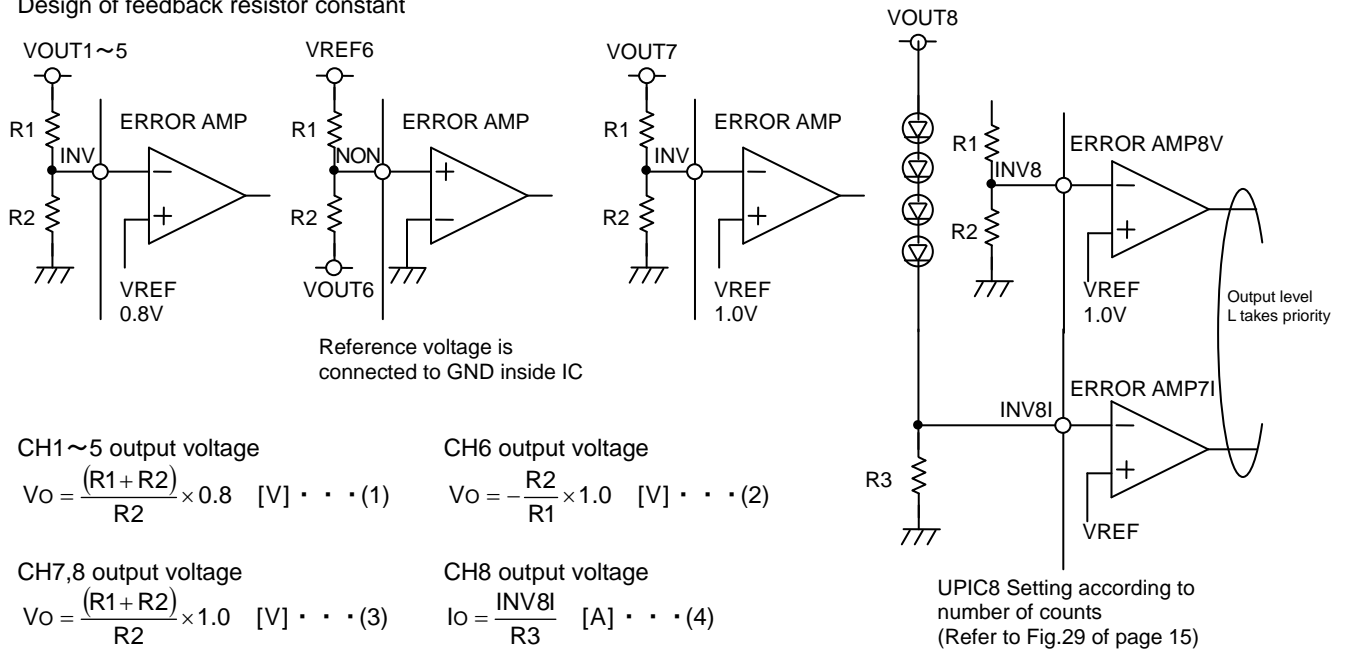

Fig.31 Feedback resistor setting method

(a) CH1 ~ 5 setting

The reference voltage of CH1 ~ 5's ERROR AMP is 0.8V. Please refer to Formula (1) in Fig.31 for determining the output voltage.

This IC incorporates built-in phase compensation. Please refer to Applied Circuit Diagram for setting the values of R1 & R2 and ensure that the setting values of R1 & R2 are of the order of several hundred kΩ.

(b) CH6 setting

The reference voltage of CH6's ERROR AMP is connected to GND inside the IC. Therefore, a high-accuracy regulator can be configured if setting by the feedback resistance between the outputs of VREF and CH5 as shown in Fig.31. Please refer to Formula (2) in Fig.31 for determining the output voltage. R1 is recommended as more than 20kΩ because the current capacity of VREF is about 100μA.

(c) CH7 setting

The reference voltage of CH7's ERROR AMP is 1.0V. Please refer to Formula (3) in Fig.31 for determining the output voltage.

(d) CH8 setting

In the CH8 there are two ERROR AMPs which have different standards, and when used with constant current feedback applied unilaterally to backlight etc., the over voltage protection can be operated unilaterally.

Over voltage setting and output current setting are respectively shown in Formula (3) and (4) in Fig.31.

The outputs of these two ERROR AMPs are controlled with L being given priority.

Therefore, when used under the control of only either of the two ensure that the INV terminal is used as GND Short.

CH6, CH7, and CH8 are of voltage mode control. Ensure that CH6, 7 and 8 are used by means of discontinuous inductor current so as to secure the oscillation margin.

(2) Points for attention in terms of PCB layout of base-plate

○For a switching regulator, in principle a large current transiently flows through the route of power supply - coil - output capacitor. Ensure that the wiring impedance is lowered as much as possible by making the pattern as wide as possible and the layout as short as possible.

○Interference of power supply noise with feedback terminals (INV1 ~ 8, NON6) may cause the output voltage to oscillate. Ensure that the power supply noise's interference is avoided by making the wiring between feedback resistor and feedback terminal as short as possible.

●PIN equivalent circuit

INV1~INV8,INV8I
(Error amplifier's inversion input)

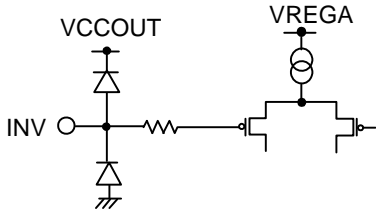

NON6
(Error amplifier's non-inversion input)

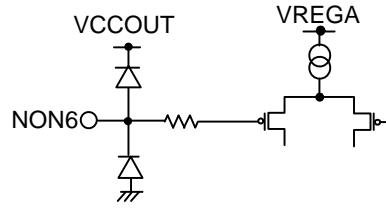

VREGA (REGA output)

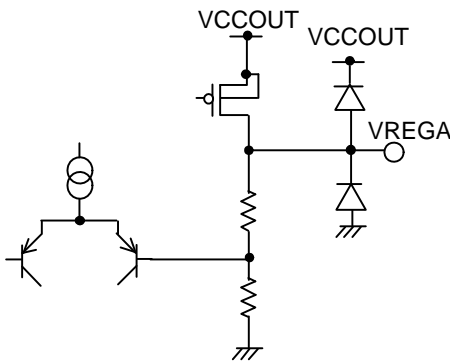

VREF6
(CH6 Standard voltage output)

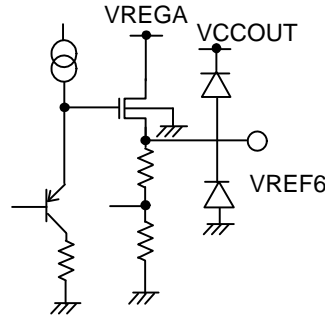

STB13, STB2, STB4, STB5,
STB6, STB7 (Operating when
CH1~7 ON/OFF switch is High)

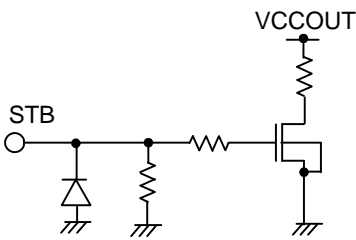

UPIC8
(CH8 start signal, LED
modulated light signal input)

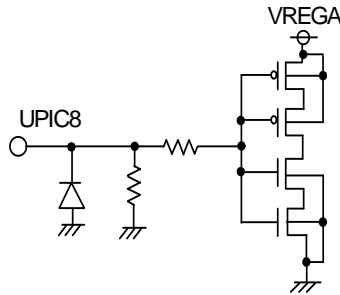

Hx1,2,3,4,5(Pch FET source terminal)
Lx1,2,3,4,5(Nch,Pch FET drain terminal)
PGND13,24,5 (output stage earthing terminal)

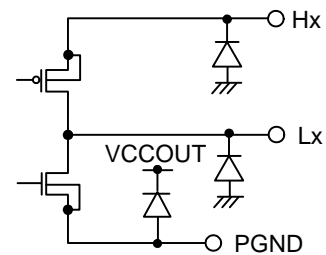

HS78H (high side SW input terminal)
HS7L, 8L (high side SW output terminal)

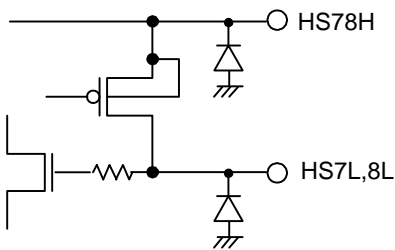

OUT5(CH5 power-MOSFET connection)
PGND567 (output stage earthing)

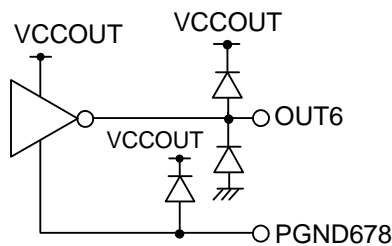

Lx7, 8 (Nch FET drain terminal)
PGND678

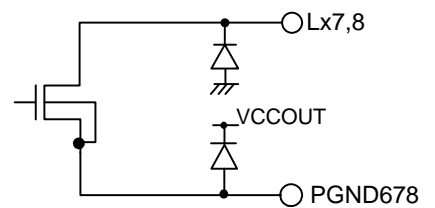

Fig.32 PIN equivalent circuit

●Notes for use

- 1.) Absolute Maximum Ratings
Although the quality of this product has been tightly controlled, deterioration or even destruction may occur if the absolute maximum ratings, such as for applied pressure and operational temperature range, are exceeded. Furthermore, we are unable to assume short or open mode destruction conditions. If special modes which exceed the absolute maximum ratings are expected, physical safety precautions such as fuses should be considered.
- 2.) GND Potential
The potential of the GND pin should be at the minimum potential during all operation status. In addition, please try to do not become electric potential below GND for the terminal other than NON6 including the transient phenomenon in practice. Please do not go down below 0.3V for the NON6 terminal with transient phenomenon and the like when you use.
- 3.) Heat Design
Heat design should consider tolerance dissipation (Pd) during actual use and margins which should be set with plenty of room.
- 4.) Short-circuiting Between Terminals and Incorrect Mounting
When attaching to the printed substrate, pay special attention to the direction and proper placement of the IC. If the IC is attached incorrectly, it may be destroyed. Destruction can also occur when there is a short, which can be caused by foreign objects entering between outputs or an output and the power GND.
- 5.) Operation in Strong Magnetic Fields
Exercise caution when operating in strong magnet fields, as errors can occur.
- 6.) About common impedance
Please do sufficient consideration for the wiring of power source and GND with the measures such as lowering common impedance, making ripple as small as possible (making the wiring as thick and short as possible, dropping ripple from L.C) and the like.
- 7.) STB terminal voltage
Please set STB terminal voltage below 0.3V when each channel is put in stand-by state, and set it above 1.5V when each channel is put in working condition. Please use the condenser below 0.01 μ F when the condenser is connected to the STB terminal. As it will become the cause of the malfunction.
- 8.) Heat Protection Circuit (TSD circuit)
This IC has a built-in Temperature Protection Circuit (TSD circuit). The temperature protection circuit (TSD circuit) is only to cut off the IC from thermal runaway, and has not been designed to protect or guarantee the IC. Therefore, the user should not plan to activate this circuit with continued operation in mind.
- 9.) Because there are times when rush current flows instantaneously in internal logical uncertain state at the time of power source turning on with CMOS IC, please pay attention to the power source coupling capacity, the width of GND pattern wiring and power source, and the reel.
- 10.) Because there are times when rush current flows instantaneously due to the order of power source throwing in, lag with CMOS IC where it has plural power sources, please pay attention to the power source coupling capacity, the width of GND pattern wiring and power source, and the reel.
- 11.) IC Terminal Input
This IC is a monolithic IC, and between each element there is a P+ isolation and P substrate for element separation. There is a P-N junction formed between this P-layer and each element's N-layer, which makes up various parasitic elements. For example, when resistance and transistor are connected with a terminal as in Fig.33:
 - When GND > (terminal A) at the resistance, or GND > (terminal B) at the transistor (NPN), the P-N junction operates as a parasitic diode.
 - Also, when GND > (terminal B) at the transistor, a parasitic NPN transistor operates by the N-layer of other elements close to the aforementioned parasitic diode.
 With the IC's configuration, the production of parasitic elements by the relationships of the electrical potentials is inevitable. The operation of the parasitic elements can also interfere with the circuit operation, leading to malfunction and even destruction. Therefore, uses which cause the parasitic elements to operate, such as applying voltage to the input terminal which is lower than the GND (P-substrate), should be avoided.

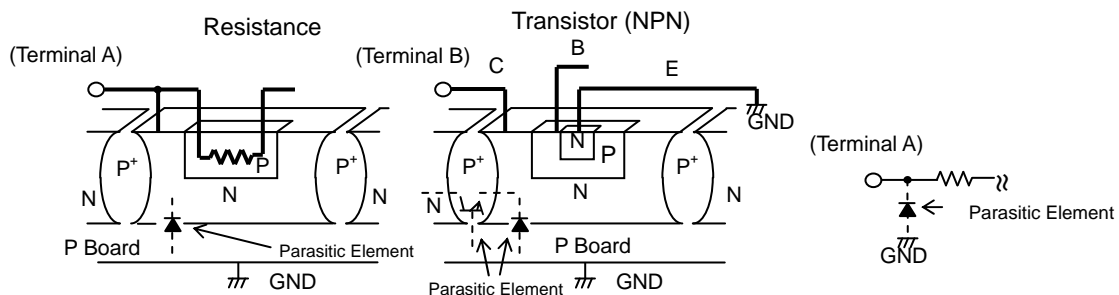

Fig.33 Simple Structure of Bipolar IC (Sample)

●Ordering part number

B	D
---	---

Part No.

9	7	5	7
---	---	---	---

Part No.

M	W	V
---	---	---

Package
MWV: UQFN044V6060

E	2
---	---

Packaging and forming specification
E2: Embossed tape and reel

UQFN044V6060

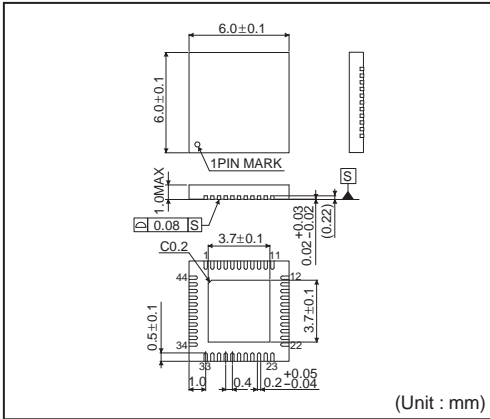

<Tape and Reel information>

Tape	Embossed carrier tape
Quantity	2000pcs
Direction of feed	E2 (The direction is the 1pin of product is at the upper left when you hold reel on the left hand and you pull out the tape on the right hand)

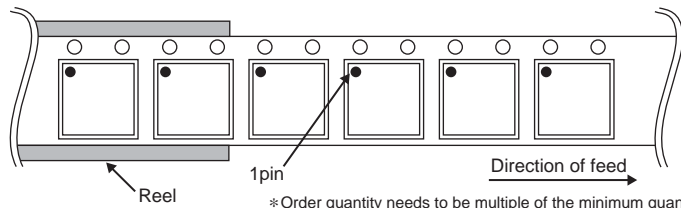

Notice

Precaution on using ROHM Products

- Our Products are designed and manufactured for application in ordinary electronic equipments (such as AV equipment, OA equipment, telecommunication equipment, home electronic appliances, amusement equipment, etc.). If you intend to use our Products in devices requiring extremely high reliability (such as medical equipment ^(Note 1), transport equipment, traffic equipment, aircraft/spacecraft, nuclear power controllers, fuel controllers, car equipment including car accessories, safety devices, etc.) and whose malfunction or failure may cause loss of human life, bodily injury or serious damage to property ("Specific Applications"), please consult with the ROHM sales representative in advance. Unless otherwise agreed in writing by ROHM in advance, ROHM shall not be in any way responsible or liable for any damages, expenses or losses incurred by you or third parties arising from the use of any ROHM's Products for Specific Applications.

(Note1) Medical Equipment Classification of the Specific Applications

JAPAN	USA	EU	CHINA
CLASS III	CLASS III	CLASS II b	CLASS III
CLASS IV		CLASS III	

- ROHM designs and manufactures its Products subject to strict quality control system. However, semiconductor products can fail or malfunction at a certain rate. Please be sure to implement, at your own responsibilities, adequate safety measures including but not limited to fail-safe design against the physical injury, damage to any property, which a failure or malfunction of our Products may cause. The following are examples of safety measures:
 - Installation of protection circuits or other protective devices to improve system safety
 - Installation of redundant circuits to reduce the impact of single or multiple circuit failure
- Our Products are designed and manufactured for use under standard conditions and not under any special or extraordinary environments or conditions, as exemplified below. Accordingly, ROHM shall not be in any way responsible or liable for any damages, expenses or losses arising from the use of any ROHM's Products under any special or extraordinary environments or conditions. If you intend to use our Products under any special or extraordinary environments or conditions (as exemplified below), your independent verification and confirmation of product performance, reliability, etc. prior to use, must be necessary:
 - Use of our Products in any types of liquid, including water, oils, chemicals, and organic solvents
 - Use of our Products outdoors or in places where the Products are exposed to direct sunlight or dust
 - Use of our Products in places where the Products are exposed to sea wind or corrosive gases, including Cl₂, H₂S, NH₃, SO₂, and NO₂
 - Use of our Products in places where the Products are exposed to static electricity or electromagnetic waves
 - Use of our Products in proximity to heat-producing components, plastic cords, or other flammable items
 - Sealing or coating our Products with resin or other coating materials
 - Use of our Products without cleaning residue of flux (even if you use no-clean type fluxes, cleaning residue of flux is recommended); or Washing our Products by using water or water-soluble cleaning agents for cleaning residue after soldering
 - Use of the Products in places subject to dew condensation
- The Products are not subject to radiation-proof design.
- Please verify and confirm characteristics of the final or mounted products in using the Products.
- In particular, if a transient load (a large amount of load applied in a short period of time, such as pulse. is applied, confirmation of performance characteristics after on-board mounting is strongly recommended. Avoid applying power exceeding normal rated power; exceeding the power rating under steady-state loading condition may negatively affect product performance and reliability.
- De-rate Power Dissipation (Pd) depending on Ambient temperature (Ta). When used in sealed area, confirm the actual ambient temperature.
- Confirm that operation temperature is within the specified range described in the product specification.
- ROHM shall not be in any way responsible or liable for failure induced under deviant condition from what is defined in this document.

Precaution for Mounting / Circuit board design

- When a highly active halogenous (chlorine, bromine, etc.) flux is used, the residue of flux may negatively affect product performance and reliability.
- In principle, the reflow soldering method must be used; if flow soldering method is preferred, please consult with the ROHM representative in advance.

For details, please refer to ROHM Mounting specification

Precautions Regarding Application Examples and External Circuits

1. If change is made to the constant of an external circuit, please allow a sufficient margin considering variations of the characteristics of the Products and external components, including transient characteristics, as well as static characteristics.
2. You agree that application notes, reference designs, and associated data and information contained in this document are presented only as guidance for Products use. Therefore, in case you use such information, you are solely responsible for it and you must exercise your own independent verification and judgment in the use of such information contained in this document. ROHM shall not be in any way responsible or liable for any damages, expenses or losses incurred by you or third parties arising from the use of such information.

Precaution for Electrostatic

This Product is electrostatic sensitive product, which may be damaged due to electrostatic discharge. Please take proper caution in your manufacturing process and storage so that voltage exceeding the Products maximum rating will not be applied to Products. Please take special care under dry condition (e.g. Grounding of human body / equipment / solder iron, isolation from charged objects, setting of ionizer, friction prevention and temperature / humidity control).

Precaution for Storage / Transportation

1. Product performance and soldered connections may deteriorate if the Products are stored in the places where:
 - [a] the Products are exposed to sea winds or corrosive gases, including Cl₂, H₂S, NH₃, SO₂, and NO₂
 - [b] the temperature or humidity exceeds those recommended by ROHM
 - [c] the Products are exposed to direct sunshine or condensation
 - [d] the Products are exposed to high Electrostatic
2. Even under ROHM recommended storage condition, solderability of products out of recommended storage time period may be degraded. It is strongly recommended to confirm solderability before using Products of which storage time is exceeding the recommended storage time period.
3. Store / transport cartons in the correct direction, which is indicated on a carton with a symbol. Otherwise bent leads may occur due to excessive stress applied when dropping of a carton.
4. Use Products within the specified time after opening a humidity barrier bag. Baking is required before using Products of which storage time is exceeding the recommended storage time period.

Precaution for Product Label

QR code printed on ROHM Products label is for ROHM's internal use only.

Precaution for Disposition

When disposing Products please dispose them properly using an authorized industry waste company.

Precaution for Foreign Exchange and Foreign Trade act

Since our Products might fall under controlled goods prescribed by the applicable foreign exchange and foreign trade act, please consult with ROHM representative in case of export.

Precaution Regarding Intellectual Property Rights

1. All information and data including but not limited to application example contained in this document is for reference only. ROHM does not warrant that foregoing information or data will not infringe any intellectual property rights or any other rights of any third party regarding such information or data. ROHM shall not be in any way responsible or liable for infringement of any intellectual property rights or other damages arising from use of such information or data.:
2. No license, expressly or implied, is granted hereby under any intellectual property rights or other rights of ROHM or any third parties with respect to the information contained in this document.

Other Precaution



1. This document may not be reprinted or reproduced, in whole or in part, without prior written consent of ROHM.
2. The Products may not be disassembled, converted, modified, reproduced or otherwise changed without prior written consent of ROHM.
3. In no event shall you use in any way whatsoever the Products and the related technical information contained in the Products or this document for any military purposes, including but not limited to, the development of mass-destruction weapons.
4. The proper names of companies or products described in this document are trademarks or registered trademarks of ROHM, its affiliated companies or third parties.

General Precaution

1. Before you use our Products, you are requested to carefully read this document and fully understand its contents. ROHM shall not be in any way responsible or liable for failure, malfunction or accident arising from the use of any ROHM's Products against warning, caution or note contained in this document.
2. All information contained in this document is current as of the issuing date and subject to change without any prior notice. Before purchasing or using ROHM's Products, please confirm the latest information with a ROHM sales representative.
3. The information contained in this document is provided on an "as is" basis and ROHM does not warrant that all information contained in this document is accurate and/or error-free. ROHM shall not be in any way responsible or liable for any damages, expenses or losses incurred by you or third parties resulting from inaccuracy or errors of or concerning such information.

Looking for pricing, stock, or lifecycle information?

Click below to explore more details on WIN SOURCE:

-  [View BD9757MWV-E2 on WIN SOURCE](#)
-  [Rohm Semiconductor](#) Information

Optimize Your Supply Chain with WIN SOURCE Solutions

-  Global Sourcing Solution
-  Obsolete Management
-  Cost Control Management
-  Shortage Management
-  Alternative Solution
-  Excess Inventory Management